

# APPENDIX E

## Model Equestrian Center – City of Rolling Hills Estates

October 6, 2010

File No. 5382-01

City of Rolling Hills Estates  
4050 Palos Verdes Drive North  
Rolling Hills Estates, California 90274

Attention: Mr. Andy Clark, Community Services Director

Subject: **GEOTECHNICAL INVESTIGATION REPORT - PRELIMINARY FINDINGS**  
Peter Weber Equestrian Center  
Proposed Equine Stable Facility  
26401 Crenshaw Blvd.  
Rolling Hills Estates, California

Dear Mr. Clark:

In accordance with your request, American Geotechnical has completed a geotechnical investigation of the subject property located at 26401 Crenshaw Blvd. in the City of Rolling Hills Estates, California as indicated on Plate 1. The purpose of this investigation was to evaluate the site geotechnical conditions and to make grading and foundation recommendations for the proposed equine facility. Our findings, conclusions, and preliminary recommendations for earthwork and foundations are presented below.

It is noted that the final building design has not been selected at this time and that upon selection of the structure design, a final geotechnical engineering report will be issued with building-specific foundation recommendations.

## 1.0 **SCOPE OF WORK**

The scope of the work performed during this investigation included the following:

- Review of previous geotechnical engineering reports prepared for the project site;
- Excavation and logging, using visual and tactile methods, of six small-diameter borings;
- Collection of undisturbed and bulk samples of representative materials encountered in all excavations;

- Laboratory testing of the selected soil samples;
- Engineering analyses of field and laboratory data, and
- Preparation of this report summarizing our field investigation, laboratory testing, findings, conclusions, and recommendations.

## **2.0 SITE DESCRIPTION AND HISTORY**

The Peter Weber Equestrian Center (Project Site) is located at 26401 Crenshaw Blvd. north of the intersection of Crenshaw Blvd. with Palos Verdes Drive North in the City of Rolling Hills Estates, Los Angeles County, California (see Plate 2). The existing equestrian facility includes various pipe corral stables (with plywood awnings and various wood and plastic supply storage bins), pipe corral arenas, and perimeter/interior access roads. The plywood awnings and storage supply structures have exceeded their useful life and are currently maintained by stable renters on an as-needed basis.

The project site is situated along the western margin of the Palos Verdes Landfill, a former Class I landfill which operated between 1952 and 1980 and is owned by the Los Angeles County Sanitation District (LACSD). The project site is located immediately adjacent to, and locally encroaches within, the southern Class I portion of the landfill (identified as Main Site) and is reportedly underlain by fill soils, the landfill cap (clayey soils), and cover materials (clay) mixed with refuse/waste materials.

Portions of the equestrian facility have experienced repeated ground settlement as a result of the continuous settlement of the underlying landfill necessitating frequent placement of additional surface fill soils to maintain a relatively level ground surface for the horses and personnel.

## **3.0 PREVIOUS INVESTIGATION REPORT REVIEW**

LACSD, in conjunction with the State of California Department of Toxic Substance Control (DTSC) has performed various characterization investigations of the landfill to identify the locations of trash/refuse, locations of the perimeter of the landfill trash/refuse and cap, and gas/vapor emission hazards. Previous site characterization investigation soil testing performed by Converse Consultants has identified landfill debris/trash adjacent to and underlying the project site. Analytical

testing confirmed the presence of organochlorine pesticides including 4,4-DDD (0.61-5.6 mg/kg), 4,4-DDE (0.017-0.72 mg/kg), and 4,4-DDT (0.34-23 mg/kg) in the underlying soils. Previous site characterization investigation soil testing and gas vapor monitoring performed by others for the Los Angeles County Sanitation District have detected the presence of low levels of Volatile Organic Compounds (VOC's) including methane (20,000 ug/kg) and methylene chloride (0.5 ug/kg), PCE(1.3 ug/kg), TCE (0.2 ug/kg), TCA (4.1 ug/kg) in soil gas vapors emitted from the underlying soils.

Previous geotechnical investigation borings were advanced at the project site by Converse Consultants in 2007 (see Plate 3) in an attempt to define lateral extents of the landfill trash/refuse with respect to the "then proposed" equestrian facilities. These borings reportedly encountered varying thicknesses of fill soils overlying landfill cap materials and trash/refuse. Groundwater was encountered at that time at a depth of 70.5 feet below the existing ground surface. The fill soils and landfill cap soils reportedly ranged from 5 to 20 feet in depth with refuse/trash underlying the fill at some locations and ranging in depths from 10 to 60 feet below the landfill cap soils.

#### **4.0 CURRENT PROJECT DEVELOPMENT PLANS**

The current phase of redevelopment of the project site includes the westerly pipe corral area as indicated on Plate 3 (area formerly identified as Phase II) and a location west of the pipe corrals where temporary pipe corrals would be located during construction of the proposed stable facilities. Plate 3 also illustrates the previously defined limits of the landfill cap and trash/refuse from Converse Consultants and other site characterization investigations. No formal facility design for the proposed stable facilities is available at this time; however, it is anticipated that the proposed structure will be founded on shallow spread footings, grade beams, or pile foundation systems in native soil and not to encroach into areas of known landfill refuse/debris.

#### **5.0 SUBSURFACE INVESTIGATION**

Our subsurface investigation included drilling six (6) small-diameter borings at the project site. Two of the borings (AGB-1 and AGB-2) were advanced north-west of the existing stable complex within the County of Los Angeles maintained property where temporary corrals would be constructed while the proposed new equine facility is constructed. The remaining four borings (AGB-3 thru

AGB-6) were advanced around the perimeter of the pipe corrals to further define the underlying soil conditions. The approximate locations of the borings are shown in Plate 4.

The field investigation was performed under a Work Plan prepared by American Geotechnical dated June 7, 2010, which was approved by the State of California Department of Toxic Substance Control (DTSC) and the Los Angeles County Sanitation District (LACSD). A Health and Safety Plan was prepared by American Geotechnical dated July 15, 2010, to address physical and environmental hazards associated with the investigation and to establish site-specific safety protocols. The borings were drilled by a State of California Licensed C-57 Drilling Contractor with Hazmat Certification under the supervision of a State of California Certified Engineering Geologist and Hydrogeologist. All field personnel had previously received appropriate OSHA training (minimum 40-hour HAZWOPER training with annual renewal certification) prior to entry to the project site. As part of the Health and Safety Plan, a tailgate safety meeting was performed at the start of the work day with all American Geotechnical and drilling personnel assigned to the project. A copy of the tailgate safety meeting sign-in sheet is provided as Appendix A.

Vapor monitoring was performed throughout the drilling activities in accordance with the Health and Safety Plan utilizing a Photovac MicroFID (flame ionizing detector) and a MiniRAE 2000 PID (photo ionization detector). Monitoring was performed in three (3) distinct zones: within 3 inches above the soil surface after soil was generated from the borings; in the "breathing zone" for the drilling helper (identified as up to 3 feet above the ground surface) to assure a safe working environment; and in the "breathing zone" for the drilling operator and geologist/engineer personnel (identified as 4 to 7 feet above the ground surface) to assure a safe working environment.

The highest concentration of Total Volatile Organic Compounds (VOC's) detected was 102 parts per million (ppm) in Boring AGB-5 at a depth of 15 feet below the ground surface. The VOC readings for the remainder of the borings were below 100 ppm. The highest Methane concentration detected was also in Boring AGSB-5 at a depth of 15 to 20 feet at a concentration of 38 ppm. Methane concentrations did not exceed 15 ppm on the other borings.

All work performed for this investigation was accomplished under Level "D" Health and Safety and Personnel Protection protocols as specified in the Health and Safety Plan.

Borings AGB-1 and AGB-2 were drilled in southwestern limits of the former landfill to depths of approximately 11.5 feet and 16.5 feet, respectively, below ground surface. The materials encountered within these borings included approximately 1 to 5 feet of fill soils over colluvium and bedrock. The fill consisted of gray-brown, moist and loose silty sand materials. Colluvial soils were encountered in Boring AGB-2 underlying the surface fill soils to an approximate depth of 10 feet. Bedrock of the Monterey Formation was encountered below the fill and colluvial soils consisting of tan-gray to orange-brown, moist, dense, silty sand (siltstone).

Boring AGB-3 was drilled in the northwest portion of the existing pipe corrals to a depth of approximately 21.5 feet below ground surface. The materials encountered within our boring included approximately 4-foot thick fill soils over Monterey Formation bedrock. The fill consisted of light-gray, moist and medium dense sand overlying light gray, moist, stiff clayey sand. Bedrock of the Monterey Formation was encountered at approximately 4 feet below the ground surface consisting of olive-gray to orange-brown, moist, stiff clay interbedded with thin lenses of silty sand.

Boring AGB-4 was drilled in the northeast portion of the existing pipe corrals to a depth of approximately 20.5 feet below ground surface. The materials encountered within our boring included approximately 2.5-foot thick fill over Monterey Formation bedrock. The fill consisted of olive-gray, moist and firm silty clay. Bedrock of the Monterey Formation was encountered at approximately 2.5 feet below the ground surface consisting of orange-brown, moist and stiff silty clay.

Boring AGB-5 was drilled in the northeast portion of the facility between two existing pipe corrals to a depth of approximately 20 feet below ground surface. The materials encountered within our boring included approximately 2-foot thick fill over 3 feet of colluvium over Monterey Formation bedrock. The fill consisted of blue-gray, moist and firm clay. The colluvium consisted of blue-gray, moist and silty clay. Bedrock of the Monterey Formation was encountered at approximately 5 feet below the ground surface consisting of orange-brown to olive-brown, moist and stiff silty clay and clay.

Boring AGB-6 was drilled in the southeast portion of the facility between two existing pipe corrals to a depth of approximately 20.5 feet below ground surface. The materials encountered within our

boring included approximately 8-foot thick fill over Monterey Formation bedrock. The fill consisted of blue-gray to olive-grown, moist and firm clay. Bedrock of the Monterey Formation was encountered at approximately 8 feet below the ground surface consisting of orange-brown, moist, stiff, silty clay and silt (claystone and siltstone).

The borings were logged by our field personnel using both visual and tactile methods. Detailed logs of the borings are presented in Appendix B. Representative samples of the subsurface materials were collected and forwarded to the laboratory for the purpose of estimating material properties for use in subsequent engineering evaluations.

The soil borings were backfilled with neat bentonite grout slurry after completion of drilling and monitored for settlement. Any boring which experienced immediate settlement was “topped off” with additional bentonite grout slurry. The borings were observed 24-hours following completion and “topped off” (8 to 15 inches) with cement to the ground surface.

## **6.0 CONTAINED SOIL/RINSATE TESTING AND DISPOSAL**

All soil cuttings derived from the borings and water generated during the steam cleaning processes were contained in 55-gallon drums that were labeled and temporarily stored on the project site for off-site characterization and disposal.

Soil samples obtained from the retained/drummed soil cuttings were collected, sealed, and preserved on-site and submitted for analytical testing under chain-of-custody documentation. The analytical testing included: Total Petroleum Hydrocarbons as gasoline by Modified EPA Method 8015G, Total Petroleum Hydrocarbons as diesel by Modified EPA Method 8015D, Total Recoverable Petroleum Hydrocarbons as oil and grease by EPA Method 418.1, Volatile Organic Compounds by EPA Method 8260, Semi-Volatile Organic Compounds by EPA Method 8270, Organochlorine Pesticides by EPA Method 8081, and State of California CAM Metals.

Rinsate water samples were obtained from the drum, sealed, preserved, and submitted for analytical testing under chain-of-custody documentation. The analytical testing included: Total Petroleum Hydrocarbons as gasoline by Modified EPA Method 8015G, Total Petroleum Hydrocarbons as diesel by Modified EPA Method 8015D, Total Recoverable Petroleum

Hydrocarbons as oil and grease by EPA Method 418.1, Volatile Organic Compounds by EPA Method 8260, and Semi-Volatile Organic Compounds by EPA Method 625/8250.

The results of the analytical testing of the soil/rinsate are included in Appendix C.

Subsequent to receipt of the analytical testing, Patriot Environmental Services was retained to transport and dispose of the contained soil/rinsate to an approved and appropriate landfill disposal facility. The containers were picked up from the project site on September 16, 2010, for direct transportation and disposal under hazardous materials manifest documentation protocols and released by the County of Los Angeles Department of Sanitation personnel. Disposal documentation will be provided under separate cover when received.

## **7.0 GEOTECHNICAL LABORATORY TESTING**

Laboratory testing was performed on samples collected during our field exploration. Samples were tested for the purpose of estimating material properties for use in the subsequent engineering evaluation. Tests included in-situ moisture/density, maximum density and optimum moisture content, expansion index, collapse/swell potential, gradation, direct shear, and corrosion potential. A summary of our laboratory test results is presented in Appendix D.

As shown in Appendix D, the laboratory test results indicate that the site soil possesses medium expansive characteristics with the expansion index (EI) varying from 57 to 74.

## **8.0 GEOTECHNICAL CONSIDERATIONS**

The main concerns for the proposed project include continued settlement of the adjacent/underlying landfill materials, vapor migration from the decaying landfill debris, and expansive soil influences. The soil borings advanced for this investigation further extended the "non-landfill" area of the existing equestrian complex and provides for better planning for the proposed structures/facilities.

Significant future settlement due to continuing degradation of waste is expected within the landfill area. As such, no critical improvements should be planned within landfill boundaries. The defined approximate limits of acceptable subsurface soil conditions (non-landfill) are depicted on Plate 5.



The State of California Department of Toxic Substance Control has put forth a requirement that any enclosed or partially enclosed structure proposed for the project should have a methane vapor barrier and collection system installed beneath it to avoid the potential for concentrations of flammable or toxic vapors beneath the structure. Since the actual facility design has not been selected at this time (open corrals, partial barn structure, overhead canopy, etc.), this action item is not specifically addressed herein other than for reference for future considerations.

The on-site, near-surface soil was also found to possess medium-high expansive characteristics based upon expansion index testing (expansion index as high as 74). Soils with a significant clay fraction tend to possess expansive characteristics. Expansive soil heaves when water is introduced and shrinks as it dries. Expansive soil tends to be active near the ground surface. The actual depth varies with specific material type and environmental differences. To reduce the effect of expansive soil on surface structures, foundation systems are usually deepened. Slabs and foundations are usually reinforced to increase their resistance to differential movement. It is usually suggested in planning yard improvements and a landscape theme that maintaining uniform moisture conditions, as much as practical, around isolated individual structures is desirable. Preferably, soil should be kept on the moist side without allowing ponding. Since water tends to migrate under slab areas, saturation of the slab subgrade for conventional construction is usually recommended prior to placement of slab concrete. This process, presaturation, activates the soil expansion prior to slab placement and thereby limits both the tendency towards edge lift and long-term heave. Deepened exterior footings for a conventional foundation system also serve to limit the degree to which drying can occur and thereby limit edge drop as well. Placing trees within about 10 feet of structures is not desirable because they tend to extract water and contribute to edge drop. Large trees should be kept at an even greater distance unless special precautions are taken.

## **9.0 SEISMICITY**

A risk common to all areas of Southern California is the potential for damage resulting from seismic events (earthquakes). The site is located within a seismically active area, as is all of Southern California. Although we are not aware of any active or potentially active faults on or within the immediate vicinity of the site, earthquakes generated on large regional faults such as the Newport-Inglewood, Elsinore, San Andreas, etc., could affect the site.

According to State of California, Special Publication 42, Fault Rupture Hazard Zones in California, the subject site is not located within a zone affected by fault rupture. According to State of California Seismic Hazard Maps, Torrance Quadrangle, the subject site is not located within a zone that is prone to earthquake-induced liquefaction.

The closest active fault is the northwest-trending Palos Verdes Fault located approximately 2.4 miles from the subject site. For the Palos Verdes Fault, an estimated peak earthquake magnitude ( $M_w$ ) of 7.1, and a peak acceleration of 0.61g, are anticipated at the site.

## **10.0 CONCLUSIONS AND PRELIMINARY RECOMMENDATIONS**

### **10.1 Basis**

Conclusions and recommendations contained in this report are based upon information provided, information gathered, engineering and geologic evaluations, experience, and professional judgment. Recommendations contained herein should be considered minimums consistent with industry practice. More rigorous criteria could be adopted if lower risk of future problems is desired. Where alternatives are presented, regardless of what approach is taken, some risk will remain, as is always the case. Usually the lowest risk is associated with the greatest cost.

### **10.2 Site Suitability**

Based on our investigation, an approximate boundary between acceptable soil conditions and landfill areas has been identified and presented in Plate 5. It is feasible that the proposed development can occur in the acceptable soil area identified in this plate. It is our opinion that the site identified as acceptable soil area can be improved without hazard of landslide, slippage, or damaging settlement, and improvements can occur without similar adverse impact on adjoining properties. Realizing this expectation will require adherence to good construction practice, agency and code requirements, the recommendations in this report, and possible addendum recommendations made after plan review and at the time of construction.

### 10.3 Seismic Design Parameters

The closest known active fault to the site is the northwest-trending Palos Verdes Fault located approximately 2.4 miles from the subject site. The following seismic design parameters, based on the 2007 Edition of the California Building Code (CBC), Chapter 16, Section 1613, are provided below for consideration in the design.

- |    |                                      |   |       |
|----|--------------------------------------|---|-------|
| 1. | Site Class                           | : | C     |
|    |                                      |   |       |
| 2. | Site Coefficients                    |   |       |
|    | • $F_a$                              | : | 1.0   |
|    | • $F_v$                              | : | 1.3   |
|    |                                      |   |       |
| 3. | Mapped spectral accelerations        |   |       |
|    | • $S_s$ (for short periods)          | : | 2.022 |
|    | • $S_1$ (for 1-second period)        | : | 0.841 |
|    |                                      |   |       |
| 4. | Site adjusted spectral accelerations |   |       |
|    | • $S_{MS}$ (for short periods)       | : | 2.022 |
|    | • $S_{M1}$ (for 1-second period)     | : | 1.093 |
|    |                                      |   |       |
| 5. | Design spectral accelerations        |   |       |
|    | • $S_{DS}$ (for short periods)       | : | 1.348 |
|    | • $S_{D1}$ (for 1-second period)     | : | 0.729 |

The potential for liquefaction at the site during earthquake shaking is considered to be unlikely due to shallow bedrock conditions.

It should be realized that the purpose of the seismic design, utilizing the above parameters, is to safeguard against major structural failures and loss of life but not to prevent damage altogether. Even if the structural engineer provides designs in accordance with the applicable codes for seismic design,

the possibility of damage cannot be ruled out if moderate to strong shaking occurs as a result of a large earthquake. This is the case for essentially all structures in Southern California.

#### **10.4 Earthwork**

The proposed construction may require grading at the site. Prior to the start of grading operations, utility lines within the project area, if any, should be located and marked in the field so they can be rerouted or protected during site development. All tree roots should be properly removed at the time of grading. Construction may also require demolition of the existing improvements. Within the demolition area, all foundation elements of existing structures should be entirely removed and disposed of off-site. All debris and perishable material should be removed from the site. The area of site preparation should extend at least 5 feet beyond the proposed improvements.

It is our recommendation that all of the existing fill soil be excavated to the contact with the firm underlying bedrock and placed back as properly compacted fill. Based on the information obtained from our investigation, the depth of over-excavation may range from 5 to 10 feet depending on the location of the proposed improvements. A more specific recommendation regarding the depth of removal can be provided when specific development plans are available. The actual removal depth may also be locally increased based on the observation of soil conditions encountered during grading. In any event, the maximum differential fill thickness should not exceed more than 5 feet across any proposed building.

When excavations deeper than 5 feet are made, temporary construction slopes should be no steeper than 1.5:1 (horizontal to vertical). Sheeting and bracing should be provided by the contractor, as necessary, to protect workers in the excavation. Where excavations undermine existing improvements such as the existing walls, etc., temporary structural support should be provided to reduce the risk of damage resulting from undercutting. Permanent cut and fill slopes should not be constructed steeper than 2:1 and should be considered subject to review by the geotechnical consultant at the time of grading. These slopes should possess sufficient compacted fines to limit erosion risk. If upon construction, relatively clean, cohesionless sands are encountered, reconstruction by blending in fines to compacted fill and/or flattening of slopes will be advised.

Where fill is to be placed, the upper 6 to 8 inches of the surface exposed by the excavation should be scarified, moisture-conditioned to 2 to 3 percent over optimum moisture content, and compacted to 90 percent relative compaction.<sup>1</sup> If localized areas of relatively loose soil prevent proper compaction, over-excavation, and recompaction will be necessary

The on-site soil is generally suitable for use as compacted fill. As an alternative to native soil, imported granular soil can be considered as a backfill material. If used, the imported material should meet the following criteria.

1. No particles larger than 6 inches in largest dimension.
2. Free of perishable material.
3. Plasticity Index of 20 or less and Liquid Limit of 40 or less.
4. Expansion Index of 20 or less.

All grading should be conducted in accordance with the applicable codes, agency requirements, the aforementioned recommendations, and the grading guidelines which accompany this report as Appendix E.

### **10.5 Foundation Design**

Expansive soil influence is an important geotechnical consideration at the site for the foundation design and, as such should be given careful consideration by the project architect and structural engineer. As design aids, this report includes some minimum criteria. The structural engineer is responsible to design an adequate foundation system considering these minimum criteria and all soil-structure interaction effects. If either the architect or the structural engineer requires more information or assistance, they should contact American Geotechnical's project engineer.

In addition to the expansive soil influences, continuing settlement of adjacent landfill areas may also affect the site. We recommend that all critical improvements should have a minimum setback of 10 feet from the landfill boundary as identified in Plate 5.

---

<sup>1</sup> Relative compaction refers to the ratio of the in-place dry density of soil to the maximum dry density of the same material as obtained by the "modified proctor" (ASTM D1557) test procedure.

It is our recommendation that the foundation system for the proposed improvement derive support in bedrock. A combination of a shallow and deep foundation system can be utilized depending on the depth to bedrock at the specific location where the improvements will occur. Geotechnical design criteria for both deep and shallow foundations are given below.

### **Deep Foundation**

A deep foundation system consisting of a pile-grade beam system could be used to support the proposed structures. The recommended minimum pile diameter is 2 feet. Piles embedded at least 5 feet into firm bedrock may be designed using a maximum allowable end bearing capacity of 5,000 psf. Prior to placement of concrete, care must be taken to keep the excavation bottom neat, level and square, and free of any loose or sloughed material.

As an alternative to end bearing piles, friction piles could be used. A vertical pile capacity for an isolated 24-inch diameter friction pile is presented in Plate 6. Capacities for other pile sizes can be determined in direct proportion to pile diameters. In determining the pile capacity, end bearing has been ignored. Additionally, the allowable capacities include a factor-of-safety of 2.0. The allowable vertical compression capacities may be increased by 33 percent to accommodate temporary loads such as from wind or seismic forces. For sustained tension loads, 50 percent of the compression capacities should be used. Piles should be spaced at least 3 feet in diameter apart.

For friction piles, care must be taken to ream the pile excavation within the bearing zone in order to clean the excavation side walls of any smear resulting from the drilling operation. The bottom of the excavation should be kept reasonably free of loose or sloughed material.

In the lateral design, the passive resistance in firm bedrock is 300 pcf. The tributary area for pressure distribution resistance in front of each cast-in-place pile is equal to two diameters of piles.

### **Shallow Foundation**

A shallow strip foundation system for the building could also be utilized where applicable. If used, the shallow foundation system should be designed for the following criteria.

Minimum depth (feet) (measured from lowest adjacent grade)	3
Minimum embedment (feet) within the firm bedrock	1
Minimum width (feet)	1.5
Allowable bearing pressure (pounds per square foot – psf)	
a. Sustained loads	2,500
b. Total loads (including wind or seismic)	3,333
Resistance to lateral loads	
a. Passive soil pressure within firm bedrock	300
(equivalent fluid pressure, pounds per cubic foot)	
b. Coefficient of sliding friction	0.40

The allowable bearing pressures are for dead plus long-term live loads and include a factor-of-safety of at least 3.0.

The coefficient of friction should be applied to dead load forces only.

Passive earth pressure may be used for the sides of footings cast against bedrock. The upper 2 feet of passive resistance should be neglected unless the soil is confined by pavement or slab.

Foundations constructed in accordance with the above recommendations are expected to settle less than 1 inch total and 1/2-inch differential.

### **10.6 Slab-on-Grade**

The interior slab-on-grade, if proposed, can be constructed on newly compacted fill. The slab-on-grade should be a minimum of 6 inches thick and reinforced with No. 4 bars at 12 inches on center, both ways. The slab should be underlain by 3 inches of sand over a 15-mil Stego wrap membrane. The sand should contain sufficient fines to allow light compaction (e.g., drum roller) to an unyielding condition. Preferably, a minor cement fraction (e.g., 1 to 3 percent) could be blended with the sand to

achieve a smooth, unyielding surface. The Stego membrane splices should be staggered between layers. The membrane should be sealed at all splices, around plumbing, and at the perimeter of slab areas. Every effort should be made to provide a continuous barrier, and care should be taken not to puncture the membrane. Below the vapor barrier and on top of the subgrade, an approximately 4-inch thick layer of free-draining crushed rock base (e.g., 3/4-inch rock) should be provided. The crushed rock should have no more than 10 percent passing the 3/4-inch sieve, nor more than 3 percent passing the No. 200 sieve. To protect the vapor barrier from punctures during placement, it is recommended that a light, non-woven geofabric (e.g., Mirafi 140N) be placed between the crushed rock and vapor barrier. We also recommend that the upper 2 feet of subgrade be presaturated.

### **10.7 Exterior Flatwork**

The exterior slabs should be a minimum of 6 inches thick and reinforced with No. 4 bars at 12 inches on center, both ways. Additionally, the slab should be underlain by a minimum 4-inch thick free draining, graded crushed rock base. For larger slab areas, minimum 24-inch deep and 18-inch wide cut-off walls should be provided along the edges of the slabs. The concrete flatwork can be broken up with architectural separations and/or minor landscape strips to minimize the impact from expansive soil. Movement of slabs adjacent to structures can be mitigated by doweling slabs to perimeter footings. Doweling should consist of No. 4 bars bent around exterior footing reinforcement. Dowels should be extended at least 2 feet into planned exterior slabs. Doweling should be spaced consistent with the reinforcement schedule for the slab. With doweling, 3/8-inch minimum thickness expansion joint material should be provided. Where expansion joint material is provided, it should be held down about 3/8-inch below the surface. The expansion joints should be finished with a color matched, flowing, flexible sealer (e.g., pool deck compound) sanded to add mortar-like texture. As an option to doweling, an architectural separation could be provided between the main structures and abutting appurtenant improvements.

Cut-off walls are not necessarily required for walkways and other minor flatwork provided thickened edges are constructed, some additional flexibility is provided for (e.g., more expansion joints), and the risk associated with expansive soil movement is recognized. A minimum 10-inch thickened edge is recommended in such cases. Where flatwork is relatively near trees, cut-off walls or specially designed root barriers are strongly encouraged. For large trees within about 10 feet of



flatwork or main structures, cut-off walls and footings should be deepened to about 4 feet below the lowest adjacent grade. Alternatively, a specially designed root barrier(s) could be provided.

### **10.8 Concrete**

The soil in the project area has low levels of sulfates and is not significantly corrosive to concrete. However, it is our general recommendation that low permeability concrete be utilized at the site. As such, the water-to-cement ratio to be used in the concrete mix design should be limited to 0.5 (0.45 preferred). Additionally, use of minimum Type II (Type V preferred) cement is also recommended. Limited use (subject to approval of mix designs) of a water-reducing agent may be included to increase workability. The concrete should be properly cured to minimize risk of shrinkage cracking. The code dictates at least seven days of moist curing. Two to three weeks is preferred to minimize cracking. One-inch hard rock mixes should be provided. Pea gravel mixes are specifically not recommended but could be utilized for relatively non-critical improvements (e.g., flatwork) and other improvements, provided the mix designs consider limiting shrinkage. The contractor/other designers should take care in all aspects of designing mixes, detailing, placing, finishing, and curing concrete. The mix designers and contractor are advised to consider all available steps to reduce cracking. The use of shrinkage compensating cement or fiber reinforcing should be considered. Alternatively, the concrete mix can also incorporate W.R. Grace/Eclipse shrinkage reducing admixture dosed for maximum benefit. Mix designs proposed by the contractor should be considered subject to review by the project engineer.

### **10.9 Drainage**

The project civil engineer is the party responsible for site drainage; however, general drainage guidelines are provided below.

Drainage should be directed away from structures via non-erodible conduits to suitable disposal areas. Five percent drainage is recommended directly away from structures. At least 2 percent minimum is recommended for drainage over soil areas. Four to five percent minimum is advised for drainage away from structures and for planter and groundcover areas. In pipes or paved swales, 1 percent should be adopted as the minimum unless otherwise recommended by the project civil engineer. For yard drains, a 4-inch minimum pipe diameter is recommended because experience has

shown that 3-inch pipes tend to clog easier. All enclosed planters should be provided with a suitably located drain or drains and/or flooding protection in the form of weep holes or similar. Preferably (i.e., not a requirement), structures should have roof gutters and downspouts tied directly to the yard drainage system.

#### **10.10 Environmental Issues**

The recommendations above are conventional geotechnical recommendations. Given the proximity of the site to the former landfill and the pressures of various VOC's and methane, as mentioned earlier, design of all improvements will need to incorporate appropriate environmental considerations (e.g., methane barriers and collection systems).

#### **10.11 Plan Review**

When detailed grading and structural plans are developed, they should be forwarded to this office for review and comment. You may wish for this office to be directly involved with the project architect and engineer through the project planning process. If, in the future, additional improvements are proposed, plans for such improvements should be forwarded to this office for review and comment.

#### **10.12 Field Construction Review**

During construction, a number of reviews by this office are recommended to verify site geotechnical conditions and conformance with the intentions of the recommendations for construction. Although not all possible geotechnical observation and testing services are required by the City, the more site reviews requested, the lower the risk of future problems. The following site reviews are advised, some of which will probably be required by the City:

Preconstruction meeting	Advised
Grading	Required
Foundation excavation review	Required
Reinforcement placement for all foundations	Advised
Slab subgrade presaturation	Required
Waterproofing	Required
Slab subgrade preparation including rock placement	Advised

Slab steel placement, primary structures	Required
Slab steel placement, appurtenant structures	Advised
Drain and rock placement behind retaining walls	Required
Backfill compaction behind retaining walls	Required
Compaction of utility trench backfill	Required

Unless otherwise agreed to in writing, all supplemental consulting services will be provided on an as-needed, time-and-expense fee schedule basis.

### **10.13 Project Safety**

The contractor is the party responsible for providing a safe site. This consultant will not direct the contractor's operations and cannot be responsible for the safety of personnel other than his own representatives on site. The contractor should notify the owner if he is aware of and/or anticipates unsafe conditions. If the geotechnical consultant at the time of construction considers conditions unsafe, the contractor as well as the owner's representative will be notified. Within this report, the terminology safe or safely may have been utilized. The intent of such use is to imply low risk. Some risk will remain, however, as is always the case.

### **11.0 REMARKS**

Only a portion of subsurface conditions have been reviewed and evaluated. Conclusions, recommendations, and other information contained in this report are based upon the assumption that subsurface conditions do not vary appreciably between and adjacent to observation points. Although no significant variation is anticipated, it must be recognized that variations can occur.

This report has been prepared for the sole use and benefit of our client. The intent of the report is to advise our client on geotechnical matters involving the proposed improvements. It should be understood that the geotechnical consulting provided and the contents of this report are not perfect. Any errors or omissions noted by any party reviewing this report and/or any other geotechnical aspect of the project should be reported to this office in a timely fashion. The client is the only party intended by this office to directly receive the advice. Subsequent use of this report can only be authorized by

File No. 5382-01  
October 6, 2010  
Page 19

the client. Any transferring of information or other directed use by the client should be considered "advice by the client."

Geotechnical engineering is characterized by uncertainty. Geotechnical engineering is often described as an inexact science or art. Conclusions and recommendations presented herein are partly based upon the evaluations of technical information gathered, partly on experience, and partly on professional judgment. The conclusions and recommendations presented should be considered "advice." Other consultants could arrive at different conclusions and recommendations. Typically, "minimum" recommendations have been presented. Although some risk will always remain, lower risk of future problems would usually result if more restrictive criteria were adopted. Final decisions on matters presented are the responsibility of the client and/or the governing agencies. No warranties in any respect are made as to the performance of the project.

We hope that this is the information you require at this time. Please contact our office should you have any questions.

Respectfully submitted,

AMERICAN GEOTECHNICAL, INC.

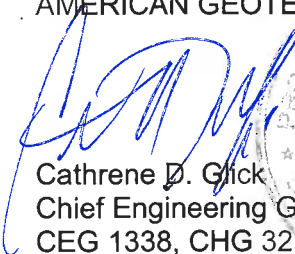
  
Cathrene D. Glick  
Chief Engineering Geologist / Hydrogeologist  
CEG 1338, CHG 32

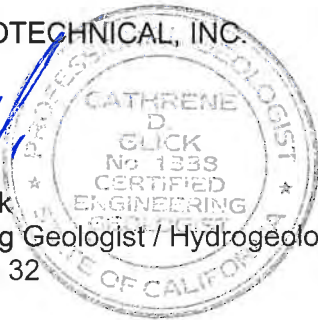

  
Arumugam Alvappillai, P.E.  
Principal Engineer  
G.E. 2504



CG/AA:dd

Enclosures: Plates 1 - 6  
Appendix A - Tailgate Safety Meeting Sign-In Sheet  
Appendix B - Boring Logs  
Appendix C - Analytical Testing Data  
Appendix D - Summary of Laboratory Data  
Appendix E - Geotechnical Guidelines for Grading Projects

Distribution: 2 – Addressee (Regular Mail and Email: [andic@ci.rolling-hills-estates.ca.us](mailto:andic@ci.rolling-hills-estates.ca.us))

**REFERENCES**

Work Plan for Geotechnical Investigation, Proposed Equine Stable Facility at the Peter Weber Equestrian Center, 26401 Crenshaw Blvd., Rolling Hills Estates, CA, prepared by American Geotechnical, Inc., dated June 7, 2010.

Health and Safety Plan for Geotechnical Investigation, Proposed Equine Stable Facility at the Peter Weber Equestrian Center, 26401 Crenshaw Blvd., Rolling Hills Estates, CA, prepared by American Geotechnical, Inc., dated July 15, 2010.

Geotechnical Investigation Report, Proposed Rolling Hills Estates Municipal Stables, 26041 Crenshaw Blvd., Rolling Hills Estates, CA, prepared by Converse Consultants, dated January 8, 2008.

State of California Department of Toxic Substance Control Letter, Change of Project Manager for the Palos Verdes Landfill Site, Rolling Hills Estates, CA 90274, dated January 11, 2010.

State of California Department of Toxic Substance Control Fact Sheet #13, November 2009, Five-Year Review Completed.

State of California Department of Toxic Substance Control Fact Sheet #9, March 2004, Five-Year Review of Landfill Remedial Systems.

State of California Department of Toxic Substance Control Fact Sheet, May 1990, Palos Verdes Landfill Remedial Investigation/Feasibility Study.

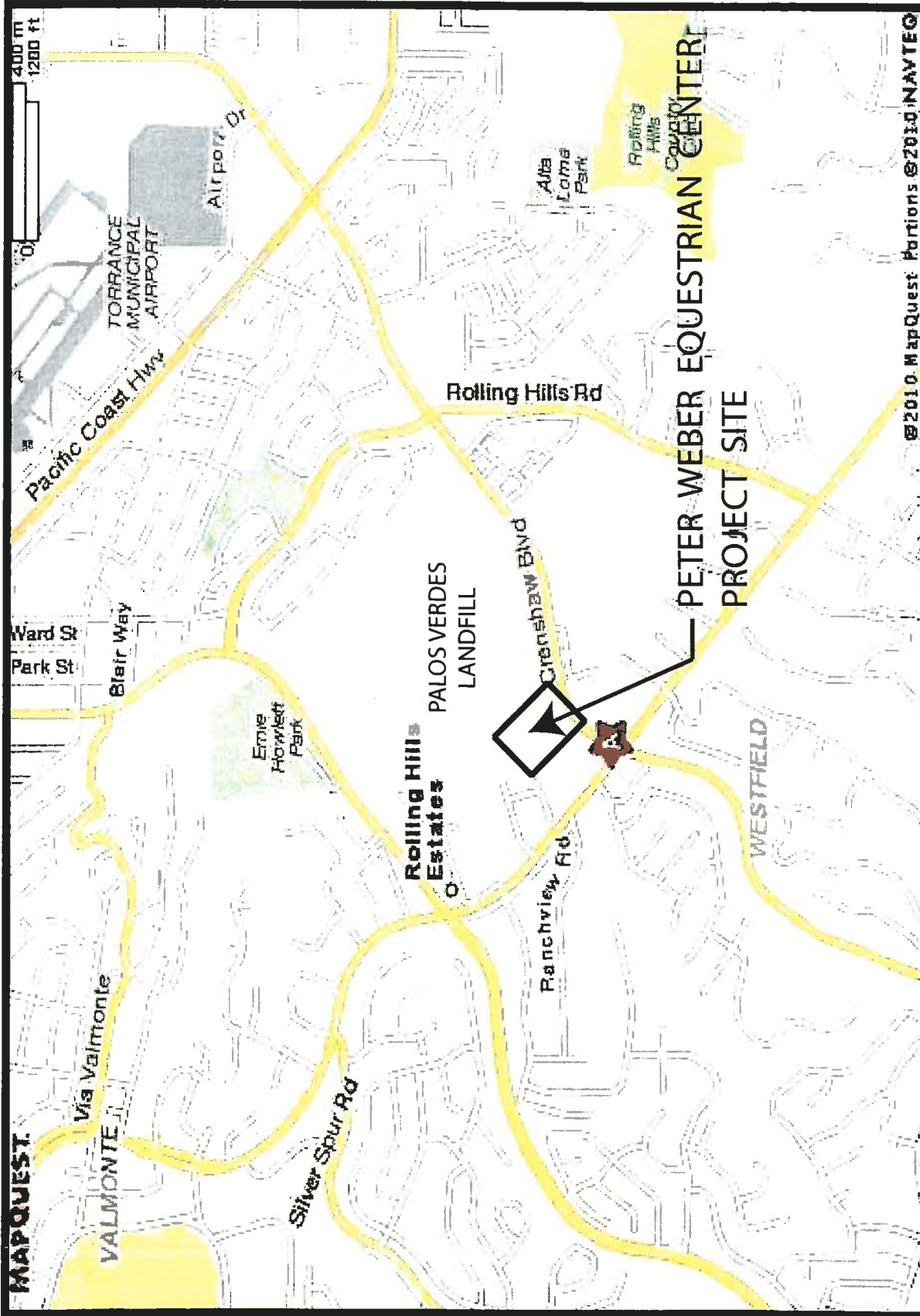

**PETER WEBER EQUESTRIAN CENTER**  
 26401 Crenshaw Boulevard  
 Rolling Hills Estates, California

**LOCATION MAP**  
 F.N. 5382.01  
 October 2010

Plate 1

**American Geotechnical, Inc.**  
 22725 Old Canal Road, Yorba Linda, CA 92887  
 Phone: (714) 685-3900, Fax: (714) 685-3909



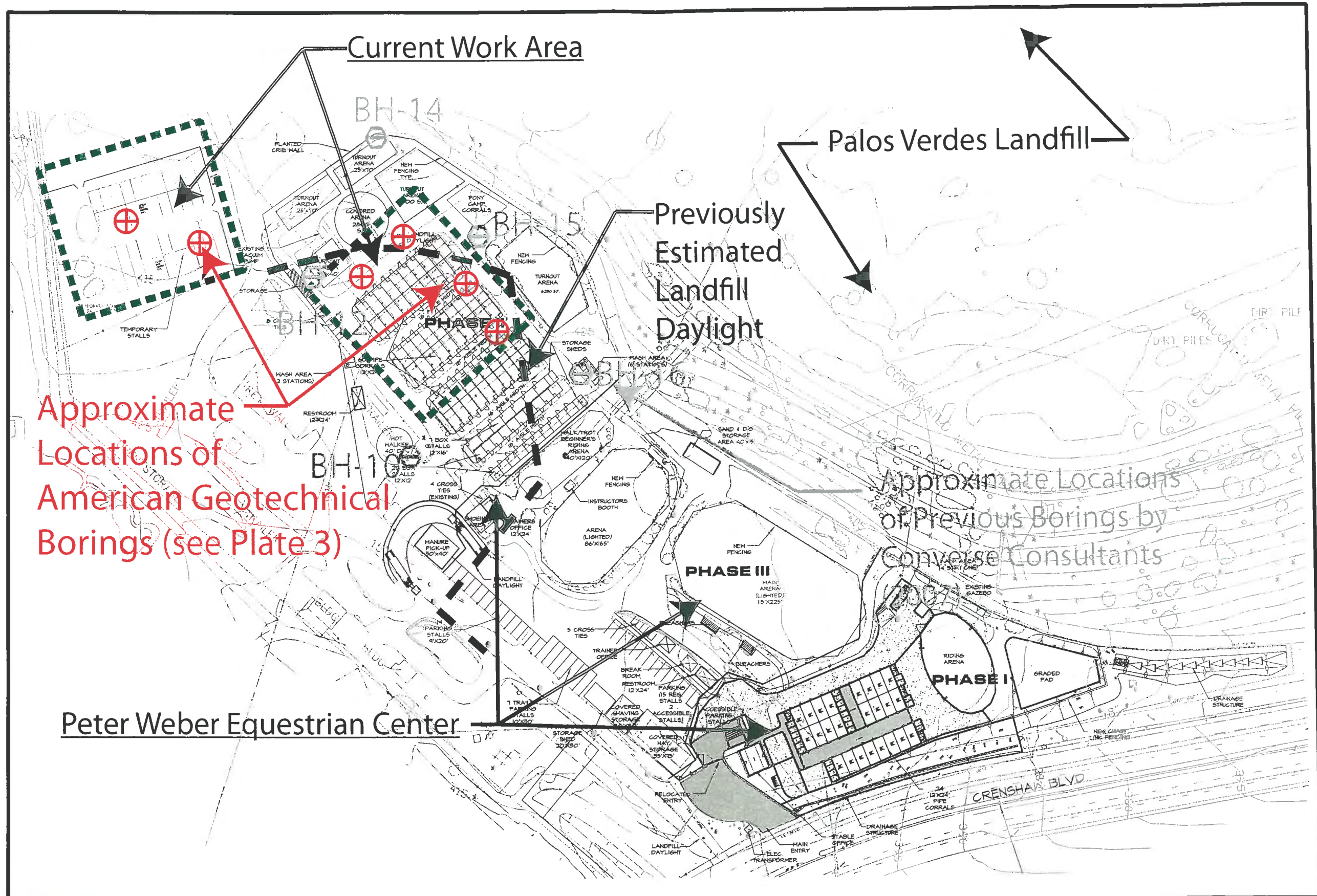

Approximate Locations of American Geotechnical Borings (see Plate 3)

Peter Weber Equestrian Center



American Geotechnical, Inc.

22725 Old Canal Road, Yorba Linda, CA 92887  
Phone: (714) 685-3900, Fax: (714) 685-3909

PETER WEBER EQUESTRIAN CENTER  
26401 Crenshaw Boulevard  
Rolling Hills Estates, California

PETER WEBER EQUESTRIAN CENTER  
SITE PLAN

F.N. 5382.01

October 2010

Plate 2

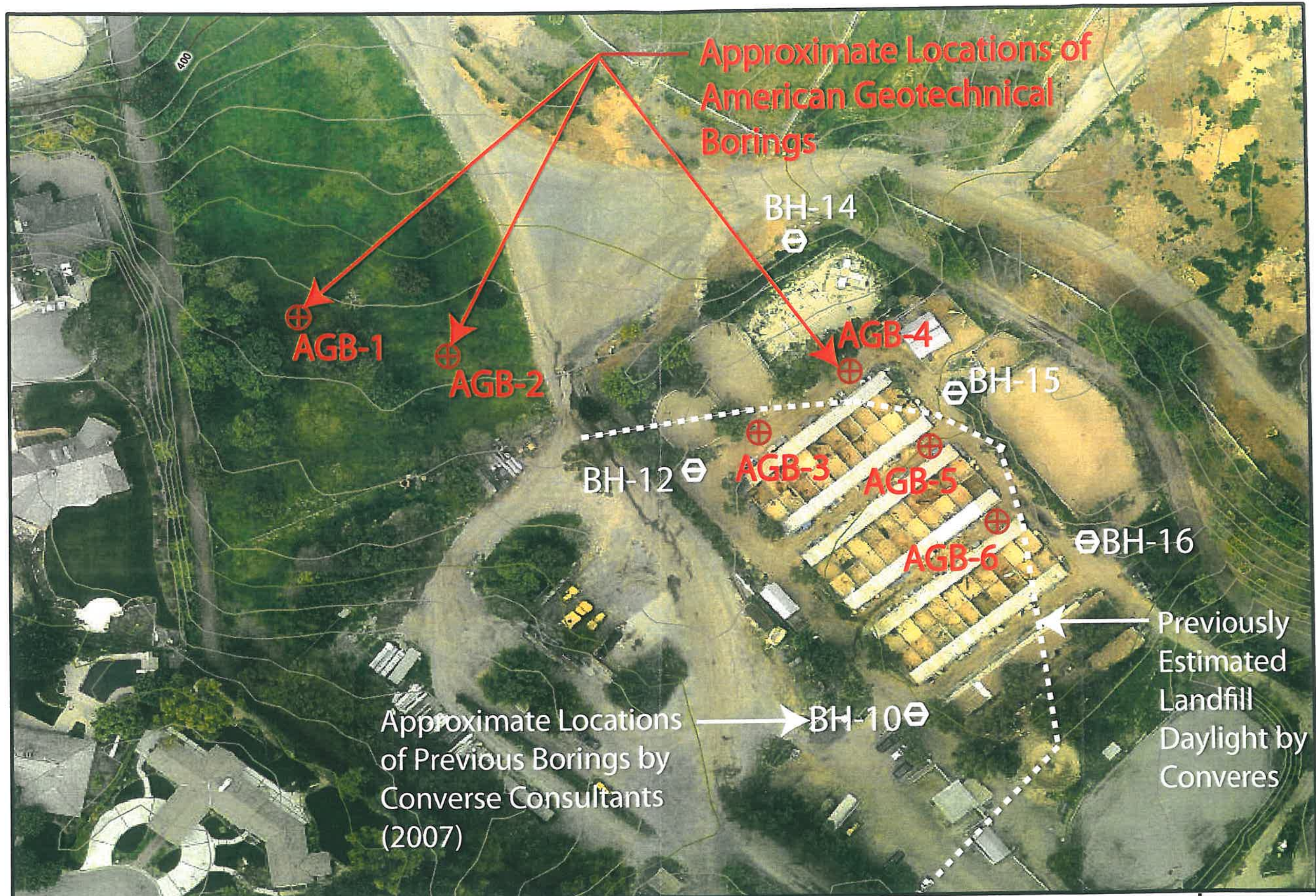

American Geotechnical, Inc.

22725 Old Canal Road, Yorba Linda, CA 92887  
 Phone: (714) 685-3900, Fax: (714) 685-3909

PETER WEBER EQUESTRIAN CENTER  
 26401 Crenshaw Boulevard  
 Rolling Hills Estates, California

BORING LOCATION PLAN

F.N. 5382.01

October 2010

Plate 3



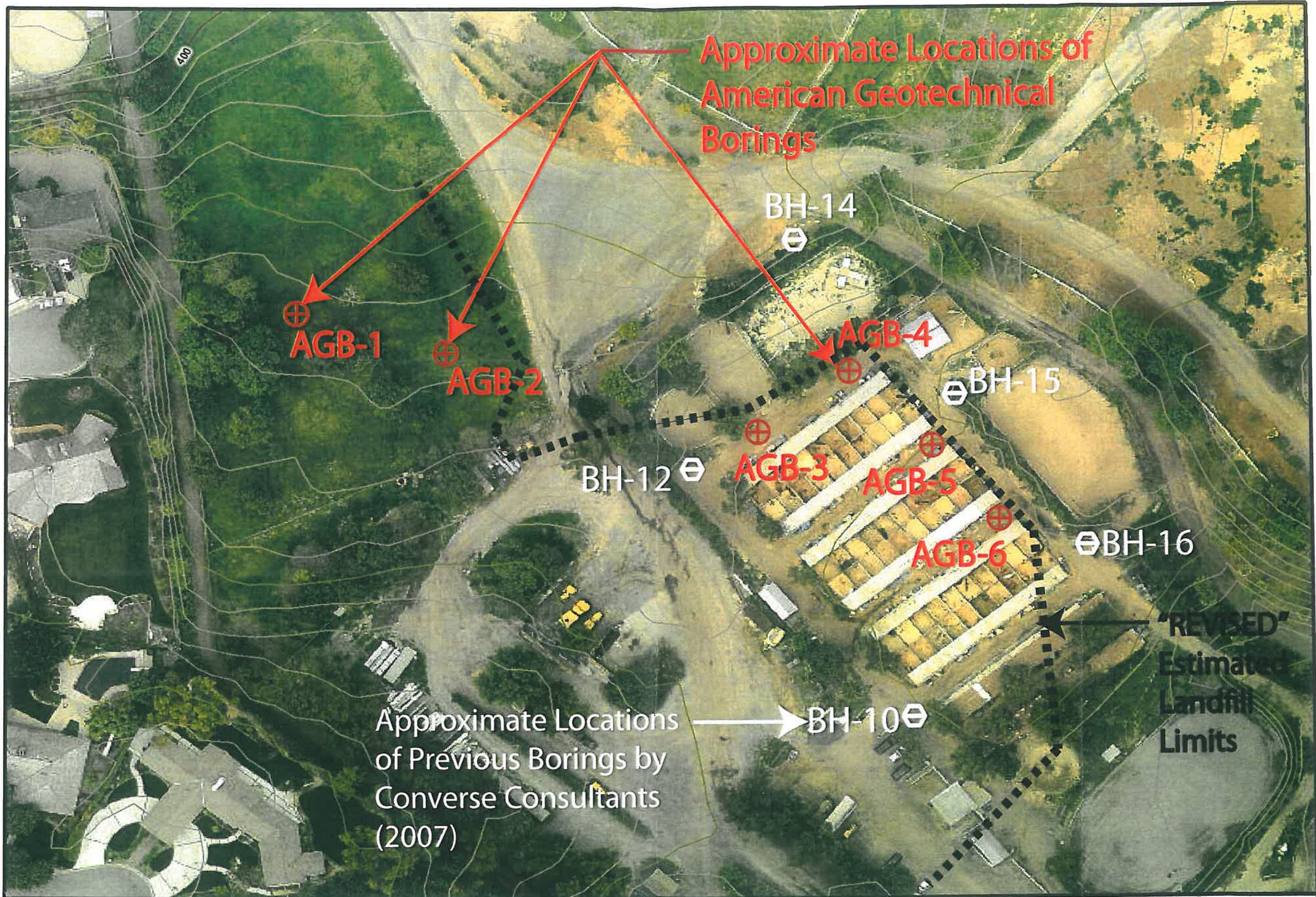

**American Geotechnical, Inc.**

22725 Old Canal Road, Yorba Linda, CA 92887  
 Phone: (714) 685-3900, Fax: (714) 685-3909

**PETER WEBER EQUESTRIAN CENTER**  
 26401 Crenshaw Boulevard  
 Rolling Hills Estates, California

**"REVISED" LANDFILL LIMIT PLAN**

F.N. 5382.01

October 2010

**Plate 4**

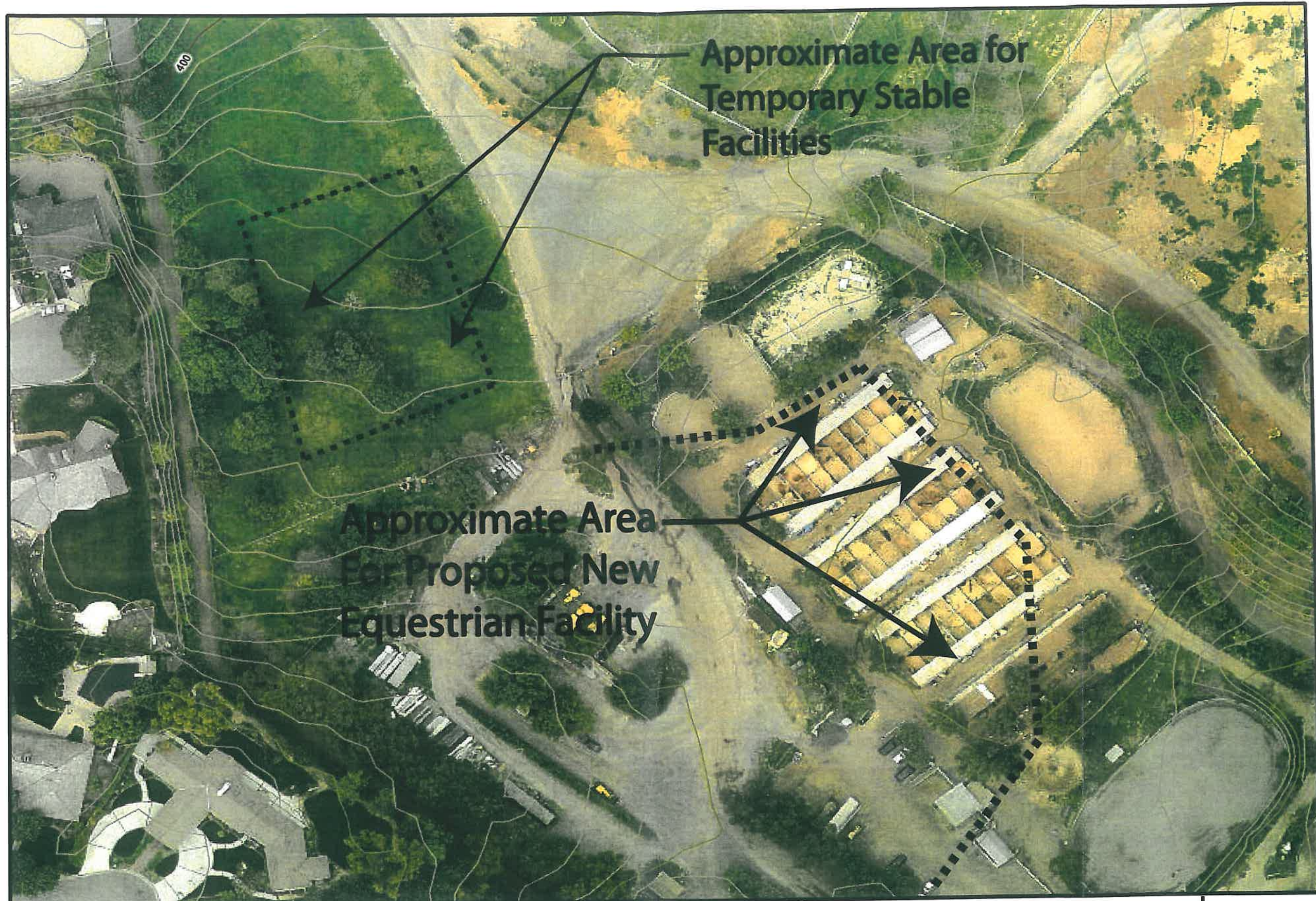

**American  
Geotechnical, Inc.**

22725 Old Canal Road, Yorba Linda, CA 92887  
Phone: (714) 685-3900, Fax: (714) 685-3909

**PETER WEBER EQUESTRIAN CENTER**  
26401 Crenshaw Boulevard  
Rolling Hills Estates, California

**BUILDING AREA LIMITS**

F.N. 5382.01

October 2010

**Plate 5**

### ALLOWABLE PILE CAPACITY (kips)

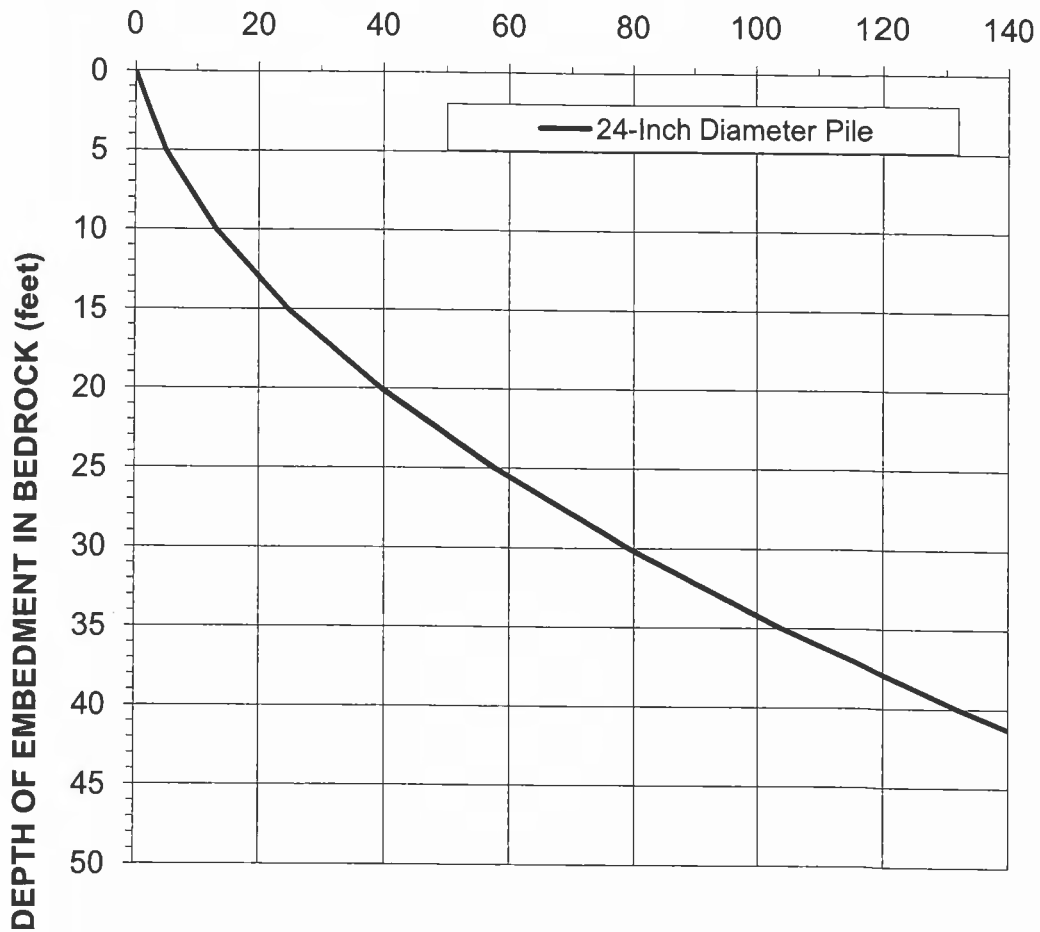

**NOTE:**

1. Capacities indicated are based on skin friction only. The structural capacity of the piles should be checked.
2. The indicated capacities are for sustained (dead plus live) vertical compression load, and include a safety factor of at least 2.0.
3. For temporary wind or seismic load, the above values may be increased by one-third.
4. For sustained tension loads, use 50 percent of compression capacities.
5. Capacities of other pile sized are in direct proportion to the pile perimeter.

File No. 5382-01  
October 6, 2010

**APPENDIX A**

**Tailgate Safety Meeting Sign-In Sheet**

July 15, 2010

File No. 05382-01

City of Rolling Hills Estates  
4050 Palos Verdes Drive North  
Rolling Hills Estates, California 90274  
Attention: Mr. Andy Clark, Community Services Director

Subject: **HEALTH AND SAFETY PLAN FOR GEOTECHNICAL INVESTIGATION  
PROPOSED EQUINE STABLE FACILITY AT THE  
PETER WEBER EQUESTRIAN CENTER,  
26401 CRENSHAW BOULEVARD  
ROLLING HILLS ESTATES, CA**

Dear Mr. Clark:

American Geotechnical, Inc. has prepared the attached Health and Safety Plan to support our previously submitted Work Plan to address the proposed geotechnical engineering and environmental field activities related to our geotechnical engineering assessment and foundation design investigation services for the subject Peter Weber Equestrian Center equine stable facility.

The attached Health and Safety Plan addresses the known site conditions and anticipated environmental hazards associated with performing the subsurface investigation at the subject site (which is situated along the western margin of the Palos Verdes Landfill), presents protocols for personnel protection during the drilling and soil sampling activities.

Copies of this Health and Safety Plan have been submitted directly to the following agency personnel for comment and concurrence:

Los Angeles County Sanitation District  
Palos Verdes Landfill  
Ms. Kristen Ruffell, Project Manager  
1955 Workman Mill Road  
Whittier, CA 90601

State of California  
Department of Toxic Substance Control  
Ms. Eileen Khachatourians, Project Manager  
5796 Corporate Avenue  
Cypress, CA 90630

We appreciate the opportunity to serve the City of Rolling Hills Estates with geotechnical engineering and environmental management services.

Respectfully submitted,

  
Cathlene Diane Glick, CEG, CHG  
Project Manager/Chief Geologist

**HEALTH AND SAFETY PLAN FOR  
GEOTECHNICAL INVESTIGATION  
PROPOSED EQUINE STABLE FACILITY AT THE  
PETER WEBER EQUESTRIAN CENTER  
26401 CRENSHAW BOULEVARD  
ROLLING HILLS ESTATES, CA**

This Health and Safety Plan (HSP) has been prepared for the American Geotechnical, Inc. and subcontractor personnel to accomplish the field investigation activities addressed in the Work Plan For Geotechnical Investigation, Proposed Equine Stable Facility At The Peter Weber Equestrian Center, 26401 Crenshaw Boulevard Rolling Hills Estates, CA prepared by American Geotechnical, Inc dated June 7, 2010, and is incorporated therein by reference.

This HSP has been prepared from the best available information concerning the site conditions at the tie. The health and safety specifications presented in this HSP are based on reasonable knowledge that chemicals such as methane, carbon dioxide, hydrogen sulfide, volatile organic compounds, and organochlorine pesticides are present in the soil and soil vapors at the project site.

### **1.0 KEY PERSONNEL**

American Geotechnical Project Manager/Engineering Geologist/SSO  
Ms. Cathrene Diane Glick  
Office Phone: 714-685-3900  
Mobile Contact: 714-363-1483

### **2.0 PROJECT SITE BACKGROUND**

The Peter Weber Equestrian Center (Project Site) is located at 26401 Crenshaw Boulevard north of the intersection of Crenshaw Boulevard with Palos Verdes Drive North in the City of Rolling Hills Estates, Los Angeles County, California (see Figure 1).

The Project Site is situated along the western margin of the Palos Verdes Landfill, a former Class I landfill which operated between 1952 and 1980 and is owned by the Los Angeles County Sanitation District (LACSD). The Project Site is located immediately adjacent to, and locally encroaches within, the southern Class I portion of the landfill (identified as Main Site) and is reportedly underlain by fill soils, the landfill cap (clayey soils) and cover materials (clay) mixed with refuse/waste materials.

LACSD, in conjunction with the State of California Department of Toxic Substance Control (DTSC) have performed various characterization investigations of the landfill to identify the locations of trash/refuse, locations of the perimeter of the landfill trash/refuse and cap, and gas/vapor emission hazards. Previous site characterization investigation soil testing performed by Converse Consultants have identified landfill debris/trash adjacent to, and underlying, the Project Site and analytical testing confirmed the

presence of organochlorine pesticides including: 4,4-DDD (0.61-5.6 mg/kg), 4,4-DDE (0.017-0.72 mg/Kg), and 4,4-DDT (0.34-23 mg/Kg) in the underlying soils. Previous site characterization investigation soil testing and gas vapor monitoring performed by others for the Los Angeles County Sanitation District have detected the presence of low levels of Volatile Organic Compounds (VOC's) including: methane (20,000 ug/Kg) and methylene chloride (0.5 ug/Kg), PCE(1.3 ug/Kg), TCE (0.2 ug/Kg), TCA (4.1 ug/kg) in soil gas vapors emitted from the underlying soils.

Previous geotechnical investigation borings were advanced at the Project Site by Converse Consultants in 2007 (see Figure 3) in an attempt to define lateral extents of the landfill trash/refuse with respect to the "then proposed" equestrian facilities. These borings reportedly encountered varying thicknesses of fill soils overlying landfill cap materials and trash/refuse. Groundwater was encountered at that time at a depth of 70.5 feet below existing ground surface. The fill soils and landfill cap soils reportedly ranged from 5- to 20-feet in depth with refuse/trash underlying the fill at some locations and ranging in depths from 10- to 60-feet below the landfill cap soils.

### **3.0 CURRENT SCOPE OF WORK**

The current scope of work includes advancing up to six (6) shallow subsurface investigation borings within the western portion of the Project Site (identified as Project Work Area) to be advanced at the locations identified on Figures 2 and 3 as described in the referenced Work Plan and summarized below:

#### ***3.1 Subsurface Borings***

Two (2) of the borings will be advanced in the temporary corral area which is considered to be outside of the landfill boundary and is anticipated to be underlain by fill soils and native Alluvium and Monterey Formation sediments. Four (4) additional borings will be advanced around the existing pipe corrals to better define the limits of the native soil materials and fill materials to further reduce the potential for the equine facility expansion encroachment into the landfill cap and underlying landfill trash/refuse.

The borings would be drilled by a State of California Licensed C-57 Drilling Contractor with Hazmat Certification and would be logged under the supervision of a State of California Certified Engineering Geologist and Hydrogeologist. All field personnel will have received appropriate OSHA training (minimum 40-hour HAZWOPER training with annual renewal certification) prior to entry to the project site.

Prior to proceeding with the subsurface investigation, all drilling augers, cutting heads, and sample equipment will be steam cleaned to assure that there is not an introduction of off-site contamination to the underlying soils.

The proposed borings will be advanced utilizing a drill rig equipped with 8-inch diameter hollow-stem auger and will extend to a maximum depth of 25-feet below the existing ground surface. The borings would be visually logged and sampled at intervals of 2-1/2, 5, 10, 15, and 20-feet for soil characterization and geotechnical engineering properties. Any boring which encounters landfill cap/cover materials, particularly soils which include any trash/refuse will be terminated at that specific depth.

Soil borings which do not encounter any landfill trash/refuse will be backfilled with neat bentonite-cement grout slurry after completion of drilling. Soil borings which do encounter landfill trash debris will be backfilled with bentonite pellets to at least 2-feet above the landfill trash/debris interface (and hydrated) and the remainder of the boring will be backfilled with neat bentonite-cement grout slurry after completion of drilling. The bentonite-cement slurry will be monitored within 24-hours following completion and "topped off" with additional cement to the ground surface.

Following completion of the subsurface investigation, all drilling augers, cutting heads, and sample equipment will be steam cleaned to assure that contaminants, if any, are not transported off-site.

All soil cuttings derived from the borings will be contained in 55-gallon drums immediately upon emergence from the boring. All rinsate water generated during the steam cleaning processes would be drummed immediately following completion of the decontamination process. All drums will be labeled and temporarily stored in a secure location on the project site pending off-site waste characterization and subsequent transportation for disposal.

#### Task Analysis:

- ✓ Mobilization
- ✓ Traffic/Pedestrian/Animal Control
- ✓ Soil Boring
- ✓ Collection of Soil Samples
- ✓ Containment of Soil Cuttings
- ✓ Decontamination of Equipment
- ✓ Containment of Decontamination Rinsate and Sludge
- ✓ Secure Storage of Soil/Rinsate Containment Drums
- ✓ Demobilization

### **3.2 Hazard Analysis**

Hazards associated with performing the investigation work include:

#### Site Hazards

- ✓ Horses and Horse Handlers/Riders/Observers
- ✓ Equestrian Center Employees, Vehicles, Equipment
- ✓ Contact with horse manure and organic materials
- ✓ Slip, Trip, and Fall Situations
- ✓ Soil Contamination and Landfill Trash/Debris
- ✓ Soil Gas Vapors
- ✓ Inhalation and Contact with Organic Vapors



### Equipment Hazards

- ✓ Drilling and Mechanical Equipment
- ✓ Overhead Cables
- ✓ Flying Particulates
- ✓ Steam Cleaning Equipment
- ✓ Drum Handling Equipment
- ✓ Portland Cement Concrete and Bentonite Grout Mixing

### **3.3 Personal Protection Levels**

The scope of the Health and Safety Plan includes minimizing exposure to organic vapors and contaminated soil originating at the project site during the investigation activities, to assure that organic vapors are not detected beyond the project work area boundaries during the proposed investigation, and that a safe working environment is maintained.

This Health and Safety Plan has been prepared to describe the specific work activities, site work conditions, daily site activities and human/animal occupancy, contaminants of concerns, anticipated vapor or soil contaminant concentrations anticipated to be performed or encountered at the project site, and to document specific site safety issues (including first aid and local emergency contact and hospital information) and addressed at daily Site Safety Tailgate meetings.

All work for the current scope of work is anticipated to be performed under Level "D" Health and Safety and Personnel Protection protocols. The following constitute Level D equipment:

1. Hard Hat.
2. Coveralls/Standard Work Clothing
3. Goggles or Safety Glasses
4. Gloves, nitrile or equivalent.
5. Hearing Protection
6. Boots, steel toe and shank.

Soil vapor monitoring will occur during the subsurface investigation activities to maintain a safe working environment and to assist in delineating the top of the landfill (if encountered). Previous on-site investigations detected measurable volatile organic vapors once the clay cap was encountered and significant vapors were detected once landfill trash/debris was encountered.

If site conditions change and a higher degree of protection is required, the Site Safety Officer will suspend work and initiate Level "C" Health and Safety and Personnel Protection protocols. A change in the required level of personal protective equipment would constitute a change to the HSP and a supplemental Tailgate Safety Meeting would be held to address the new site conditions.

The following constitute Level C equipment; it may be used as appropriate:

1. Hard Hat.
2. Coveralls.
3. Goggles or Safety Glasses
4. Gloves, outer, chemical-resistant.
5. Gloves, inner, chemical-resistant. (optional, as applicable)
6. Hearing Protection
7. Boots (outer), chemical-resistant steel toe and shank.
8. Boot-covers, outer, chemical-resistant (disposable). (optional, as applicable)
9. Full-face or half-mask, air purifying respirators (NIOSH approved).
10. Hooded chemical-resistant clothing (overalls; two-piece chemical-splash suit; disposable chemical-resistant overalls, optional, as applicable).
11. Face shield. (optional, as applicable)

### **3.4 Exposure Monitoring**

American Geotechnical will implement the following on-site personal protection and monitoring program:

- Our personnel will be providing continuous Soil Vapor Monitoring with an Organic Vapor Analyzer (OVA) or an Organic Vapor Meter (OVM) at project site immediately adjacent to the auger and soil cuttings
- Monitoring is to be performed no greater than 3-inches above the soil surface at an interval not to exceed 3-minutes after soil is removed
- Monitoring is to be performed in the “breathing zone” for the drilling helper (identified as up to 3-feet above the ground surface) to assure a safe working environment
- Monitoring is to be performed in the “breathing zone” for the drilling operator and geologist/engineer personnel (identified as 4- to 7-feet above the ground surface) to assure a safe working environment
- All vapor readings will be documented with date, time, location, and OVA/OVM readings

#### Soil Vapor Monitoring Detectable Vapors > 50 ppm but < 500 ppm (Level “D” PPE)

- Continue with investigation and monitoring as outlined above

#### Soil Vapor Monitoring – Detectable Vapors > 500 ppm for > 1 Minute (Level “D” PPE)

- Should vapors be detected in either of the monitoring zones above 500 ppm for over 1-minute, work will be suspended to determine if the vapor concentrations

are “peaks” or “continuous” readings and to assess if the landfill cap has been breached and we have encountered landfill debris

- If it is determined that the vapor concentrations are “peaks” work will be allowed to progress under the same working and monitoring conditions

Soil Vapor Monitoring – Detectable Vapors > 500 ppm continuous readings (Level “D” PPE)

- Should vapors be detected in either of the monitoring zones above 500 ppm on a continuous basis, work will be suspended to determine if the vapor concentrations are “peaks” or “continuous” readings
- If it is determined that the vapor concentrations are “peaks” work will be allowed to progress under the same working and monitoring conditions
- If it is determined that the vapor concentrations are “continuous”, work at the ground surface will be suspended until vapor concentrations are verified to diminish below 500ppm
- Particular care and attention would be established during auger disconnection from the drill head and vapor monitoring would occur and work will be suspended until vapor concentrations are verified to diminish below 500 ppm

Soil Vapor Monitoring – Detectable Vapors > 1,000 ppm (Level “D” PPE)

- Should vapors be detected in either of the monitoring zones above 1,000 ppm on a continuous basis, work will be suspended to determine if the vapor concentrations are “peaks” or “continuous” readings
- If it is determined that the vapor concentrations are “peaks” work will be allowed to progress under the same working and monitoring conditions
- Particular care and attention would be established during auger disconnection from the drill head and vapor monitoring would occur and work will be suspended until vapor concentrations are verified to diminish below 500 ppm
- If it is determined that the vapor concentrations are continuously above 1,000 ppm, the boring would be terminated and backfilled in accordance with the Work Plan
- Subsequent investigation activities in the immediate vicinity of the high vapor concentrations would proceed, if required, under Level “C” Personal Protection Protocol
- Should an increase in personal protection level be implemented to accomplish additional soil borings, all personnel will be removed from the work area, appropriate personnel protection procedures implemented, and a new Tailgate Safety Meeting would be conducted to address the elevated environmental and personnel safety protocols

Soil Vapor Monitoring – Detectable Vapors > 1,000 ppm but < 5,000 (Level “C” PPE)

- Continue with investigation and monitoring at various work breathing zones as outlined above  
Work would be terminated at vapor concentrations exceeding 5,000ppm.

**3.4 Decontamination and Waste Containment Procedures**

Following completion of the subsurface investigation, all drilling augers, cutting heads, and sample equipment will be steam cleaned to assure that contaminants, if any, are not transported off-site. All rinsate water generated during the steam cleaning processes would be drummed immediately following completion of the decontamination process. All drums containing rinsate water will be labeled and temporarily stored in a secure location on the project site pending off-site waste characterization and subsequent transportation for disposal.

All soil cuttings derived from the borings will be contained in 55-gallon drums immediately upon emergence from the boring. All drums containing soil cuttings will be labeled and temporarily stored in a secure location on the project site pending off-site waste characterization and subsequent transportation for disposal.

All disposable personal protective materials (gloves, tyvek coveralls, boot coverings, respirator cartridges, etc.) utilized during the investigation activities will be placed in trash bags, sealed and disposed of in approved on-site waste containers for disposal.

**4.0 EMERGENCY PROCEEDURES AND HOSPITAL INFORMATION**

American Geotechnical will assure that there is fire suppression equipment (5 lb Class A/B/C fire extinguisher) immediately accessible to the work area and the location of the fire extinguisher and on-site fire suppression support equipment will be identified during the tailgate safety meeting.

Limited first aid equipment (disinfectant, band aids, gauze pads, tape, trauma pads, gauze wraps, instant ice packs, etc.) will be available at the site at the designated area identified during the tailgate safety meeting.

Should medical services exceeding the limited on-site first aid capability be required, all work would be suspended immediately, the site secured, and the injured person would be attended to as the primary objective.

Emergency Contact Phone Number:

911

Site Location: Peter Weber Equestrian Center

26401 Crenshaw Boulevard Rolling Hills Estates

Cross Street/Intersection – Palos Verdes Drive North

In the event that the injury is not life-threatening and the injured person can be safely transported by personal vehicle to a medical center, the closest emergency hospital facility is:

Torrance Memorial  
3330 Lomita Blvd.  
Torrance, CA 90505  
310-325-9110

A map depicting the project site location, the location of the hospital, and travel path details is included as Figure 4.

Work would proceed only once the injured individual was attended to on-site with available first aid or once the injured individual is securely in transport to the medical facility and that adequate personnel remain on-site to perform the subsequent investigation duties in a safe manner.

#### **5.0 RESPONSIBLE PERSONNEL CONTACT INFORMATION**

The following personnel have been assigned to the current project:

##### **City of Rolling Hills Estates**

Community Services Director  
Mr. Andy Clark  
Office Phone: 310-377-1577

##### **American Geotechnical**

Project Manager/Engineering Geologist  
Ms. Cathrene Diane Glick  
Office Phone: 714-685-3900  
Mobile Contact: 714-363-1483

Questions or comments regarding this Health and Safety Plan should be addressed to the American Geotechnical representative listed above.

Respectfully submitted,  
American Geotechnical, Inc.

- Figures:
1. Location Map
  2. Site Plan
  3. Boring Location Plan
  4. Hospital Location and Travel Path

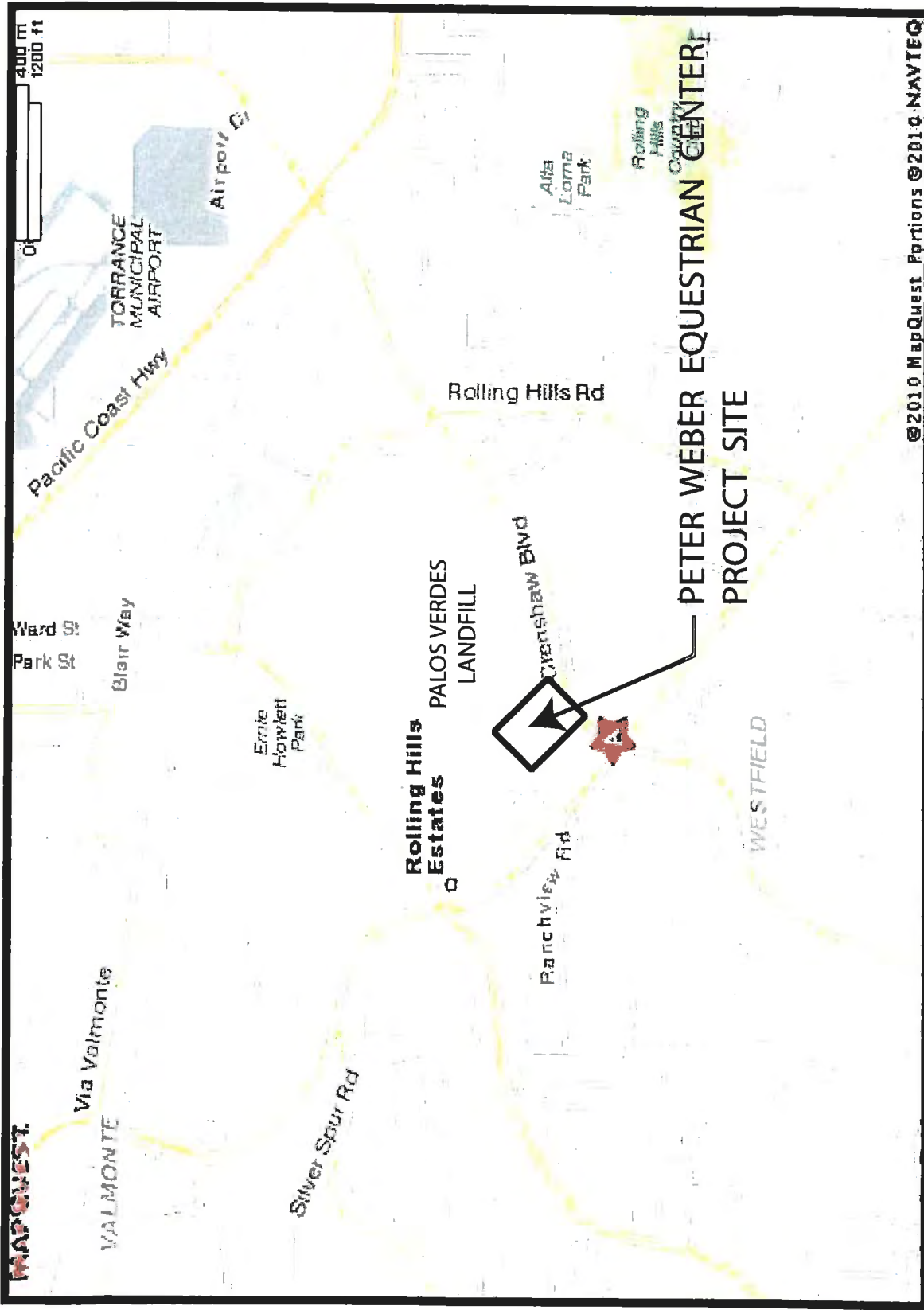

Figure 1

LOCATION MAP

PETER WEBER EQUESTRIAN CENTER  
 26401 Crenshaw Boulevard  
 Rolling Hills Estates, California

**American Geotechnical, Inc.**  
 22725 Old Canal Road, Yorba Linda, CA 92887  
 Phone: (714) 685-3900, Fax: (714) 685-3909

F.N. 5382.01

JUNE 2010

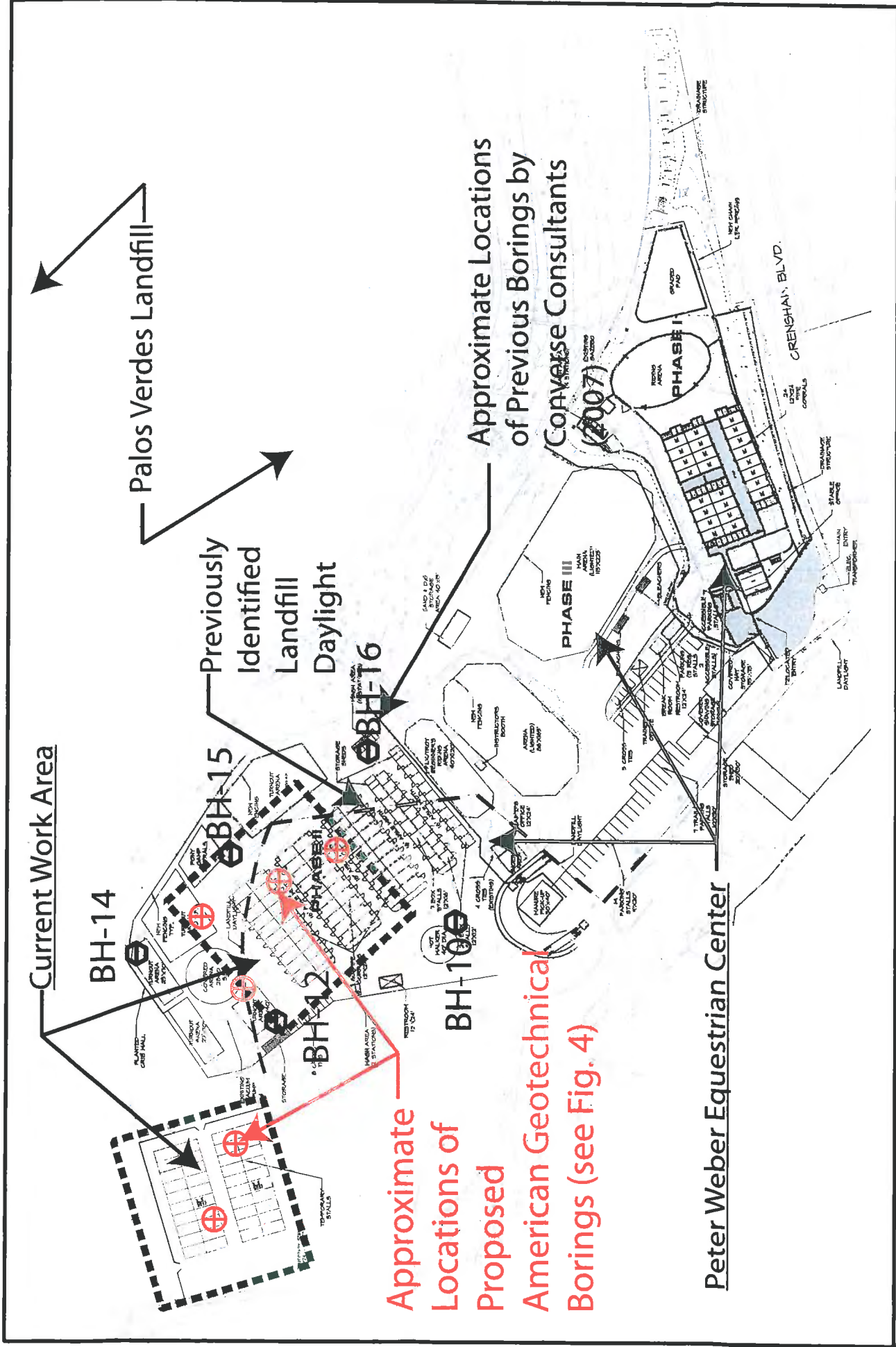

Current Work Area

Palos Verdes Landfill

Previously Identified Landfill Daylight

Approximate Locations of Previous Borings by Covarse Consultants (2007)

Approximate Locations of Proposed American Geotechnical Borings (see Fig. 4)

Peter Weber Equestrian Center

 <p>American Geotechnical, Inc.          22725 Old Canal Road, Yorba Linda, CA 92887          Phone: (714) 685-3900, Fax: (714) 685-3909</p>	<p>PETER WEBER EQUESTRIAN CENTER          26401 Crenshaw Boulevard          Rolling Hills Estates, California</p>	<p>PETER WEBER EQUESTRIAN CENTER          SITE PLAN</p>	<p>Figure 2</p>
	<p>F.N. 5382.01</p>	<p>JUNE 2010</p>	

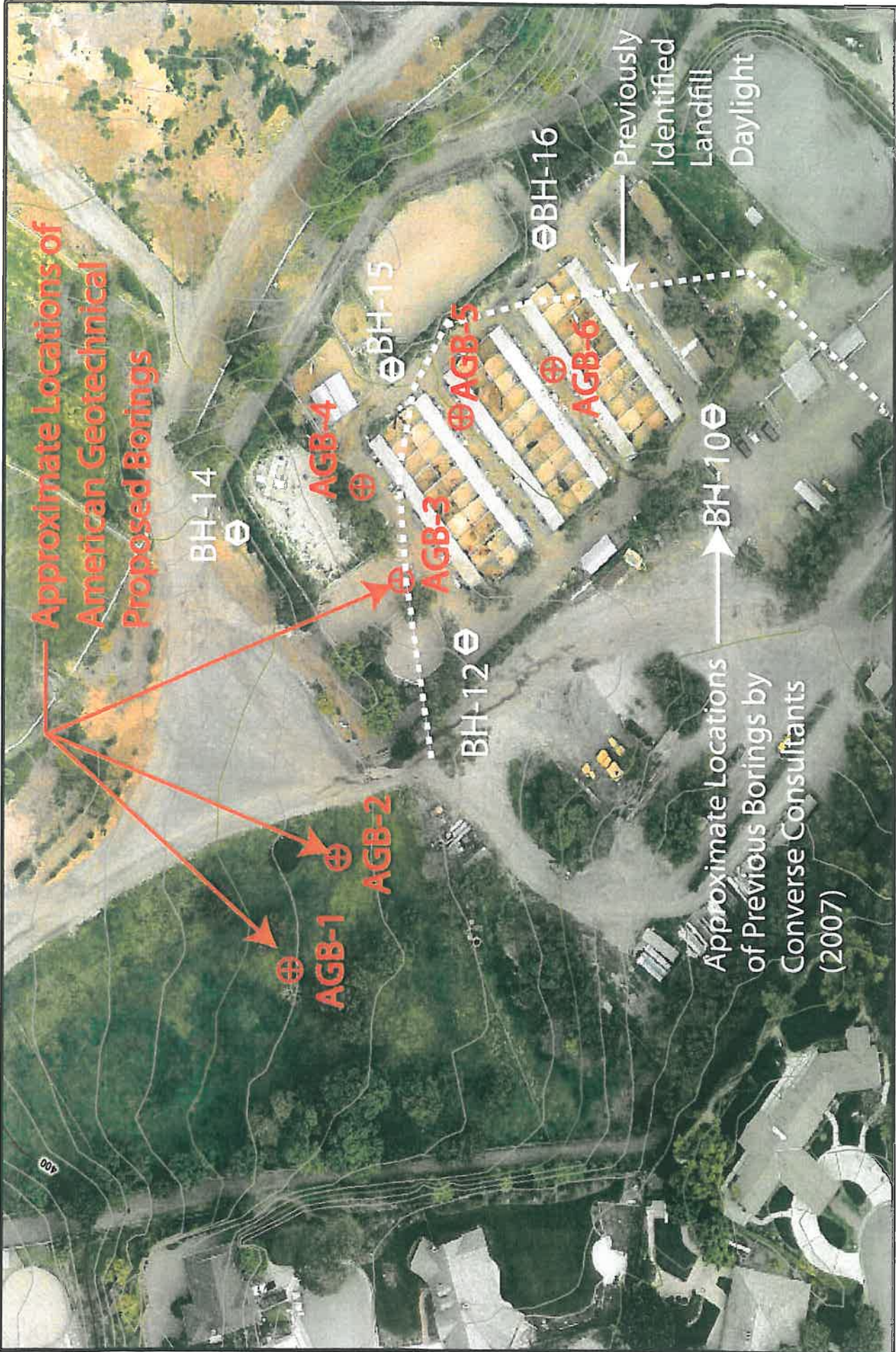

 <b>American Geotechnical, Inc.</b> 22725 Old Canal Road, Yorba Linda, CA 92887 Phone: (714) 685-3900, Fax: (714) 685-3909	<b>PETER WEBER EQUESTRIAN CENTER</b> 26401 Crenshaw Boulevard Rolling Hills Estates, California		<b>Figure 3</b>
	<b>BORING LOCATION PLAN</b> F.N. 5382.01		
			JUNE 2010



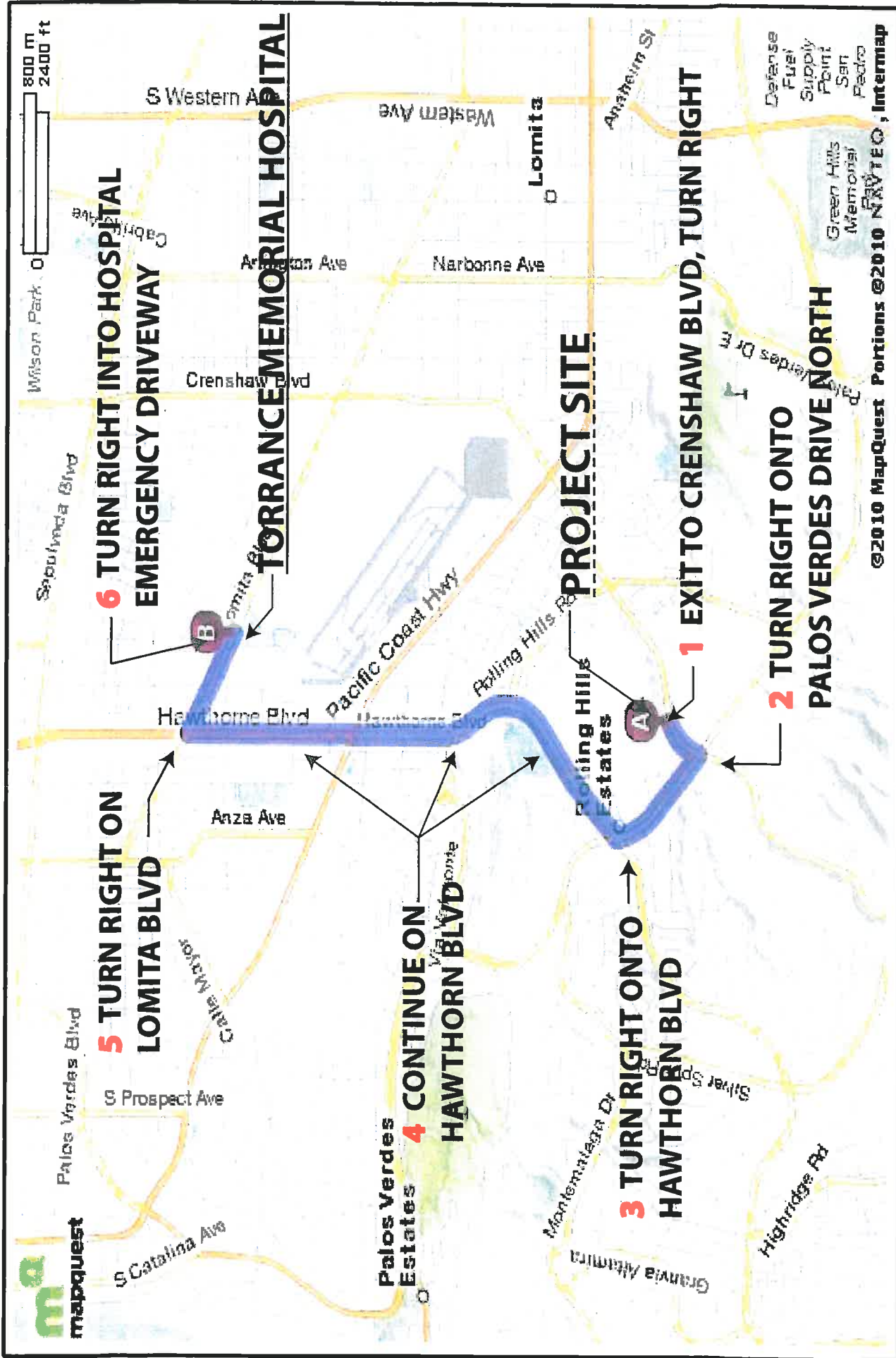

<b>American Geotechnical, Inc.</b> 22725 Old Canal Road, Yorba Linda, CA 92887 Phone: (714) 685-3900, Fax: (714) 685-3909	<b>PETER WEBER EQUESTRIAN CENTER</b> 26401 Crenshaw Boulevard Rolling Hills Estates, California		<b>HOSPITAL LOCATION PLAN</b>	<b>Figure 4</b>
	F.N. 5382.01		JUNE 2010	

**TAILGATE SAFETY MEETING SIGN IN SHEET**

Date: 8/3/10

Time: \_\_\_\_\_

Location: Peter Weber Equestrian Center, Rolling Hills Estates, California

Field Activities: Subsurface exploration to depths of 20-feet below ground surface

Site Hazards: Horses and Horse Handlers/Riders/Observers; Equestrian Center Employees, Vehicles, Equipment, Contact with horse manure and organic materials, Slip, Trip, and Fall Situations; Soil Contamination and Landfill Trash/Debris; Soil Gas Vapors; Inhalation and Contact with Organic Vapors

**Environmental Hazards:**

**Soil Contamination:** organochlorine pesticides including: 4,4-DDD; 4,4-DDE; and 4,4-DDT and volatile organic compounds

**Vapor Emissions:** volatile organic compounds, hydrogen sulfide, and methane

I acknowledge that I have received a copy of this Health and Safety Plan, that I have read it and received day-specific updated information, have attended the Tailgate Safety Meeting, and agree to comply with the applicable guidance, rules and regulations specified therein.

**Name:**

**Company:**

**Signature:**

ADRIAN GILLES AGI

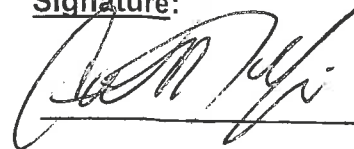

VICTOR ZERMENO J&H



MANUEL GUILLEN J&H

ARON EDWARDS J&H



\_\_\_\_\_

\_\_\_\_\_



File No. 5382-01  
October 6, 2010

**APPENDIX B**

**Boring Logs**

BORING LOG No. AGB-1

F.N. 5382-01

Project Name: Peter Weber Equestrian Center

Sheet: 1 of 1

Location: 26401 Crenshaw Blvd. Rolling Hills Estates, CA

Start: Aug 3, 10

Estimated Surface Elevation: 412' ± Total Depth: 11.5' Rig Type: 8" HSA

End: Aug 3, 10

Depth-Feet	Sample Type	Blow Counts Per Foot	Dry Unit Weight Pcf	Moisture Content %	Laboratory Tests	Field Description	
						USCS Symbol	Graphic Log
0	INTACT BULK					Surface Conditions: <b>Rough grade landfill area, grass covered</b>	By: <b>CG</b>
						Subsurface Conditions: <b>FORMATION: Classification, color, moisture, tightness, etc.</b>	
0-1'						<b>TOPSOIL (0-1')</b> SILT - Tan-gray, dry, loose.	
1'-11.5'						<b>MONTEREY FORMATION (1'-11.5')</b> SILT - Tan-gray, dry, dense.	
11.5'						Total depth = 11.5' No groundwater.	

NOTES: \_\_\_\_\_

Legend:  Bag  
 Ring

American Geotechnical  
 Plate \_\_\_\_\_

Project Name: Peter Weber Equestrian Center

Sheet: 1 of 1

Location: 26401 Crenshaw Blvd. Rolling Hills Estates, CA

Start: Aug 3, 10

Estimated Surface Elevation: 413' ± Total Depth: 16.5' Rig Type: 8" HSA

End: Aug 3, 10

Depth-Feet	Sample Type	Blow Counts Per Foot	Dry Unit Weight Pcf	Moisture Content %	Laboratory Tests	Field Description	
						USCS Symbol	Graphic Log
0	INTACT BULK					Surface Conditions:	Rough grade landfill area, grass covered
						Subsurface Conditions:	<b>FORMATION: Classification, color, moisture, tightness, etc.</b>
0-1'						<b>TOPSOIL (0-1')</b>	Silty SAND - Gray-brown, damp, loose.
1'-5.5'						<b>FILL (1'-5.5')</b>	Silty SAND - Gray-brown, damp, dense.
5.5'-9'		18				<b>COLLUVIUM (5.5'-9')</b>	Silty CLAY - mottled orange-brown, moist, firm.
9'-16.5'		20				<b>MONTEREY FORMATION (9'-16.5')</b>	SILTSTONE - Highly fractured, orange-brown to tan-brown, moist, dense.
16.5'		25					Total depth = 16.5' No groundwater.

NOTES: \_\_\_\_\_

Legend:  Bag  
 Ring

Project Name: Peter Weber Equestrian Center

Sheet: 1 of 2

Location: 26401 Crenshaw Blvd. Rolling Hills Estates, CA

Start: Aug 3, 10

Estimated Surface Elevation: 417' ± Total Depth: 21.5' Rig Type: 8" HSA

End: Aug 3, 10

Depth-Feet	Sample Type	Blow Counts Per Foot	Dry Unit Weight Pcf	Moisture Content %	Laboratory Tests	Field Description		By: <b>CG</b>
						USCS Symbol	Graphic Log	
0	INTACT BULK					Surface Conditions:	<b>Gravel road</b>	
						Subsurface Conditions:	<b>FORMATION: Classification, color, moisture, tightness, etc.</b>	
0-4'						<b>FILL (0-4')</b>	<b>SAND</b> - Medium-coarse grained, light gray, moist, medium dense.	
4-21.5'						<b>MONTEREY FORMATION (4'-21.5')</b>	<b>CLAY</b> - olive-gray, moist, firm, interbedded with olive-gray Silty SAND.	
79							Clayey SAND - light gray, moist, stiff.	
62								
58							CLAY - Mottled orange-brown, moist, stiff, with thin lenses of dark gray organics.	
84							CLAY - orange-brown to olive-brown, moist, stiff, with carbonate pods	
20								

NOTES: \_\_\_\_\_

Legend:  Bag  
 Ring

American Geotechnical  
 Plate \_\_\_\_\_

Depth-Feet	Sample Type	Blow Counts Per Foot	Dry Unit Weight pcf	Moisture Content %	Laboratory Tests	Field Description	
						USCS Symbol	Graphic Log
						Surface Conditions:	By: <b>CG</b>
						<b>Gravel road</b>	
						Subsurface Conditions:	FORMATION: Classification, color, moisture, tightness, etc.
		75					Total depth = 21.5' No groundwater.
25							
30							
35							
40							

Legend:  Bag  
 Ring



Project Name: Peter Weber Equestrian Center

Sheet: 1 of 2

Location: 26401 Crenshaw Blvd. Rolling Hills Estates, CA

Start: Aug 3, 10

Estimated Surface Elevation: 418' ± Total Depth: 20.5' Rig Type: 8" HSA

End: Aug 3, 10

Depth-Feet	Sample Type	Blow Counts Per Foot	Dry Unit Weight Pcf	Moisture Content %	Laboratory Tests	Field Description		By: <b>CG</b>
						USCS Symbol	Graphic Log	
0	INTACT BULK						Surface Conditions: <b>Gravel road</b>	
							Subsurface Conditions: <b>FORMATION: Classification, color, moisture, tightness, etc.</b>	
0-2.5'							<b>FILL (0-2.5')</b> Silty CLAY - Olive-gray, moist, firm.	
2.5'-20.5'							<b>MONTEREY FORMATION (2.5'-20.5')</b> Silty CLAY/Silty SAND - Orange-brown, moist, dense, with carbonate pods.	
5		85						
		80						
10		98					Silty CLAY/Silty SAND - Mottled green to orange-brown, moist, stiff.	
15		95						
20		76						

NOTES: \_\_\_\_\_

Legend:  Bag  
 Ring

American Geotechnical  
 Plate \_\_\_\_\_

Depth-Feet	INTACT BULK	Sample Type	Blow Counts Per Foot	Dry Unit Weight pcf	Moisture Content %	Laboratory Tests	Field Description	
							USCS Symbol	Graphic Log
							Surface Conditions:	By: <b>CG</b>
							<b>Gravel road</b>	
							Subsurface Conditions:	<b>FORMATION: Classification, color, moisture, tightness, etc.</b>
							Total Depth = 20.5' No groundwater.	
25								
30								
35								
40								

Legend:  Bag  
 Ring

Project Name: Peter Weber Equestrian Center

Sheet: 1 of 1

Location: 26401 Crenshaw Blvd. Rolling Hills Estates, CA

Start: Aug 3, 10

Estimated Surface Elevation: 420' ± Total Depth: 20.0' Rig Type: 8" HSA

End: Aug 3, 10

Depth-Feet	Sample Type	Blow Counts Per Foot	Dry Unit Weight Pcf	Moisture Content %	Laboratory Tests	Field Description		By: <b>CG</b>
						USCS Symbol	Graphic Log	
0	INTACT BULK						Surface Conditions: <b>Gravel road</b>	
							Subsurface Conditions: <b>FORMATION: Classification, color, moisture, tightness, etc.</b>	
0-2'							<b>FILL (0-2')</b> CLAY - Blue-gray, moist, firm.	
2-5'		79					<b>COLLUVIUM (2'-5')</b> CLAY - blue-gray, moist, stiff.	
5-20'		74					<b>MONTEREY FORMATION (5'-20')</b> Silty CLAY - Mottled orange-brown to olive-brown, moist, firm, specks of black organics.	
10-15'							CLAY - Mottled olive-brown, moist, stiff, with fragments of chert, some carbonate pods, some organic pods.	
15-20'		69						
20'		88					Silty CLAY -Blue-gray, moist, stiff. Total depth = 20' No groundwater.	

NOTES: \_\_\_\_\_

Legend:  Bag  
 Ring

Project Name: Peter Weber Equestrian Center

Sheet: 1 of 2

Location: 26401 Crenshaw Blvd. Rolling Hills Estates, CA

Start: Aug 3, 10

Estimated Surface Elevation: 421' ± Total Depth: 20.5' Rig Type: 8" HSA

End: Aug 3, 10

Depth-Feet	Sample Type	Blow Counts Per Foot	Dry Unit Weight Pcf	Moisture Content %	Laboratory Tests	Field Description		By: <b>CG</b>
						USCS Symbol	Graphic Log	
0	INTACT BULK						Surface Conditions: <b>Gravel road</b>	
							Subsurface Conditions: <b>FORMATION: Classification, color, moisture, tightness, etc.</b>	
							<b>FILL (0-8')</b> CLAY - mottled black to blue-gray, moist, firm.	
5		29					CLAY - mottled olive-brown, moist, firm, clasts of SANDSTONE.	
		21					<b>MONTEREY FORMATION (8'-20.5')</b> CLAYSTONE/SILTSTONE - Mottled orange-brown, moist, dense.	
10		17						
15		21						
20								

NOTES: \_\_\_\_\_

Legend:  Bag  
 Ring

American Geotechnical  
 Plate \_\_\_\_\_

Project Name: Peter Weber Equestrian Center

Sheet: 2 of 2

Depth-Feet	Sample Type	Blow Counts Per Foot	Dry Unit Weight pcf	Moisture Content %	Laboratory Tests	Field Description	
						USCS Symbol	Graphic Log
						Surface Conditions:	By: <b>CG</b>
						<b>Gravel road</b>	
						Subsurface Conditions:	<b>FORMATION: Classification, color, moisture, tightness, etc.</b>
						Total depth = 20.5' No groundwater.	
25							
30							
35							
40							

Legend:  Bag  
 Ring

File No. 5382-01  
October 6, 2010

**APPENDIX C**

**Analytical Testing of Contained Soil/Rinsate**

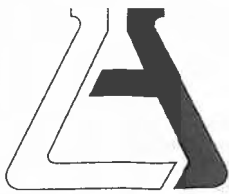

**ASSOCIATED LABORATORIES**

806 North Batavia - Orange, California 92868 - 714/771-6900

FAX 714/538-1209

CLIENT American Geotechnical (13079)  
ATTN: Catherine Glick  
22725 Old Canal Rd.  
Yorba Linda, CA 92887

LAB REQUEST 259142

REPORTED 08/11/2010

RECEIVED 08/05/2010

PROJECT #5382-01  
Peter Weber Equestrian Center

SUBMITTER Client

COMMENTS

This laboratory request covers the following listed samples which were analyzed for the parameters indicated on the attached Analytical Result Report. All analyses were conducted using the appropriate methods as indicated on the report. This cover letter is an integral part of the final report.

<u>Order No.</u>	<u>Client Sample Identification</u>
1100710	Drum # 1
1100711	Drum # 2
1100712	Drum # 3
1100713	Drum # 4
1100714	Drum # 5
1100715	WS 1,2,3
1100716	Laboratory Method Blank
1100717	Laboratory Method Blank

Thank you for the opportunity to be of service to your company. Please feel free to call if there are any questions regarding this report or if we can be of further service.

ASSOCIATED LABORATORIES by,

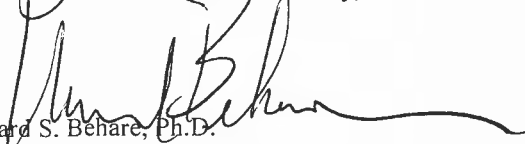
  
Edward S. Behare, Ph.D.  
Vice President

*NOTE: Unless notified in writing, all samples will be discarded by appropriate disposal protocol 30 days from date reported.*

The reports of the Associated Laboratories are confidential property of our clients and may not be reproduced or used for publication in part or in full without our written permission. This is for the mutual protection of the public, our clients, and ourselves.

TESTING & CONSULTING  
Chemical  
Microbiological  
Environmental

Order #: 1100710

Client: American Geotechnical

Matrix: SOLID

Client Sample ID: Drum # 1

Date Sampled: 08/03/2010

Time Sampled: 09:25

Sampled By:

Analyte	Result	DF	DLR	Units	Date/Analyst
---------	--------	----	-----	-------	--------------

**6010B ICP CAM Metals Only (W/S/W)**

Antimony	ND	1	3.0	mg/Kg	08/06/10 KN
Arsenic	3.06	1	1.0	mg/Kg	08/06/10 KN
Barium	771	1	1.0	mg/Kg	08/06/10 KN
Beryllium	0.569	1	0.5	mg/Kg	08/06/10 KN
Cadmium	1.76	1	0.5	mg/Kg	08/06/10 KN
Chromium	41.0	1	1.0	mg/Kg	08/06/10 KN
Cobalt	6.01	1	0.5	mg/Kg	08/06/10 KN
Copper	36.9	1	1.0	mg/Kg	08/06/10 KN
Lead	5.55	1	0.5	mg/Kg	08/06/10 KN
Molybdenum	3.43	1	1.0	mg/Kg	08/06/10 KN
Nickel	35.0	1	1.5	mg/Kg	08/06/10 KN
Selenium	3.46	1	1.0	mg/Kg	08/06/10 KN
Silver	ND	1	0.5	mg/Kg	08/06/10 KN
Thallium	ND	1	1.0	mg/Kg	08/06/10 KN
Vanadium	72.4	1	0.5	mg/Kg	08/06/10 KN
Zinc	64.2	1	5.0	mg/Kg	08/06/10 KN

**7471A Mercury in Solid/Wipe**

Mercury	ND	1	0.14	mg/Kg	08/06/10 NF
---------	----	---	------	-------	-------------

**8015 TEPH Diesel**

TEPH Diesel	ND	1	1.0	mg/Kg	08/09/10 AF
-------------	----	---	-----	-------	-------------

**Surrogates**

				Units	Control Limits
Triacotane (Sur)	73			%	60 - 140

**8081A - Organochlorine Pesticides by GC**

4,4-DDD	ND	1	0.005	mg/Kg	08/06/10 GH
4,4-DDE	ND	1	0.004	mg/Kg	08/06/10 GH
4,4-DDT	ND	1	0.005	mg/Kg	08/06/10 GH
Aldrin	ND	1	0.004	mg/Kg	08/06/10 GH
Alpha BHC	ND	1	0.002	mg/Kg	08/06/10 GH
Beta BHC	ND	1	0.003	mg/Kg	08/06/10 GH
Chlordane	ND	1	0.025	mg/Kg	08/06/10 GH

DLR = Detection limit for reporting purposes, ND = Not Detected below indicated detection limit, DF = Dilution Factor

**ASSOCIATED LABORATORIES**

Analytical Results Report





Order #: 1100710

Client: American Geotechnical

Matrix: SOLID

Client Sample ID: Drum # 1

Date Sampled: 08/03/2010

Time Sampled: 09:25

Sampled By:

Analyte	Result	DF	DLR	Units	Date/Analyst
<b>8081A - Organochlorine Pesticides by GC</b>					
Delta BHC	ND	1	0.005	mg/Kg	08/06/10 GH
Dieldrin	ND	1	0.003	mg/Kg	08/06/10 GH
Endosulfan I	ND	1	0.004	mg/Kg	08/06/10 GH
Endosulfan II	ND	1	0.004	mg/Kg	08/06/10 GH
Endosulfan sulfate	ND	1	0.004	mg/Kg	08/06/10 GH
Endrin	ND	1	0.004	mg/Kg	08/06/10 GH
Endrin aldehyde	ND	1	0.004	mg/Kg	08/06/10 GH
Endrin Ketone	ND	1	0.005	mg/Kg	08/06/10 GH
Heptachlor	ND	1	0.004	mg/Kg	08/06/10 GH
Heptachlor epoxide	ND	1	0.003	mg/Kg	08/06/10 GH
Lindane	ND	1	0.003	mg/Kg	08/06/10 GH
Methoxychlor	ND	1	0.025	mg/Kg	08/06/10 GH
Toxaphene	ND	1	0.250	mg/Kg	08/06/10 GH
<b>Surrogates</b>				<b>Units</b>	<b>Control Limits</b>
DCB (Sur2)	126			%	55 - 135
TCMX (Sur1)	111			%	50 - 125

**8260B Volatile Organic Compounds**

1,1,1,2-Tetrachloroethane	ND	1	5	ug/Kg	08/06/10 NZ
1,1,1-Trichloroethane	ND	1	5	ug/Kg	08/06/10 NZ
1,1,2,2-Tetrachloroethane	ND	1	5	ug/Kg	08/06/10 NZ
1,1,2-Trichloroethane	ND	1	5	ug/Kg	08/06/10 NZ
1,1,2-Trichlorotrifluoroethane	ND	1	5	ug/Kg	08/06/10 NZ
1,1-Dichloroethane	ND	1	5	ug/Kg	08/06/10 NZ
1,1-Dichloroethene	ND	1	5	ug/Kg	08/06/10 NZ
1,1-Dichloropropene	ND	1	5	ug/Kg	08/06/10 NZ
1,2,3-Trichlorobenzene	ND	1	5	ug/Kg	08/06/10 NZ
1,2,3-Trichloropropane	ND	1	5	ug/Kg	08/06/10 NZ
1,2,4-Trichlorobenzene	ND	1	5	ug/Kg	08/06/10 NZ
1,2,4-Trimethylbenzene	ND	1	5	ug/Kg	08/06/10 NZ
1,2-Dibromo-3-chloropropane	ND	1	5	ug/Kg	08/06/10 NZ
1,2-Dibromoethane	ND	1	5	ug/Kg	08/06/10 NZ
1,2-Dichlorobenzene	ND	1	5	ug/Kg	08/06/10 NZ
1,2-Dichloroethane	ND	1	5	ug/Kg	08/06/10 NZ
1,2-Dichloropropane	ND	1	5	ug/Kg	08/06/10 NZ
1,3,5-Trimethylbenzene	ND	1	5	ug/Kg	08/06/10 NZ
1,3-Dichlorobenzene	ND	1	5	ug/Kg	08/06/10 NZ

DLR = Detection limit for reporting purposes, ND = Not Detected below indicated detection limit, DF = Dilution Factor

**ASSOCIATED LABORATORIES**

Analytical Results Report



Order #: 1100710

Client: American Geotechnical

Matrix: SOLID

Client Sample ID: Drum # 1

Date Sampled: 08/03/2010

Time Sampled: 09:25

Sampled By:

Analyte	Result	DF	DLR	Units	Date/Analyst
<b>8260B Volatile Organic Compounds</b>					
1,3-Dichloropropane	ND	1	5	ug/Kg	08/06/10 NZ
1,4-Dichlorobenzene	ND	1	5	ug/Kg	08/06/10 NZ
2,2-Dichloropropane	ND	1	5	ug/Kg	08/06/10 NZ
2-Butanone (MEK)	ND	1	100	ug/Kg	08/06/10 NZ
2-Chloroethyl vinyl ether	ND	1	5	ug/Kg	08/06/10 NZ
2-Chlorotoluene	ND	1	5	ug/Kg	08/06/10 NZ
4-Chlorotoluene	ND	1	5	ug/Kg	08/06/10 NZ
4-Methyl -2- Pentanone (MIBK)	ND	1	5	ug/Kg	08/06/10 NZ
Acetone	ND	1	50	ug/Kg	08/06/10 NZ
Allyl chloride	ND	1	5	ug/Kg	08/06/10 NZ
Benzene	ND	1	5	ug/Kg	08/06/10 NZ
Bromobenzene	ND	1	5	ug/Kg	08/06/10 NZ
Bromochloromethane	ND	1	5	ug/Kg	08/06/10 NZ
Bromodichloromethane	ND	1	5	ug/Kg	08/06/10 NZ
Bromoform	ND	1	5	ug/Kg	08/06/10 NZ
Bromomethane	ND	1	5	ug/Kg	08/06/10 NZ
Carbon tetrachloride	ND	1	5	ug/Kg	08/06/10 NZ
Chlorobenzene	ND	1	5	ug/Kg	08/06/10 NZ
Chloroethane	ND	1	5	ug/Kg	08/06/10 NZ
Chloroform	ND	1	5	ug/Kg	08/06/10 NZ
Chloromethane	ND	1	5	ug/Kg	08/06/10 NZ
cis-1,2-Dichloroethene	ND	1	5	ug/Kg	08/06/10 NZ
cis-1,3-Dichloropropene	ND	1	5	ug/Kg	08/06/10 NZ
cis-1,4-Dichloro-2-butene	ND	1	5	ug/Kg	08/06/10 NZ
Dibromochloromethane	ND	1	5	ug/Kg	08/06/10 NZ
Dibromomethane	ND	1	5	ug/Kg	08/06/10 NZ
Dichlorodifluoromethane	ND	1	5	ug/Kg	08/06/10 NZ
Ethyl benzene	ND	1	5	ug/Kg	08/06/10 NZ
Hexachlorobutadiene	ND	1	5	ug/Kg	08/06/10 NZ
Isopropylbenzene (Cumene)	ND	1	5	ug/Kg	08/06/10 NZ
m and p-Xylene	ND	1	5	ug/Kg	08/06/10 NZ
Methyl-tert-butylether (MTBE)	ND	1	5	ug/Kg	08/06/10 NZ
Methylene chloride	ND	1	5	ug/Kg	08/06/10 NZ
n-Butylbenzene	ND	1	5	ug/Kg	08/06/10 NZ
n-Propylbenzene	ND	1	5	ug/Kg	08/06/10 NZ
Naphthalene	ND	1	5	ug/Kg	08/06/10 NZ
o-Xylene	ND	1	5	ug/Kg	08/06/10 NZ
p-Isopropyltoluene	ND	1	5	ug/Kg	08/06/10 NZ
sec-Butylbenzene	ND	1	5	ug/Kg	08/06/10 NZ

DLR = Detection limit for reporting purposes, ND = Not Detected below indicated detection limit, DF = Dilution Factor

**ASSOCIATED LABORATORIES**

Analytical Results Report



Order #: 1100710

Client: American Geotechnical

Matrix: SOLID

Client Sample ID: Drum # 1

Date Sampled: 08/03/2010

Time Sampled: 09:25

Sampled By:

Analyte	Result	DF	DLR	Units	Date/Analyst
<b>8260B Volatile Organic Compounds</b>					
Styrene	ND	1	5	ug/Kg	08/06/10 NZ
tert-Butylbenzene	ND	1	5	ug/Kg	08/06/10 NZ
Tetrachloroethene	ND	1	5	ug/Kg	08/06/10 NZ
Toluene	ND	1	5	ug/Kg	08/06/10 NZ
trans-1,2-Dichloroethene	ND	1	5	ug/Kg	08/06/10 NZ
trans-1,3-Dichloropropene	ND	1	5	ug/Kg	08/06/10 NZ
trans-1,4-Dichloro-2-butene	ND	1	5	ug/Kg	08/06/10 NZ
Trichloroethene	ND	1	5	ug/Kg	08/06/10 NZ
Trichlorofluoromethane	ND	1	5	ug/Kg	08/06/10 NZ
Vinyl chloride	ND	1	5	ug/Kg	08/06/10 NZ
Xylenes, total	ND	1	5	ug/Kg	08/06/10 NZ
Di-isopropyl ether (DIPE)	ND	1	2.0	ug/Kg	08/06/10 NZ
Ethyl-tertbutylether (ETBE)	ND	1	2.0	ug/Kg	08/06/10 NZ
Tert-amylmethylether (TAME)	ND	1	2.0	ug/Kg	08/06/10 NZ
Tertiary butyl alcohol (TBA)	ND	1	10	ug/Kg	08/06/10 NZ

**Surrogates**

			Units	Control Limits
Surr1 - Dibromofluoromethane	101		%	70 - 135
Surr2 - 1,2-Dichloroethane-d4	98		%	70 - 135
Surr3 - Toluene-d8	104		%	70 - 135
Surr4 - p-Bromofluorobenzene	101		%	70 - 135

**8270C Acid/Base/Neutral Extractables**

1,2,4-Trichlorobenzene	ND	1	300	ug/Kg	08/09/10 SD
1,2-Dichlorobenzene	ND	1	300	ug/Kg	08/09/10 SD
1,3-Dichlorobenzene	ND	1	300	ug/Kg	08/09/10 SD
1,4-Dichlorobenzene	ND	1	300	ug/Kg	08/09/10 SD
2,4,5-Trichlorophenol	ND	1	300	ug/Kg	08/09/10 SD
2,4,6-Trichlorophenol	ND	1	300	ug/Kg	08/09/10 SD
2,4-Dichlorophenol	ND	1	300	ug/Kg	08/09/10 SD
2,4-Dimethylphenol	ND	1	300	ug/Kg	08/09/10 SD
2,4-Dinitrophenol	ND	1	300	ug/Kg	08/09/10 SD
2,4-Dinitrotoluene	ND	1	300	ug/Kg	08/09/10 SD
2,6-Dinitrotoluene	ND	1	300	ug/Kg	08/09/10 SD
2-Chloronaphthalene	ND	1	300	ug/Kg	08/09/10 SD
2-Chlorophenol	ND	1	300	ug/Kg	08/09/10 SD
2-Methylnaphthalene	ND	1	300	ug/Kg	08/09/10 SD
2-Methylphenol	ND	1	300	ug/Kg	08/09/10 SD

DLR = Detection limit for reporting purposes, ND = Not Detected below indicated detection limit, DF = Dilution Factor

**ASSOCIATED LABORATORIES**

Analytical Results Report



Order #: 1100710

Client: American Geotechnical

Matrix: SOLID

Client Sample ID: Drum # 1

Date Sampled: 08/03/2010

Time Sampled: 09:25

Sampled By:

Analyte	Result	DF	DLR	Units	Date/Analyst
<b>8270C Acid/Base/Neutral Extractables</b>					
2-Nitroaniline	ND	1	300	ug/Kg	08/09/10 SD
2-Nitrophenol	ND	1	300	ug/Kg	08/09/10 SD
3,3-Dichlorobenzidine	ND	1	300	ug/Kg	08/09/10 SD
3-Methylphenol	ND	1	500	ug/Kg	08/09/10 SD
3-Nitroaniline	ND	1	300	ug/Kg	08/09/10 SD
4,6-Dinitro-2-methylphenol	ND	1	300	ug/Kg	08/09/10 SD
4-Bromophenyl-phenylether	ND	1	300	ug/Kg	08/09/10 SD
4-Chloro-3-methylphenol	ND	1	300	ug/Kg	08/09/10 SD
4-Chloroaniline	ND	1	300	ug/Kg	08/09/10 SD
4-Chlorophenyl-phenylether	ND	1	300	ug/Kg	08/09/10 SD
4-Methylphenol	ND	1	500	ug/Kg	08/09/10 SD
4-Nitroaniline	ND	1	300	ug/Kg	08/09/10 SD
4-Nitrophenol	ND	1	300	ug/Kg	08/09/10 SD
Acenaphthene	ND	1	300	ug/Kg	08/09/10 SD
Acenaphthylene	ND	1	300	ug/Kg	08/09/10 SD
Anthracene	ND	1	300	ug/Kg	08/09/10 SD
Benzidine	ND	1	1500	ug/Kg	08/09/10 SD
Benzo(a)anthracene	ND	1	300	ug/Kg	08/09/10 SD
Benzo(a)pyrene	ND	1	300	ug/Kg	08/09/10 SD
Benzo(b)fluoranthene	ND	1	300	ug/Kg	08/09/10 SD
Benzo(g,h,i)perylene	ND	1	300	ug/Kg	08/09/10 SD
Benzo(k)fluoranthene	ND	1	300	ug/Kg	08/09/10 SD
Benzoic Acid	ND	1	300	ug/Kg	08/09/10 SD
Benzyl alcohol	ND	1	300	ug/Kg	08/09/10 SD
bis(2-Chloroethoxy)methane	ND	1	300	ug/Kg	08/09/10 SD
bis(2-Chloroethyl)ether	ND	1	300	ug/Kg	08/09/10 SD
bis(2-Chloroisopropyl) ether	ND	1	300	ug/Kg	08/09/10 SD
bis(2-Ethylhexyl)phthalate	ND	1	300	ug/Kg	08/09/10 SD
Butylbenzylphthalate	ND	1	300	ug/Kg	08/09/10 SD
Chrysene	ND	1	300	ug/Kg	08/09/10 SD
Di-n-butylphthalate	ND	1	300	ug/Kg	08/09/10 SD
Di-n-octylphthalate	ND	1	300	ug/Kg	08/09/10 SD
Dibenz(a,h)anthracene	ND	1	300	ug/Kg	08/09/10 SD
Dibenzofuran	ND	1	300	ug/Kg	08/09/10 SD
Diethylphthalate	ND	1	300	ug/Kg	08/09/10 SD
Dimethylphthalate	ND	1	300	ug/Kg	08/09/10 SD
Fluoranthene	ND	1	300	ug/Kg	08/09/10 SD
Fluorene	ND	1	300	ug/Kg	08/09/10 SD
Hexachlorobenzene	ND	1	300	ug/Kg	08/09/10 SD

DLR = Detection limit for reporting purposes, ND = Not Detected below indicated detection limit, DF = Dilution Factor



Order #: 1100710

Client: American Geotechnical

Matrix: SOLID

Client Sample ID: Drum # 1

Date Sampled: 08/03/2010

Time Sampled: 09:25

Sampled By:

Analyte	Result	DF	DLR	Units	Date/Analyst
---------	--------	----	-----	-------	--------------

**8270C Acid/Base/Neutral Extractables**

Hexachlorobutadiene	ND	1	300	ug/Kg	08/09/10 SD
Hexachlorocyclopentadiene	ND	1	300	ug/Kg	08/09/10 SD
Hexachloroethane	ND	1	300	ug/Kg	08/09/10 SD
Indeno(1,2,3-c,d)pyrene	ND	1	300	ug/Kg	08/09/10 SD
Isophorone	ND	1	300	ug/Kg	08/09/10 SD
N-Nitroso-di-n-propylamine	ND	1	300	ug/Kg	08/09/10 SD
N-Nitrosodiphenylamine	ND	1	300	ug/Kg	08/09/10 SD
Naphthalene	ND	1	300	ug/Kg	08/09/10 SD
Nitrobenzene	ND	1	300	ug/Kg	08/09/10 SD
Pentachlorophenol	ND	1	300	ug/Kg	08/09/10 SD
Phenanthrene	ND	1	300	ug/Kg	08/09/10 SD
Phenol	ND	1	300	ug/Kg	08/09/10 SD
Pyrene	ND	1	300	ug/Kg	08/09/10 SD

**Surrogates**

				Units	Control Limits
2,4,6-Tribromophenol (sur)	60			%	17 - 122
2-Fluorobiphenyl (sur)	70			%	30 - 115
2-Fluorophenol (sur)	65			%	25 - 121
Nitrobenzene-d5 (sur)	59			%	23 - 120
Phenol-d5 (sur)	62			%	24 - 113
Terphenyl-d14 (sur)	82			%	18 - 137

**8015B - Gasoline**

Gasoline	ND	1	3	mg/Kg	08/06/10 LT
----------	----	---	---	-------	-------------

**Surrogates**

				Units	Control Limits
p-Bromofluorobenzene (Sur)	135			%	60 - 140

DLR = Detection limit for reporting purposes, ND = Not Detected below indicated detection limit, DF = Dilution Factor

**ASSOCIATED LABORATORIES**

Analytical Results Report



Order #: 1100711

Client: American Geotechnical

Matrix: SOLID

Client Sample ID: Drum # 2

Date Sampled: 08/03/2010

Time Sampled: 10:45

Sampled By:

Analyte	Result	DF	DLR	Units	Date/Analyst
---------	--------	----	-----	-------	--------------

**6010B ICP CAM Metals Only (W/S/W)**

Antimony	ND	1	3.0	mg/Kg	08/06/10	KN
Arsenic	7.46	1	1.0	mg/Kg	08/06/10	KN
Barium	811	1	1.0	mg/Kg	08/06/10	KN
Beryllium	0.621	1	0.5	mg/Kg	08/06/10	KN
Cadmium	1.55	1	0.5	mg/Kg	08/06/10	KN
Chromium	42.6	1	1.0	mg/Kg	08/06/10	KN
Cobalt	6.95	1	0.5	mg/Kg	08/06/10	KN
Copper	28.7	1	1.0	mg/Kg	08/06/10	KN
Lead	6.67	1	0.5	mg/Kg	08/06/10	KN
Molybdenum	4.89	1	1.0	mg/Kg	08/06/10	KN
Nickel	38.8	1	1.5	mg/Kg	08/06/10	KN
Selenium	3.67	1	1.0	mg/Kg	08/06/10	KN
Silver	ND	1	0.5	mg/Kg	08/06/10	KN
Thallium	ND	1	1.0	mg/Kg	08/06/10	KN
Vanadium	65.6	1	0.5	mg/Kg	08/06/10	KN
Zinc	75.5	1	5.0	mg/Kg	08/06/10	KN

**7471A Mercury in Solid/Wipe**

Mercury	ND	1	0.14	mg/Kg	08/06/10	NF
---------	----	---	------	-------	----------	----

**8015 TEPH Diesel**

TEPH Diesel	14	5	5.0	mg/Kg	08/09/10	AF
-------------	----	---	-----	-------	----------	----

**Surrogates**

				Units	Control Limits
Triacontane (Sur)	67			%	60 - 140

**8081A - Organochlorine Pesticides by GC**

4,4-DDD	ND	1	0.005	mg/Kg	08/06/10	GH
4,4-DDE	0.0042	1	0.004	mg/Kg	08/06/10	GH
4,4-DDT	ND	1	0.005	mg/Kg	08/06/10	GH
Aldrin	ND	1	0.004	mg/Kg	08/06/10	GH
Alpha BHC	ND	1	0.002	mg/Kg	08/06/10	GH
Beta BHC	ND	1	0.003	mg/Kg	08/06/10	GH
Chlordane	ND	1	0.025	mg/Kg	08/06/10	GH

DLR = Detection limit for reporting purposes, ND = Not Detected below indicated detection limit, DF = Dilution Factor

**ASSOCIATED LABORATORIES**

Analytical Results Report



Order #: 1100711

Client: American Geotechnical

Matrix: SOLID

Client Sample ID: Drum # 2

Date Sampled: 08/03/2010

Time Sampled: 10:45

Sampled By:

Analyte	Result	DF	DLR	Units	Date/Analyst
<b>8081A - Organochlorine Pesticides by GC</b>					
Delta BHC	ND	1	0.005	mg/Kg	08/06/10 GH
Dieldrin	ND	1	0.003	mg/Kg	08/06/10 GH
Endosulfan I	ND	1	0.004	mg/Kg	08/06/10 GH
Endosulfan II	ND	1	0.004	mg/Kg	08/06/10 GH
Endosulfan sulfate	ND	1	0.004	mg/Kg	08/06/10 GH
Endrin	ND	1	0.004	mg/Kg	08/06/10 GH
Endrin aldehyde	ND	1	0.004	mg/Kg	08/06/10 GH
Endrin Ketone	ND	1	0.005	mg/Kg	08/06/10 GH
Heptachlor	ND	1	0.004	mg/Kg	08/06/10 GH
Heptachlor epoxide	ND	1	0.003	mg/Kg	08/06/10 GH
Lindane	ND	1	0.003	mg/Kg	08/06/10 GH
Methoxychlor	ND	1	0.025	mg/Kg	08/06/10 GH
Toxaphene	ND	1	0.250	mg/Kg	08/06/10 GH
<b>Surrogates</b>				<b>Units</b>	<b>Control Limits</b>
DCB(Sur2)	104			%	55 - 135
TCMX (Sur1)	109			%	50 - 125

**8260B Volatile Organic Compounds**

1,1,1,2-Tetrachloroethane	ND	1	5	ug/Kg	08/06/10 NZ
1,1,1-Trichloroethane	ND	1	5	ug/Kg	08/06/10 NZ
1,1,2,2-Tetrachloroethane	ND	1	5	ug/Kg	08/06/10 NZ
1,1,2-Trichloroethane	ND	1	5	ug/Kg	08/06/10 NZ
1,1,2-Trichlorotrifluoroethane	ND	1	5	ug/Kg	08/06/10 NZ
1,1-Dichloroethane	ND	1	5	ug/Kg	08/06/10 NZ
1,1-Dichloroethene	ND	1	5	ug/Kg	08/06/10 NZ
1,1-Dichloropropene	ND	1	5	ug/Kg	08/06/10 NZ
1,2,3-Trichlorobenzene	ND	1	5	ug/Kg	08/06/10 NZ
1,2,3-Trichloropropane	ND	1	5	ug/Kg	08/06/10 NZ
1,2,4-Trichlorobenzene	ND	1	5	ug/Kg	08/06/10 NZ
1,2,4-Trimethylbenzene	ND	1	5	ug/Kg	08/06/10 NZ
1,2-Dibromo-3-chloropropane	ND	1	5	ug/Kg	08/06/10 NZ
1,2-Dibromoethane	ND	1	5	ug/Kg	08/06/10 NZ
1,2-Dichlorobenzene	ND	1	5	ug/Kg	08/06/10 NZ
1,2-Dichloroethane	ND	1	5	ug/Kg	08/06/10 NZ
1,2-Dichloropropane	ND	1	5	ug/Kg	08/06/10 NZ
1,3,5-Trimethylbenzene	ND	1	5	ug/Kg	08/06/10 NZ
1,3-Dichlorobenzene	ND	1	5	ug/Kg	08/06/10 NZ

DLR = Detection limit for reporting purposes, ND = Not Detected below indicated detection limit, DF = Dilution Factor

**ASSOCIATED LABORATORIES**

Analytical Results Report



Order #: 1100711

Client: American Geotechnical

Matrix: SOLID

Client Sample ID: Drum # 2

Date Sampled: 08/03/2010

Time Sampled: 10:45

Sampled By:

Analyte	Result	DF	DLR	Units	Date/Analyst
<b>8260B Volatile Organic Compounds</b>					
1,3-Dichloropropane	ND	1	5	ug/Kg	08/06/10 NZ
1,4-Dichlorobenzene	ND	1	5	ug/Kg	08/06/10 NZ
2,2-Dichloropropane	ND	1	5	ug/Kg	08/06/10 NZ
2-Butanone (MEK)	ND	1	100	ug/Kg	08/06/10 NZ
2-Chloroethyl vinyl ether	ND	1	5	ug/Kg	08/06/10 NZ
2-Chlorotoluene	ND	1	5	ug/Kg	08/06/10 NZ
4-Chlorotoluene	ND	1	5	ug/Kg	08/06/10 NZ
4-Methyl -2- Pentanone (MIBK)	ND	1	5	ug/Kg	08/06/10 NZ
Acetone	ND	1	50	ug/Kg	08/06/10 NZ
Allyl chloride	ND	1	5	ug/Kg	08/06/10 NZ
Benzene	ND	1	5	ug/Kg	08/06/10 NZ
Bromobenzene	ND	1	5	ug/Kg	08/06/10 NZ
Bromochloromethane	ND	1	5	ug/Kg	08/06/10 NZ
Bromodichloromethane	ND	1	5	ug/Kg	08/06/10 NZ
Bromoform	ND	1	5	ug/Kg	08/06/10 NZ
Bromomethane	ND	1	5	ug/Kg	08/06/10 NZ
Carbon tetrachloride	ND	1	5	ug/Kg	08/06/10 NZ
Chlorobenzene	ND	1	5	ug/Kg	08/06/10 NZ
Chloroethane	ND	1	5	ug/Kg	08/06/10 NZ
Chloroform	ND	1	5	ug/Kg	08/06/10 NZ
Chloromethane	ND	1	5	ug/Kg	08/06/10 NZ
cis-1,2-Dichloroethene	ND	1	5	ug/Kg	08/06/10 NZ
cis-1,3-Dichloropropene	ND	1	5	ug/Kg	08/06/10 NZ
cis-1,4-Dichloro-2-butene	ND	1	5	ug/Kg	08/06/10 NZ
Dibromochloromethane	ND	1	5	ug/Kg	08/06/10 NZ
Dibromomethane	ND	1	5	ug/Kg	08/06/10 NZ
Dichlorodifluoromethane	ND	1	5	ug/Kg	08/06/10 NZ
Ethyl benzene	ND	1	5	ug/Kg	08/06/10 NZ
Hexachlorobutadiene	ND	1	5	ug/Kg	08/06/10 NZ
Isopropylbenzene (Cumene)	ND	1	5	ug/Kg	08/06/10 NZ
m and p-Xylene	ND	1	5	ug/Kg	08/06/10 NZ
Methyl-tert-butylether (MTBE)	ND	1	5	ug/Kg	08/06/10 NZ
Methylene chloride	ND	1	5	ug/Kg	08/06/10 NZ
n-Butylbenzene	ND	1	5	ug/Kg	08/06/10 NZ
n-Propylbenzene	ND	1	5	ug/Kg	08/06/10 NZ
Naphthalene	ND	1	5	ug/Kg	08/06/10 NZ
o-Xylene	ND	1	5	ug/Kg	08/06/10 NZ
p-Isopropyltoluene	ND	1	5	ug/Kg	08/06/10 NZ
sec-Butylbenzene	ND	1	5	ug/Kg	08/06/10 NZ

DLR = Detection limit for reporting purposes, ND = Not Detected below indicated detection limit, DF = Dilution Factor

**ASSOCIATED LABORATORIES**

Analytical Results Report





Order #: 1100711

Client: American Geotechnical

Matrix: SOLID

Client Sample ID: Drum # 2

Date Sampled: 08/03/2010

Time Sampled: 10:45

Sampled By:

Analyte	Result	DF	DLR	Units	Date/Analyst
<b>8260B Volatile Organic Compounds</b>					
Styrene	ND	1	5	ug/Kg	08/06/10 NZ
tert-Butylbenzene	ND	1	5	ug/Kg	08/06/10 NZ
Tetrachloroethene	ND	1	5	ug/Kg	08/06/10 NZ
Toluene	ND	1	5	ug/Kg	08/06/10 NZ
trans-1,2-Dichloroethene	ND	1	5	ug/Kg	08/06/10 NZ
trans-1,3-Dichloropropene	ND	1	5	ug/Kg	08/06/10 NZ
trans-1,4-Dichloro-2-butene	ND	1	5	ug/Kg	08/06/10 NZ
Trichloroethene	ND	1	5	ug/Kg	08/06/10 NZ
Trichlorofluoromethane	ND	1	5	ug/Kg	08/06/10 NZ
Vinyl chloride	ND	1	5	ug/Kg	08/06/10 NZ
Xylenes, total	ND	1	5	ug/Kg	08/06/10 NZ
Di-isopropyl ether (DIPE)	ND	1	2.0	ug/Kg	08/06/10 NZ
Ethyl-tertbutylether (ETBE)	ND	1	2.0	ug/Kg	08/06/10 NZ
Tert-amylmethylether (TAME)	ND	1	2.0	ug/Kg	08/06/10 NZ
Tertiary butyl alcohol (TBA)	ND	1	10	ug/Kg	08/06/10 NZ

**Surrogates**

			Units	Control Limits
Surr1 - Dibromofluoromethane	102		%	70 - 135
Surr2 - 1,2-Dichloroethane-d4	106		%	70 - 135
Surr3 - Toluene-d8	106		%	70 - 135
Surr4 - p-Bromofluorobenzene	98		%	70 - 135

**8270C Acid/Base/Neutral Extractables**

1,2,4-Trichlorobenzene	ND	5	1500.0	ug/Kg	08/09/10 SD
1,2-Dichlorobenzene	ND	5	1500.0	ug/Kg	08/09/10 SD
1,3-Dichlorobenzene	ND	5	1500.0	ug/Kg	08/09/10 SD
1,4-Dichlorobenzene	ND	5	1500.0	ug/Kg	08/09/10 SD
2,4,5-Trichlorophenol	ND	5	1500.0	ug/Kg	08/09/10 SD
2,4,6-Trichlorophenol	ND	5	1500.0	ug/Kg	08/09/10 SD
2,4-Dichlorophenol	ND	5	1500.0	ug/Kg	08/09/10 SD
2,4-Dimethylphenol	ND	5	1500.0	ug/Kg	08/09/10 SD
2,4-Dinitrophenol	ND	5	1500.0	ug/Kg	08/09/10 SD
2,4-Dinitrotoluene	ND	5	1500.0	ug/Kg	08/09/10 SD
2,6-Dinitrotoluene	ND	5	1500.0	ug/Kg	08/09/10 SD
2-Chloronaphthalene	ND	5	1500.0	ug/Kg	08/09/10 SD
2-Chlorophenol	ND	5	1500.0	ug/Kg	08/09/10 SD
2-Methylnaphthalene	ND	5	1500.0	ug/Kg	08/09/10 SD
2-Methylphenol	ND	5	1500.0	ug/Kg	08/09/10 SD

DLR = Detection limit for reporting purposes, ND = Not Detected below indicated detection limit, DF = Dilution Factor

**ASSOCIATED LABORATORIES**

Analytical Results Report



Order #: 1100711

Client: American Geotechnical

Matrix: SOLID

Client Sample ID: Drum # 2

Date Sampled: 08/03/2010

Time Sampled: 10:45

Sampled By:

Analyte	Result	DF	DLR	Units	Date/Analyst
<b>8270C Acid/Base/Neutral Extractables</b>					
2-Nitroaniline	ND	5	1500.0	ug/Kg	08/09/10 SD
2-Nitrophenol	ND	5	1500.0	ug/Kg	08/09/10 SD
3,3-Dichlorobenzidine	ND	5	1500.0	ug/Kg	08/09/10 SD
3-Methylphenol	ND	5	2500.0	ug/Kg	08/09/10 SD
3-Nitroaniline	ND	5	1500.0	ug/Kg	08/09/10 SD
4,6-Dinitro-2-methylphenol	ND	5	1500.0	ug/Kg	08/09/10 SD
4-Bromophenyl-phenylether	ND	5	1500.0	ug/Kg	08/09/10 SD
4-Chloro-3-methylphenol	ND	5	1500.0	ug/Kg	08/09/10 SD
4-Chloroaniline	ND	5	1500.0	ug/Kg	08/09/10 SD
4-Chlorophenyl-phenylether	ND	5	1500.0	ug/Kg	08/09/10 SD
4-Methylphenol	ND	5	2500.0	ug/Kg	08/09/10 SD
4-Nitroaniline	ND	5	1500.0	ug/Kg	08/09/10 SD
4-Nitrophenol	ND	5	1500.0	ug/Kg	08/09/10 SD
Acenaphthene	ND	5	1500.0	ug/Kg	08/09/10 SD
Acenaphthylene	ND	5	1500.0	ug/Kg	08/09/10 SD
Anthracene	ND	5	1500.0	ug/Kg	08/09/10 SD
Benzidine	ND	5	7500.0	ug/Kg	08/09/10 SD
Benzo(a)anthracene	ND	5	1500.0	ug/Kg	08/09/10 SD
Benzo(a)pyrene	ND	5	1500.0	ug/Kg	08/09/10 SD
Benzo(b)fluoranthene	ND	5	1500.0	ug/Kg	08/09/10 SD
Benzo(g,h,i)perylene	ND	5	1500.0	ug/Kg	08/09/10 SD
Benzo(k)fluoranthene	ND	5	1500.0	ug/Kg	08/09/10 SD
Benzoic Acid	ND	5	1500.0	ug/Kg	08/09/10 SD
Benzyl alcohol	ND	5	1500.0	ug/Kg	08/09/10 SD
bis(2-Chloroethoxy)methane	ND	5	1500.0	ug/Kg	08/09/10 SD
bis(2-Chloroethyl)ether	ND	5	1500.0	ug/Kg	08/09/10 SD
bis(2-Chloroisopropyl) ether	ND	5	1500.0	ug/Kg	08/09/10 SD
bis(2-Ethylhexyl)phthalate	ND	5	1500.0	ug/Kg	08/09/10 SD
Butylbenzylphthalate	ND	5	1500.0	ug/Kg	08/09/10 SD
Chrysene	ND	5	1500.0	ug/Kg	08/09/10 SD
Di-n-butylphthalate	ND	5	1500.0	ug/Kg	08/09/10 SD
Di-n-octylphthalate	ND	5	1500.0	ug/Kg	08/09/10 SD
Dibenz(a,h)anthracene	ND	5	1500.0	ug/Kg	08/09/10 SD
Dibenzofuran	ND	5	1500.0	ug/Kg	08/09/10 SD
Diethylphthalate	ND	5	1500.0	ug/Kg	08/09/10 SD
Dimethylphthalate	ND	5	1500.0	ug/Kg	08/09/10 SD
Fluoranthene	ND	5	1500.0	ug/Kg	08/09/10 SD
Fluorene	ND	5	1500.0	ug/Kg	08/09/10 SD
Hexachlorobenzene	ND	5	1500.0	ug/Kg	08/09/10 SD

DLR = Detection limit for reporting purposes, ND = Not Detected below indicated detection limit, DF = Dilution Factor

**ASSOCIATED LABORATORIES**

Analytical Results Report



Order #: 1100711

Client: American Geotechnical

Matrix: SOLID

Client Sample ID: Drum # 2

Date Sampled: 08/03/2010

Time Sampled: 10:45

Sampled By:

Analyte	Result	DF	DLR	Units	Date/Analyst
---------	--------	----	-----	-------	--------------

**8270C Acid/Base/Neutral Extractables**

Hexachlorobutadiene	ND	5	1500.0	ug/Kg	08/09/10 SD
Hexachlorocyclopentadiene	ND	5	1500.0	ug/Kg	08/09/10 SD
Hexachloroethane	ND	5	1500.0	ug/Kg	08/09/10 SD
Indeno(1,2,3-c,d)pyrene	ND	5	1500.0	ug/Kg	08/09/10 SD
Isophorone	ND	5	1500.0	ug/Kg	08/09/10 SD
N-Nitroso-di-n-propylamine	ND	5	1500.0	ug/Kg	08/09/10 SD
N-Nitrosodiphenylamine	ND	5	1500.0	ug/Kg	08/09/10 SD
Naphthalene	ND	5	1500.0	ug/Kg	08/09/10 SD
Nitrobenzene	ND	5	1500.0	ug/Kg	08/09/10 SD
Pentachlorophenol	ND	5	1500.0	ug/Kg	08/09/10 SD
Phenanthrene	ND	5	1500.0	ug/Kg	08/09/10 SD
Phenol	ND	5	1500.0	ug/Kg	08/09/10 SD
Pyrene	ND	5	1500.0	ug/Kg	08/09/10 SD

**Surrogates**

				Units	Control Limits
2,4,6-Tribromophenol (sur)	96			%	17 - 122
2-Fluorobiphenyl (sur)	77			%	30 - 115
2-Fluorophenol (sur)	81			%	25 - 121
Nitrobenzene-d5 (sur)	65			%	23 - 120
Phenol-d5 (sur)	85			%	24 - 113
Terphenyl-d14 (sur)	88			%	18 - 137

**8015B - Gasoline**

Gasoline	ND	1	3	mg/Kg	08/06/10 LT
----------	----	---	---	-------	-------------

**Surrogates**

				Units	Control Limits
p-Bromofluorobenzene (Sur)	139			%	60 - 140

DLR = Detection limit for reporting purposes, ND = Not Detected below indicated detection limit, DF = Dilution Factor

**ASSOCIATED LABORATORIES**

Analytical Results Report



Order #: 1100712

Client: American Geotechnical

Matrix: SOLID

Client Sample ID: Drum # 3

Date Sampled: 08/03/2010

Time Sampled: 13:10

Sampled By:

Analyte	Result	DF	DLR	Units	Date/Analyst
---------	--------	----	-----	-------	--------------

**6010B ICP CAM Metals Only (W/S/W)**

Antimony	ND	1	3.0	mg/Kg	08/06/10	KN
Arsenic	7.99	1	1.0	mg/Kg	08/06/10	KN
Barium	790	1	1.0	mg/Kg	08/06/10	KN
Beryllium	0.601	1	0.5	mg/Kg	08/06/10	KN
Cadmium	1.91	1	0.5	mg/Kg	08/06/10	KN
Chromium	62.5	1	1.0	mg/Kg	08/06/10	KN
Cobalt	9.79	1	0.5	mg/Kg	08/06/10	KN
Copper	50.7	1	1.0	mg/Kg	08/06/10	KN
Lead	6.26	1	0.5	mg/Kg	08/06/10	KN
Molybdenum	4.89	1	1.0	mg/Kg	08/06/10	KN
Nickel	62.1	1	1.5	mg/Kg	08/06/10	KN
Selenium	1.61	1	1.0	mg/Kg	08/06/10	KN
Silver	ND	1	0.5	mg/Kg	08/06/10	KN
Thallium	ND	1	1.0	mg/Kg	08/06/10	KN
Vanadium	83.9	1	0.5	mg/Kg	08/06/10	KN
Zinc	100.0	1	5.0	mg/Kg	08/06/10	KN

**7471A Mercury in Solid/Wipe**

Mercury	ND	1	0.14	mg/Kg	08/06/10	NF
---------	----	---	------	-------	----------	----

**8015 TEPH Diesel**

TEPH Diesel	1.0	1	1.0	mg/Kg	08/06/10	AF
-------------	-----	---	-----	-------	----------	----

**Surrogates**

				Units	Control Limits
Triacontane (Sur)	61			%	60 - 140

**8081A - Organochlorine Pesticides by GC**

4,4-DDD	ND	1	0.005	mg/Kg	08/06/10	GH
4,4-DDE	ND	1	0.004	mg/Kg	08/06/10	GH
4,4-DDT	ND	1	0.005	mg/Kg	08/06/10	GH
Aldrin	ND	1	0.004	mg/Kg	08/06/10	GH
Alpha BHC	ND	1	0.002	mg/Kg	08/06/10	GH
Beta BHC	ND	1	0.003	mg/Kg	08/06/10	GH
Chlordane	ND	1	0.025	mg/Kg	08/06/10	GH

DLR = Detection limit for reporting purposes, ND = Not Detected below indicated detection limit, DF = Dilution Factor

**ASSOCIATED LABORATORIES**

Analytical Results Report



Order #: 1100712

Client: American Geotechnical

Matrix: SOLID

Client Sample ID: Drum # 3

Date Sampled: 08/03/2010

Time Sampled: 13:10

Sampled By:

Analyte	Result	DF	DLR	Units	Date/Analyst
---------	--------	----	-----	-------	--------------

**8081A - Organochlorine Pesticides by GC**

Delta BHC	ND	1	0.005	mg/Kg	08/06/10 GH
Dieldrin	ND	1	0.003	mg/Kg	08/06/10 GH
Endosulfan I	ND	1	0.004	mg/Kg	08/06/10 GH
Endosulfan II	ND	1	0.004	mg/Kg	08/06/10 GH
Endosulfan sulfate	ND	1	0.004	mg/Kg	08/06/10 GH
Endrin	ND	1	0.004	mg/Kg	08/06/10 GH
Endrin aldehyde	ND	1	0.004	mg/Kg	08/06/10 GH
Endrin Ketone	ND	1	0.005	mg/Kg	08/06/10 GH
Heptachlor	ND	1	0.004	mg/Kg	08/06/10 GH
Heptachlor epoxide	ND	1	0.003	mg/Kg	08/06/10 GH
Lindane	ND	1	0.003	mg/Kg	08/06/10 GH
Methoxychlor	ND	1	0.025	mg/Kg	08/06/10 GH
Toxaphene	ND	1	0.250	mg/Kg	08/06/10 GH

**Surrogates**

				Units	Control Limits
DCB(Sur2)	102			%	55 - 135
TCMX (Sur1)	105			%	50 - 125

**8260B Volatile Organic Compounds**

1,1,1,2-Tetrachloroethane	ND	1	5	ug/Kg	08/06/10 NZ
1,1,1-Trichloroethane	ND	1	5	ug/Kg	08/06/10 NZ
1,1,2,2-Tetrachloroethane	ND	1	5	ug/Kg	08/06/10 NZ
1,1,2-Trichloroethane	ND	1	5	ug/Kg	08/06/10 NZ
1,1,2-Trichlorotrifluoroethane	ND	1	5	ug/Kg	08/06/10 NZ
1,1-Dichloroethane	ND	1	5	ug/Kg	08/06/10 NZ
1,1-Dichloroethene	ND	1	5	ug/Kg	08/06/10 NZ
1,1-Dichloropropene	ND	1	5	ug/Kg	08/06/10 NZ
1,2,3-Trichlorobenzene	ND	1	5	ug/Kg	08/06/10 NZ
1,2,3-Trichloropropane	ND	1	5	ug/Kg	08/06/10 NZ
1,2,4-Trichlorobenzene	ND	1	5	ug/Kg	08/06/10 NZ
1,2,4-Trimethylbenzene	ND	1	5	ug/Kg	08/06/10 NZ
1,2-Dibromo-3-chloropropane	ND	1	5	ug/Kg	08/06/10 NZ
1,2-Dibromoethane	ND	1	5	ug/Kg	08/06/10 NZ
1,2-Dichlorobenzene	ND	1	5	ug/Kg	08/06/10 NZ
1,2-Dichloroethane	ND	1	5	ug/Kg	08/06/10 NZ
1,2-Dichloropropane	ND	1	5	ug/Kg	08/06/10 NZ
1,3,5-Trimethylbenzene	ND	1	5	ug/Kg	08/06/10 NZ
1,3-Dichlorobenzene	ND	1	5	ug/Kg	08/06/10 NZ

DLR = Detection limit for reporting purposes, ND = Not Detected below indicated detection limit, DF = Dilution Factor

**ASSOCIATED LABORATORIES**

Analytical Results Report



Order #: 1100712

Client: American Geotechnical

Matrix: SOLID

Client Sample ID: Drum # 3

Date Sampled: 08/03/2010

Time Sampled: 13:10

Sampled By:

Analyte	Result	DF	DLR	Units	Date/Analyst
<b>8260B Volatile Organic Compounds</b>					
1,3-Dichloropropane	ND	1	5	ug/Kg	08/06/10 NZ
1,4-Dichlorobenzene	ND	1	5	ug/Kg	08/06/10 NZ
2,2-Dichloropropane	ND	1	5	ug/Kg	08/06/10 NZ
2-Butanone (MEK)	ND	1	100	ug/Kg	08/06/10 NZ
2-Chloroethyl vinyl ether	ND	1	5	ug/Kg	08/06/10 NZ
2-Chlorotoluene	ND	1	5	ug/Kg	08/06/10 NZ
4-Chlorotoluene	ND	1	5	ug/Kg	08/06/10 NZ
4-Methyl -2- Pentanone (MIBK)	ND	1	5	ug/Kg	08/06/10 NZ
Acetone	ND	1	50	ug/Kg	08/06/10 NZ
Allyl chloride	ND	1	5	ug/Kg	08/06/10 NZ
Benzene	ND	1	5	ug/Kg	08/06/10 NZ
Bromobenzene	ND	1	5	ug/Kg	08/06/10 NZ
Bromochloromethane	ND	1	5	ug/Kg	08/06/10 NZ
Bromodichloromethane	ND	1	5	ug/Kg	08/06/10 NZ
Bromoform	ND	1	5	ug/Kg	08/06/10 NZ
Bromomethane	ND	1	5	ug/Kg	08/06/10 NZ
Carbon tetrachloride	ND	1	5	ug/Kg	08/06/10 NZ
Chlorobenzene	ND	1	5	ug/Kg	08/06/10 NZ
Chloroethane	ND	1	5	ug/Kg	08/06/10 NZ
Chloroform	ND	1	5	ug/Kg	08/06/10 NZ
Chloromethane	ND	1	5	ug/Kg	08/06/10 NZ
cis-1,2-Dichloroethene	ND	1	5	ug/Kg	08/06/10 NZ
cis-1,3-Dichloropropene	ND	1	5	ug/Kg	08/06/10 NZ
cis-1,4-Dichloro-2-butene	ND	1	5	ug/Kg	08/06/10 NZ
Dibromochloromethane	ND	1	5	ug/Kg	08/06/10 NZ
Dibromomethane	ND	1	5	ug/Kg	08/06/10 NZ
Dichlorodifluoromethane	ND	1	5	ug/Kg	08/06/10 NZ
Ethyl benzene	ND	1	5	ug/Kg	08/06/10 NZ
Hexachlorobutadiene	ND	1	5	ug/Kg	08/06/10 NZ
Isopropylbenzene (Cumene)	ND	1	5	ug/Kg	08/06/10 NZ
m and p-Xylene	ND	1	5	ug/Kg	08/06/10 NZ
Methyl-tert-butylether (MTBE)	ND	1	5	ug/Kg	08/06/10 NZ
Methylene chloride	ND	1	5	ug/Kg	08/06/10 NZ
n-Butylbenzene	ND	1	5	ug/Kg	08/06/10 NZ
n-Propylbenzene	ND	1	5	ug/Kg	08/06/10 NZ
Naphthalene	ND	1	5	ug/Kg	08/06/10 NZ
o-Xylene	ND	1	5	ug/Kg	08/06/10 NZ
p-Isopropyltoluene	ND	1	5	ug/Kg	08/06/10 NZ
sec-Butylbenzene	ND	1	5	ug/Kg	08/06/10 NZ

DLR = Detection limit for reporting purposes, ND = Not Detected below indicated detection limit, DF = Dilution Factor

**ASSOCIATED LABORATORIES**

Analytical Results Report



Order #: 1100712

Client: American Geotechnical

Matrix: SOLID

Client Sample ID: Drum # 3

Date Sampled: 08/03/2010

Time Sampled: 13:10

Sampled By:

Analyte	Result	DF	DLR	Units	Date/Analyst
---------	--------	----	-----	-------	--------------

**8260B Volatile Organic Compounds**

Styrene	ND	1	5	ug/Kg	08/06/10 NZ
tert-Butylbenzene	ND	1	5	ug/Kg	08/06/10 NZ
Tetrachloroethene	ND	1	5	ug/Kg	08/06/10 NZ
Toluene	ND	1	5	ug/Kg	08/06/10 NZ
trans-1,2-Dichloroethene	ND	1	5	ug/Kg	08/06/10 NZ
trans-1,3-Dichloropropene	ND	1	5	ug/Kg	08/06/10 NZ
trans-1,4-Dichloro-2-butene	ND	1	5	ug/Kg	08/06/10 NZ
Trichloroethene	ND	1	5	ug/Kg	08/06/10 NZ
Trichlorofluoromethane	ND	1	5	ug/Kg	08/06/10 NZ
Vinyl chloride	ND	1	5	ug/Kg	08/06/10 NZ
Xylenes, total	ND	1	5	ug/Kg	08/06/10 NZ
Di-isopropyl ether (DIPE)	ND	1	2.0	ug/Kg	08/06/10 NZ
Ethyl-tertbutylether (ETBE)	ND	1	2.0	ug/Kg	08/06/10 NZ
Tert-amylmethylether (TAME)	ND	1	2.0	ug/Kg	08/06/10 NZ
Tertiary butyl alcohol (TBA)	ND	1	10	ug/Kg	08/06/10 NZ

**Surrogates**

				Units	Control Limits
Surr1 - Dibromofluoromethane	107			%	70 - 135
Surr2 - 1,2-Dichloroethane-d4	109			%	70 - 135
Surr3 - Toluene-d8	102			%	70 - 135
Surr4 - p-Bromofluorobenzene	101			%	70 - 135

**8270C Acid/Base/Neutral Extractables**

1,2,4-Trichlorobenzene	ND	1	300	ug/Kg	08/09/10 SD
1,2-Dichlorobenzene	ND	1	300	ug/Kg	08/09/10 SD
1,3-Dichlorobenzene	ND	1	300	ug/Kg	08/09/10 SD
1,4-Dichlorobenzene	ND	1	300	ug/Kg	08/09/10 SD
2,4,5-Trichlorophenol	ND	1	300	ug/Kg	08/09/10 SD
2,4,6-Trichlorophenol	ND	1	300	ug/Kg	08/09/10 SD
2,4-Dichlorophenol	ND	1	300	ug/Kg	08/09/10 SD
2,4-Dimethylphenol	ND	1	300	ug/Kg	08/09/10 SD
2,4-Dinitrophenol	ND	1	300	ug/Kg	08/09/10 SD
2,4-Dinitrotoluene	ND	1	300	ug/Kg	08/09/10 SD
2,6-Dinitrotoluene	ND	1	300	ug/Kg	08/09/10 SD
2-Chloronaphthalene	ND	1	300	ug/Kg	08/09/10 SD
2-Chlorophenol	ND	1	300	ug/Kg	08/09/10 SD
2-Methylnaphthalene	ND	1	300	ug/Kg	08/09/10 SD
2-Methylphenol	ND	1	300	ug/Kg	08/09/10 SD

DLR = Detection limit for reporting purposes, ND = Not Detected below indicated detection limit, DF = Dilution Factor

**ASSOCIATED LABORATORIES**

Analytical Results Report



Order #: 1100712

Client: American Geotechnical

Matrix: SOLID

Client Sample ID: Drum # 3

Date Sampled: 08/03/2010

Time Sampled: 13:10

Sampled By:

Analyte	Result	DF	DLR	Units	Date/Analyst
<b>8270C Acid/Base/Neutral Extractables</b>					
2-Nitroaniline	ND	1	300	ug/Kg	08/09/10 SD
2-Nitrophenol	ND	1	300	ug/Kg	08/09/10 SD
3,3-Dichlorobenzidine	ND	1	300	ug/Kg	08/09/10 SD
3-Methylphenol	ND	1	500	ug/Kg	08/09/10 SD
3-Nitroaniline	ND	1	300	ug/Kg	08/09/10 SD
4,6-Dinitro-2-methylphenol	ND	1	300	ug/Kg	08/09/10 SD
4-Bromophenyl-phenylether	ND	1	300	ug/Kg	08/09/10 SD
4-Chloro-3-methylphenol	ND	1	300	ug/Kg	08/09/10 SD
4-Chloroaniline	ND	1	300	ug/Kg	08/09/10 SD
4-Chlorophenyl-phenylether	ND	1	300	ug/Kg	08/09/10 SD
4-Methylphenol	ND	1	500	ug/Kg	08/09/10 SD
4-Nitroaniline	ND	1	300	ug/Kg	08/09/10 SD
4-Nitrophenol	ND	1	300	ug/Kg	08/09/10 SD
Acenaphthene	ND	1	300	ug/Kg	08/09/10 SD
Acenaphthylene	ND	1	300	ug/Kg	08/09/10 SD
Anthracene	ND	1	300	ug/Kg	08/09/10 SD
Benzidine	ND	1	1500	ug/Kg	08/09/10 SD
Benzo(a)anthracene	ND	1	300	ug/Kg	08/09/10 SD
Benzo(a)pyrene	ND	1	300	ug/Kg	08/09/10 SD
Benzo(b)fluoranthene	ND	1	300	ug/Kg	08/09/10 SD
Benzo(g,h,i)perylene	ND	1	300	ug/Kg	08/09/10 SD
Benzo(k)fluoranthene	ND	1	300	ug/Kg	08/09/10 SD
Benzoic Acid	ND	1	300	ug/Kg	08/09/10 SD
Benzyl alcohol	ND	1	300	ug/Kg	08/09/10 SD
bis(2-Chloroethoxy)methane	ND	1	300	ug/Kg	08/09/10 SD
bis(2-Chloroethyl)ether	ND	1	300	ug/Kg	08/09/10 SD
bis(2-Chloroisopropyl) ether	ND	1	300	ug/Kg	08/09/10 SD
bis(2-Ethylhexyl)phthalate	ND	1	300	ug/Kg	08/09/10 SD
Butylbenzylphthalate	ND	1	300	ug/Kg	08/09/10 SD
Chrysene	ND	1	300	ug/Kg	08/09/10 SD
Di-n-butylphthalate	ND	1	300	ug/Kg	08/09/10 SD
Di-n-octylphthalate	ND	1	300	ug/Kg	08/09/10 SD
Dibenz(a,h)anthracene	ND	1	300	ug/Kg	08/09/10 SD
Dibenzofuran	ND	1	300	ug/Kg	08/09/10 SD
Diethylphthalate	ND	1	300	ug/Kg	08/09/10 SD
Dimethylphthalate	ND	1	300	ug/Kg	08/09/10 SD
Fluoranthene	ND	1	300	ug/Kg	08/09/10 SD
Fluorene	ND	1	300	ug/Kg	08/09/10 SD
Hexachlorobenzene	ND	1	300	ug/Kg	08/09/10 SD

DLR = Detection limit for reporting purposes, ND = Not Detected below indicated detection limit, DF = Dilution Factor

**ASSOCIATED LABORATORIES**

Analytical Results Report





Order #: 1100712

Client: American Geotechnical

Matrix: SOLID

Client Sample ID: Drum # 3

Date Sampled: 08/03/2010

Time Sampled: 13:10

Sampled By:

Analyte	Result	DF	DLR	Units	Date/Analyst
---------	--------	----	-----	-------	--------------

**8270C Acid/Base/Neutral Extractables**

Hexachlorobutadiene	ND	1	300	ug/Kg	08/09/10 SD
Hexachlorocyclopentadiene	ND	1	300	ug/Kg	08/09/10 SD
Hexachloroethane	ND	1	300	ug/Kg	08/09/10 SD
Indeno(1,2,3-c,d)pyrene	ND	1	300	ug/Kg	08/09/10 SD
Isophorone	ND	1	300	ug/Kg	08/09/10 SD
N-Nitroso-di-n-propylamine	ND	1	300	ug/Kg	08/09/10 SD
N-Nitrosodiphenylamine	ND	1	300	ug/Kg	08/09/10 SD
Naphthalene	ND	1	300	ug/Kg	08/09/10 SD
Nitrobenzene	ND	1	300	ug/Kg	08/09/10 SD
Pentachlorophenol	ND	1	300	ug/Kg	08/09/10 SD
Phenanthrene	ND	1	300	ug/Kg	08/09/10 SD
Phenol	ND	1	300	ug/Kg	08/09/10 SD
Pyrene	ND	1	300	ug/Kg	08/09/10 SD

**Surrogates**

				Units	Control Limits
2,4,6-Tribromophenol (sur)	65			%	17 - 122
2-Fluorobiphenyl (sur)	69			%	30 - 115
2-Fluorophenol (sur)	66			%	25 - 121
Nitrobenzene-d5 (sur)	56			%	23 - 120
Phenol-d5 (sur)	63			%	24 - 113
Terphenyl-d14 (sur)	91			%	18 - 137

**8015B - Gasoline**

Gasoline	ND	1	3	mg/Kg	08/06/10 LT
----------	----	---	---	-------	-------------

**Surrogates**

				Units	Control Limits
p-Bromofluorobenzene (Sur)	133			%	60 - 140

DLR = Detection limit for reporting purposes, ND = Not Detected below indicated detection limit, DF = Dilution Factor

**ASSOCIATED LABORATORIES**

Analytical Results Report



Order #: 1100713

Client: American Geotechnical

Matrix: SOLID

Client Sample ID: Drum # 4

Date Sampled: 08/03/2010

Time Sampled: 15:40

Sampled By:

Analyte	Result	DF	DLR	Units	Date/Analyst
---------	--------	----	-----	-------	--------------

**6010B ICP CAM Metals Only (W/S/W)**

Antimony	ND	1	3.0	mg/Kg	08/06/10	KN
Arsenic	7.19	1	1.0	mg/Kg	08/06/10	KN
Barium	385	1	1.0	mg/Kg	08/06/10	KN
Beryllium	0.589	1	0.5	mg/Kg	08/06/10	KN
Cadmium	1.01	1	0.5	mg/Kg	08/06/10	KN
Chromium	52.3	1	1.0	mg/Kg	08/06/10	KN
Cobalt	6.90	1	0.5	mg/Kg	08/06/10	KN
Copper	42.7	1	1.0	mg/Kg	08/06/10	KN
Lead	12.5	1	0.5	mg/Kg	08/06/10	KN
Molybdenum	6.25	1	1.0	mg/Kg	08/06/10	KN
Nickel	31.7	1	1.5	mg/Kg	08/06/10	KN
Selenium	2.15	1	1.0	mg/Kg	08/06/10	KN
Silver	ND	1	0.5	mg/Kg	08/06/10	KN
Thallium	ND	1	1.0	mg/Kg	08/06/10	KN
Vanadium	57.1	1	0.5	mg/Kg	08/06/10	KN
Zinc	78.0	1	5.0	mg/Kg	08/06/10	KN

**7471A Mercury in Solid/Wipe**

Mercury	ND	1	0.14	mg/Kg	08/06/10	NF
---------	----	---	------	-------	----------	----

**8015 TEPH Diesel**

TEPH Diesel	5.0	5	5.0	mg/Kg	08/09/10	AF
-------------	-----	---	-----	-------	----------	----

**Surrogates**

				Units	Control Limits
Triacotane (Sur)	91			%	60 - 140

**8081A - Organochlorine Pesticides by GC**

4,4-DDD	ND	1	0.005	mg/Kg	08/06/10	GH
4,4-DDE	ND	1	0.004	mg/Kg	08/06/10	GH
4,4-DDT	ND	1	0.005	mg/Kg	08/06/10	GH
Aldrin	ND	1	0.004	mg/Kg	08/06/10	GH
Alpha BHC	ND	1	0.002	mg/Kg	08/06/10	GH
Beta BHC	ND	1	0.003	mg/Kg	08/06/10	GH
Chlordane	ND	1	0.025	mg/Kg	08/06/10	GH

DLR = Detection limit for reporting purposes, ND = Not Detected below indicated detection limit, DF = Dilution Factor

**ASSOCIATED LABORATORIES**

Analytical Results Report



Order #: 1100713

Client: American Geotechnical

Matrix: SOLID

Client Sample ID: Drum # 4

Date Sampled: 08/03/2010

Time Sampled: 15:40

Sampled By:

Analyte	Result	DF	DLR	Units	Date/Analyst
<b>8081A - Organochlorine Pesticides by GC</b>					
Delta BHC	ND	1	0.005	mg/Kg	08/06/10 GH
Dieldrin	ND	1	0.003	mg/Kg	08/06/10 GH
Endosulfan I	ND	1	0.004	mg/Kg	08/06/10 GH
Endosulfan II	ND	1	0.004	mg/Kg	08/06/10 GH
Endosulfan sulfate	ND	1	0.004	mg/Kg	08/06/10 GH
Endrin	ND	1	0.004	mg/Kg	08/06/10 GH
Endrin aldehyde	ND	1	0.004	mg/Kg	08/06/10 GH
Endrin Ketone	ND	1	0.005	mg/Kg	08/06/10 GH
Heptachlor	ND	1	0.004	mg/Kg	08/06/10 GH
Heptachlor epoxide	ND	1	0.003	mg/Kg	08/06/10 GH
Lindane	ND	1	0.003	mg/Kg	08/06/10 GH
Methoxychlor	ND	1	0.025	mg/Kg	08/06/10 GH
Toxaphene	ND	1	0.250	mg/Kg	08/06/10 GH
<b>Surrogates</b>				<b>Units</b>	<b>Control Limits</b>
DCB(Sur2)	66			%	55 - 135
TCMX (Sur1)	87			%	50 - 125

**8260B Volatile Organic Compounds**

1,1,1,2-Tetrachloroethane	ND	1	5	ug/Kg	08/07/10 NZ
1,1,1-Trichloroethane	ND	1	5	ug/Kg	08/07/10 NZ
1,1,2,2-Tetrachloroethane	ND	1	5	ug/Kg	08/07/10 NZ
1,1,2-Trichloroethane	ND	1	5	ug/Kg	08/07/10 NZ
1,1,2-Trichlorotrifluoroethane	ND	1	5	ug/Kg	08/07/10 NZ
1,1-Dichloroethane	ND	1	5	ug/Kg	08/07/10 NZ
1,1-Dichloroethene	ND	1	5	ug/Kg	08/07/10 NZ
1,1-Dichloropropene	ND	1	5	ug/Kg	08/07/10 NZ
1,2,3-Trichlorobenzene	ND	1	5	ug/Kg	08/07/10 NZ
1,2,3-Trichloropropane	ND	1	5	ug/Kg	08/07/10 NZ
1,2,4-Trichlorobenzene	ND	1	5	ug/Kg	08/07/10 NZ
1,2,4-Trimethylbenzene	ND	1	5	ug/Kg	08/07/10 NZ
1,2-Dibromo-3-chloropropane	ND	1	5	ug/Kg	08/07/10 NZ
1,2-Dibromoethane	ND	1	5	ug/Kg	08/07/10 NZ
1,2-Dichlorobenzene	ND	1	5	ug/Kg	08/07/10 NZ
1,2-Dichloroethane	ND	1	5	ug/Kg	08/07/10 NZ
1,2-Dichloropropane	ND	1	5	ug/Kg	08/07/10 NZ
1,3,5-Trimethylbenzene	ND	1	5	ug/Kg	08/07/10 NZ
1,3-Dichlorobenzene	ND	1	5	ug/Kg	08/07/10 NZ

DLR = Detection limit for reporting purposes, ND = Not Detected below indicated detection limit, DF = Dilution Factor

**ASSOCIATED LABORATORIES**

Analytical Results Report



Order #: 1100713

Client: American Geotechnical

Matrix: SOLID

Client Sample ID: Drum # 4

Date Sampled: 08/03/2010

Time Sampled: 15:40

Sampled By:

Analyte	Result	DF	DLR	Units	Date/Analyst
<b>8260B Volatile Organic Compounds</b>					
1,3-Dichloropropane	ND	1	5	ug/Kg	08/07/10 NZ
1,4-Dichlorobenzene	ND	1	5	ug/Kg	08/07/10 NZ
2,2-Dichloropropane	ND	1	5	ug/Kg	08/07/10 NZ
2-Butanone (MEK)	ND	1	100	ug/Kg	08/07/10 NZ
2-Chloroethyl vinyl ether	ND	1	5	ug/Kg	08/07/10 NZ
2-Chlorotoluene	ND	1	5	ug/Kg	08/07/10 NZ
4-Chlorotoluene	ND	1	5	ug/Kg	08/07/10 NZ
4-Methyl -2- Pentanone (MIBK)	ND	1	5	ug/Kg	08/07/10 NZ
Acetone	ND	1	50	ug/Kg	08/07/10 NZ
Allyl chloride	ND	1	5	ug/Kg	08/07/10 NZ
Benzene	ND	1	5	ug/Kg	08/07/10 NZ
Bromobenzene	ND	1	5	ug/Kg	08/07/10 NZ
Bromochloromethane	ND	1	5	ug/Kg	08/07/10 NZ
Bromodichloromethane	ND	1	5	ug/Kg	08/07/10 NZ
Bromoform	ND	1	5	ug/Kg	08/07/10 NZ
Bromomethane	ND	1	5	ug/Kg	08/07/10 NZ
Carbon tetrachloride	ND	1	5	ug/Kg	08/07/10 NZ
Chlorobenzene	ND	1	5	ug/Kg	08/07/10 NZ
Chloroethane	ND	1	5	ug/Kg	08/07/10 NZ
Chloroform	ND	1	5	ug/Kg	08/07/10 NZ
Chloromethane	ND	1	5	ug/Kg	08/07/10 NZ
cis-1,2-Dichloroethene	ND	1	5	ug/Kg	08/07/10 NZ
cis-1,3-Dichloropropene	ND	1	5	ug/Kg	08/07/10 NZ
cis-1,4-Dichloro-2-butene	ND	1	5	ug/Kg	08/07/10 NZ
Dibromochloromethane	ND	1	5	ug/Kg	08/07/10 NZ
Dibromomethane	ND	1	5	ug/Kg	08/07/10 NZ
Dichlorodifluoromethane	ND	1	5	ug/Kg	08/07/10 NZ
Ethyl benzene	ND	1	5	ug/Kg	08/07/10 NZ
Hexachlorobutadiene	ND	1	5	ug/Kg	08/07/10 NZ
Isopropylbenzene (Cumene)	ND	1	5	ug/Kg	08/07/10 NZ
m and p-Xylene	ND	1	5	ug/Kg	08/07/10 NZ
Methyl-tert-butylether (MTBE)	ND	1	5	ug/Kg	08/07/10 NZ
Methylene chloride	ND	1	5	ug/Kg	08/07/10 NZ
n-Butylbenzene	ND	1	5	ug/Kg	08/07/10 NZ
n-Propylbenzene	ND	1	5	ug/Kg	08/07/10 NZ
Naphthalene	ND	1	5	ug/Kg	08/07/10 NZ
o-Xylene	ND	1	5	ug/Kg	08/07/10 NZ
p-Isopropyltoluene	ND	1	5	ug/Kg	08/07/10 NZ
sec-Butylbenzene	ND	1	5	ug/Kg	08/07/10 NZ

DLR = Detection limit for reporting purposes, ND = Not Detected below indicated detection limit, DF = Dilution Factor

**ASSOCIATED LABORATORIES**

Analytical Results Report



Order #: 1100713

Client: American Geotechnical

Matrix: SOLID

Client Sample ID: Drum # 4

Date Sampled: 08/03/2010

Time Sampled: 15:40

Sampled By:

Analyte	Result	DF	DLR	Units	Date/Analyst
---------	--------	----	-----	-------	--------------

**8260B Volatile Organic Compounds**

Styrene	ND	1	5	ug/Kg	08/07/10 NZ
tert-Butylbenzene	ND	1	5	ug/Kg	08/07/10 NZ
Tetrachloroethene	ND	1	5	ug/Kg	08/07/10 NZ
Toluene	ND	1	5	ug/Kg	08/07/10 NZ
trans-1,2-Dichloroethene	ND	1	5	ug/Kg	08/07/10 NZ
trans-1,3-Dichloropropene	ND	1	5	ug/Kg	08/07/10 NZ
trans-1,4-Dichloro-2-butene	ND	1	5	ug/Kg	08/07/10 NZ
Trichloroethene	ND	1	5	ug/Kg	08/07/10 NZ
Trichlorofluoromethane	ND	1	5	ug/Kg	08/07/10 NZ
Vinyl chloride	ND	1	5	ug/Kg	08/07/10 NZ
Xylenes, total	ND	1	5	ug/Kg	08/07/10 NZ
Di-isopropyl ether (DIPE)	ND	1	2.0	ug/Kg	08/07/10 NZ
Ethyl-tertbutylether (ETBE)	ND	1	2.0	ug/Kg	08/07/10 NZ
Tert-amylmethylether (TAME)	ND	1	2.0	ug/Kg	08/07/10 NZ
Tertiary butyl alcohol (TBA)	ND	1	10	ug/Kg	08/07/10 NZ

**Surrogates**

				Units	Control Limits
Surr1 - Dibromofluoromethane	103			%	70 - 135
Surr2 - 1,2-Dichloroethane-d4	121			%	70 - 135
Surr3 - Toluene-d8	105			%	70 - 135
Surr4 - p-Bromofluorobenzene	98			%	70 - 135

**8270C Acid/Base/Neutral Extractables**

1,2,4-Trichlorobenzene	ND	1	300	ug/Kg	08/09/10 SD
1,2-Dichlorobenzene	ND	1	300	ug/Kg	08/09/10 SD
1,3-Dichlorobenzene	ND	1	300	ug/Kg	08/09/10 SD
1,4-Dichlorobenzene	ND	1	300	ug/Kg	08/09/10 SD
2,4,5-Trichlorophenol	ND	1	300	ug/Kg	08/09/10 SD
2,4,6-Trichlorophenol	ND	1	300	ug/Kg	08/09/10 SD
2,4-Dichlorophenol	ND	1	300	ug/Kg	08/09/10 SD
2,4-Dimethylphenol	ND	1	300	ug/Kg	08/09/10 SD
2,4-Dinitrophenol	ND	1	300	ug/Kg	08/09/10 SD
2,4-Dinitrotoluene	ND	1	300	ug/Kg	08/09/10 SD
2,6-Dinitrotoluene	ND	1	300	ug/Kg	08/09/10 SD
2-Chloronaphthalene	ND	1	300	ug/Kg	08/09/10 SD
2-Chlorophenol	ND	1	300	ug/Kg	08/09/10 SD
2-Methylnaphthalene	ND	1	300	ug/Kg	08/09/10 SD
2-Methylphenol	ND	1	300	ug/Kg	08/09/10 SD

DLR = Detection limit for reporting purposes, ND = Not Detected below indicated detection limit, DF = Dilution Factor

**ASSOCIATED LABORATORIES**

Analytical Results Report



Order #: 1100713

Client: American Geotechnical

Matrix: SOLID

Client Sample ID: Drum # 4

Date Sampled: 08/03/2010

Time Sampled: 15:40

Sampled By:

Analyte	Result	DF	DLR	Units	Date/Analyst
<b>8270C Acid/Base/Neutral Extractables</b>					
2-Nitroaniline	ND	1	300	ug/Kg	08/09/10 SD
2-Nitrophenol	ND	1	300	ug/Kg	08/09/10 SD
3,3-Dichlorobenzidine	ND	1	300	ug/Kg	08/09/10 SD
3-Methylphenol	ND	1	500	ug/Kg	08/09/10 SD
3-Nitroaniline	ND	1	300	ug/Kg	08/09/10 SD
4,6-Dinitro-2-methylphenol	ND	1	300	ug/Kg	08/09/10 SD
4-Bromophenyl-phenylether	ND	1	300	ug/Kg	08/09/10 SD
4-Chloro-3-methylphenol	ND	1	300	ug/Kg	08/09/10 SD
4-Chloroaniline	ND	1	300	ug/Kg	08/09/10 SD
4-Chlorophenyl-phenylether	ND	1	300	ug/Kg	08/09/10 SD
4-Methylphenol	ND	1	500	ug/Kg	08/09/10 SD
4-Nitroaniline	ND	1	300	ug/Kg	08/09/10 SD
4-Nitrophenol	ND	1	300	ug/Kg	08/09/10 SD
Acenaphthene	ND	1	300	ug/Kg	08/09/10 SD
Acenaphthylene	ND	1	300	ug/Kg	08/09/10 SD
Anthracene	ND	1	300	ug/Kg	08/09/10 SD
Benzidine	ND	1	1500	ug/Kg	08/09/10 SD
Benzo(a)anthracene	ND	1	300	ug/Kg	08/09/10 SD
Benzo(a)pyrene	ND	1	300	ug/Kg	08/09/10 SD
Benzo(b)fluoranthene	ND	1	300	ug/Kg	08/09/10 SD
Benzo(g,h,i)perylene	ND	1	300	ug/Kg	08/09/10 SD
Benzo(k)fluoranthene	ND	1	300	ug/Kg	08/09/10 SD
Benzoic Acid	ND	1	300	ug/Kg	08/09/10 SD
Benzyl alcohol	ND	1	300	ug/Kg	08/09/10 SD
bis(2-Chloroethoxy)methane	ND	1	300	ug/Kg	08/09/10 SD
bis(2-Chloroethyl)ether	ND	1	300	ug/Kg	08/09/10 SD
bis(2-Chloroisopropyl) ether	ND	1	300	ug/Kg	08/09/10 SD
bis(2-Ethylhexyl)phthalate	ND	1	300	ug/Kg	08/09/10 SD
Butylbenzylphthalate	ND	1	300	ug/Kg	08/09/10 SD
Chrysene	ND	1	300	ug/Kg	08/09/10 SD
Di-n-butylphthalate	ND	1	300	ug/Kg	08/09/10 SD
Di-n-octylphthalate	ND	1	300	ug/Kg	08/09/10 SD
Dibenz(a,h)anthracene	ND	1	300	ug/Kg	08/09/10 SD
Dibenzofuran	ND	1	300	ug/Kg	08/09/10 SD
Diethylphthalate	ND	1	300	ug/Kg	08/09/10 SD
Dimethylphthalate	ND	1	300	ug/Kg	08/09/10 SD
Fluoranthene	ND	1	300	ug/Kg	08/09/10 SD
Fluorene	ND	1	300	ug/Kg	08/09/10 SD
Hexachlorobenzene	ND	1	300	ug/Kg	08/09/10 SD

DLR = Detection limit for reporting purposes, ND = Not Detected below indicated detection limit, DF = Dilution Factor

**ASSOCIATED LABORATORIES**

Analytical Results Report



Order #: 1100713

Client: American Geotechnical

Matrix: SOLID

Client Sample ID: Drum # 4

Date Sampled: 08/03/2010

Time Sampled: 15:40

Sampled By:

Analyte	Result	DF	DLR	Units	Date/Analyst
---------	--------	----	-----	-------	--------------

**8270C Acid/Base/Neutral Extractables**

Hexachlorobutadiene	ND	1	300	ug/Kg	08/09/10 SD
Hexachlorocyclopentadiene	ND	1	300	ug/Kg	08/09/10 SD
Hexachloroethane	ND	1	300	ug/Kg	08/09/10 SD
Indeno(1,2,3-c,d)pyrene	ND	1	300	ug/Kg	08/09/10 SD
Isophorone	ND	1	300	ug/Kg	08/09/10 SD
N-Nitroso-di-n-propylamine	ND	1	300	ug/Kg	08/09/10 SD
N-Nitrosodiphenylamine	ND	1	300	ug/Kg	08/09/10 SD
Naphthalene	ND	1	300	ug/Kg	08/09/10 SD
Nitrobenzene	ND	1	300	ug/Kg	08/09/10 SD
Pentachlorophenol	ND	1	300	ug/Kg	08/09/10 SD
Phenanthrene	ND	1	300	ug/Kg	08/09/10 SD
Phenol	ND	1	300	ug/Kg	08/09/10 SD
Pyrene	ND	1	300	ug/Kg	08/09/10 SD

**Surrogates**

				Units	Control Limits
2,4,6-Tribromophenol (sur)	70			%	17 - 122
2-Fluorobiphenyl (sur)	83			%	30 - 115
2-Fluorophenol (sur)	82			%	25 - 121
Nitrobenzene-d5 (sur)	69			%	23 - 120
Phenol-d5 (sur)	81			%	24 - 113
Terphenyl-d14 (sur)	88			%	18 - 137

**8015B - Gasoline**

Gasoline	ND	1	3	mg/Kg	08/06/10 LT
----------	----	---	---	-------	-------------

**Surrogates**

				Units	Control Limits
p-Bromofluorobenzene (Sur)	134			%	60 - 140

DLR = Detection limit for reporting purposes, ND = Not Detected below indicated detection limit, DF = Dilution Factor

**ASSOCIATED LABORATORIES**

Analytical Results Report



Order #: 1100714

Client: American Geotechnical

Matrix: SOLID

Client Sample ID: Drum # 5

Date Sampled: 08/03/2010

Time Sampled: 14:40

Sampled By:

Analyte	Result	DF	DLR	Units	Date/Analyst
---------	--------	----	-----	-------	--------------

**6010B ICP CAM Metals Only (W/S/W)**

Antimony	ND	1	3.0	mg/Kg	08/06/10 KN
Arsenic	5.33	1	1.0	mg/Kg	08/06/10 KN
Barium	1110	1	1.0	mg/Kg	08/06/10 KN
Beryllium	0.596	1	0.5	mg/Kg	08/06/10 KN
Cadmium	4.50	1	0.5	mg/Kg	08/06/10 KN
Chromium	112	1	1.0	mg/Kg	08/06/10 KN
Cobalt	6.50	1	0.5	mg/Kg	08/06/10 KN
Copper	67.6	1	1.0	mg/Kg	08/06/10 KN
Lead	4.57	1	0.5	mg/Kg	08/06/10 KN
Molybdenum	5.63	1	1.0	mg/Kg	08/06/10 KN
Nickel	158	1	1.5	mg/Kg	08/06/10 KN
Selenium	3.66	1	1.0	mg/Kg	08/06/10 KN
Silver	0.544	1	0.5	mg/Kg	08/06/10 KN
Thallium	2.11	1	1.0	mg/Kg	08/06/10 KN
Vanadium	257	1	0.5	mg/Kg	08/06/10 KN
Zinc	157	1	5.0	mg/Kg	08/06/10 KN

**7471A Mercury in Solid/Wipe**

Mercury	ND	1	0.14	mg/Kg	08/06/10 NF
---------	----	---	------	-------	-------------

**8015 TEPH Diesel**

TEPH Diesel	1.0	1	1.0	mg/Kg	08/09/10 AF
-------------	-----	---	-----	-------	-------------

**Surrogates**

				Units	Control Limits
Triacontane (Sur)	79			%	60 - 140

**8081A - Organochlorine Pesticides by GC**

4,4-DDD	ND	1	0.005	mg/Kg	08/06/10 GH
4,4-DDE	ND	1	0.004	mg/Kg	08/06/10 GH
4,4-DDT	ND	1	0.005	mg/Kg	08/06/10 GH
Aldrin	ND	1	0.004	mg/Kg	08/06/10 GH
Alpha BHC	ND	1	0.002	mg/Kg	08/06/10 GH
Beta BHC	ND	1	0.003	mg/Kg	08/06/10 GH
Chlordane	ND	1	0.025	mg/Kg	08/06/10 GH

DLR = Detection limit for reporting purposes, ND = Not Detected below indicated detection limit, DF = Dilution Factor

**ASSOCIATED LABORATORIES**

Analytical Results Report





Order #: 1100714

Client: American Geotechnical

Matrix: SOLID

Client Sample ID: Drum # 5

Date Sampled: 08/03/2010

Time Sampled: 14:40

Sampled By:

Analyte	Result	DF	DLR	Units	Date/Analyst
<b>8081A - Organochlorine Pesticides by GC</b>					
Delta BHC	ND	1	0.005	mg/Kg	08/06/10 GH
Dieldrin	ND	1	0.003	mg/Kg	08/06/10 GH
Endosulfan I	ND	1	0.004	mg/Kg	08/06/10 GH
Endosulfan II	ND	1	0.004	mg/Kg	08/06/10 GH
Endosulfan sulfate	ND	1	0.004	mg/Kg	08/06/10 GH
Endrin	ND	1	0.004	mg/Kg	08/06/10 GH
Endrin aldehyde	ND	1	0.004	mg/Kg	08/06/10 GH
Endrin Ketone	ND	1	0.005	mg/Kg	08/06/10 GH
Heptachlor	ND	1	0.004	mg/Kg	08/06/10 GH
Heptachlor epoxide	ND	1	0.003	mg/Kg	08/06/10 GH
Lindane	ND	1	0.003	mg/Kg	08/06/10 GH
Methoxychlor	ND	1	0.025	mg/Kg	08/06/10 GH
Toxaphene	ND	1	0.250	mg/Kg	08/06/10 GH
<b>Surrogates</b>				<b>Units</b>	<b>Control Limits</b>
DCB(Sur2)	123			%	55 - 135
TCMX (Sur1)	106			%	50 - 125

**8260B Volatile Organic Compounds**

1,1,1,2-Tetrachloroethane	ND	1	5	ug/Kg	08/07/10 NZ
1,1,1-Trichloroethane	ND	1	5	ug/Kg	08/07/10 NZ
1,1,2,2-Tetrachloroethane	ND	1	5	ug/Kg	08/07/10 NZ
1,1,2-Trichloroethane	ND	1	5	ug/Kg	08/07/10 NZ
1,1,2-Trichlorotrifluoroethane	ND	1	5	ug/Kg	08/07/10 NZ
1,1-Dichloroethane	ND	1	5	ug/Kg	08/07/10 NZ
1,1-Dichloroethene	ND	1	5	ug/Kg	08/07/10 NZ
1,1-Dichloropropene	ND	1	5	ug/Kg	08/07/10 NZ
1,2,3-Trichlorobenzene	ND	1	5	ug/Kg	08/07/10 NZ
1,2,3-Trichloropropane	ND	1	5	ug/Kg	08/07/10 NZ
1,2,4-Trichlorobenzene	ND	1	5	ug/Kg	08/07/10 NZ
1,2,4-Trimethylbenzene	ND	1	5	ug/Kg	08/07/10 NZ
1,2-Dibromo-3-chloropropane	ND	1	5	ug/Kg	08/07/10 NZ
1,2-Dibromoethane	ND	1	5	ug/Kg	08/07/10 NZ
1,2-Dichlorobenzene	ND	1	5	ug/Kg	08/07/10 NZ
1,2-Dichloroethane	ND	1	5	ug/Kg	08/07/10 NZ
1,2-Dichloropropane	ND	1	5	ug/Kg	08/07/10 NZ
1,3,5-Trimethylbenzene	ND	1	5	ug/Kg	08/07/10 NZ
1,3-Dichlorobenzene	ND	1	5	ug/Kg	08/07/10 NZ

DLR = Detection limit for reporting purposes, ND = Not Detected below indicated detection limit, DF = Dilution Factor

**ASSOCIATED LABORATORIES**

Analytical Results Report



Order #: 1100714

Client: American Geotechnical

Matrix: SOLID

Client Sample ID: Drum # 5

Date Sampled: 08/03/2010

Time Sampled: 14:40

Sampled By:

Analyte	Result	DF	DLR	Units	Date/Analyst
<b>8260B Volatile Organic Compounds</b>					
1,3-Dichloropropane	ND	1	5	ug/Kg	08/07/10 NZ
1,4-Dichlorobenzene	ND	1	5	ug/Kg	08/07/10 NZ
2,2-Dichloropropane	ND	1	5	ug/Kg	08/07/10 NZ
2-Butanone (MEK)	ND	1	100	ug/Kg	08/07/10 NZ
2-Chloroethyl vinyl ether	ND	1	5	ug/Kg	08/07/10 NZ
2-Chlorotoluene	ND	1	5	ug/Kg	08/07/10 NZ
4-Chlorotoluene	ND	1	5	ug/Kg	08/07/10 NZ
4-Methyl -2- Pentanone (MIBK)	ND	1	5	ug/Kg	08/07/10 NZ
Acetone	ND	1	50	ug/Kg	08/07/10 NZ
Allyl chloride	ND	1	5	ug/Kg	08/07/10 NZ
Benzene	ND	1	5	ug/Kg	08/07/10 NZ
Bromobenzene	ND	1	5	ug/Kg	08/07/10 NZ
Bromochloromethane	ND	1	5	ug/Kg	08/07/10 NZ
Bromodichloromethane	ND	1	5	ug/Kg	08/07/10 NZ
Bromoform	ND	1	5	ug/Kg	08/07/10 NZ
Bromomethane	ND	1	5	ug/Kg	08/07/10 NZ
Carbon tetrachloride	ND	1	5	ug/Kg	08/07/10 NZ
Chlorobenzene	ND	1	5	ug/Kg	08/07/10 NZ
Chloroethane	ND	1	5	ug/Kg	08/07/10 NZ
Chloroform	ND	1	5	ug/Kg	08/07/10 NZ
Chloromethane	ND	1	5	ug/Kg	08/07/10 NZ
cis-1,2-Dichloroethene	ND	1	5	ug/Kg	08/07/10 NZ
cis-1,3-Dichloropropene	ND	1	5	ug/Kg	08/07/10 NZ
cis-1,4-Dichloro-2-butene	ND	1	5	ug/Kg	08/07/10 NZ
Dibromochloromethane	ND	1	5	ug/Kg	08/07/10 NZ
Dibromomethane	ND	1	5	ug/Kg	08/07/10 NZ
Dichlorodifluoromethane	ND	1	5	ug/Kg	08/07/10 NZ
Ethyl benzene	ND	1	5	ug/Kg	08/07/10 NZ
Hexachlorobutadiene	ND	1	5	ug/Kg	08/07/10 NZ
Isopropylbenzene (Cumene)	ND	1	5	ug/Kg	08/07/10 NZ
m and p-Xylene	ND	1	5	ug/Kg	08/07/10 NZ
Methyl-tert-butylether (MTBE)	ND	1	5	ug/Kg	08/07/10 NZ
Methylene chloride	ND	1	5	ug/Kg	08/07/10 NZ
n-Butylbenzene	ND	1	5	ug/Kg	08/07/10 NZ
n-Propylbenzene	ND	1	5	ug/Kg	08/07/10 NZ
Naphthalene	ND	1	5	ug/Kg	08/07/10 NZ
o-Xylene	ND	1	5	ug/Kg	08/07/10 NZ
p-Isopropyltoluene	ND	1	5	ug/Kg	08/07/10 NZ
sec-Butylbenzene	ND	1	5	ug/Kg	08/07/10 NZ

DLR = Detection limit for reporting purposes, ND = Not Detected below indicated detection limit, DF = Dilution Factor

**ASSOCIATED LABORATORIES**

Analytical Results Report



Order #: 1100714

Client: American Geotechnical

Matrix: SOLID

Client Sample ID: Drum # 5

Date Sampled: 08/03/2010

Time Sampled: 14:40

Sampled By:

Analyte	Result	DF	DLR	Units	Date/Analyst
<b>8260B Volatile Organic Compounds</b>					
Styrene	ND	1	5	ug/Kg	08/07/10 NZ
tert-Butylbenzene	ND	1	5	ug/Kg	08/07/10 NZ
Tetrachloroethene	ND	1	5	ug/Kg	08/07/10 NZ
Toluene	ND	1	5	ug/Kg	08/07/10 NZ
trans-1,2-Dichloroethene	ND	1	5	ug/Kg	08/07/10 NZ
trans-1,3-Dichloropropene	ND	1	5	ug/Kg	08/07/10 NZ
trans-1,4-Dichloro-2-butene	ND	1	5	ug/Kg	08/07/10 NZ
Trichloroethene	ND	1	5	ug/Kg	08/07/10 NZ
Trichlorofluoromethane	ND	1	5	ug/Kg	08/07/10 NZ
Vinyl chloride	ND	1	5	ug/Kg	08/07/10 NZ
Xylenes, total	ND	1	5	ug/Kg	08/07/10 NZ
Di-isopropyl ether (DIPE)	ND	1	2.0	ug/Kg	08/07/10 NZ
Ethyl-tertbutylether (ETBE)	ND	1	2.0	ug/Kg	08/07/10 NZ
Tert-amylmethylether (TAME)	ND	1	2.0	ug/Kg	08/07/10 NZ
Tertiary butyl alcohol (TBA)	ND	1	10	ug/Kg	08/07/10 NZ
<b>Surrogates</b>				<b>Units</b>	<b>Control Limits</b>
Surr1 - Dibromofluoromethane	100			%	70 - 135
Surr2 - 1,2-Dichloroethane-d4	111			%	70 - 135
Surr3 - Toluene-d8	104			%	70 - 135
Surr4 - p-Bromofluorobenzene	102			%	70 - 135
<b>8270C Acid/Base/Neutral Extractables</b>					
1,2,4-Trichlorobenzene	ND	1	300	ug/Kg	08/09/10 SD
1,2-Dichlorobenzene	ND	1	300	ug/Kg	08/09/10 SD
1,3-Dichlorobenzene	ND	1	300	ug/Kg	08/09/10 SD
1,4-Dichlorobenzene	ND	1	300	ug/Kg	08/09/10 SD
2,4,5-Trichlorophenol	ND	1	300	ug/Kg	08/09/10 SD
2,4,6-Trichlorophenol	ND	1	300	ug/Kg	08/09/10 SD
2,4-Dichlorophenol	ND	1	300	ug/Kg	08/09/10 SD
2,4-Dimethylphenol	ND	1	300	ug/Kg	08/09/10 SD
2,4-Dinitrophenol	ND	1	300	ug/Kg	08/09/10 SD
2,4-Dinitrotoluene	ND	1	300	ug/Kg	08/09/10 SD
2,6-Dinitrotoluene	ND	1	300	ug/Kg	08/09/10 SD
2-Chloronaphthalene	ND	1	300	ug/Kg	08/09/10 SD
2-Chlorophenol	ND	1	300	ug/Kg	08/09/10 SD
2-Methylnaphthalene	ND	1	300	ug/Kg	08/09/10 SD
2-Methylphenol	ND	1	300	ug/Kg	08/09/10 SD

DLR = Detection limit for reporting purposes, ND = Not Detected below indicated detection limit, DF = Dilution Factor

**ASSOCIATED LABORATORIES**

Analytical Results Report



Order #: 1100714

Client: American Geotechnical

Matrix: SOLID

Client Sample ID: Drum # 5

Date Sampled: 08/03/2010

Time Sampled: 14:40

Sampled By:

Analyte	Result	DF	DLR	Units	Date/Analyst
<b>8270C Acid/Base/Neutral Extractables</b>					
2-Nitroaniline	ND	1	300	ug/Kg	08/09/10 SD
2-Nitrophenol	ND	1	300	ug/Kg	08/09/10 SD
3,3-Dichlorobenzidine	ND	1	300	ug/Kg	08/09/10 SD
3-Methylphenol	ND	1	500	ug/Kg	08/09/10 SD
3-Nitroaniline	ND	1	300	ug/Kg	08/09/10 SD
4,6-Dinitro-2-methylphenol	ND	1	300	ug/Kg	08/09/10 SD
4-Bromophenyl-phenylether	ND	1	300	ug/Kg	08/09/10 SD
4-Chloro-3-methylphenol	ND	1	300	ug/Kg	08/09/10 SD
4-Chloroaniline	ND	1	300	ug/Kg	08/09/10 SD
4-Chlorophenyl-phenylether	ND	1	300	ug/Kg	08/09/10 SD
4-Methylphenol	ND	1	500	ug/Kg	08/09/10 SD
4-Nitroaniline	ND	1	300	ug/Kg	08/09/10 SD
4-Nitrophenol	ND	1	300	ug/Kg	08/09/10 SD
Acenaphthene	ND	1	300	ug/Kg	08/09/10 SD
Acenaphthylene	ND	1	300	ug/Kg	08/09/10 SD
Anthracene	ND	1	300	ug/Kg	08/09/10 SD
Benzidine	ND	1	1500	ug/Kg	08/09/10 SD
Benzo(a)anthracene	ND	1	300	ug/Kg	08/09/10 SD
Benzo(a)pyrene	ND	1	300	ug/Kg	08/09/10 SD
Benzo(b)fluoranthene	ND	1	300	ug/Kg	08/09/10 SD
Benzo(g,h,i)perylene	ND	1	300	ug/Kg	08/09/10 SD
Benzo(k)fluoranthene	ND	1	300	ug/Kg	08/09/10 SD
Benzoic Acid	ND	1	300	ug/Kg	08/09/10 SD
Benzyl alcohol	ND	1	300	ug/Kg	08/09/10 SD
bis(2-Chloroethoxy)methane	ND	1	300	ug/Kg	08/09/10 SD
bis(2-Chloroethyl)ether	ND	1	300	ug/Kg	08/09/10 SD
bis(2-Chloroisopropyl) ether	ND	1	300	ug/Kg	08/09/10 SD
bis(2-Ethylhexyl)phthalate	ND	1	300	ug/Kg	08/09/10 SD
Butylbenzylphthalate	ND	1	300	ug/Kg	08/09/10 SD
Chrysene	ND	1	300	ug/Kg	08/09/10 SD
Di-n-butylphthalate	ND	1	300	ug/Kg	08/09/10 SD
Di-n-octylphthalate	ND	1	300	ug/Kg	08/09/10 SD
Dibenz(a,h)anthracene	ND	1	300	ug/Kg	08/09/10 SD
Dibenzofuran	ND	1	300	ug/Kg	08/09/10 SD
Diethylphthalate	ND	1	300	ug/Kg	08/09/10 SD
Dimethylphthalate	ND	1	300	ug/Kg	08/09/10 SD
Fluoranthene	ND	1	300	ug/Kg	08/09/10 SD
Fluorene	ND	1	300	ug/Kg	08/09/10 SD
Hexachlorobenzene	ND	1	300	ug/Kg	08/09/10 SD

DLR = Detection limit for reporting purposes, ND = Not Detected below indicated detection limit, DF = Dilution Factor

ASSOCIATED LABORATORIES

Analytical Results Report



Order #: 1100714

Client: American Geotechnical

Matrix: SOLID

Client Sample ID: Drum # 5

Date Sampled: 08/03/2010

Time Sampled: 14:40

Sampled By:

Analyte	Result	DF	DLR	Units	Date/Analyst
---------	--------	----	-----	-------	--------------

**8270C Acid/Base/Neutral Extractables**

Hexachlorobutadiene	ND	1	300	ug/Kg	08/09/10 SD
Hexachlorocyclopentadiene	ND	1	300	ug/Kg	08/09/10 SD
Hexachloroethane	ND	1	300	ug/Kg	08/09/10 SD
Indeno(1,2,3-c,d)pyrene	ND	1	300	ug/Kg	08/09/10 SD
Isophorone	ND	1	300	ug/Kg	08/09/10 SD
N-Nitroso-di-n-propylamine	ND	1	300	ug/Kg	08/09/10 SD
N-Nitrosodiphenylamine	ND	1	300	ug/Kg	08/09/10 SD
Naphthalene	ND	1	300	ug/Kg	08/09/10 SD
Nitrobenzene	ND	1	300	ug/Kg	08/09/10 SD
Pentachlorophenol	ND	1	300	ug/Kg	08/09/10 SD
Phenanthrene	ND	1	300	ug/Kg	08/09/10 SD
Phenol	ND	1	300	ug/Kg	08/09/10 SD
Pyrene	ND	1	300	ug/Kg	08/09/10 SD

**Surrogates**

				Units	Control Limits
2,4,6-Tribromophenol (sur)	51			%	17 - 122
2-Fluorobiphenyl (sur)	77			%	30 - 115
2-Fluorophenol (sur)	69			%	25 - 121
Nitrobenzene-d5 (sur)	62			%	23 - 120
Phenol-d5 (sur)	69			%	24 - 113
Terphenyl-d14 (sur)	86			%	18 - 137

**8015B - Gasoline**

Gasoline	ND	1	3	mg/Kg	08/06/10 LT
----------	----	---	---	-------	-------------

**Surrogates**

				Units	Control Limits
p-Bromofluorobenzene (Sur)	131			%	60 - 140

DLR = Detection limit for reporting purposes, ND = Not Detected below indicated detection limit, DF = Dilution Factor

**ASSOCIATED LABORATORIES**

Analytical Results Report



Order #: 1100715

Client: American Geotechnical

Matrix: WATER

Client Sample ID: WS 1,2,3

Date Sampled: 08/04/2010

Time Sampled: 14:15

Sampled By:

Analyte	Result	DF	DLR	Units	Date/Analyst
---------	--------	----	-----	-------	--------------

**6010B ICP CAM Metals Only (W/S/W)**

Antimony	ND	1	0.02	mg/L	08/06/10 KN
Arsenic	0.039	1	0.01	mg/L	08/06/10 KN
Barium	0.033	1	0.01	mg/L	08/06/10 KN
Beryllium	ND	1	0.005	mg/L	08/06/10 KN
Cadmium	ND	1	0.005	mg/L	08/06/10 KN
Chromium	0.016	1	0.01	mg/L	08/06/10 KN
Cobalt	ND	1	0.005	mg/L	08/06/10 KN
Copper	ND	1	0.01	mg/L	08/06/10 KN
Lead	ND	1	0.005	mg/L	08/06/10 KN
Molybdenum	0.043	1	0.01	mg/L	08/06/10 KN
Nickel	ND	1	0.02	mg/L	08/06/10 KN
Selenium	0.012	1	0.010	mg/L	08/06/10 KN
Silver	ND	1	0.005	mg/L	08/06/10 KN
Thallium	ND	1	0.005	mg/L	08/06/10 KN
Vanadium	0.078	1	0.005	mg/L	08/06/10 KN
Zinc	ND	1	0.02	mg/L	08/06/10 KN

**7470A Mercury in Water**

Mercury	ND	1	0.0004	mg/L	08/06/10 NF
---------	----	---	--------	------	-------------

**8015 TEPH Diesel**

TEPH Diesel	0.2	1	0.1	mg/L	08/09/10 AF
-------------	-----	---	-----	------	-------------

**Surrogates**

				Units	Control Limits
Triacontane (Sur)	140			%	60 - 140

**8081A - Organochlorine Pesticides by GC**

4,4-DDD	ND	1	0.06	ug/L	08/09/10 GH
4,4-DDE	ND	1	0.05	ug/L	08/09/10 GH
4,4-DDT	ND	1	0.06	ug/L	08/09/10 GH
Aldrin	ND	1	0.11	ug/L	08/09/10 GH
Alpha BHC	ND	1	0.04	ug/L	08/09/10 GH
Beta BHC	ND	1	0.03	ug/L	08/09/10 GH
Chlordane	ND	1	0.25	ug/L	08/09/10 GH

DLR = Detection limit for reporting purposes, ND = Not Detected below indicated detection limit, DF = Dilution Factor



Order #: 1100715

Client: American Geotechnical

Matrix: WATER

Client Sample ID: WS 1,2,3

Date Sampled: 08/04/2010

Time Sampled: 14:15

Sampled By:

Analyte	Result	DF	DLR	Units	Date/Analyst
---------	--------	----	-----	-------	--------------

**8081A - Organochlorine Pesticides by GC**

Delta BHC	ND	1	0.03	ug/L	08/09/10 GH
Dieldrin	ND	1	0.06	ug/L	08/09/10 GH
Endosulfan I	ND	1	0.03	ug/L	08/09/10 GH
Endosulfan II	ND	1	0.06	ug/L	08/09/10 GH
Endosulfan sulfate	ND	1	0.06	ug/L	08/09/10 GH
Endrin	ND	1	0.06	ug/L	08/09/10 GH
Endrin aldehyde	ND	1	0.13	ug/L	08/09/10 GH
Endrin Ketone	ND	1	0.05	ug/L	08/09/10 GH
Heptachlor	ND	1	0.08	ug/L	08/09/10 GH
Heptachlor epoxide	ND	1	0.05	ug/L	08/09/10 GH
Lindane	ND	1	0.03	ug/L	08/09/10 GH
Methoxychlor	ND	1	0.57	ug/L	08/09/10 GH
Toxaphene	ND	1	3.13	ug/L	08/09/10 GH

**Surrogates**

				Units	Control Limits
DCB(Sur2)	75			%	55 - 130
TCMX (Sur1)	95			%	50 - 125

**8260B Volatile Organic Compounds**

1,1,1,2-Tetrachloroethane	ND	1	5	ug/L	08/07/10 LZ
1,1,1-Trichloroethane	ND	1	5	ug/L	08/07/10 LZ
1,1,2,2-Tetrachloroethane	ND	1	5	ug/L	08/07/10 LZ
1,1,2-Trichloroethane	ND	1	5	ug/L	08/07/10 LZ
1,1,2-Trichlorotrifluoroethane	ND	1	5	ug/L	08/07/10 LZ
1,1-Dichloroethane	ND	1	5	ug/L	08/07/10 LZ
1,1-Dichloroethene	ND	1	5	ug/L	08/07/10 LZ
1,1-Dichloropropene	ND	1	5	ug/L	08/07/10 LZ
1,2,3-Trichlorobenzene	ND	1	5	ug/L	08/07/10 LZ
1,2,3-Trichloropropane	ND	1	5	ug/L	08/07/10 LZ
1,2,4-Trichlorobenzene	ND	1	5	ug/L	08/07/10 LZ
1,2,4-Trimethylbenzene	ND	1	5	ug/L	08/07/10 LZ
1,2-Dibromo-3-chloropropane	ND	1	5	ug/L	08/07/10 LZ
1,2-Dibromoethane	ND	1	5	ug/L	08/07/10 LZ
1,2-Dichlorobenzene	ND	1	5	ug/L	08/07/10 LZ
1,2-Dichloroethane	ND	1	5	ug/L	08/07/10 LZ
1,2-Dichloropropane	ND	1	5	ug/L	08/07/10 LZ
1,3,5-Trimethylbenzene	ND	1	5	ug/L	08/07/10 LZ
1,3-Dichlorobenzene	ND	1	5	ug/L	08/07/10 LZ

DLR = Detection limit for reporting purposes, ND = Not Detected below indicated detection limit, DF = Dilution Factor

**ASSOCIATED LABORATORIES**

Analytical Results Report



Order #: 1100715

Client: American Geotechnical

Matrix: WATER

Client Sample ID: WS 1,2,3

Date Sampled: 08/04/2010

Time Sampled: 14:15

Sampled By:

Analyte	Result	DF	DLR	Units	Date/Analyst
<b>8260B Volatile Organic Compounds</b>					
1,3-Dichloropropane	ND	1	5	ug/L	08/07/10 LZ
1,4-Dichlorobenzene	ND	1	5	ug/L	08/07/10 LZ
2,2-Dichloropropane	ND	1	5	ug/L	08/07/10 LZ
2-Butanone (MEK)	ND	1	100	ug/L	08/07/10 LZ
2-Chloroethyl vinyl ether	ND	1	5	ug/L	08/07/10 LZ
2-Chlorotoluene	ND	1	5	ug/L	08/07/10 LZ
4-Chlorotoluene	ND	1	5	ug/L	08/07/10 LZ
4-Methyl -2- Pentanone (MIBK)	ND	1	10	ug/L	08/07/10 LZ
Acetone	ND	1	100	ug/L	08/07/10 LZ
Allyl chloride	ND	1	5	ug/L	08/07/10 LZ
Benzene	ND	1	1	ug/L	08/07/10 LZ
Bromobenzene	ND	1	5	ug/L	08/07/10 LZ
Bromochloromethane	ND	1	5	ug/L	08/07/10 LZ
Bromodichloromethane	ND	1	5	ug/L	08/07/10 LZ
Bromoform	ND	1	5	ug/L	08/07/10 LZ
Bromomethane	ND	1	5	ug/L	08/07/10 LZ
Carbon tetrachloride	ND	1	5	ug/L	08/07/10 LZ
Chlorobenzene	ND	1	5	ug/L	08/07/10 LZ
Chloroethane	ND	1	5	ug/L	08/07/10 LZ
Chloroform	ND	1	5	ug/L	08/07/10 LZ
Chloromethane	ND	1	5	ug/L	08/07/10 LZ
cis-1,2-Dichloroethene	ND	1	5	ug/L	08/07/10 LZ
cis-1,3-Dichloropropene	ND	1	5	ug/L	08/07/10 LZ
cis-1,4-Dichloro-2-butene	ND	1	20	ug/L	08/07/10 LZ
Dibromochloromethane	ND	1	5	ug/L	08/07/10 LZ
Dibromomethane	ND	1	5	ug/L	08/07/10 LZ
Dichlorodifluoromethane	ND	1	5	ug/L	08/07/10 LZ
Ethyl benzene	ND	1	5	ug/L	08/07/10 LZ
Hexachlorobutadiene	ND	1	5	ug/L	08/07/10 LZ
Isopropylbenzene (Cumene)	ND	1	5	ug/L	08/07/10 LZ
m and p-Xylene	5.4	1	5	ug/L	08/07/10 LZ
Methyl-tert-butylether (MTBE)	ND	1	1	ug/L	08/07/10 LZ
Methylene chloride	ND	1	5	ug/L	08/07/10 LZ
n-Butylbenzene	ND	1	5	ug/L	08/07/10 LZ
n-Propylbenzene	ND	1	5	ug/L	08/07/10 LZ
Naphthalene	ND	1	5	ug/L	08/07/10 LZ
o-Xylene	ND	1	5	ug/L	08/07/10 LZ
p-Isopropyltoluene	ND	1	5	ug/L	08/07/10 LZ
sec-Butylbenzene	ND	1	5	ug/L	08/07/10 LZ

DLR = Detection limit for reporting purposes, ND = Not Detected below indicated detection limit, DF = Dilution Factor

ASSOCIATED LABORATORIES

Analytical Results Report





Order #: 1100715

Client: American Geotechnical

Matrix: WATER

Client Sample ID: WS 1,2,3

Date Sampled: 08/04/2010

Time Sampled: 14:15

Sampled By:

Analyte	Result	DF	DLR	Units	Date/Analyst
---------	--------	----	-----	-------	--------------

**8260B Volatile Organic Compounds**

Styrene	ND	1	5	ug/L	08/07/10 LZ
tert-Butylbenzene	ND	1	5	ug/L	08/07/10 LZ
Tetrachloroethene	ND	1	5	ug/L	08/07/10 LZ
Toluene	ND	1	5	ug/L	08/07/10 LZ
trans-1,2-Dichloroethene	ND	1	5	ug/L	08/07/10 LZ
trans-1,3-Dichloropropene	ND	1	5	ug/L	08/07/10 LZ
trans-1,4-Dichloro-2-butene	ND	1	20	ug/L	08/07/10 LZ
Trichloroethene	ND	1	5	ug/L	08/07/10 LZ
Trichlorofluoromethane	ND	1	5	ug/L	08/07/10 LZ
Vinyl chloride	ND	1	5	ug/L	08/07/10 LZ
Xylenes, total	5.4	1	5	ug/L	08/07/10 LZ
Di-isopropyl ether (DIPE)	ND	1	1.0	ug/L	08/07/10 LZ
Ethyl-tertbuylether (ETBE)	ND	1	1.0	ug/L	08/07/10 LZ
Tert-amylmethylether (TAME)	ND	1	1.0	ug/L	08/07/10 LZ
Tertiary butyl alcohol (TBA)	ND	1	10	ug/L	08/07/10 LZ

**Surrogates**

				Units	Control Limits
Surr1 - Dibromofluoromethane	81			%	70 - 135
Surr2 - 1,2-Dichloroethane-d4	109			%	70 - 135
Surr3 - Toluene-d8	95			%	70 - 135
Surr4 - p-Bromofluorobenzene	96			%	70 - 135

**8270C Acid/Base/Neutral Extractables**

1,2,4-Trichlorobenzene	ND	1	10	ug/L	08/09/10 SD
1,2-Dichlorobenzene	ND	1	10	ug/L	08/09/10 SD
1,3-Dichlorobenzene	ND	1	10	ug/L	08/09/10 SD
1,4-Dichlorobenzene	ND	1	10	ug/L	08/09/10 SD
2,4,5-Trichlorophenol	ND	1	10	ug/L	08/09/10 SD
2,4,6-Trichlorophenol	ND	1	10	ug/L	08/09/10 SD
2,4-Dichlorophenol	ND	1	10	ug/L	08/09/10 SD
2,4-Dimethylphenol	ND	1	10	ug/L	08/09/10 SD
2,4-Dinitrophenol	ND	1	10	ug/L	08/09/10 SD
2,4-Dinitrotoluene	ND	1	10	ug/L	08/09/10 SD
2,6-Dinitrotoluene	ND	1	10	ug/L	08/09/10 SD
2-Chloronaphthalene	ND	1	10	ug/L	08/09/10 SD
2-Chlorophenol	ND	1	10	ug/L	08/09/10 SD
2-Methylnaphthalene	ND	1	10	ug/L	08/09/10 SD
2-Methylphenol	ND	1	10	ug/L	08/09/10 SD

DLR = Detection limit for reporting purposes, ND = Not Detected below indicated detection limit, DF = Dilution Factor

**ASSOCIATED LABORATORIES**

Analytical Results Report



Order #: 1100715

Client: American Geotechnical

Matrix: WATER

Client Sample ID: WS 1,2,3

Date Sampled: 08/04/2010

Time Sampled: 14:15

Sampled By:

Analyte	Result	DF	DLR	Units	Date/Analyst
<b>8270C Acid/Base/Neutral Extractables</b>					
2-Nitroaniline	ND	1	50	ug/L	08/09/10 SD
2-Nitrophenol	ND	1	10	ug/L	08/09/10 SD
3,3-Dichlorobenzidine	ND	1	10	ug/L	08/09/10 SD
3-Methylphenol	ND	1	10	ug/L	08/09/10 SD
3-Nitroaniline	ND	1	10	ug/L	08/09/10 SD
4,6-Dinitro-2-methylphenol	ND	1	10	ug/L	08/09/10 SD
4-Bromophenyl-phenylether	ND	1	10	ug/L	08/09/10 SD
4-Chloro-3-methylphenol	ND	1	10	ug/L	08/09/10 SD
4-Chloroaniline	ND	1	10	ug/L	08/09/10 SD
4-Chlorophenyl-phenylether	ND	1	10	ug/L	08/09/10 SD
4-Methylphenol	ND	1	10	ug/L	08/09/10 SD
4-Nitroaniline	ND	1	10	ug/L	08/09/10 SD
4-Nitrophenol	ND	1	10	ug/L	08/09/10 SD
Acenaphthene	ND	1	10	ug/L	08/09/10 SD
Acenaphthylene	ND	1	10	ug/L	08/09/10 SD
Anthracene	ND	1	10	ug/L	08/09/10 SD
Benzidine	ND	1	10	ug/L	08/09/10 SD
Benzo(a)anthracene	ND	1	10	ug/L	08/09/10 SD
Benzo(a)pyrene	ND	1	10	ug/L	08/09/10 SD
Benzo(b)fluoranthene	ND	1	10	ug/L	08/09/10 SD
Benzo(g,h,i)perylene	ND	1	10	ug/L	08/09/10 SD
Benzo(k)fluoranthene	ND	1	10	ug/L	08/09/10 SD
Benzoic Acid	51	1	10	ug/L	08/09/10 SD
Benzyl alcohol	ND	1	10	ug/L	08/09/10 SD
bis(2-Chloroethoxy)methane	ND	1	10	ug/L	08/09/10 SD
bis(2-Chloroethyl)ether	ND	1	10	ug/L	08/09/10 SD
bis(2-Chloroisopropyl) ether	ND	1	10	ug/L	08/09/10 SD
bis(2-Ethylhexyl)phthalate	ND	1	10	ug/L	08/09/10 SD
Butylbenzylphthalate	ND	1	10	ug/L	08/09/10 SD
Chrysene	ND	1	10	ug/L	08/09/10 SD
Di-n-butylphthalate	ND	1	10	ug/L	08/09/10 SD
Di-n-octylphthalate	ND	1	10	ug/L	08/09/10 SD
Dibenz(a,h)anthracene	ND	1	10	ug/L	08/09/10 SD
Dibenzofuran	ND	1	10	ug/L	08/09/10 SD
Diethylphthalate	ND	1	10	ug/L	08/09/10 SD
Dimethylphthalate	ND	1	10	ug/L	08/09/10 SD
Fluoranthene	ND	1	10	ug/L	08/09/10 SD
Fluorene	ND	1	10	ug/L	08/09/10 SD
Hexachlorobenzene	ND	1	10	ug/L	08/09/10 SD

DLR = Detection limit for reporting purposes, ND = Not Detected below indicated detection limit, DF = Dilution Factor

**ASSOCIATED LABORATORIES**

Analytical Results Report



Order #: 1100715

Client: American Geotechnical

Matrix: WATER

Client Sample ID: WS 1,2,3

Date Sampled: 08/04/2010

Time Sampled: 14:15

Sampled By:

Analyte	Result	DF	DLR	Units	Date/Analyst
---------	--------	----	-----	-------	--------------

**8270C Acid/Base/Neutral Extractables**

Hexachlorobutadiene	ND	1	10	ug/L	08/09/10 SD
Hexachlorocyclopentadiene	ND	1	10	ug/L	08/09/10 SD
Hexachloroethane	ND	1	10	ug/L	08/09/10 SD
Indeno(1,2,3-c,d)pyrene	ND	1	10	ug/L	08/09/10 SD
Isophorone	ND	1	10	ug/L	08/09/10 SD
N-Nitroso-di-n-propylamine	ND	1	10	ug/L	08/09/10 SD
N-Nitrosodiphenylamine	ND	1	10	ug/L	08/09/10 SD
Naphthalene	ND	1	10	ug/L	08/09/10 SD
Nitrobenzene	ND	1	10	ug/L	08/09/10 SD
Pentachlorophenol	ND	1	10	ug/L	08/09/10 SD
Phenanthrene	ND	1	10	ug/L	08/09/10 SD
Phenol	ND	1	10	ug/L	08/09/10 SD
Pyrene	ND	1	10	ug/L	08/09/10 SD

**Surrogates**

				Units	Control Limits
2,4,6-Tribromophenol (sur)	87			%	10 - 123
2-Fluorobiphenyl (sur)	65			%	43 - 116
2-Fluorophenol (sur)	49			%	21 - 110
Nitrobenzene-d5 (sur)	49			%	34 - 114
Phenol-d5 (sur)	38			%	10 - 110
Terphenyl-d14 (sur)	87			%	33 - 141

**8015B - Gasoline**

Gasoline	72	1	50	ug/L	08/05/10 LT
----------	----	---	----	------	-------------

**Surrogates**

				Units	Control Limits
p-Bromofluorobenzene (Sur)	114			%	60 - 140

DLR = Detection limit for reporting purposes, ND = Not Detected below indicated detection limit, DF = Dilution Factor



Order #: 1100716

Client: American Geotechnical

Matrix: SOLID

Client Sample ID: Laboratory Method Blank

Date Sampled:

Time Sampled:

Sampled By:

Analyte	Result	DF	DLR	Units	Date/Analyst
---------	--------	----	-----	-------	--------------

**6010B ICP CAM Metals Only (W/S/W)**

Antimony	ND	1	3.00	mg/Kg	08/06/10 KN
Arsenic	ND	1	1.00	mg/Kg	08/06/10 KN
Barium	ND	1	1.00	mg/Kg	08/06/10 KN
Beryllium	ND	1	0.50	mg/Kg	08/06/10 KN
Cadmium	ND	1	0.50	mg/Kg	08/06/10 KN
Chromium	ND	1	1.00	mg/Kg	08/06/10 KN
Cobalt	ND	1	0.50	mg/Kg	08/06/10 KN
Copper	ND	1	1.00	mg/Kg	08/06/10 KN
Lead	ND	1	0.50	mg/Kg	08/06/10 KN
Molybdenum	ND	1	1.00	mg/Kg	08/06/10 KN
Nickel	ND	1	1.50	mg/Kg	08/06/10 KN
Selenium	ND	1	1.00	mg/Kg	08/06/10 KN
Silver	ND	1	0.50	mg/Kg	08/06/10 KN
Thallium	ND	1	1.00	mg/Kg	08/06/10 KN
Vanadium	ND	1	0.50	mg/Kg	08/06/10 KN
Zinc	ND	1	5.00	mg/Kg	08/06/10 KN

**7471A Mercury in Solid/Wipe**

Mercury	ND	1	0.14	mg/Kg	08/06/10 NF
---------	----	---	------	-------	-------------

**8015 TEPH Diesel**

TEPH Diesel	ND	1	1.0	mg/Kg	08/05/10 AF
-------------	----	---	-----	-------	-------------

**Surrogates**

				Units	Control Limits
Triacontane (Sur)	83			%	60 - 140

**8081A - Organochlorine Pesticides by GC**

4,4-DDD	ND	1	0.005	mg/Kg	08/06/10 GH
4,4-DDE	ND	1	0.004	mg/Kg	08/06/10 GH
4,4-DDT	ND	1	0.005	mg/Kg	08/06/10 GH
Aldrin	ND	1	0.004	mg/Kg	08/06/10 GH
Alpha BHC	ND	1	0.002	mg/Kg	08/06/10 GH
Beta BHC	ND	1	0.003	mg/Kg	08/06/10 GH
Chlordane	ND	1	0.025	mg/Kg	08/06/10 GH

DLR = Detection limit for reporting purposes, ND = Not Detected below indicated detection limit, DF = Dilution Factor

**ASSOCIATED LABORATORIES**

Analytical Results Report



Order #: 1100716

Client: American Geotechnical

Matrix: SOLID

Client Sample ID: Laboratory Method Blank

Date Sampled:

Time Sampled:

Sampled By:

Analyte	Result	DF	DLR	Units	Date/Analyst
<b>8081A - Organochlorine Pesticides by GC</b>					
Delta BHC	ND	1	0.005	mg/Kg	08/06/10 GH
Dieldrin	ND	1	0.003	mg/Kg	08/06/10 GH
Endosulfan I	ND	1	0.004	mg/Kg	08/06/10 GH
Endosulfan II	ND	1	0.004	mg/Kg	08/06/10 GH
Endosulfan sulfate	ND	1	0.004	mg/Kg	08/06/10 GH
Endrin	ND	1	0.004	mg/Kg	08/06/10 GH
Endrin aldehyde	ND	1	0.004	mg/Kg	08/06/10 GH
Endrin Ketone	ND	1	0.005	mg/Kg	08/06/10 GH
Heptachlor	ND	1	0.004	mg/Kg	08/06/10 GH
Heptachlor epoxide	ND	1	0.003	mg/Kg	08/06/10 GH
Lindane	ND	1	0.003	mg/Kg	08/06/10 GH
Methoxychlor	ND	1	0.025	mg/Kg	08/06/10 GH
Toxaphene	ND	1	0.250	mg/Kg	08/06/10 GH
<b>Surrogates</b>				<b>Units</b>	<b>Control Limits</b>
DCB(Sur2)	95			%	55 - 135
TCMX (Sur1)	100			%	50 - 125

**8260B Volatile Organic Compounds**

1,1,1,2-Tetrachloroethane	ND	1	5	ug/Kg	08/06/10 NZ
1,1,1-Trichloroethane	ND	1	5	ug/Kg	08/06/10 NZ
1,1,2,2-Tetrachloroethane	ND	1	5	ug/Kg	08/06/10 NZ
1,1,2-Trichloroethane	ND	1	5	ug/Kg	08/06/10 NZ
1,1,2-Trichlorotrifluoroethane	ND	1	5	ug/Kg	08/06/10 NZ
1,1-Dichloroethane	ND	1	5	ug/Kg	08/06/10 NZ
1,1-Dichloroethene	ND	1	5	ug/Kg	08/06/10 NZ
1,1-Dichloropropene	ND	1	5	ug/Kg	08/06/10 NZ
1,2,3-Trichlorobenzene	ND	1	5	ug/Kg	08/06/10 NZ
1,2,3-Trichloropropane	ND	1	5	ug/Kg	08/06/10 NZ
1,2,4-Trichlorobenzene	ND	1	5	ug/Kg	08/06/10 NZ
1,2,4-Trimethylbenzene	ND	1	5	ug/Kg	08/06/10 NZ
1,2-Dibromo-3-chloropropane	ND	1	5	ug/Kg	08/06/10 NZ
1,2-Dibromoethane	ND	1	5	ug/Kg	08/06/10 NZ
1,2-Dichlorobenzene	ND	1	5	ug/Kg	08/06/10 NZ
1,2-Dichloroethane	ND	1	5	ug/Kg	08/06/10 NZ
1,2-Dichloropropane	ND	1	5	ug/Kg	08/06/10 NZ
1,3,5-Trimethylbenzene	ND	1	5	ug/Kg	08/06/10 NZ
1,3-Dichlorobenzene	ND	1	5	ug/Kg	08/06/10 NZ

DLR = Detection limit for reporting purposes, ND = Not Detected below indicated detection limit, DF = Dilution Factor

**ASSOCIATED LABORATORIES**

Analytical Results Report



Order #: 1100716

Client: American Geotechnical

Matrix: SOLID

Client Sample ID: Laboratory Method Blank

Date Sampled:

Time Sampled:

Sampled By:

Analyte	Result	DF	DLR	Units	Date/Analyst
<b>8260B Volatile Organic Compounds</b>					
1,3-Dichloropropane	ND	1	5	ug/Kg	08/06/10 NZ
1,4-Dichlorobenzene	ND	1	5	ug/Kg	08/06/10 NZ
2,2-Dichloropropane	ND	1	5	ug/Kg	08/06/10 NZ
2-Butanone (MEK)	ND	1	100	ug/Kg	08/06/10 NZ
2-Chloroethyl vinyl ether	ND	1	5	ug/Kg	08/06/10 NZ
2-Chlorotoluene	ND	1	5	ug/Kg	08/06/10 NZ
4-Chlorotoluene	ND	1	5	ug/Kg	08/06/10 NZ
4-Methyl -2- Pentanone (MIBK)	ND	1	5	ug/Kg	08/06/10 NZ
Acetone	ND	1	50	ug/Kg	08/06/10 NZ
Allyl chloride	ND	1	5	ug/Kg	08/06/10 NZ
Benzene	ND	1	5	ug/Kg	08/06/10 NZ
Bromobenzene	ND	1	5	ug/Kg	08/06/10 NZ
Bromochloromethane	ND	1	5	ug/Kg	08/06/10 NZ
Bromodichloromethane	ND	1	5	ug/Kg	08/06/10 NZ
Bromoform	ND	1	5	ug/Kg	08/06/10 NZ
Bromomethane	ND	1	5	ug/Kg	08/06/10 NZ
Carbon tetrachloride	ND	1	5	ug/Kg	08/06/10 NZ
Chlorobenzene	ND	1	5	ug/Kg	08/06/10 NZ
Chloroethane	ND	1	5	ug/Kg	08/06/10 NZ
Chloroform	ND	1	5	ug/Kg	08/06/10 NZ
Chloromethane	ND	1	5	ug/Kg	08/06/10 NZ
cis-1,2-Dichloroethene	ND	1	5	ug/Kg	08/06/10 NZ
cis-1,3-Dichloropropene	ND	1	5	ug/Kg	08/06/10 NZ
cis-1,4-Dichloro-2-butene	ND	1	5	ug/Kg	08/06/10 NZ
Dibromochloromethane	ND	1	5	ug/Kg	08/06/10 NZ
Dibromomethane	ND	1	5	ug/Kg	08/06/10 NZ
Dichlorodifluoromethane	ND	1	5	ug/Kg	08/06/10 NZ
Ethyl benzene	ND	1	5	ug/Kg	08/06/10 NZ
Hexachlorobutadiene	ND	1	5	ug/Kg	08/06/10 NZ
Isopropylbenzene (Cumene)	ND	1	5	ug/Kg	08/06/10 NZ
m and p-Xylene	ND	1	5	ug/Kg	08/06/10 NZ
Methyl-tert-butylether (MTBE)	ND	1	5	ug/Kg	08/06/10 NZ
Methylene chloride	ND	1	5	ug/Kg	08/06/10 NZ
n-Butylbenzene	ND	1	5	ug/Kg	08/06/10 NZ
n-Propylbenzene	ND	1	5	ug/Kg	08/06/10 NZ
Naphthalene	ND	1	5	ug/Kg	08/06/10 NZ
o-Xylene	ND	1	5	ug/Kg	08/06/10 NZ
p-Isopropyltoluene	ND	1	5	ug/Kg	08/06/10 NZ
sec-Butylbenzene	ND	1	5	ug/Kg	08/06/10 NZ

DLR = Detection limit for reporting purposes, ND = Not Detected below indicated detection limit, DF = Dilution Factor

**ASSOCIATED LABORATORIES**

Analytical Results Report



**ASSOCIATED LABORATORIES**

806 North Batavia • Orange, California 92868 • 714/771-6900  
 FAX 714/538-1209 • [www.associatedlabs.com](http://www.associatedlabs.com)

**TESTING & CONSULTING**

Chemical •  
 Microbiological •  
 Environmental •

**— INVOICE —**
**CUSTOMER:**

SABCO  
 Attn: James Stark  
 11220 Edison Hwy

Edison, CA 93220

Client ID: 13027

Inv. Date: 8/13/2010

Invoice # 404245

Lab Req. #: 258854

**TERMS: NET 30 DAYS**

Qty	Item	Item Amount	Item Total
3	9215 Aerobic Plate Count, Standard	11.00	\$33.00
3	Yeast & Mold (3 dilutions)	17.00	\$51.00

Total Balance Due \$84.00

To insure proper credit, please be sure to enclose invoice  
 number with your remittance. Thank you.

Order #: 1100716

Client: American Geotechnical

Matrix: SOLID

Client Sample ID: Laboratory Method Blank

Date Sampled:

Time Sampled:

Sampled By:

Analyte	Result	DF	DLR	Units	Date/Analyst
<b>8260B Volatile Organic Compounds</b>					
Styrene	ND	1	5	ug/Kg	08/06/10 NZ
tert-Butylbenzene	ND	1	5	ug/Kg	08/06/10 NZ
Tetrachloroethene	ND	1	5	ug/Kg	08/06/10 NZ
Toluene	ND	1	5	ug/Kg	08/06/10 NZ
trans-1,2-Dichloroethene	ND	1	5	ug/Kg	08/06/10 NZ
trans-1,3-Dichloropropene	ND	1	5	ug/Kg	08/06/10 NZ
trans-1,4-Dichloro-2-butene	ND	1	5	ug/Kg	08/06/10 NZ
Trichloroethene	ND	1	5	ug/Kg	08/06/10 NZ
Trichlorofluoromethane	ND	1	5	ug/Kg	08/06/10 NZ
Vinyl chloride	ND	1	5	ug/Kg	08/06/10 NZ
Xylenes, total	ND	1	5	ug/Kg	08/06/10 NZ
Di-isopropyl ether (DIPE)	ND	1	2.0	ug/Kg	08/06/10 NZ
Ethyl-tertbutylether (ETBE)	ND	1	2.0	ug/Kg	08/06/10 NZ
Tert-amylmethylether (TAME)	ND	1	2.0	ug/Kg	08/06/10 NZ
Tertiary butyl alcohol (TBA)	ND	1	10	ug/Kg	08/06/10 NZ

**Surrogates**

			Units	Control Limits
Surr1 - Dibromofluoromethane	101		%	70 - 135
Surr2 - 1,2-Dichloroethane-d4	101		%	70 - 135
Surr3 - Toluene-d8	106		%	70 - 135
Surr4 - p-Bromofluorobenzene	100		%	70 - 135

**8270C Acid/Base/Neutral Extractables**

1,2,4-Trichlorobenzene	ND	1	300	ug/Kg	08/09/10 SD
1,2-Dichlorobenzene	ND	1	300	ug/Kg	08/09/10 SD
1,3-Dichlorobenzene	ND	1	300	ug/Kg	08/09/10 SD
1,4-Dichlorobenzene	ND	1	300	ug/Kg	08/09/10 SD
2,4,5-Trichlorophenol	ND	1	300	ug/Kg	08/09/10 SD
2,4,6-Trichlorophenol	ND	1	300	ug/Kg	08/09/10 SD
2,4-Dichlorophenol	ND	1	300	ug/Kg	08/09/10 SD
2,4-Dimethylphenol	ND	1	300	ug/Kg	08/09/10 SD
2,4-Dinitrophenol	ND	1	300	ug/Kg	08/09/10 SD
2,4-Dinitrotoluene	ND	1	300	ug/Kg	08/09/10 SD
2,6-Dinitrotoluene	ND	1	300	ug/Kg	08/09/10 SD
2-Chloronaphthalene	ND	1	300	ug/Kg	08/09/10 SD
2-Chlorophenol	ND	1	300	ug/Kg	08/09/10 SD
2-Methylnaphthalene	ND	1	300	ug/Kg	08/09/10 SD
2-Methylphenol	ND	1	300	ug/Kg	08/09/10 SD

DLR = Detection limit for reporting purposes, ND = Not Detected below indicated detection limit, DF = Dilution Factor

**ASSOCIATED LABORATORIES**

Analytical Results Report





Order #: 1100716

Client: American Geotechnical

Matrix: SOLID

Client Sample ID: Laboratory Method Blank

Date Sampled:

Time Sampled:

Sampled By:

Analyte	Result	DF	DLR	Units	Date/Analyst
<b>8270C Acid/Base/Neutral Extractables</b>					
2-Nitroaniline	ND	1	300	ug/Kg	08/09/10 SD
2-Nitrophenol	ND	1	300	ug/Kg	08/09/10 SD
3,3-Dichlorobenzidine	ND	1	300	ug/Kg	08/09/10 SD
3-Methylphenol	ND	1	500	ug/Kg	08/09/10 SD
3-Nitroaniline	ND	1	300	ug/Kg	08/09/10 SD
4,6-Dinitro-2-methylphenol	ND	1	300	ug/Kg	08/09/10 SD
4-Bromophenyl-phenylether	ND	1	300	ug/Kg	08/09/10 SD
4-Chloro-3-methylphenol	ND	1	300	ug/Kg	08/09/10 SD
4-Chloroaniline	ND	1	300	ug/Kg	08/09/10 SD
4-Chlorophenyl-phenylether	ND	1	300	ug/Kg	08/09/10 SD
4-Methylphenol	ND	1	500	ug/Kg	08/09/10 SD
4-Nitroaniline	ND	1	300	ug/Kg	08/09/10 SD
4-Nitrophenol	ND	1	300	ug/Kg	08/09/10 SD
Acenaphthene	ND	1	300	ug/Kg	08/09/10 SD
Acenaphthylene	ND	1	300	ug/Kg	08/09/10 SD
Anthracene	ND	1	300	ug/Kg	08/09/10 SD
Benzidine	ND	1	1500	ug/Kg	08/09/10 SD
Benzo(a)anthracene	ND	1	300	ug/Kg	08/09/10 SD
Benzo(a)pyrene	ND	1	300	ug/Kg	08/09/10 SD
Benzo(b)fluoranthene	ND	1	300	ug/Kg	08/09/10 SD
Benzo(g,h,i)perylene	ND	1	300	ug/Kg	08/09/10 SD
Benzo(k)fluoranthene	ND	1	300	ug/Kg	08/09/10 SD
Benzoic Acid	ND	1	300	ug/Kg	08/09/10 SD
Benzyl alcohol	ND	1	300	ug/Kg	08/09/10 SD
bis(2-Chloroethoxy)methane	ND	1	300	ug/Kg	08/09/10 SD
bis(2-Chloroethyl)ether	ND	1	300	ug/Kg	08/09/10 SD
bis(2-Chloroisopropyl) ether	ND	1	300	ug/Kg	08/09/10 SD
bis(2-Ethylhexyl)phthalate	ND	1	300	ug/Kg	08/09/10 SD
Butylbenzylphthalate	ND	1	300	ug/Kg	08/09/10 SD
Chrysene	ND	1	300	ug/Kg	08/09/10 SD
Di-n-butylphthalate	ND	1	300	ug/Kg	08/09/10 SD
Di-n-octylphthalate	ND	1	300	ug/Kg	08/09/10 SD
Dibenz(a,h)anthracene	ND	1	300	ug/Kg	08/09/10 SD
Dibenzofuran	ND	1	300	ug/Kg	08/09/10 SD
Diethylphthalate	ND	1	300	ug/Kg	08/09/10 SD
Dimethylphthalate	ND	1	300	ug/Kg	08/09/10 SD
Fluoranthene	ND	1	300	ug/Kg	08/09/10 SD
Fluorene	ND	1	300	ug/Kg	08/09/10 SD
Hexachlorobenzene	ND	1	300	ug/Kg	08/09/10 SD

DLR = Detection limit for reporting purposes, ND = Not Detected below indicated detection limit, DF = Dilution Factor

ASSOCIATED LABORATORIES

Analytical Results Report



Order #: 1100716

Client: American Geotechnical

Matrix: SOLID

Client Sample ID: Laboratory Method Blank

Date Sampled:

Time Sampled:

Sampled By:

Analyte	Result	DF	DLR	Units	Date/Analyst
<b>8270C Acid/Base/Neutral Extractables</b>					
Hexachlorobutadiene	ND	1	300	ug/Kg	08/09/10 SD
Hexachlorocyclopentadiene	ND	1	300	ug/Kg	08/09/10 SD
Hexachloroethane	ND	1	300	ug/Kg	08/09/10 SD
Indeno(1,2,3-c,d)pyrene	ND	1	300	ug/Kg	08/09/10 SD
Isophorone	ND	1	300	ug/Kg	08/09/10 SD
N-Nitroso-di-n-propylamine	ND	1	300	ug/Kg	08/09/10 SD
N-Nitrosodiphenylamine	ND	1	300	ug/Kg	08/09/10 SD
Naphthalene	ND	1	300	ug/Kg	08/09/10 SD
Nitrobenzene	ND	1	300	ug/Kg	08/09/10 SD
Pentachlorophenol	ND	1	300	ug/Kg	08/09/10 SD
Phenanthrene	ND	1	300	ug/Kg	08/09/10 SD
Phenol	ND	1	300	ug/Kg	08/09/10 SD
Pyrene	ND	1	300	ug/Kg	08/09/10 SD

**Surrogates**

			Units	Control Limits
2,4,6-Tribromophenol (sur)	77		%	17 - 122
2-Fluorobiphenyl (sur)	91		%	30 - 115
2-Fluorophenol (sur)	87		%	25 - 121
Nitrobenzene-d5 (sur)	80		%	23 - 120
Phenol-d5 (sur)	84		%	24 - 113
Terphenyl-d14 (sur)	91		%	18 - 137

**8015B - Gasoline**

Gasoline	ND	1	3	mg/Kg	08/05/10 LT
<b>Surrogates</b>					
p-Bromofluorobenzene (Sur)	129			%	60 - 140

DLR = Detection limit for reporting purposes, ND = Not Detected below indicated detection limit, DF = Dilution Factor

**ASSOCIATED LABORATORIES**

Analytical Results Report



Order #: 1100717

Client: American Geotechnical

Matrix: WATER

Client Sample ID: Laboratory Method Blank

Date Sampled:

Time Sampled:

Sampled By:

Analyte	Result	DF	DLR	Units	Date/Analyst
<b>6010B ICP CAM Metals Only (W/S/W)</b>					
Antimony	ND	1	0.020	mg/L	08/06/10 KN
Arsenic	ND	1	0.010	mg/L	08/06/10 KN
Barium	ND	1	0.010	mg/L	08/06/10 KN
Beryllium	ND	1	0.005	mg/L	08/06/10 KN
Cadmium	ND	1	0.005	mg/L	08/06/10 KN
Chromium	ND	1	0.010	mg/L	08/06/10 KN
Cobalt	ND	1	0.005	mg/L	08/06/10 KN
Copper	ND	1	0.010	mg/L	08/06/10 KN
Lead	ND	1	0.005	mg/L	08/06/10 KN
Molybdenum	ND	1	0.010	mg/L	08/06/10 KN
Nickel	ND	1	0.020	mg/L	08/06/10 KN
Selenium	ND	1	0.010	mg/L	08/06/10 KN
Silver	ND	1	0.005	mg/L	08/06/10 KN
Thallium	ND	1	0.005	mg/L	08/06/10 KN
Vanadium	ND	1	0.005	mg/L	08/06/10 KN
Zinc	ND	1	0.020	mg/L	08/06/10 KN

**7470A Mercury in Water**

Mercury	ND	1	0.0004	mg/L	08/06/10 NF
---------	----	---	--------	------	-------------

**8015 TEPH Diesel**

TEPH Diesel	ND	1	0.1	mg/L	08/09/10 AF
-------------	----	---	-----	------	-------------

**Surrogates**

				Units	Control Limits
Triacotane (Sur)	122			%	60 - 140

**8081A - Organochlorine Pesticides by GC**

4,4-DDD	ND	1	0.06	ug/L	08/05/10 GH
4,4-DDE	ND	1	0.05	ug/L	08/05/10 GH
4,4-DDT	ND	1	0.06	ug/L	08/05/10 GH
Aldrin	ND	1	0.11	ug/L	08/05/10 GH
Alpha BHC	ND	1	0.04	ug/L	08/05/10 GH
Beta BHC	ND	1	0.03	ug/L	08/05/10 GH
Chlordane	ND	1	0.25	ug/L	08/05/10 GH

DLR = Detection limit for reporting purposes, ND = Not Detected below indicated detection limit, DF = Dilution Factor

**ASSOCIATED LABORATORIES**

Analytical Results Report



Order #: 1100717

Client: American Geotechnical

Matrix: WATER

Client Sample ID: Laboratory Method Blank

Date Sampled:

Time Sampled:

Sampled By:

Analyte	Result	DF	DLR	Units	Date/Analyst
---------	--------	----	-----	-------	--------------

**8081A - Organochlorine Pesticides by GC**

Delta BHC	ND	1	0.03	ug/L	08/05/10 GH
Dieldrin	ND	1	0.06	ug/L	08/05/10 GH
Endosulfan I	ND	1	0.03	ug/L	08/05/10 GH
Endosulfan II	ND	1	0.06	ug/L	08/05/10 GH
Endosulfan sulfate	ND	1	0.06	ug/L	08/05/10 GH
Endrin	ND	1	0.06	ug/L	08/05/10 GH
Endrin aldehyde	ND	1	0.13	ug/L	08/05/10 GH
Endrin Ketone	ND	1	0.05	ug/L	08/05/10 GH
Heptachlor	ND	1	0.08	ug/L	08/05/10 GH
Heptachlor epoxide	ND	1	0.05	ug/L	08/05/10 GH
Lindane	ND	1	0.03	ug/L	08/05/10 GH
Methoxychlor	ND	1	0.57	ug/L	08/05/10 GH
Toxaphene	ND	1	3.13	ug/L	08/05/10 GH

**Surrogates**

				Units	Control Limits
DCB(Sur2)	117			%	55 - 130
TCMX (Sur1)	91			%	50 - 125

**8260B Volatile Organic Compounds**

1,1,1,2-Tetrachloroethane	ND	1	5	ug/L	08/07/10 LZ
1,1,1-Trichloroethane	ND	1	5	ug/L	08/07/10 LZ
1,1,2,2-Tetrachloroethane	ND	1	5	ug/L	08/07/10 LZ
1,1,2-Trichloroethane	ND	1	5	ug/L	08/07/10 LZ
1,1,2-Trichlorotrifluoroethane	ND	1	5	ug/L	08/07/10 LZ
1,1-Dichloroethane	ND	1	5	ug/L	08/07/10 LZ
1,1-Dichloroethene	ND	1	5	ug/L	08/07/10 LZ
1,1-Dichloropropene	ND	1	5	ug/L	08/07/10 LZ
1,2,3-Trichlorobenzene	ND	1	5	ug/L	08/07/10 LZ
1,2,3-Trichloropropane	ND	1	5	ug/L	08/07/10 LZ
1,2,4-Trichlorobenzene	ND	1	5	ug/L	08/07/10 LZ
1,2,4-Trimethylbenzene	ND	1	5	ug/L	08/07/10 LZ
1,2-Dibromo-3-chloropropane	ND	1	5	ug/L	08/07/10 LZ
1,2-Dibromoethane	ND	1	5	ug/L	08/07/10 LZ
1,2-Dichlorobenzene	ND	1	5	ug/L	08/07/10 LZ
1,2-Dichloroethane	ND	1	5	ug/L	08/07/10 LZ
1,2-Dichloropropane	ND	1	5	ug/L	08/07/10 LZ
1,3,5-Trimethylbenzene	ND	1	5	ug/L	08/07/10 LZ
1,3-Dichlorobenzene	ND	1	5	ug/L	08/07/10 LZ

DLR = Detection limit for reporting purposes, ND = Not Detected below indicated detection limit, DF = Dilution Factor

**ASSOCIATED LABORATORIES**

Analytical Results Report



Order #: 1100717

Client: American Geotechnical

Matrix: WATER

Client Sample ID: Laboratory Method Blank

Date Sampled:

Time Sampled:

Sampled By:

Analyte	Result	DF	DLR	Units	Date/Analyst
<b>8260B Volatile Organic Compounds</b>					
1,3-Dichloropropane	ND	1	5	ug/L	08/07/10 LZ
1,4-Dichlorobenzene	ND	1	5	ug/L	08/07/10 LZ
2,2-Dichloropropane	ND	1	5	ug/L	08/07/10 LZ
2-Butanone (MEK)	ND	1	100	ug/L	08/07/10 LZ
2-Chloroethyl vinyl ether	ND	1	5	ug/L	08/07/10 LZ
2-Chlorotoluene	ND	1	5	ug/L	08/07/10 LZ
4-Chlorotoluene	ND	1	5	ug/L	08/07/10 LZ
4-Methyl -2- Pentanone (MIBK)	ND	1	10	ug/L	08/07/10 LZ
Acetone	ND	1	100	ug/L	08/07/10 LZ
Allyl chloride	ND	1	5	ug/L	08/07/10 LZ
Benzene	ND	1	1	ug/L	08/07/10 LZ
Bromobenzene	ND	1	5	ug/L	08/07/10 LZ
Bromochloromethane	ND	1	5	ug/L	08/07/10 LZ
Bromodichloromethane	ND	1	5	ug/L	08/07/10 LZ
Bromoform	ND	1	5	ug/L	08/07/10 LZ
Bromomethane	ND	1	5	ug/L	08/07/10 LZ
Carbon tetrachloride	ND	1	5	ug/L	08/07/10 LZ
Chlorobenzene	ND	1	5	ug/L	08/07/10 LZ
Chloroethane	ND	1	5	ug/L	08/07/10 LZ
Chloroform	ND	1	5	ug/L	08/07/10 LZ
Chloromethane	ND	1	5	ug/L	08/07/10 LZ
cis-1,2-Dichloroethene	ND	1	5	ug/L	08/07/10 LZ
cis-1,3-Dichloropropene	ND	1	5	ug/L	08/07/10 LZ
cis-1,4-Dichloro-2-butene	ND	1	20	ug/L	08/07/10 LZ
Dibromochloromethane	ND	1	5	ug/L	08/07/10 LZ
Dibromomethane	ND	1	5	ug/L	08/07/10 LZ
Dichlorodifluoromethane	ND	1	5	ug/L	08/07/10 LZ
Ethyl benzene	ND	1	5	ug/L	08/07/10 LZ
Hexachlorobutadiene	ND	1	5	ug/L	08/07/10 LZ
Isopropylbenzene (Cumene)	ND	1	5	ug/L	08/07/10 LZ
m and p-Xylene	ND	1	5	ug/L	08/07/10 LZ
Methyl-tert-butylether (MTBE)	ND	1	1	ug/L	08/07/10 LZ
Methylene chloride	ND	1	5	ug/L	08/07/10 LZ
n-Butylbenzene	ND	1	5	ug/L	08/07/10 LZ
n-Propylbenzene	ND	1	5	ug/L	08/07/10 LZ
Naphthalene	ND	1	5	ug/L	08/07/10 LZ
o-Xylene	ND	1	5	ug/L	08/07/10 LZ
p-Isopropyltoluene	ND	1	5	ug/L	08/07/10 LZ
sec-Butylbenzene	ND	1	5	ug/L	08/07/10 LZ

DLR = Detection limit for reporting purposes, ND = Not Detected below indicated detection limit, DF = Dilution Factor

**ASSOCIATED LABORATORIES**

Analytical Results Report



Order #: 1100717

Client: American Geotechnical

Matrix: WATER

Client Sample ID: Laboratory Method Blank

Date Sampled:

Time Sampled:

Sampled By:

Analyte	Result	DF	DLR	Units	Date/Analyst
<b>8260B Volatile Organic Compounds</b>					
Styrene	ND	1	5	ug/L	08/07/10 LZ
tert-Butylbenzene	ND	1	5	ug/L	08/07/10 LZ
Tetrachloroethene	ND	1	5	ug/L	08/07/10 LZ
Toluene	ND	1	5	ug/L	08/07/10 LZ
trans-1,2-Dichloroethene	ND	1	5	ug/L	08/07/10 LZ
trans-1,3-Dichloropropene	ND	1	5	ug/L	08/07/10 LZ
trans-1,4-Dichloro-2-butene	ND	1	20	ug/L	08/07/10 LZ
Trichloroethene	ND	1	5	ug/L	08/07/10 LZ
Trichlorofluoromethane	ND	1	5	ug/L	08/07/10 LZ
Vinyl chloride	ND	1	5	ug/L	08/07/10 LZ
Xylenes, total	ND	1	5	ug/L	08/07/10 LZ
Di-isopropyl ether (DIPE)	ND	1	1.0	ug/L	08/07/10 LZ
Ethyl-tertbutylether (ETBE)	ND	1	1.0	ug/L	08/07/10 LZ
Tert-amylmethylether (TAME)	ND	1	1.0	ug/L	08/07/10 LZ
Tertiary butyl alcohol (TBA)	ND	1	10	ug/L	08/07/10 LZ

**Surrogates**

			Units	Control Limits
Surr1 - Dibromofluoromethane	81		%	70 - 135
Surr2 - 1,2-Dichloroethane-d4	112		%	70 - 135
Surr3 - Toluene-d8	96		%	70 - 135
Surr4 - p-Bromofluorobenzene	95		%	70 - 135

**8270C Acid/Base/Neutral Extractables**

1,2,4-Trichlorobenzene	ND	1	10	ug/L	08/08/10 SD
1,2-Dichlorobenzene	ND	1	10	ug/L	08/08/10 SD
1,3-Dichlorobenzene	ND	1	10	ug/L	08/08/10 SD
1,4-Dichlorobenzene	ND	1	10	ug/L	08/08/10 SD
2,4,5-Trichlorophenol	ND	1	10	ug/L	08/08/10 SD
2,4,6-Trichlorophenol	ND	1	10	ug/L	08/08/10 SD
2,4-Dichlorophenol	ND	1	10	ug/L	08/08/10 SD
2,4-Dimethylphenol	ND	1	10	ug/L	08/08/10 SD
2,4-Dinitrophenol	ND	1	10	ug/L	08/08/10 SD
2,4-Dinitrotoluene	ND	1	10	ug/L	08/08/10 SD
2,6-Dinitrotoluene	ND	1	10	ug/L	08/08/10 SD
2-Chloronaphthalene	ND	1	10	ug/L	08/08/10 SD
2-Chlorophenol	ND	1	10	ug/L	08/08/10 SD
2-Methylnaphthalene	ND	1	10	ug/L	08/08/10 SD
2-Methylphenol	ND	1	10	ug/L	08/08/10 SD

DLR = Detection limit for reporting purposes, ND = Not Detected below indicated detection limit, DF = Dilution Factor

**ASSOCIATED LABORATORIES**

Analytical Results Report



Order #: 1100717

Client: American Geotechnical

Matrix: WATER

Client Sample ID: Laboratory Method Blank

Date Sampled:

Time Sampled:

Sampled By:

Analyte	Result	DF	DLR	Units	Date/Analyst
<b>8270C Acid/Base/Neutral Extractables</b>					
2-Nitroaniline	ND	1	50	ug/L	08/08/10 SD
2-Nitrophenol	ND	1	10	ug/L	08/08/10 SD
3,3-Dichlorobenzidine	ND	1	10	ug/L	08/08/10 SD
3-Methylphenol	ND	1	10	ug/L	08/08/10 SD
3-Nitroaniline	ND	1	10	ug/L	08/08/10 SD
4,6-Dinitro-2-methylphenol	ND	1	10	ug/L	08/08/10 SD
4-Bromophenyl-phenylether	ND	1	10	ug/L	08/08/10 SD
4-Chloro-3-methylphenol	ND	1	10	ug/L	08/08/10 SD
4-Chloroaniline	ND	1	10	ug/L	08/08/10 SD
4-Chlorophenyl-phenylether	ND	1	10	ug/L	08/08/10 SD
4-Methylphenol	ND	1	10	ug/L	08/08/10 SD
4-Nitroaniline	ND	1	10	ug/L	08/08/10 SD
4-Nitrophenol	ND	1	10	ug/L	08/08/10 SD
Acenaphthene	ND	1	10	ug/L	08/08/10 SD
Acenaphthylene	ND	1	10	ug/L	08/08/10 SD
Anthracene	ND	1	10	ug/L	08/08/10 SD
Benzidine	ND	1	10	ug/L	08/08/10 SD
Benzo(a)anthracene	ND	1	10	ug/L	08/08/10 SD
Benzo(a)pyrene	ND	1	10	ug/L	08/08/10 SD
Benzo(b)fluoranthene	ND	1	10	ug/L	08/08/10 SD
Benzo(g,h,i)perylene	ND	1	10	ug/L	08/08/10 SD
Benzo(k)fluoranthene	ND	1	10	ug/L	08/08/10 SD
Benzoic Acid	ND	1	10	ug/L	08/08/10 SD
Benzyl alcohol	ND	1	10	ug/L	08/08/10 SD
bis(2-Chloroethoxy)methane	ND	1	10	ug/L	08/08/10 SD
bis(2-Chloroethyl)ether	ND	1	10	ug/L	08/08/10 SD
bis(2-Chloroisopropyl) ether	ND	1	10	ug/L	08/08/10 SD
bis(2-Ethylhexyl)phthalate	ND	1	10	ug/L	08/08/10 SD
Butylbenzylphthalate	ND	1	10	ug/L	08/08/10 SD
Chrysene	ND	1	10	ug/L	08/08/10 SD
Di-n-butylphthalate	ND	1	10	ug/L	08/08/10 SD
Di-n-octylphthalate	ND	1	10	ug/L	08/08/10 SD
Dibenz(a,h)anthracene	ND	1	10	ug/L	08/08/10 SD
Dibenzofuran	ND	1	10	ug/L	08/08/10 SD
Diethylphthalate	ND	1	10	ug/L	08/08/10 SD
Dimethylphthalate	ND	1	10	ug/L	08/08/10 SD
Fluoranthene	ND	1	10	ug/L	08/08/10 SD
Fluorene	ND	1	10	ug/L	08/08/10 SD
Hexachlorobenzene	ND	1	10	ug/L	08/08/10 SD

DLR = Detection limit for reporting purposes, ND = Not Detected below indicated detection limit, DF = Dilution Factor

**ASSOCIATED LABORATORIES**

Analytical Results Report



Order #: 1100717

Client: American Geotechnical

Matrix: WATER

Client Sample ID: Laboratory Method Blank

Date Sampled:

Time Sampled:

Sampled By:

Analyte	Result	DF	DLR	Units	Date/Analyst
<b>8270C Acid/Base/Neutral Extractables</b>					
Hexachlorobutadiene	ND	1	10	ug/L	08/08/10 SD
Hexachlorocyclopentadiene	ND	1	10	ug/L	08/08/10 SD
Hexachloroethane	ND	1	10	ug/L	08/08/10 SD
Indeno(1,2,3-c,d)pyrene	ND	1	10	ug/L	08/08/10 SD
Isophorone	ND	1	10	ug/L	08/08/10 SD
N-Nitroso-di-n-propylamine	ND	1	10	ug/L	08/08/10 SD
N-Nitrosodiphenylamine	ND	1	10	ug/L	08/08/10 SD
Naphthalene	ND	1	10	ug/L	08/08/10 SD
Nitrobenzene	ND	1	10	ug/L	08/08/10 SD
Pentachlorophenol	ND	1	10	ug/L	08/08/10 SD
Phenanthrene	ND	1	10	ug/L	08/08/10 SD
Phenol	ND	1	10	ug/L	08/08/10 SD
Pyrene	ND	1	10	ug/L	08/08/10 SD

Surrogates		Units	Control Limits
2,4,6-Tribromophenol (sur)	76	%	10 - 123
2-Fluorobiphenyl (sur)	74	%	43 - 116
2-Fluorophenol (sur)	53	%	21 - 110
Nitrobenzene-d5 (sur)	52	%	34 - 114
Phenol-d5 (sur)	37	%	10 - 110
Terphenyl-d14 (sur)	85	%	33 - 141

**8015B - Gasoline**

Gasoline	ND	1	50	ug/L	08/05/10 LT
<b>Surrogates</b>					
p-Bromofluorobenzene (Sur)	101			%	60 - 140

DLR = Detection limit for reporting purposes, ND = Not Detected below indicated detection limit, DF = Dilution Factor

**ASSOCIATED LABORATORIES**

Analytical Results Report





ASSOCIATED LABORATORIES  
**QA REPORT FORM - METHOD 6010**

QC Sample: 256811-1088738 H# 080510SO1  
 Matrix: SOLID  
 Prep. Date: August 5, 2010  
 Analysis Date: August 6, 2010  
 Lab ID#'s in Batch: 256811, 259143, 259142

Reporting Units = mg/Kg

**MATRIX SPIKE / MATRIX SPIKE DUPLICATE RESULT**

Test	Sample Result	Spike Added	Matrix Spike	Matrix Spike Dup	%Rec MS	%Rec MSD	% RPD
As	1.460	97.0	95.00	89.00	96	90	7
Se	ND	97.0	102.00	95.00	105	98	7
Tl	ND	97.0	107.00	100.00	110	103	7
Pb	2.370	97.0	104.00	93.00	105	93	11
Sb	ND	97.0	101.00	93.00	104	96	8
Ba	16.800	97.0	118.00	110.00	104	96	7
Be	ND	97.0	107.00	99.00	110	102	8
Cd	ND	97.0	98.00	91.00	101	94	7
Cr	15.500	97.0	118.00	114.00	106	102	3
Co	3.490	97.0	103.00	96.00	103	95	7
Cu	2.150	97.0	100.00	104.00	101	105	4
Mo	1.410	97.0	97.00	91.00	99	92	6
Ni	6.750	97.0	106.00	99.00	102	95	7
Ag*	ND	48.0	40.00	33.00	83	69	19
V	24.800	97.0	126.00	116.00	104	94	8
Zn	10.800	97.0	109.00	103.00	101	95	6

\* = Outside QC Limits, Due to Matrix Interference  
 If Sample Result > 4 Times Spike Added, Then "NC"

% REC LIMITS = 75 -125 RPD LIMITS = 20
---

ASSOCIATED LABORATORIES  
LCS REPORT FORM - METHOD 6010

**LCS RECOVERY / METHOD BLANK**

Test	LCS Result	True Value	LCS %Rec	QC Limit %REC	Method Blank
Ag	102.00	100	102	80-120	< 0.5
As	191.00	200	96	80-120	< 1
Ba	212.00	200	106	80-120	< 1
Be	220.00	200	110	80-120	< 0.5
Cd	206.00	200	103	80-120	< 0.5
Co	208.00	200	104	80-120	< 0.5
Cr	216.00	200	108	80-120	< 1
Cu	203.00	200	102	80-120	< 1
Mo	199.00	200	100	80-120	< 1
Ni	209.00	200	105	80-120	< 1.5
Pb	211.00	200	106	80-120	< 0.5
Sb	209.00	200	105	80-120	< 3
Se	216.00	200	108	80-120	< 1
Tl	228.00	200	114	80-120	< 1
V	210.00	200	105	80-120	< 0.5
Zn	210.00	200	105	80-120	< 5

ASSOCIATED LABORATORIES  
QA REPORT FORM

QC Sample: 256811-1088738

Matrix: SOIL

Prep. Date: August 6, 2010

Analysis Date: August 6, 2010

Lab ID#'s in Batch: 256811, 259142

**MATRIX SPIKE / MATRIX SPIKE DUPLICATE RESULT**

Reporting Units = mg/Kg

Test	Method	Sample Result	Spike Added	Matrix Spike	Matrix Spike Dup	%Rec MS	%Rec MSD	RPD
MERCURY	7471	ND	0.83	0.82	0.82	99	99	0

RPD = Relative Percent Difference of Matrix Spike and Matrix Spike Duplicate  
%REC-MS & MSD = Percent Recovery of Matrix Spike & Matrix Spike Duplicate

%REC LIMIT 75-125
RPD LIMITS = 20

**PREPARATION BLANK / LAB CONTROL SAMPLE RESULTS**

PREP BLK/LCS-2					
Value	Result	True	%Rec	L.Limit	H.Limit
ND	0.85	0.83	103	80%	120%

Value = Preparation Blank Value; ND = Not-Detected  
LCS Result = Lab Control Sample Result  
True = True Value of LCS  
L.Limit / H.Limit = LCS Control Limits

**ASSOCIATED LABORATORIES  
LCS REPORT FORM**

QC Sample: LCS/LCSD

Matrix: WATER

Extraction Method : 3510C

Prep. Date: August 6, 2010

Analysis Date August 9, 2010

Lab ID#'s in Batch: LR259142, 259200

**LAB CONTROLLED SPIKE / LAB CONTROLLED DUPLICATE RESULT**

Reporting Units = mg/L

Test	Method	Method Blank	Spike Added	LCS Spike	LCSD Spk. Dup	%Rec LCS	%Rec LCSD	RPD
DIESEL	8015B	ND	1.0	0.78	0.78	75	75	0

*ND = Not Detected*

*LCS Result = Lab Control Sample Result*

*%REC-LCS & LCSD = Percent Recovery of LCS Spike & LCS Spike Duplicate*

*RPD = Relative Percent Difference of LCS Spike and LCS Spike Duplicate*

<i>%REC LIMITS = 60 - 140</i>
<i>RPD LIMITS = 30</i>

**SURROGATE RECOVERY**

Sample No.	n-triacontane-d62
QC Limit	60-140
Method Blank	122
LCS	78
LCSD	92

**ASSOCIATED LABORATORIES  
LCS REPORT FORM**

QC Sample: LCS/LCSD

Matrix: SOLID

Extraction Method : 3545

Prep. Date: August 5, 2010

Analysis Date August 5, 2010

Lab ID#'s in Batch: LR256811, 259129, 259130, 259142

**LAB CONTROLLED SPIKE / LAB CONTROLLED DUPLICATE RESULT**

Reporting Units = mg/Kg

Test	Method	Method Blank	Spike Added	LCS Spike	LCSD Spk. Dup	%Rec LCS	%Rec LCSD	RPD
DIESEL	8015D	ND	25.0	20.3	24.5	81	98	19

*ND = Not Detected*

*LCS Result = Lab Control Sample Result*

*%REC-LCS & LCSD = Percent Recovery of LCS Spike & LCS Spike Duplicate*

*RPD = Relative Percent Difference of LCS Spike and LCS Spike Duplicate*

<i>%REC LIMITS = 70 - 130</i>
-------------------------------

<i>RPD LIMITS = 30</i>
------------------------

**SURROGATE RECOVERY**

Sample No.	surr
QC Limit	60-140
Method Blank	83
LCS	80
LCSD	80

# ASSOCIATED LABORATORIES

## QA REPORT FORM

Determinative Method : EPA 8081 / 608                      Preparative Method: EPA 3510

QC Sample: 206206-870301

Matrix: WATER

Analysis Date: 8/5/2010

Batch Date: 8/5/2010 (pest-080510w)

Applies to: LR 258888 & LR 259142

### MATRIX SPIKE / MATRIX SPIKE DUPLICATE RESULTS

REPORTING UNITS =  $\mu\text{g/L}$

Volumes=      750              760

Test	Sample Result	MS-Spike Added	MSD-Spike Added	Spike Recovered		% Rec		RPD	QC Limits	
				MS	MSD	MS	MSD		RPD	% Rec
gamma-BHC (Lindane)	ND	0.667	0.658	0.725	0.629	109	96	13	35	50-135
Heptachlor	ND	0.667	0.658	0.781	0.680	117	103	12	35	50-135
Aldrin	ND	0.667	0.658	0.643	0.563	96	86	12	35	50-135
Dieldrin	ND	0.667	0.658	0.790	0.674	118	102	15	35	50-135
Endrin	ND	0.667	0.658	0.837	0.716	126	109	14	35	50-135
DDT	ND	0.667	0.658	0.748	0.627	112	95	16	35	50-135

\* *Outside Control Limits due to matrix interference*

ND = Not Detected

% Rec - MS & MSD = Percent Recovery from Matrix Spike & Matrix Spike Duplicate

RPD = Relative Percent Difference of Matrix Spike and Matrix Spike Duplicate recoveries

### LAB CONTROL SPIKE / LAB CONTROL SPIKE DUPLICATE RESULTS

REPORTING UNITS =  $\mu\text{g/L}$

Test	Spike Added	Spike Recovered		% Rec		RPD	QC Limits	
		LCS	LCSD	LCS	LCSD		RPD	% Rec
gamma-BHC (Lindane)	0.50	0.530	0.512	106	102	3	35	55-130
Heptachlor	0.50	0.564	0.540	113	108	4	35	55-130
Aldrin	0.50	0.459	0.438	92	88	5	35	55-130
Dieldrin	0.50	0.605	0.568	121	114	6	35	55-130
Endrin	0.50	0.644	0.602	129	120	7	35	55-130
DDT	0.50	0.577	0.548	115	110	5	35	55-130

Method Blank = All Non-Detect

% Rec - LCS & LCSD = Percent Recovery from Lab Control Spike & Lab Control Spike Duplicate

RPD = Relative Percent Difference of Lab Control Spike & Lab Control Spike Duplicate recoveries

**ASSOCIATED LABORATORIES**

**QA / QC EPA Methods 8260, 624, & 524.2 GCMS # 8**

Sample ID: *MS/MSD Water Sample*

259085-557

Date Prepared: August 7, 2010

Date Analyzed: 8/7-8/8

Sample Matrix: Water

Units: µg/L

Lab ID#'s in Batch: LR259104, 259102, 259085, 258986, 259116, 259142, 259109, 259162, 259095

Compound	Sample Conc.	Spike Added	Spike Res	Dup Res	Spike % Rec	Dup % Rec	RPD	QC RPD	Limits % Rec
1,1-Dichloroethene	0.00	50.0	55.0	62.0	110	124	12	22	59 - 172
MTBE	0.00	50.0	45.5	55.1	91	110	19	24	62 - 137
Benzene	0.00	50.0	48.8	56.9	98	114	15	24	62 - 137
Trichloroethene	0.00	50.0	44.9	51.2	90	102	13	21	66 - 142
Toluene	0.00	50.0	46.8	54.7	94	109	16	21	59 - 139
Chlorobenzene	0.00	50.0	47.9	56.8	96	114	17	21	60 - 133

Sample ID: *LCS*

Compound	Spike Added	Spike Res	Spike % Rec	Limits % Rec
1,1-Dichloroethene	50.0	57.8	116	59 - 172
MTBE	50.0	51.6	103	62 - 137
Benzene	50.0	53.5	107	62 - 137
Trichloroethene	50.0	48.6	97	66 - 142
Toluene	50.0	52.6	105	59 - 139
Chlorobenzene	50.0	55.2	110	60 - 133

\*=Outside QC limits due to high concentration in sample  
If Sample Result > 4 times Spike Added, then "NC"

*Surrogate Recovery*

Compound	MB 1 % Rec	MB 2 % Rec	MS % Rec	MSD % Rec	LCS % Rec	Limits % Rec
Dibromofluoromethane	81	80	106	106	103	70 - 135
1,2-Dichloroethane-d4	112	107	96	97	91	70 - 135
Toluene-d8	96	95	96	98	97	70 - 135
p-Bromofluorobenzene	95	95	94	94	94	70 - 135

# ASSOCIATED LABORATORIES

## QA / QC EPA Methods 8260 - GCMS # 6

Sample ID: 259142-711  
 QC Batch ID: 8260MS#6-0728S  
 Prep Method: 5030  
 Date Prepared: August 6, 2010  
 Date Analyzed: 8/6-8/7/10  
 Sample Matrix: Solid  
 Units: µg/Kg

Lab ID#'s in Batch: 259142, 259543, 259203, 209111, 258950

Compound	Sample Conc.	Spike Added	Spike Res	Dup Res	Spike % Rec	Dup % Rec	RPD	QC RPD	Limits % Rec
1,1-Dichloroethene	0.00	50.0	49.7	51.4	99	103	3	22	59 - 172
MTBE	0.00	50.0	51.1	53.7	102	107	5	24	62 - 137
Benzene	0.00	50.0	47.9	49.1	96	98	2	24	62 - 137
Trichloroethene	0.00	50.0	51.8	51.6	104	103	0	21	66 - 142
Toluene	0.00	50.0	52.0	51.3	104	103	1	21	59 - 139
Chlorobenzene	0.00	50.0	52.6	54.7	105	109	4	21	60 - 133

Sample ID: LCS

Compound	Spike Added	Spike Res	Spike % Rec	Limits % Rec
1,1-Dichloroethene	50.0	44.6	89	59 - 172
MTBE	50.0	51.5	103	62 - 137
Benzene	50.0	43.3	87	62 - 137
Trichloroethene	50.0	46.4	93	66 - 142
Toluene	50.0	46.1	92	59 - 139
Chlorobenzene	50.0	47.9	96	60 - 133

\*=Outside QC limits due to high concentration in sample

If Sample Result > 4 times Spike Added, then "NC"

### Surrogate Recovery

Compound	MB 1 % Rec	MB 2 % Rec	MS % Rec	MSD % Rec	LCS % Rec	Limits % Rec
Dibromofluoromethane	101	96	103	103	102	70 - 135
1,2-Dichloroethane-d4	101	95	97	104	97	70 - 135
Toluene-d8	106	106	106	102	104	70 - 135
p-Bromofluorobenzene	100	101	89	94	94	70 - 135



**ASSOCIATED LABORATORIES**  
**QA REPORT FORM**

Method : EPA 8270

Preparative Method: EPA 3545

QC Sample: 259142-1100712

Matrix: SOLID

Date Analyzed : 8/9/2010

Batch Date: 8/06/2010 (8270-080610s)

Applies to: LR 259142; LR 258543

**MATRIX SPIKE / MATRIX SPIKE DUPLICATE RESULT**

REPORTING UNITS =  $\mu\text{g/Kg}$

Test	Sample Result	Spike Added	Matrix Spike	Matrix Spk. Dup	%Rec MS	%Rec MSD	RPD	QC Limits	
								RPD	%REC
Phenol	ND	2500	1522	1509	61	60	1	52	18-115
2-Chorophenol	ND	2500	1945	1913	78	77	2	58	26-90
1,4-Dichlorobenzene	ND	2500	1913	1918	77	77	0	81	13-93
N-Nitroso-di-N-propylamine	ND	2500	1428	1359	57	54	5	56	18-114
1,2,4-Trichlorobenzene	ND	2500	1978	2000	79	80	1	57	19-115
4-Chloro-3-methylphenol	ND	2500	1889	1856	76	74	2	34	29-115
Acenaphthene	ND	2500	2281	2320	91	93	2	50	17-114
4-Nitrophenol	ND	2500	1642	1453	66	58	12	45	3-115
2,4-Dinitrotoluene	ND	2500	2038	2194	82	88	7	30	40-115
Pentachlorophenol	ND	2500	1493	1612	60	64	8	41	0-146
Pyrene	ND	2500	2190	2273	88	91	4	37	26-141

\* Outside Control Limits due to matrix interference

ND = Not Detected

RPD = Relative Percent Difference of Matrix Spike and Matrix Spike Duplicate

% Rec-MS & MSD = Percent Recoveries from Matrix Spike & Matrix Spike Duplicate

**LCS RECOVERY / METHOD BLANK**

REPORTING UNITS =  $\mu\text{g/Kg}$

Test	Spike Added	LCS Result	LCS % Rec	Limits % Rec
Phenol	2500	1705	68	25-100
2-Chorophenol	2500	1865	75	19-100
1,4-Dichlorobenzene	2500	1949	78	16-100
N-Nitroso-di-N-propylamine	2500	1494	60	17-108
1,2,4-Trichlorobenzene	2500	2051	82	15-96
4-Chloro-3-methylphenol	2500	1909	76	27-100
Acenaphthene	2500	2471	99	23-109
4-Nitrophenol	2500	1650	66	7-104
2,4-Dinitrotoluene	2500	2250	90	45-105
Pentachlorophenol	2500	1491	60	11-107
Pyrene	2500	2239	90	45-130

Method Blank = All ND

**ASSOCIATED LABORATORIES  
QA REPORT FORM**

QC Sample: 259075-541-5.0ms

Batch # 8015g6 0805-S

Prep Method 5035

Matrix: SOLID

Prep. Date: August 5, 2010

Analysis Date: 8/5/10-8/6/10

Lab ID#'s in Batch: 256811 , 259075 , 259142 .

Reporting Units = mg/Kg

**MATRIX SPIKE / MATRIX SPIKE DUPLICATE RESULT**

Test	Method	Sample Result	Spike Added	Matrix Spike	Matrix Spike Dup	%Rec MS	%Rec MSD	RPD	QC Limits	
									RPD	%REC
TPH	8015B	ND	5.0	5.0	5.0	100	100	0	30	70-130

**LAB CONTROLLED SPIKE**

Test	Method	Method	Spike	LCS	%Rec	QC Limits
		Blank	Added	Spike	LCS	%REC
TPH	8015B	ND	5.0	5.1	102	80-120

**SURROGATE RECOVERY**

Sample No.	Surrogate BFB
QC Limit	60-140
QA Sample	129
MS	129
MSD	139
Method Blank	129
LCS	140

BFB = p Bromofluorobenzen

**ASSOCIATED LABORATORIES**  
**QA REPORT FORM**

Method : EPA 8270 Preparative Method: EPA 3510

QC Sample: LCS / LCSD

Matrix: WATER

Date Analyzed : 8/9/2010

Batch Date: 8/6/10 (8270-080610-w)

Applies to: LR 258986, LR 259142

**LAB CONTROL SPIKE / LAB CONTROL SPIKE DUPLICATE RESULTS**

REPORTING UNITS =  $\mu\text{g/L}$

Test	Spike Added	Spike Recovery		%Rec		RPD	QC Limits	
		LCS	LCSD	LCS	LCSD		RPD	%REC
Phenol	50	20.0	19.6	40	39	2	34	15-50
2-Chlorophenol	50	34.5	32.5	69	65	6	46	15-85
1,4-Dichlorobenzene	50	31.0	28.8	62	58	7	46	15-70
Hexachloroethane	50	28.0	26.5	56	53	5	47	15-80
1,2,4-Trichlorobenzene	50	32.7	30.6	65	61	7	52	20-100
4-Chloro-3-methylphenol	50	36.0	36.5	72	73	2	39	30-100
Acenaphthene	50	40.7	38.7	81	77	5	41	30-100
4-Nitrophenol	50	21.6	24.8	43	50	14	62	15-100
2,4-Dinitrotoluene	50	41.5	42.9	83	86	3	33	45-100
Pentachlorophenol	50	32.9	33.6	66	67	2	39	11-110
Pyrene	50	40.1	39.9	80	80	0	33	50-110

\* Outside Control Limits

Method Blank = All Non-Detect

%Rec. = Percent Recovery from LCS & LCSD

RPD=Relative Percent Difference of LCS and LCSD Recoveries



ASSOCIATED LABORATORIES  
806 North Batavia - Orange, California 92868  
714/771-6900 FAX 714/538-1209

CHAIN OF CUSTODY RECORD

Date 8/5/10 Page 1 of 2  
Assigned LR# 259142

CLIENT: AMERICAN GEOTECHNICAL  
ADDRESS: 22725 OLD CANAL ROAD  
YORBA LINDA CA 92687

Is this the address the final report is to be sent to? Yes  No   
If "No" list mailing address in "Special Instructions" section at the bottom of this Chain of Custody.

CONTACT PERSON: CATHERINE GLICK Client  Assoc. Lab Personnel   
SAMPLED BY (Circle One): CATHERINE GLICK

PROJECT IDENTIFICATION/LOCATION: PETER WEBER EQUESTRIAN CENTER  
PURCHASE ORDER #: 5392-01  
SAMPLER: (Print AND Sign) CATHERINE GLICK  
PHONE #: (714) 685 3900  
FAX #: (714) 685 3909  
GLICK CO. ANALYT. LAB

SAMPLE TURNAROUND TIME:  
Requested Turnaround Time (CIRCLE ONE)\*  
Priority Charges Apply to Rush Turn Around Times  
RUSH: Same Day 24 Hr 48 Hr 72 Hr  
STANDARD: Standard TAT \*\* (5 to 10 Working Days)  
Other: Availability of Same Day/24/48/72 Hr TAT Varies Based Upon Test Method Requirements.  
\*\*Standard TAT Varies According to Analyses.

SAMPLE CONDITION INFO - FOR LAB USE ONLY:  
Samples Intact: Yes  No   
Sample Seals Intact: Yes  No   
Cooler Seals Intact: Yes  No

SAMPLE ID	SAMPLE OR LOCATION DESCRIPTION	DATE	TIME	MATRIX (See Codes Below)	# OF CONTAINERS	TEST REQUIRED
1	DRUM #1	8/3/10	9 25	SOIL	1 802 JAM	TPH GAS/BTEX / DIESEL
2	DRUM #2		10 45			TOTAL 22 METALS
3	DRUM #3		13 10			VOC'S B260
4	DRUM #4		15 40			SVOC B270
5	DRUM #5		14 40			B281 <u>STRENGTHENING</u>
6	DRUM #1		9 25		1 402 JAM	
7	DRUM #2		10 45			
8	DRUM #3		13 10			
9	DRUM #4		15 40			
10	DRUM #5		14 40			

MATRIX: GW=Ground Water DW=Drinking Water WW=Waste Water SW=Storm Water S=Solid/Soil A=Air L=Liquid F=Food (Use the codes shown here to identify the matrix above)

Relinquished by: (Print AND Sign) [Signature] Date/Time: 8/5/10  
Relinquished by: (Print AND Sign) [Signature] Date/Time: 8/5/10  
Relinquished by: (Print AND Sign) [Signature] Date/Time: 8/5/10

Special Instructions: 12.153

COC DISTRIBUTION: Yellow to AL. Pink to Client's Courier.



ASSOCIATED LABORATORIES  
806 North Batavia - Orange, California 92868  
714/771-6900 FAX 714/538-1209

Date 8/5/10 Page 2 of 2  
Assigned LR# 259142

**CHAIN OF CUSTODY RECORD**

CLIENT: AMERICAN GEOTECHNICAL  
ADDRESS: 22725 OLD CANYON ROAD  
YORBA LINDA CA 92887

Is this the address the final report is to be sent to? Yes  No   
If "No" list mailing address in "Special Instructions" section at the bottom of this Chain of Custody.

CONTACT PERSON: CATHERINE GLICK  
SAMPLED BY (Circle One): Client Assoc. Lab Personnel

PROJECT IDENTIFICATION/LOCATION:  
PETER WASHA ZUERSTAMEN CENTER  
PURCHASE ORDER #: 5382-01  
SAMPLER: (Print AND Sign) CATHERINE GLICK  
(Signature)  
PHONE#: (714) 685-3900  
FAX #: (714) 685-3707

SAMPLE TURNAROUND TIME:  
Requested Turnaround Time (CIRCLE ONE)\*  
Priority Charges Apply to Rush Turn Around Times  
RUSH: Same Day 24 Hr 48 Hr 72 Hr  
STANDARD: Standard TAT \*\*(\$ to 10 Working Days)  
Other:  
\* Availability of Same Day/24/48/72 Hr TAT Varies Based Upon Test Method Requirements.  
\*\* Standard TAT Varies According to Analyses.

SAMPLE CONDITION INFO - FOR LAB USE ONLY:  
Samples Intact: Yes  No   
Sample Seals Intact: Yes  No  N/A   
Cooler Seals Intact: Yes  No  N/A

SAMPLE ID	SAMPLE OR LOCATION DESCRIPTION	DATE	TIME	MATRIX (See Codes Below)	# OF CONTAINERS	TEST REQUIRED
1	WS 1 A, B, C	8/4/10	1415	WW	3 AMPHISO VCA	TPHS AS/ BTX / DIESEL
2	WS 2	↓	↓	↓	1 PLASTIC	TITLE 22 METALS VOL'S 8260
3	WS 3 A, B, C	↓	↓	↓	3 16oz AMEN	SVOL 8270
4						8281 ORGANOCATIONS P 2572-05
5						
6						
7						
8						
9						
10						

MATRIX: GW=Ground Water / DW=Drinking Water WW=Waste Water SW=Storm Water S=Solid/Soil A=Air L=Liquid F=Food (Use the codes shown here to identify the matrix above)

Relinquished by: (Print AND Sign) 12.33 (Signature) Date/Time: 8-5-10  
Received By: (Print AND Sign) M. E. ... Date/Time:  
Relinquished by: (Print AND Sign) 12.33 (Signature) Date/Time: 8-5-10  
Received By: (Print AND Sign) \_\_\_\_\_ Date/Time:  
Relinquished by: (Print AND Sign) 12.33 (Signature) Date/Time: 8-5-10  
Received By: (Print AND Sign) \_\_\_\_\_ Date/Time:

Special Instructions: 12.33  
COC DISTRIBUTION: White with report. Yellow to AL. Pink to Client's Courier.

\*\*\*By signing this Chain of Custody you are authorizing the analyses shown above. (Print AND Sign)



ASSOCIATED LABORATORIES

806 North Batavia - Orange, California 92868 - 714-771-6900

FAX 714-538-1209

SAMPLE ACCEPTANCE CHECKLIST

**Section 1**  
 Client: American Geo-Tech Project: Peter Weber Equest.  
 Date Received: 8-5-10 Sampler's Name: Yes No  
 Sample(s) received in cooler: Yes No (Skip Section 2)  
 Shipping Information:

**Section 2**  
 Was the cooler packed with:  Ice  Ice Packs  Bubble Wrap  Styrofoam  
 Paper  None  Other \_\_\_\_\_  
 Cooler or box temperature: 5.0 C  
 (Acceptance range is 2 to 6 Deg. C.)

Section 3	YES	NO	N/A
Was a COC received?	<input checked="" type="checkbox"/>		
Is it properly completed? (IDs, sampling date and time, signature, test)	<input checked="" type="checkbox"/>		
Were custody seals present?			<input checked="" type="checkbox"/>
If <del>Yes</del> were they intact?			<input checked="" type="checkbox"/>
Were all samples sealed in plastic bags?	<input checked="" type="checkbox"/>		
Did all samples arrive intact? If no, indicate below.	<input checked="" type="checkbox"/>		
Did all bottle labels agree with COC? (ID, dates and times)	<input checked="" type="checkbox"/>		
Were correct containers used for the tests required?	<input checked="" type="checkbox"/>		
Was a sufficient amount of sample sent for tests indicated?	<input checked="" type="checkbox"/>		
Was there headspace in VOA vials?		<input checked="" type="checkbox"/>	
Were the containers labeled with correct preservatives?	<input checked="" type="checkbox"/>		
Was total residual chlorine measured (Fish Bioassay samples only)? *			<input checked="" type="checkbox"/>

\*: If the answer is no, please inform Fish Bioassay Dept. immediately.

**Section 4**  
 Explanations/Comments

**Section 5**  
 Was Project Manager notified of discrepancies: Y / N N/A

Completed By: M. Ebert Date: 8-5-10

File No. 5382-01  
October 6, 2010

**APPENDIX D**

**Summary of Laboratory Testing**

Exca. No.	Depth (feet)	In-Situ		Optimum Moisture Content (%)	Relative* Compaction (%)	Degree of** Saturation (%)	Expansion Index	Swell (+)/ Collapse (-) (%)	Soil Chemical Testing			
		Dry Density (Lbs/cu. ft.)	Moisture Content (%)						Dry Density (Lbs/cu. ft.)	Chloride (mg/kg)	pH (-)	Resistivity (Ohm-cm)
AGSB-1	2.5-4.0	56.0	19.6	-	-	26	-	-	-	-	-	-
AGSB-1	5.0-6.5	58.3	23.0	-	-	33	-	-	-	-	-	-
AGSB-1	10-11.5	51.1	21.6	-	-	25	-	-	-	-	-	-
AGSB-2	0.0-5.0	-	-	105	17	-	-	-	-	222	7.66	324
AGSB-2	5.0-6.5	36.8	90.4	-	35	68	-	+0.18@420 psf	-	-	-	2560
AGSB-2	15-16.5	64.7	50.2	-	-	84	-	-	-	-	-	-
AGSB-3	2.0-5.0	-	-	-	-	-	57	-	-	164	7.93	988
AGSB-3	2.5-4.0	73.1	40.2	-	37	83	-	+0.20@330 psf	-	-	-	-
AGSB-3	5.0-6.5	60.3	76.1	-	-	115	-	+0.68@635 psf	-	-	-	-
AGSB-3	10-11.5	58.6	57.6	-	-	83	-	-	-	-	-	-
AGSB-3	15-16.5	72.9	48.2	-	-	99	-	-	-	-	-	-
AGSB-4	2.5-4.0	74.9	32.1	-	68	69	-	+0.67@375 psf	-	-	-	-
AGSB-4	3.0-5.0	-	-	110	15.5	-	-	-	-	-	-	-
AGSB-4	5.0-6.5	65.7	41.5	-	-	72	-	+0.45@560 psf	-	-	-	-
AGSB-4	10-11.5	75.0	32.4	-	-	70	-	-	-	-	-	-
AGSB-4	15-16.5	69.3	46.7	-	-	88	-	-	-	-	-	-
AGSB-4	19-20	49.5	60.6	-	-	68	-	-	-	-	-	-
AGSB-5	0.0-5.0	-	-	115.5	13	-	-	-	-	-	-	-
AGSB-5	2.0-5.0	-	-	-	-	-	74	-	-	-	-	-
AGSB-5	2.5-4.0	75.2	42.8	-	-	93	-	+0.95@350 psf	-	-	-	-
AGSB-5	5.0-6.5	69.9	47.9	-	-	92	-	+0.21@625 psf	-	-	-	-
AGSB-5	10-11.5	75.4	38.1	-	-	83	-	+0.40@1150 psf	-	-	-	-
AGSB-5	15-16.5	56.2	49.6	-	-	67	-	-	-	-	-	-
AGSB-5	19-20	73.7	47.4	-	-	99	-	-	-	-	-	-

Note: \* Relative compaction was calculated using the maximum dry density at the nearest location or average of 109 pcf  
Note: \* Degree of saturation was calculated using specific gravity of 2.70



Exca. No.	Depth (feet)	In-Situ		Optimum Moisture Content (%)	Maximum Dry Density (Lbs/cu. ft.)	Relative Compaction (%)	Degree of Saturation (%)	Expansion Index	Swell (+)/ Collapse (-) (%)	Soil Chemical Testing			
		Dry Density (Lbs/cu. ft.)	Moisture Content (%)							Chloride (mg/kg)	pH (-)	Resistivity (Ohm-cm)	Sulfate (mg/kg)
AGSB-6	0.0-2.0	-	-	-	-	-	-	69	-	196	7.87	655	626
AGSB-6	2.5-4.0	69.1	42.8	-	-	66	80	-	+0.46@320 psf	-	-	-	-
AGSB-6	5.0-7.0	-	-	17.0	105.5	-	-	-	-	-	-	-	-
AGSB-6	5.0-6.5	86.4	27.1	-	-	82	77	-	+0.17@660 psf	-	-	-	-
AGSB-6	10-11.5	78.0	37.0	-	-	-	86	-	+1.09@1175 psf	-	-	-	-
AGSB-6	19-20	55.8	54.1	-	-	-	72	-	-	-	-	-	-

Note: \* Relative compaction was calculated using the maximum dry density at the nearest location or average of 109 pcf  
Note: \* Degree of saturation was calculated using specific gravity of 2.70

SUMMARY OF LABORATORY TESTING DATA

AMERICAN GEOTECHNICAL

PETER WEBER

F.N. 5382.01

OCT. 2010

TABLE

D2

Exca. No.	Depth (ft)	Soil Classification USCS	% Soil				Clay (%)	Passing No. 200 (%)	Atterberg Limits		
			Sand (%)	Silt (%)	LL (%)	PL (%)			PI (%)		
AGSB-2	5.0-10.0	MH	11	51	38	89	82	48	34		
ABSB-4	3.0-5.0	CH	32	36	32	68	58	30	28		
AGSB-5	2.0-5.0	CH	39	35	26	61	55	28	27		
AGSB-6	0.0-2.0	CH	36	36	28	64	56	30	26		

SUMMARY OF LABORATORY TEST DATA

TABLE

AMERICAN GEOTECHNICAL

PETER WEBER

F.N. 5382.01

OCT. 2010

D3

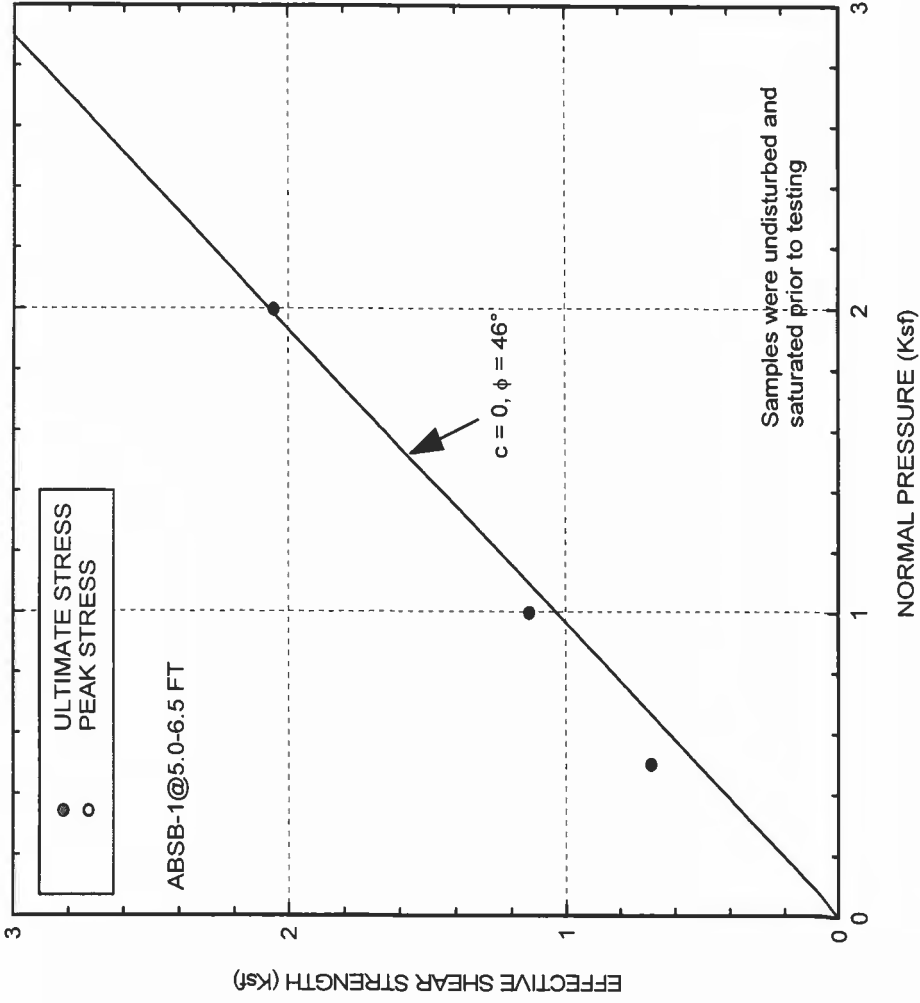

DIRECT SHEAR TEST PLOT

AMERICAN GEOTECHNICAL

PETER WEBER

F.N. 5382.01

OCT. 2010

FIGURE

D1

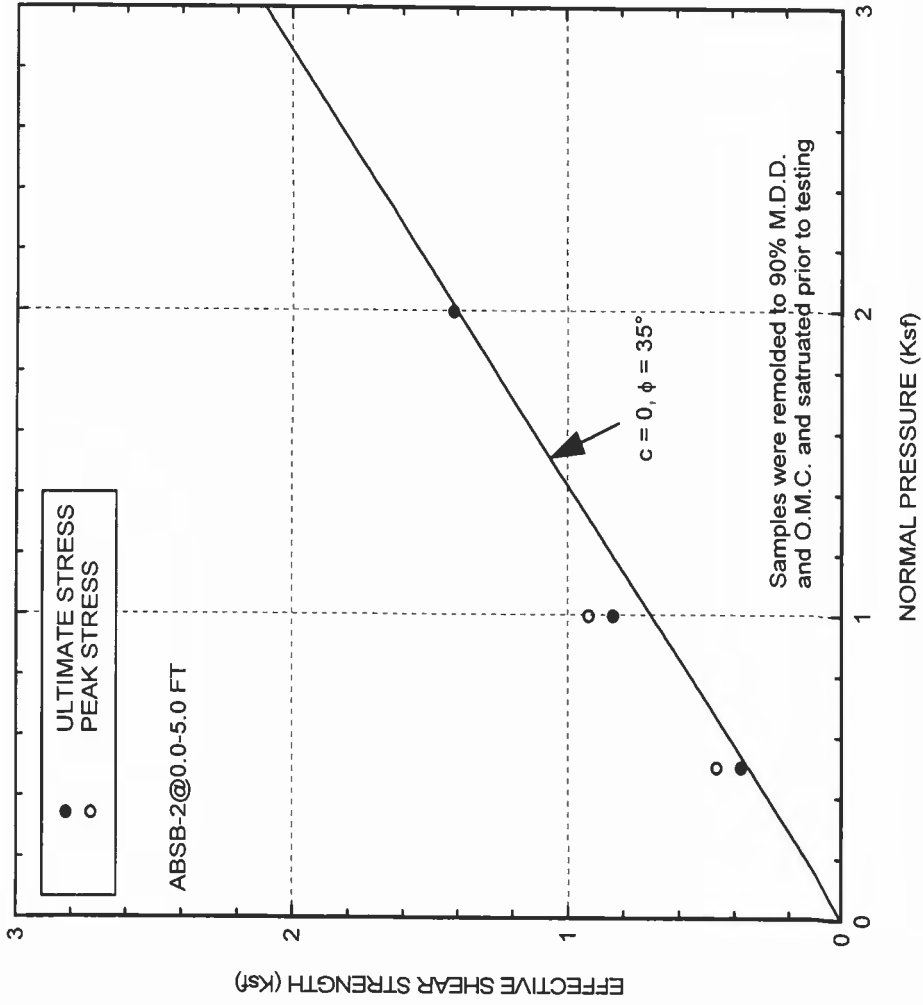

DIRECT SHEAR TEST PLOT

AMERICAN GEOTECHNICAL | PETER WEBER | F.N. 5382.01 | OCT. 2010

FIGURE D2

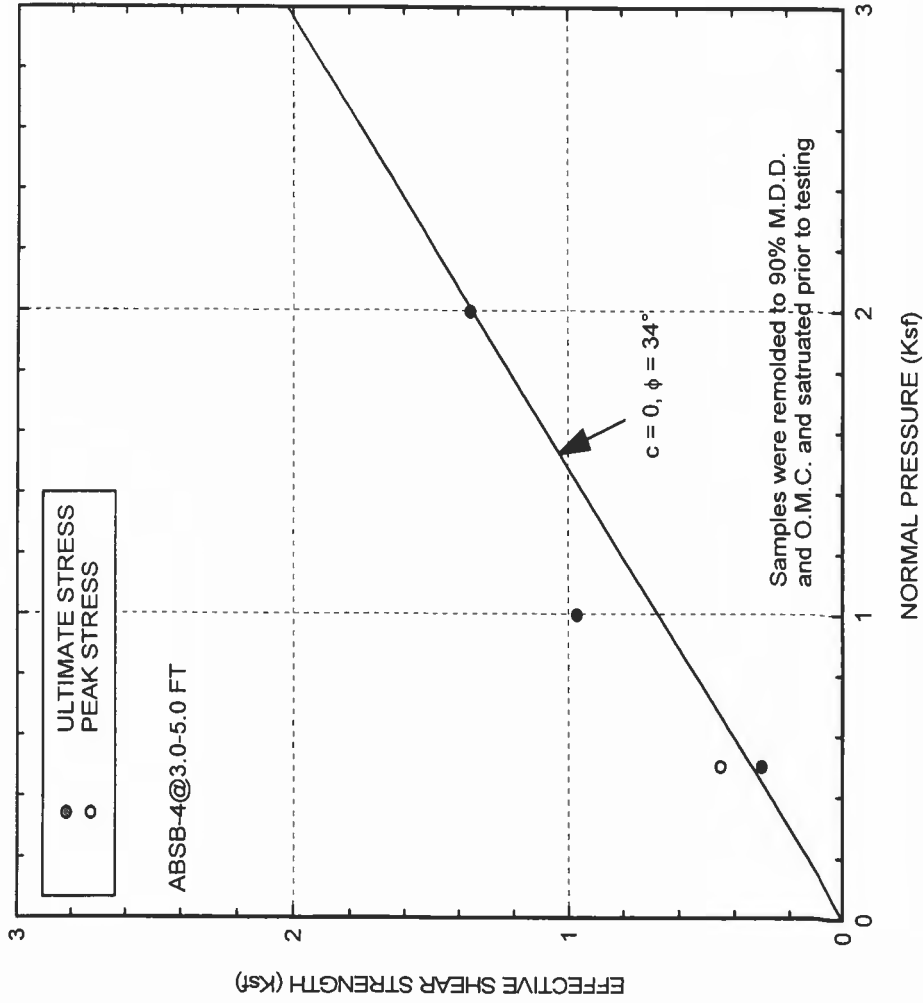

DIRECT SHEAR TEST PLOT

AMERICAN GEOTECHNICAL | PETER WEBER | F.N. 5382.01 | OCT. 2010

FIGURE D3

File No. 5382-01  
October 6, 2010

**APPENDIX E**

**Geotechnical Guidelines for Grading Projects**

**Geotechnical Guidelines for Grading Projects**

**TABLE OF CONTENTS**

1.0	GENERAL .....	2
2.0	OBLIGATIONS OF PARTIES .....	2
3.0	SITE PREPARATION .....	2
3.1	.....	2
3.2	.....	2
3.3	.....	2
4.0	SITE PROTECTION.....	3
4.1	.....	3
4.2	.....	3
4.3	.....	3
4.4	.....	3
5.0	EXCAVATIONS.....	3
5.1	.....	3
5.2	.....	3
6.0	COMPACTED FILL.....	3
6.1	.....	3
6.2	.....	3
6.3	.....	4
6.4	.....	4
6.5	.....	4
6.6	.....	5
6.7	.....	5
7.0	TRENCH BACKFILL.....	5
7.1	.....	5
7.2	.....	5
7.3	.....	5
8.0	STATUS OF GRADING .....	5

## Geotechnical Guidelines for Grading Projects

### GEOTECHNICAL GUIDELINES FOR GRADING PROJECTS

#### 1.0 GENERAL

These guidelines should be considered to be a portion of the project specifications. The contractor should not vary from these guidelines without prior recommendation by the geotechnical consultant and approval of the client or his authorized representative. Recommendations by the geotechnical consultant and/or client should not be considered to preclude requirements for approval by the controlling agency. If disputes arise out of the interpretation of these grading guidelines, the geotechnical consultant shall provide the governing interpretation.

#### 2.0 OBLIGATIONS OF PARTIES

The geotechnical consultant should be authorized by the client to provide observation and testing services during grading. The geotechnical consultant will report his findings and recommendations to the client or his authorized representative. The client should be chiefly responsible for all aspects of the project. The client or his authorized representative has the responsibility of reviewing the findings and recommendations of the geotechnical consultant. During grading, the client or his authorized representative should remain on site or should remain reasonably accessible to all concerned parties in order to make decisions necessary to maintain the flow of the project.

#### 3.0 SITE PREPARATION

- 3.1 Prior to any site preparation or grading, the client should arrange and attend a meeting among the grading contractor, the design engineer, the geotechnical consultant, and representatives of the appropriate governing authorities as well as any other concerned parties. All parties should be given at least 48 hours notice.
- 3.2 Clearing and grubbing should consist of the removal of vegetation and otherwise deleterious natural materials from the areas to be graded. Clearing and grubbing should extend to the outside of all proposed excavation and fill areas.
- 3.3 Demolition should include removal of buildings, structures, foundations, reservoirs, utilities (including underground pipelines, septic tanks, leach fields, seepage pits, cisterns, mining shafts, tunnels, etc.), and other man-made surface and subsurface improvements from the areas to be graded. Demolition of utilities should include proper capping and/or rerouting of pipelines at the project perimeter and cutoff and capping of wells in accordance with the requirements of the governing authorities. Trees, plants, or man-made improvements not planned to be removed or demolished should be protected by the contractor. Debris generated during clearing, grubbing, and/or demolition operations should be removed from areas to be graded and disposed of off-site.



## Geotechnical Guidelines for Grading Projects

### 4.0 SITE PROTECTION

- 4.1 Protection of the site during the period of demolition and grading should be the responsibility of the contractor. The contractor should be responsible for the stability of all temporary excavations including buttress and retaining wall cuts.
- 4.2 The contractor should control dust at all times.
- 4.3 Precautions should be taken during the performance of site clearing, excavating, and grading to protect the work site from flooding, ponding, erosion, and all other damage by poor or improper surface drainage.
- 4.4 During periods of rainfall, the geotechnical consultant should be kept informed by the contractor as to the nature of remedial or preventative work being performed. Following periods of rainfall, the contractor should contact the geotechnical consultant and arrange a visual inspection of the site in order to assess rain-related damage. Adversely affected soil will be classified as unsuitable material and should be subject to overexcavation and replacement with compacted fill or other remedial grading.

### 5.0 EXCAVATIONS

- 5.1 Material which is unsuitable should be excavated under the observation and recommendations of the geotechnical consultant. Unsuitable material includes, but may not be limited to, dry, loose, soft, wet, organic, compressible, natural soil, and fractured, weathered, soft bedrock and non-engineered or otherwise deleterious fill material.
- 5.2 Unless otherwise recommended by the geotechnical consultant and approved by regulating agencies, permanent cut slopes should not be steeper than 2:1 (horizontal to vertical).

### 6.0 COMPACTED FILL

- 6.1 Prior to placement of compacted fill, the contractor should request a review by the geotechnical consultant of the exposed ground surface. Unless otherwise recommended, the exposed ground surface should be scarified (six inches minimum), watered or dried as needed, thoroughly blended to achieve near optimum moisture conditions, then thoroughly compacted to a minimum of 90 percent of the maximum density.
- 6.2 Compacted fill should then be placed in thin horizontal lifts not exceeding eight inches in loose thickness prior to compaction. Each lift should be watered or dried as needed, thoroughly blended to achieve near optimum moisture conditions, then thoroughly compacted by mechanical methods. Depending on the type of soil and compaction equipment, thinner lifts could be recommended. Each lift should be treated in a like manner until the desired finished grades are achieved. The contractor should have suitable and sufficient mechanical compaction equipment, watering apparatus and mixing

## Geotechnical Guidelines for Grading Projects

capability on the job site to handle the amount of fill being placed. If necessary, excavation equipment should be "shut down" temporarily in order to permit proper compaction of fills. Earth moving equipment should only be considered a supplement and not substituted for conventional compaction equipment.

- 6.3 Unless otherwise specified, the minimum degree of compaction required is 90 percent of the laboratory maximum density. Depending on the soil type, depth of fill and/or other conditions, higher relative compaction could be recommended. Maximum density should be determined in accordance with ASTM Method of Test D1557, Method A or C.
- 6.4 Fill should be tested for compliance with the recommended relative compaction and moisture conditions. Field density testing should conform to ASTM Method of Test D1556, D2922 and/or D2937. Tests should be taken for about every two vertical feet or 1,000 cubic yards of fill placed. Where gravel is encountered, dry density should be corrected by the subtraction/elimination method. Actual test intervals may vary as field conditions dictate. Fill not found to be in conformance with the grading recommendations should be removed or otherwise handled as recommended by the geotechnical consultant. The contractor should assist the geotechnical consultant in digging test pits for testing compacted fill. As recommended by the geotechnical consultant, the contractor should "shut down" or remove grading equipment from an area being tested.

Maximum density testing may be required of samples obtained directly from the fill areas in order to verify conformance with the specifications. Processing of these additional samples may take two or more working days. The contractor may elect to move the operation to other areas within the project, or may continue placing compacted fill pending laboratory and field test results. Should he elect the second alternative, fill placed is done so at the contractor's risk.

- 6.5 For field testing purposes, near optimum moisture will vary with material type and other factors including compaction procedure. Near optimum moisture may be specifically recommended in Preliminary Investigation Reports and/or may be evaluated during grading. As a preliminary guideline, near optimum moisture should be considered from one percent below to three percent above optimum.

Prior to placement of additional compacted fill following an overnight or other grading delay, the exposed surface or previously compacted fill should be processed by scarification, watered, or dried as needed, thoroughly blended to near optimum moisture conditions, then recompacted. Where wet, dry, or other unsuitable material exists to depths of greater than eight inches, the unsuitable material should be overexcavated.

Excavated on-site material which is acceptable to the geotechnical consultant may be utilized as compacted fill. Where import materials are required for use on site, the geotechnical consultant should be notified at least 72 hours in advance of importing in order to sample and test materials from proposed borrow sites.

## Geotechnical Guidelines for Grading Projects

- 6.6 Rocks up to a maximum diameter of 12 inches may be utilized within the compacted fill provided they are placed in such a manner that nesting of the rock is avoided and compaction is achieved. Rocks greater than six inches in maximum diameter should not be placed in the upper four feet of compacted fill. Fill should be placed and thoroughly compacted over and around all rock. The amount of rock should not exceed 40 percent by dry weight passing the 3/4-inch sieve size.

During the course of grading operations, rocks or similar irreducible materials greater than 12 inches maximum diameter (oversized material) may be generated. These rocks should not be placed within the compacted fill unless accepted and placed in conformance with the geotechnical consultant's recommendations.

- 6.7 Unless otherwise recommended by the geotechnical consultant and approved by the regulating agencies, permanent fill slopes should not be steeper than 2:1 (horizontal to vertical).

### 7.0 TRENCH BACKFILL

- 7.1 Utility trench backfill should, unless otherwise recommended, be compacted by mechanical means. The degree of compaction should be a minimum of 90 percent of the laboratory maximum density unless otherwise recommended. As an alternative, where agreed to in advance by the geotechnical consultant, granular material (sand equivalent greater than 30) may be thoroughly jetted in place. Jetting should only be considered to apply to trenches no greater than two feet in width and four feet in depth. Following jetting operations, trench backfill should be thoroughly mechanically compacted and/or wheel-rolled from the surface.
- 7.2 Backfill of exterior and interior trenches extending below a 1:1 projection from the outer edge of foundations should be mechanically compacted.
- 7.3 Clean granular backfill and/or bedding are not recommended in slope areas unless provisions are made for a drainage system to mitigate the potential buildup of seepage forces.

### 8.0 STATUS OF GRADING

Prior to proceeding with any grading operation, the geotechnical consultant should be notified at least two working days in advance in order to schedule the necessary observation and testing services. Prior to any significant expansion or cutback in the grading operation, the geotechnical consultant should be provided with adequate notice (i.e., two days) in order to make appropriate adjustments in observation and testing services. Following completion of grading operations, and/or between phases of a grading operation, the geotechnical consultant should be provided with at least two working days notice in advance of commencement of additional grading operations.



CITY OF RANCHO PALOS VERDES  
OFFICE OF THE CITY MANAGER

October 15, 2008

Shelley Luce, Ph.D., Executive Director  
Santa Monica Bay Restoration Commission  
320 West 4<sup>th</sup> Street, Suite 200  
Los Angeles, CA 90013

Subject: Model Equestrian Center grant proposal by the City of Rolling Hills Estates

Dear Dr. Luce,

The City of Rolling Hills Estates Peter Weber Equestrian Center is a South Bay regional recreational resource heavily utilized by the public. The City of Rancho Palos Verdes is supportive of the planned renovation and expansion of the facility.

This facility is optimally suited for the creation of a Model Equestrian Center to demonstrate the latest ideas in environmentally sustainable horse keeping practices. We know of no such demonstration site currently in existence within the South Bay area. Those of us in the equestrian community pride ourselves on being good stewards of the environment and we are among the greatest advocates in the community in support of open space and public trails. The benefits of this project are numerous and it will be met with strong support among the equestrian community at large.

The City of Rancho Palos Verdes would very much appreciate the funding of this project by the Santa Monica Bay Restoration Commission.

Sincerely,

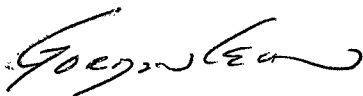

Gordon Leon  
Chair, Equestrian Committee





CITY OF  
*Palos Verdes Estates*

OFFICE OF  
THE CITY MANAGER

October 15, 2008

Shelley Luce, Ph.D., Executive Director  
Santa Monica Bay Restoration Commission  
320 West 4<sup>th</sup> Street, Suite 200  
Los Angeles, CA 90013

Subject: Model Equestrian Center Grant Proposal by the City of Rolling Hills Estates

Dear Dr. Luce:

It is my pleasure to provide you with this letter of support for the above referenced project in our neighboring city of Rolling Hills Estates. As you may be aware, the City of Rolling Hills Estates owns and operates the Peter Weber Equestrian Center – a boarding facility for private horses serving the South Bay area. Rolling Hills Estates is planning to renovate their facility and the City of Palos Verdes Estates is supportive of this project.

The Rolling Hills Estates facility is optimally suited for the creation of a Model Equestrian Center to be used to demonstrate the latest ideas in environmentally sustainable horse keeping practices; no such demonstration site currently exists in the South Bay area. The equestrian community prides itself on being good stewards of the environment and we are among the greatest advocates in the community in support of open space and public trails. The benefits of this project are numerous and will be met with strong support among the equestrian community.

The City of Palos Verdes Estates would very much welcome the funding of this project by the Santa Monica Bay Restoration Commission. Should you desire additional information, please don't hesitate to contact me at your convenience.

Sincerely,

Joseph Hoefgen  
City Manager

cc: Mr. Doug Prichard, City Manager, Rolling Hills Estates



Palos  
Verdes  
Peninsula  
Horsemen's  
Association

October 14, 2008

Shelley Luce, Ph.D., Executive Director  
Santa Monica Bay Restoration Commission  
320 West 4<sup>th</sup> Street, Suite 200  
Los Angeles, CA 90013

Subject: Model Equestrian Center grant proposal by the City of Rolling Hills Estates.

Dear Dr. Luce,

The city of Rolling Hills Estates Peter Weber Equestrian Center is a South Bay regional resource which is very heavily utilized by the public, drawing equestrians from many cities though out the South Bay. The Palos Verdes Horsemen's Association (PVPHA) is dedicated to *preserving horse keeping on the Palos Verdes Peninsula* and is strongly supportive of the planned renovation and expansion of the facility.

This facility is ideally suited for the recreation of a Model Equestrian Center to demonstrate the latest technology in environmentally sustainable horse keeping practices; there is not any such demonstration site currently in the South Bay area. The PVPHA takes pride in being good equestrian stewards of the environment and we are great advocates in the community supporting open space and protecting and promoting public trails and equestrian facilities. Many of our members are also boarders at the Peter Weber Equestrian Facility. We feel that the there are many great benefits of this project and it will be met with strong support of the equestrian community.

The PVPHA strongly supports the funding of this project by the Santa Monica Bay Restoration Commission.

Sincerely,

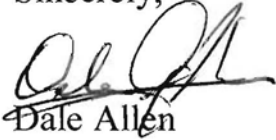
A handwritten signature in black ink, appearing to read "Dale Allen". The signature is written in a cursive style with a prominent loop at the end.

Dale Allen

President

Palos Verdes Peninsula Horsemen's Association



Cathy Gardner, DC  
3 Santa Bella Road  
Rolling Hills Estates CA 90274  
(310) 541.3452



October 9, 2008

Shelley Luce, Ph.D., Executive Director  
Santa Monica Bay Resotoration Commission  
320 West 4<sup>th</sup> Street, Sute 200  
Los Angeles, CA 90013

Re: Model Equestrian Center Grant Proposal by the City of RHE

Dear Dr. Luce,

Palos Verdes Pony Club is a local children's non-profit equestrian group of the United States Pony Clubs located in Rolling Hills Estates, California. We utilize the equestrian trails, rings and stables here in our City.

We support and ask that you support funding of The City of Rolling Hills Estates Peter Weber Equestrian Center upgrades to the planned Model Equestrian Center. This public facility would support many wholesome children and adult activities that are becoming all but extinct here in the County of Los Angeles south bay area.

Thank you for your positive actions on behalf of this valuable project that will be met with gratitude for generations to come.

Sincerely,

PALOS VERDES PONY CLUB

Cathy Gardner  
Founder





Department of  
Toxic Substances  
Control

*The mission of  
the Department  
of Toxic  
Substances  
Control is to  
provide the  
highest level of  
safety, and to  
protect public  
health and the  
environment  
from toxic  
harm.*



State of California



California  
Environmental  
Protection Agency

Fact Sheet #13, November 2009

## Five-Year Review Completed

### Palos Verdes Landfill is Safe and Well-Maintained

#### ANNOUNCEMENT

The Department of Toxic Substance Control (DTSC) announces the conclusion of the public comment period and completion of the Five-Year Review for the Palos Verdes Landfill. Findings of the Five-Year Review indicate that the environmental control systems currently in place at the Palos Verdes Landfill continue to be effective in protecting human health and the environment. The Five-Year Review concludes with recommendations for continued operation, maintenance, and monitoring of the environmental control systems implemented for groundwater, landfill gas, and soil cover. These environmental control systems will be subject to another review in five years.



Palos Verdes Landfill – View to the West

#### INTRODUCTION

This is the fifth fact sheet provided during the Five-Year Review. This fact sheet describes the purpose of the Five-Year Review, summarizes DTSC's community outreach efforts during the public comments period, and announces the completion and release of the final Five-Year Review document.

#### PURPOSE OF THE FIVE-YEAR REVIEW

As documented in the 1995 Remedial Investigation Report for the Palos Verdes Landfill, groundwater contamination was first discovered at the Site in the early 1980s. As a result, a comprehensive Remedial Investigation and an associated Feasibility Study were conducted between 1988 and 1995 to characterize the nature and extent of contamination at and from the Site, to evaluate potential health risks, and to determine appropriate remedial measures. A Remedial Action Plan was prepared based on findings of the Remedial Investigation and the subsequent Feasibility Study.

To verify that remedial measures implemented at the Palos Verdes Landfill continue to meet all remedial action objectives, DTSC reviews facility performance every five years. The first of these five-year reviews started in 2004. Major elements evaluated during the Five-Year Review include:

- *Groundwater Protection Systems*
- *Gas Collection and Control System (Surface Air and Subsurface Gas)*
- *Soil Cover*
- *Stormwater*
- *Wastewater*
- *An Updated Health Risk Assessment*

These elements were evaluated and technically assessed for protectiveness during the Five-Year Review to answer three key questions:

- Is the remedy functioning as intended by the decision documents?
- Are the remedial action objectives used at the time of remedy selection still valid?
- Has any other information come to light that could call into question the protectiveness of the remedy?

As the first five-year review performed for the Palos Verdes Landfill, the scope of this review was modified and expanded to include multiple special studies in response to requests and concerns from the community. The final Five-Year Review document as a result, has become an extensively comprehensive reference not only for typical elements required for evaluation in a five-year review, but also a compilation of evaluations, findings, and discussions that thoroughly addressed concerns expressed by members of the community.

## **PUBLIC COMMENT PERIOD**

On March 5, 2009, DTSC announced the completion of the Five-Year Review and the commencement of a 60-day public comment period on March 9, 2009. DTSC distributed Fact Sheet #12 to 3,700 residents to inform the community about the completion of the Five-Year Review and to provide information on the public comment process. An electronic version of the Five-Year Review document was made available on DTSC's website and EnviroStor shortly before the public comment period started:

[http://www.envirostor.dtsc.ca.gov/public/profile\\_report.asp?global\\_id=19490181](http://www.envirostor.dtsc.ca.gov/public/profile_report.asp?global_id=19490181)

Paper copies of the Five-Year Review document were delivered to two local libraries, Peninsula Center Library and Torrance Civic Center Library, for public reference during the comment period.

At the invitation of the City of Rolling Hills Estates, DTSC provided a presentation and reported findings of the Five-Year Review to elected officials and community members on March 10, 2009 at the Rolling Hills Estates City Council Meeting. During the meeting, DTSC granted a 30-day extension of the public comment period at the request of the Citizens Advisory Board. A subsequent 30-day extension was granted at another request from the Citizens Advisory Board, revising the end of the public comment period to July 8, 2009.

An open house and public comment meeting was held on April 27, 2009 at the South Coast Botanic Garden. The purpose of the meeting was to provide opportunity for the public to become more informed of the findings from the Five-Year Review, engage in dialogue and ask questions of DTSC's technical staff to address outstanding concerns or comments about the Palos Verdes Landfill. During the open house and public comment sessions of the meeting, DTSC received and responded to questions from the community. DTSC responded to the questions posed during the meeting and questions submitted during the public comment period. Responses to comments are documented in Appendix K of the Five-Year Review and are available at DTSC's EnviroStor website.

## **COMPLETION OF THE FIVE-YEAR REVIEW**

The technical assessment of the environmental control systems and conclusions of the associated special studies performed during the Five-Year Review indicate that the Palos Verdes Landfill is safe, well maintained, and protective of human health and the environment. After considering all public comments received, DTSC concludes:

- The remedial systems are functioning as intended by the decision documents with respect to all media (groundwater, surface air and subsurface gas, soil cover, stormwater, and wastewater);
- The remedial action objectives used at the time of remedy selection are still valid;
- No other information has come to light that calls into question the protectiveness of the remedy.

Therefore, DTSC approves the Five-Year Review document, dated March 2009, in its entirety with the inclusion of Appendix K, Public Comment Period Responsiveness Summary.

### **WHERE TO FIND THE FIVE-YEAR REVIEW**

The final Five-Year Review document is available on DTSC's website at:

[http://www.envirostor.dtsc.ca.gov/public/profile\\_report.asp?global\\_id=19490181](http://www.envirostor.dtsc.ca.gov/public/profile_report.asp?global_id=19490181)

To review information at DTSC, please call Julie Johnson, File Room Coordinator, at (714) 484-5337, or ext 5336, or fax (714) 484-5318 for an appointment.

### **AGENCY CONTACTS**

DTSC encourages the public to contact the individuals below to address any questions or concerns regarding the Palos Verdes Landfill.

#### **Department of Toxic Substances Control**

Daniel Zogaib, Project Manager  
Phone: (714) 484-5483  
[dzogaib@dtsc.ca.gov](mailto:dzogaib@dtsc.ca.gov)

Tim Chauvel, Public Participation Specialist  
Phone: (714) 484-5487  
[tchauvel@dtsc.ca.gov](mailto:tchauvel@dtsc.ca.gov)

#### **Sanitation Districts of Los Angeles County**

David Rothbart, Project Engineer  
Phone: (562) 908-4288, extension 2412  
[drothbart@lacsdc.org](mailto:drothbart@lacsdc.org)

This is the fifth and final fact sheet provided by DTSC on this Five-Year Review. To review past fact sheet information, please visit DTSC's EnviroStor.

## **Sub-Appendix I-A**

---

Palos Verdes Landfill 5-Year Review Community Survey Results,  
DTSC, November 2004  
DTSC, December 2005



***PALOS VERDES LANDFILL  
5-YEAR REVIEW COMMUNITY SURVEY  
RESULTS  
November 2004***

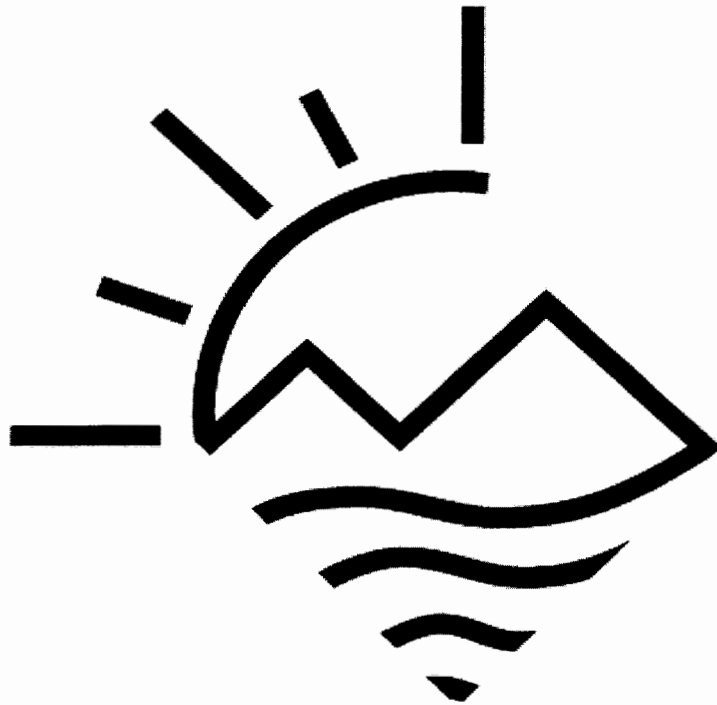

**DEPARTMENT OF TOXIC  
SUBSTANCES CONTROL**

Compiled by:

Tim Chauvel  
Public Participation Specialist  
Department of Toxic Substances  
Control  
5796 Corporate Avenue  
Cypress, CA 90630  
Phone: (714) 484-5487  
Fax: (714) 484-5329  
E-mail: [tchauvel@dtsc.ca.gov](mailto:tchauvel@dtsc.ca.gov)



**TABLE OF CONTENTS**

	<b>Page</b>
<b>1.0 INTRODUCTION .....</b>	<b>4</b>
<b>TABLE 1: SUMMARY OF SURVEY RESULTS.....</b>	<b>4</b>
<b>2.0 SURVEY RESULTS .....</b>	<b>5</b>
<b><u>SURVEY QUESTION 1: HOW LONG HAVE YOU LIVED IN THE AREA?.....</u></b>	<b>5</b>
<b><u>SURVEY QUESTION 2: WHAT IS YOUR CURRENT LEVEL OF INTEREST IN THIS LANDFILL?.....</u></b>	<b>5</b>
<b><u>SURVEY QUESTION 3: HAVE YOU NOTICED ANYTHING OUT OF THE ORDINARY REGARDING THE LANDFILL? IF SO, DID YOU REPORT THE INFORMATION? PLEASE EXPLAIN WHO YOU CONTACTED, AND WHY. ....</u></b>	<b>5</b>
<b><u>SURVEY QUESTION 4: DO YOU HAVE ANY OTHER COMMENTS THAT WILL ASSIST DTSC IN UNDERTAKING THE FIVE-YEAR REVIEW OF THE LANDFILL?.....</u></b>	<b>7</b>
<b><u>SURVEY QUESTION 5: DID YOU FIND THE INFORMATION CONTAINED IN THIS FACT SHEET USEFUL? .....</u></b>	<b>9</b>
<b>3.0 GEOGRAPHICAL LOCATION OF SURVEY RESPONSES.....</b>	<b>10</b>

## 1.0 Introduction

The Department of Toxic Substances Control (DTSC) supervised the mailing of a fact sheet and community survey in March 2004 to residents living in close proximity to the Palos Verdes Landfill. The fact sheet informed the community of the start of DTSC's legally mandated five-year review of the effectiveness of existing landfill safety systems that are in place to protect public health and the environment. The survey invited the community to mail back comments and concerns associated with the operation of the landfill. As of November 2004, DTSC has received forty-two responses.

Section two of this report shows each original survey question followed by unabridged public comment. Name and mailing address details have been omitted in order to protect the identity of survey respondents.

**Table 1: Summary of Survey Results**

<b>Survey Results</b>	<b>No. of Responses</b>
Number of Survey Responses Received	42
<b>How long have you lived in the area</b>	
0-5 years	5
6-12 years	4
13-20 years	10
21 or more years	22
<b>Level of public interest</b>	
Moderate to High	34
Low to Moderate	6
None (no response)	1

Note: Table does not show complete list of survey results.



## 2.0 Survey Results

**Number of Survey Responses Received = 42**

**Disclaimer:** The self-selected group of people who responded to this community survey cannot be viewed as statistically representative of the total population of residents living in close proximity to the Palos Verdes landfill.

### Survey Question 1: How long have you lived in the area?

**Public Response:**

Years lived in area	0 – 5 years	6 – 12 years	13 – 20 years	21 or more years
Number of responses	5	4	10	22

### Survey Question 2: What is your current level of interest in this landfill?

**Public Response:**

Level of Interest	None	Low to moderate	Moderate to high
Number of responses	1	6	34

**Survey Question 3: Have you noticed anything out of the ordinary regarding the landfill? If so, did you report the information? Please explain who you contacted, and why.**

**Public response:**

Number of responses to Question 3	No response to Question 3
18	24

**Note:** The following public comments are unabridged direct quotes.

1. *When they dug up and redesigned the current golf course, we on Delos Drive were inundated by field mice. Had to get a company to set traps around and in the house to exterminate. [Torrance]*

## California Department of Toxic Substances Control

---

2. *The odor was really bad when we first moved in, but nothing in several years. [Carolwood Lane, Torrance]*
3. *Water seepage from under the... top at the corner of Carolwood and ...wood [?], especially after it rains.*
4. *The gas well close to Hawthorn Blvd. always emits... smoke in the morning. I did make contact, but don't remember who I contacted. Could the smoke be filtered or controlled? [Torrance]*
5. *Leaking pipes (I hear them). Rain water seeping into cracks in ground. Sink holes on horse trail. Sweet smell that causes salivation. Repeated ground sinking (30 to 70 feet) behind stable and by the trails, it has dropped 10 feet since the area was filled in the 90's. [Ripley Ave.]*
6. *Pops and hissing coming from pipes. Sink holes on all levels of the landfill. Constant movement of land on Crenshaw and surrounding properties. I did contact the workers. [Via Linda Vista]*
7. *I have lived on the northern border of the South Coast Botanic Garden since 1978. I have seen underground fires and that border that seem to be somewhat under control. Crenshaw between the landfill and the Garden continue to have soil subsidence and drainage problems despite many and costly repairs. There was also a very noisy breakdown of the gas collection machinery - I called, and it was rep Number of responses aired. Please address the black ooze problem (on the n.w. corner) and other problems reported in recent articles in the Palos Verdes Peninsula News. [Hidden Lane, Palos Verdes Peninsula]*
8. *We live on Briarwood Dr., the street closest to the landfill. In recent years we have noticed water oozing out from the street long after it has rained... [Torrance]*
9. *Noxious fumes reported to AQMD on 2-3, occasions around 1977-85. Also extreme dust and noise during operation. Periodic oozing of liquids to surface in country hills development - continues to present. [226 th Street, Torrance]*
10. *Landslide downhill from landfill associated with recharge of wells above and below the landslide. [Carolwood Ln., Torrance]*
11. *There is a lot of underground water in the neighborhood which could be coming from the landfill which sits above us. [Singwood Dr. Torrance]*
12. *Several years ago the men on the landfill used to have huge pumpkin/squash patches that got water 24 hours a day. This is directly above where the houses began sliding. [Moccasin Lane, Rolling Hills Estates]*
13. *Methane gas escaping periodically. No available person to call - we had a number 10 years ago. [Oakwood Lane, Torrance]*
14. *No - never noticed any odd or unusual occurrences, visited Botanical Garden and other parts of site often over the years. [Capeswood drive, Rancho Palos Verdes]*
15. *In the evening, often times I can smell the odor from burning. The odor smells very unpleasant and toxic. [Carolwood Ln., Torrance]*

16. *I have smelled "chemical" odors and I called 1-800-cutsmog to report it. [Singingwood Dr., Torrance]*
17. *There are noxious odors in the neighborhood at times (not skunks). There are streams of whitish cloudy water running along the curb into the drain (on Carolwood Ln.) - not reported. [Carolwood Ln., Torrance]*
18. *I haven't seen anything unusual - but I do recall hearing about a runoff or underground migration concerning north of the main site. Damage was caused off Rolling Hills Rd., at the Ralph's (then it might have been Hughes?). Was it ever resolved? [Palos Verdes Peninsula]*

**Survey Question 4: Do you have any other comments that will assist DTSC in undertaking the five-year review of the landfill?**

**Note:** The following public comments are unabridged direct quotes.

**Public response:**

Number of responses to Question 3	No response to Question 3
20	22

1. *Maintain the chain link fence on the boundary between the Palos Verdes Landfill in Rolling Hills estates and the private property in the City of Torrance. [Carolwood Lane, Torrance]*
2. *Appreciate the interest in both the safety and potential uses as to amenities this area may offer. Del Sol Ave, Santa Barbara]*
3. *The Southeast Botanical Gardens are over the landfill and I hope they do not close them. They are a treasure to me and our community. [Hidden Ln., Palos Verdes Peninsula]*
4. *No golf course! [Briarwood Drive, Torrance]*
5. *Always a dust problem when the wind blows. [Delos Drive, Torrance]*
6. *Yes - please encourage all that are interested in developing the landfill site to treat it for what it is - a pile of contaminated waste that should remain undisturbed for the safety of all. [Briarwood Drive, Torrance]*
7. *I am really concerned with water drain off from the [proposed] golf course and the amount of traffic if the course is approved. [Carolwood Lane, Torrance]*
8. *Is our water drinkable? I buy bottled water because I am afraid there are contaminants in the water. [Briarwood dr., Torrance]*
9. *Before a golf course is built, I'd like DTSC to study movement above ground. The painted pipes split apart exposing the unpainted surface. When they break I hear the vacuum sucking noise. These faults could not be observed/responded too if the pipes were buried. [Crenshaw]*

## California Department of Toxic Substances Control

---

10. *Why are they developing a golf course or planning to anyways when there is so much land movement - it is a pleasant place as an open space - and you have pipes that are still above ground and breaking. I didn't quite understand how anyone can be so stupid as to build something up there. The developer is a liar and did so to my face, so I don't trust him. Via Linda Vista]*
11. *Be honest in your reports and do not "pretend." The more "as long as" phrases you use the less anyone can trust you or your report. Describe worst case scenarios and explain what possibility there is of them happening. Earthquakes, barrier penetration, gas collection machinery breakdown, etc. What will happen if there is a golf course installed with all the watering and real possibility of a barrier penetration? What will the golf course look like? enormous nets? Parking lot will be where? How will this increased traffic affect the landfill? What will happen over time if there is no development? How long is the gas collection machinery expected to last? [Hidden Lane, Palos Verdes Peninsula]*
12. *I do not favor any building or use of the landfill that would use any more water other than rainfall. Construction would also put dust and pollutants in the air. [Briarwood Dr. Torrance]*
13. *Monitor area regularly and after rain storms. Evaluate ooze material. Take appropriate action to protect residents and property. [226th St., Torrance]*
14. *Review detailed water use, groundwater recharge, and slope stability, to evaluate possible connection. It's important to do the study on a small time scale (quarterly - annual water data) and charge time scale (annual, monitor stability). Carolwood Ln., Torrance.*
15. *Concern regarding (water runoff) contamination that could endanger our homes and lives (if golf course approved). [Singingwood dr., Torrance]*
16. *The pipes that circle the landfill are always being replaced because they separate. This landfill is not done moving, and if you walk it every day you can notice different smells all the time! I don't think there should be any question as to whether or not this land should be developed. We have no health problems now... why take a chance. [Moccasin Lane, Rolling Hills Estates]*
17. *Methane gas should not be allowed to escape. Requires us to close all windows when detected. It has happened several times this year. Heard Ralph's market has erosion problems. [Oakwood lane, Torrance]*
18. *Provide data on amount of gas... collected, convert data into dollars, or equivalent, convert BTV prices of imported natural gas... Compute the electrical energy produced by the gas collected. Describe the number of homes that are serviced annually by the gas collected. [Capeswood Dr., Rancho Palos Verdes.*
19. *Will DTSC be doing any testing? Will this be a paper review only? Singingwood Dr., Torrance]*
20. *I hope the proposed golf course will not "illuminate" the hillside under out properties and cause more earth movement. Carolwood Ln., Torrance.*

**Survey Question 5: Did you find the information contained in this fact sheet useful?**

**Note:** The following public comments are unabridged direct quotes.

**Public response:**

Yes	No
31	6

1. *I have a question on page 2, the last paragraph "according to available records" what does that mean? Are there missing records? Please let me know. [Singingwood Dr., Torrance]*
2. *Hope the info. is accurate. [Carolwood Ln., Torrance]*
3. *An informative first! [226th St., Torrance]*
4. *I have read all the fact sheets I have received. [Briarwood Dr., Torrance]*
5. *At least someone is trying to give us information rather than... it so they can get the job done. [Via Linda Vista]*
6. *I want DTSC to interview blue collar workers on the landfill (not administrators!), because they're... to cover up hazards and not discuss them. [Crenshaw]*
7. *Interest focuses both on uses and safety. [Del Sol Ave., Santa Barbara]*
8. *Now I know it is being monitored. [W. Hidden Ln., Palos Verdes Peninsular]*
9. *It's good to know what's going on and why. I own a condo north of the Botanic Gardens. [Palos Verdes Peninsular]*
10. *It is good to understand the history of the landfill and knowing that the government agency is monitoring the site. [Carolwood Ln., Torrance]*
11. *Any info. is good info. [Carolwood Lane, Torrance]*
12. *Thank you for the information about the five-year review. [Briarwood Drive, Torrance.]*
13. *Nothing new that pays attention to logistical effects from the landfill. [Carolwood Ln., Torrance]*
14. *I am afraid the rather vague and conditional language makes me very nervous. For example, "the Palos Verdes Landfill did not raise considerable health risk... as long as the gas collection systems and other safety measures remain effective." WHAT!!!! As long as I am well I should not have a fever. Talk about your self serving comment! [Hidden Lane, Palos Verdes Peninsula]*
15. *Doesn't address the water problem. [Torrance]*
16. *There wasn't much information. [Torrance]*

### 3.0 Geographical location of survey responses

<b>Response from Torrance</b>	<b>Response from Palos Verdes Peninsula</b>	<b>Response from Rolling Hills Estates</b>
<b>25</b>	<b>6</b>	<b>3</b>

<b>Response from Manhattan Beach</b>	<b>Response from Santa Barbara</b>	<b>Response from Rancho Palos Verdes</b>
<b>2</b>	<b>1</b>	<b>1</b>

<b>Response from Hermosa Beach</b>	<b>Response from Country Hills</b>
<b>1</b>	<b>1</b>



***PALOS VERDES LANDFILL  
5-YEAR REVIEW COMMUNITY SURVEY  
RESULTS  
December 2005***



**DEPARTMENT OF TOXIC  
SUBSTANCES CONTROL**

Compiled by: Tim Chauvel, Public Participation Specialist  
and Jeanne Matsumoto, Public Participation Specialist

Department of Toxic Substances Control  
5796 Corporate Avenue  
Cypress, CA 90630





# TABLE OF CONTENTS

	Page
1.0 INTRODUCTION.....	2
SUMMARY OF SURVEY RESULTS.....	2
2.0 SURVEY RESULTS .....	3
SURVEY QUESTION 2: HOW LONG HAVE YOU LIVED IN THE AREA? .....	3
SURVEY QUESTION 3: (PART A) DO YOU WORK IN THE VICINITY OF THE PALOS VERDES LANDFILL (PVLf)?.....	3
(PART B) IF YES, PLEASE ENTER WORK ADDRESS:.....	3
(PART C) PLEASE ENTER THE NUMBER OF YEARS YOU HAVE WORKED AT THIS ADDRESS. ....	4
SURVEY QUESTION 4: (PART A) ARE YOU AFFILIATED WITH ANY LOCAL COMMUNITY ORGANIZATIONS OR AGENCIES? .....	4
(PART B) IF YES, WHAT ARE YOUR ORGANIZATION'S/LOCAL GOVERNMENT'S RESPONSIBILITIES RELATIVE TO THE PVLf? .....	4
SURVEY QUESTION 5: WHAT IS YOUR OVERALL IMPRESSION OF THE OPERATIONS AT THE PVLf? .....	6
SURVEY QUESTION 6: (PART A) HAVE YOU EVER BEEN ON THE PVLf SITE? .....	10
(PART B) IF YES, PLEASE DESCRIBE?.....	10
SURVEY QUESTION 7: WHAT EFFECTS HAVE PVLf OPERATIONS HAD ON THE SURROUNDING COMMUNITY? .....	14
SURVEY QUESTION 8: ARE YOU AWARE OF ANY COMMUNITY CONCERNS REGARDING THE SITE OR ITS OPERATIONS AND ADMINISTRATION? IF SO, PLEASE GIVE DETAILS. ....	18
SURVEY QUESTION 9: ARE YOU AWARE OF ANY EVENTS, INCIDENTS, OR ACTIVITIES AT THE SITE SUCH AS VANDALISM, TRESPASSING, OR EMERGENCY RESPONSE FROM LOCAL AUTHORITIES? IF SO, PLEASE GIVE DETAILS. ....	23
SURVEY QUESTION 10: DO YOU FEEL WELL INFORMED ABOUT THE SITE'S ACTIVITIES AND PROGRESS? .....	24
SURVEY QUESTION 11: ARE YOU AWARE OF ANY SIGNIFICANT CHANGES IN THE LAND USE AROUND THE LANDFILL SINCE 1995? .....	27
SURVEY QUESTION 12: DO YOU HAVE ANY COMMENTS, SUGGESTIONS, OR RECOMMENDATIONS REGARDING THE SITE'S MANAGEMENT OR OPERATIONS? .....	28
3.0 GEOGRAPHICAL LOCATION OF SURVEY RESPONSES .....	36

## 1.0 Introduction

The Department of Toxic Substances Control (DTSC) supervised the mailing of 3,700 fact sheets and community survey questionnaires on May 20, 2005 to residents living within an approximate 0.5 mile radius of the Palos Verdes Landfill. The fact sheet and survey was a follow up to a Five-Year Review fact sheet and survey that was mailed to the community in 2004. The June 2005 fact sheet and questionnaire updated the community on the status of the Five-Year Review process and requested that residents comment on the effectiveness of the landfill safety systems. At the close of the comment period, DTSC had received 94 responses, indicating an approximate return rate of 2.5 %.

Section two of this report shows each survey question followed by unabridged public comment. Name and mailing address details have been omitted in order to protect the identity of survey respondents.

### Summary of Survey Results

Survey Results	No. of Responses
Number of Survey Responses Received	94
<b>How long have you lived in the area</b>	
0-5 years	12
6-12 years	17
13-20 years	8
21 or more years	46

Note: Information shown does not show complete list of survey results, and not all residents responded to all questions.

**Disclaimer:** The self-selected group of people who responded to this community survey questionnaire cannot be viewed as statistically representative of the total population of residents living in close proximity to the Palos Verdes Landfill.

## 2.0 Survey Results

**Number of Survey Responses Received = 94**

### Survey Question 2: How long have you lived in the area?

Public Response:

Years lived in area	0 – 5 years	6 – 12 years	13 – 20 years	21 or more years
Number of responses	12	17	8	47

### Survey Question 3: (Part A) Do you work in the vicinity of the Palos Verdes Landfill (PVLV)?

Public Response:

Yes	No	No Response
17	72	5

### (Part B) If yes, please enter work address:

Public Response:

1. Kaiser Hospital, [Harbour City].
2. Work at home, [Westvale Rd, Palos Verdes Peninsula].
3. 49 Shady Vista Road, Rolling Hills Estates, CA 90274.
4. 25550 Hawthorne Blvd. Torrance, CA 90505
5. Ranch Vista Elementary School, 4323 Palos Verdes Drive North, Rolling Hills Estates, CA 90274
6. In home business, 21 Moccasin Lane
7. 734 Silver Spur Road #306, Rolling Hills Estates
8. 3033 Lazy Meadow Drive, Torrance, CA
9. 2613 Highcliff Drive, Torrance, CA 90505
10. Torrance Memorial Hospital, 333 Lomita Blvd.
11. 37 Ranchview, Rolling Hills Estates, CA 90274

**(Part C) Please enter the number of years you have worked at this address.**

Years worked in area	0 – 5 years	6 – 12 years	13 – 20 years	21 or more years
Number of responses	2	1	1	0

**Survey Question 4: (Part A) Are you affiliated with any local community organizations or agencies?**

**Public Response:**

Survey respondent said <b>YES</b> to Question 4	Survey respondent said <b>NO</b> to Question 4	No response
51	45	4

**(Part B) If yes, what are your organization’s/local government’s responsibilities relative to the PVLFF?**

1. *Palos Verdes Peninsular Horseman’s Association.*
2. *PUC Church, Environmental Network, Sierra Club, Audubon – Maintain for recreational (natural) use for greatest number of citizens and neighbors in safe, healthy, natural way.*
3. *PVP 4-H Club, youth service organization – does community and beach clean-up, have been approached to have a community garden or animal ranch on site for children’s study.*
4. *CAB [Citizens Advisory Board], PACE, South Bay CARES, PVPHA, RHE Equestrian Committee.*
5. *South Bay CARES – I’ve also been working independently – We distribute information about the landfill to local residents.*
6. *PTA/POC Board at Ranch Vista Elementary and the Board at PV Hills Nursery School, both are adjacent to the landfill.*
7. *Sierra Club*
8. *CAB*
9. *CAB, PACE, South Bay CARES, PVPHA, RHE Equestrian Committee.*
10. *CAB: Responsible for commenting on DTSC’s response actions regarding the PVLFF; to facilitate communication and provide information to the local community regarding these comments and actions.*
11. *PACE: Raise awareness about local environmental impacts and potential health effects on the children who live in PV Peninsula & South Bay areas.*
12. *South Bay CARES: oppose development involving irrigation on the landfill.*

## California Department of Toxic Substances Control

---

13. *PTA/POC Board at Ranch Vista Elementary and the Board at PV Hills Nursery School, both are adjacent to the landfill.*
14. *Rancho Vista PTA one of our objectives is to advocate a healthy learning environment for its students.*
15. *Country Hills Homeowners Association – that is in complete opposition to any development of the site because of what it may do to our health, property values, etc.*
16. *I am a member of the South Botanical Garden Trustee.*
17. *So. Bay Epiphyllum Society, Sierra Club. Member of the South Coast Botanic Garden Foundation*
18. *Rancho Vista Elem. School PTA is responsible for ensuring the safety of school children.*
19. *PV Horseman's Assoc.*
20. *CAB - local residents – to help DTSC with community input oversight(?) for PV Landfill*
21. *Member of CAB, Environmental Priorities Network – Our responsibility is to be involved citizens, keeping ourselves and community informed as to the health and safety at PVLf and Hawthorne Sump.*
22. *Member of Citizens Advisory Board for PVLf*
23. *Board of Directors, Estates Townhomes Homeowners Association (adjacent to Botanic Garden)*
24. *I provided comments for the draft EIR for the new South Coast County Golf Course on behalf of South Bay CARES.*
25. *Country Hills Homeowners Association – member*
26. *Citizen's Advisory Committee-Lomita Sheriff's Station-for unincorporated areas. Neighborhood Watch Coordinator-Westfield-300 homes.*
27. *Country Hills Homeowners Assoc. Monitoring & reporting activity to homeowners.*
28. *PVAC – (none), The Estates Homeowners Assoc. (local resident).*
29. *Awareness of concerns of possible contamination of soil-air and ground water.*
30. *Rolling Hills United Methodist Church*
31. *Palos Verdes Peninsula Horsemen's Association, Rolling Hills Estates (peter Weber) Equestrian Center (for recreation)*
32. *Rancho Vista PTA.*
33. *Rancho Vista PTA one of our objectives is to advocate a healthy learning environment for its students.*
34. *Country Hills Homeowners Association – that is in complete opposition to any development of the site because of what it may do to our health, property values, etc.*
35. *I am a member of the South Botanical Garden Trustee.*
36. *South Bay Epiphyllum Society, Sierra Club. Member of the South Coast Botanic Garden Foundation*
37. *Rancho Vista Elem. School PTA is responsible for ensuring the safety of school children.*
38. *Palos Verdes Horseman's Association.*

- 39. CAB - local residents – to help DTSC with community input oversight(?) for PV Landfill
- 40. Member of CAB, Environmental Priorities Network – Our responsibility is to be involved citizens, keeping ourselves and community informed as to the health and safety at PVLf and Hawthorne Sump.
- 41. Member of Citizens Advisory Board for PVLf
- 42. Board of Directors, Estates Townhomes Homeowners Association (adjacent to Botanic Garden)
- 43. I provided comments for the draft EIR for the new South Coast County Golf Course on behalf of South Bay CARES.
- 44. Country Hills Homeowners Assoc – member
- 45. Citizen’s Advisory Committee-Lomita Sheriff’s Station-for unincorporated areas. Neighborhood Watch Coordinator-Westfield-300 homes.
- 46. Country Hills Homeowners Assoc. Monitoring & reporting activity to homeowners.
- 47. PVAC, the Estates Homeowners Assoc. (local resident).
- 48. Awareness of concerns of possible contamination of soil-air and ground water.
- 49. Rolling Hills United Methodist Church
- 50. Palos Verdes Peninsula Horsemen’s Association, Rolling Hills Estates (peter Weber) Equestrian Center (for recreation)
- 51. Rancho Vista PTA [Parent Teacher Association].

**Survey Question 5: What is your overall impression of the operations at the PVLf?**

**Public Response:**

Number of responses to Question 5	No response
83	17

**Note:** The following public comments are unabridged direct quotes.

- 1. Operations are quiet and although I think the area is generally under utilized – I like the way it is. [Rolling Hills Estates]
- 2. Adequate. Rolling Hills Estates – member of Rancho Vista School Parent Teacher Association]
- 3. I am amazed that the County Supervisors want a golf course on a #1 toxic waste dump landfill. It is appalling! [Palos Verdes Peninsula – member of the PV Peninsula Horseman’s Association]
- 4. They seem to be constantly working to find a way out of continuing to oversee the site (by developing it into something else). [Rolling Hills Estates]
- 5. It has caused great community concern for our environment and the health of the individuals as well as wildlife. Preventive measures should

## California Department of Toxic Substances Control

---

- have been taken years ago for this threat from highly toxic waste. [Rancho Palos Verdes – member of PVP 4-H Club Youth Service Organization]*
- 6. Minimum maintenance activities are the primary operations conducted there; since the site no longer generates income from tipping fees and has to import ever-greater quantities of natural gas to compensate for decreasing LF gas production. I feel the San District views this facility as a drain on its resources and has no motivation to be more proactive to protect public health i.e. thinking of ways to improve operations or upgrading the monitoring facilities to meet modern standards.*
  - 7. I feel that the testing is not enough and are there backups if something should fail. [Torrance]*
  - 8. Very secretive. [Rolling Hills Estates]*
  - 9. Suspicion but hope that they do a good job and do not bow to financial motives over community safety and public access. [Rolling Hills Estates – member of Rancho Vista Elementary School P.T.A. & PV Hills Nursery School. [no address given]*
  - 10. Sounds like you are doing a OK job – Keep doing it for the next 15 years at least – Do not allow for a golf course. The comments and information provided by residents and neighbors lowered my assessment of the job you are doing. Maybe the job is fairer. [Lomita – affiliated with PUC Church Environmental Network, Sierra Club]*
  - 11. Operations of PVLF appear to be scaling down. There seem to be less personnel maintaining and repairing the facilities in the past year. [Palos Verdes Peninsula]*
  - 12. They seem satisfactory. [Torrance]*
  - 13. Your description sounds adequate for the needs. [Palos Verdes Peninsula]*
  - 14. So far so good. [Torrance]*
  - 15. Alarming – when there's a spill or very bad odor you call to report it. They ask when it happened and you need to call the day it happens. I know that! [Rancho Palos Verdes – member of Community Advisory Board (CAB)]*
  - 16. It seems to work OK. At least the site doesn't smell bad. [Torrance]*
  - 17. Plans to install a golf course, or any other project that would increase the weight, water, or volume of ground, should be avoided, to assure safety of homes below or near your site. Also possible methane problem as Glendale did. [Rolling Hills Estates]*
  - 18. Only aware of Botanical Gardens and Ernie Howlett Park...favorable. [Rolling Hills]*
  - 19. The landfill is well maintained. [Torrance]*
  - 20. Leave it the way it is! [Rolling Hills Estates]*
  - 21. Doing a good job. [Rolling Hills Estates]*
  - 22. Very well. [Torrance]*
  - 23. Slow process. [Torrance]*
  - 24. It's a big mistake! Don't build on it! [Torrance]*

25. *It seems to be working well and the grounds are kept clean. [Rolling Hills Estates]*
26. *We're glad there's an awareness of the potential dangers to human health. [Torrance]*
27. *Seems to be well run. However some maintenance on road into gardens is in badly need of leveling. Also not enough lights NO Exit sign. [Rancho Palos Verdes]*
28. *It has taken too long a time to control. [Palos Verdes Peninsula – member of South Botanical Garden Trust]*
29. *Concern-% of the removal gases – Rust for first ten years we put up with it. [Rolling Hills]*
30. *Good. We enjoy the view. [Palos Verdes Peninsula]*
31. *Not familiar with other operations besides Botanical Gardens and Recycling Center. [Palos Verdes Estates]*
32. *Have noticed a change out of monitoring – more stations less replacement of above ground pipes. [Rolling Hills Estates]*
33. *Good. [No address given]*
34. *Should stay as it is. [Rolling Hills Estates – member of Rancho Vista Elementary School Parent Teacher Association]]*
35. *Seems OK to me. [Rolling Hills Estates]*
36. *Seems fine. [Palos Verdes Peninsula]*
37. *It's been shut down for many years. Methane gas is burned off. Not aware of any regular activity. [Torrance]*
38. *No problems for me. [Rolling Hills Estates]*
39. *Seems to be run OK on paper and by some reports – quite smooth. In reality problems continue to arise such as locked gates sans emergency personnel and equipment being unable to enter easily, lapses in communication with other agencies i.e. Fire Department.*
40. *Mixed. Little is shared on a regular basis in a consistent forum as to the activities/issues – Is there an annual report? Shouldn't it be mailed to all those who live adjacent to it? [Torrance]*
41. *Good. [Palos Verdes Peninsula]*
42. *I have become aware of the risks involved to public health and safety concerning the operations at PVLf. I feel that agencies involved need to heighten their efforts to make sure nothing is done to increase risks to the community through negligence or future development. [Moccasin Lane – member of CAB]*
43. *Troubleshooting and reactive – not as vigilant or respectful of risk as they should be. Complacency sets in over time. Too great a tendency to presume site is benign. Too much automatic obfuscation w/public. [Rolling Hills Estates – member of CAB]*
44. *When I first moved to my townhome, we had a lot of “dusty” air which caused us to keep windows closed. This situation has improved. I am concerned about potential health risks. While I am not intimately familiar with PVLf operations, my sense is that O&M could be improved with*



- respect to the gas collection system! [Palos Verdes – member of Estates Townhomes Homeowners Association]*
45. *Very good. The grounds are well maintained and the employees are very courteous. [Palos Verdes Peninsula]*
  46. *Seems to be well taken care of. [Torrance]*
  47. *Very professionally maintained and controlled. [Redondo Beach]*
  48. *Very safe and effective. [Rancho Palos Verdes]*
  49. *Seems OK. [Torrance]*
  50. *The PVLFF seems to be safe and poses no hazard to the neighborhood. I have not witnessed any type of danger around area, but I sometimes wonder what would happen if any type of danger does occur. [Rancho Palos Verdes]*
  51. *No problems noted, seems OK. [Rolling Hills Estates – member of County Homeowners Association]*
  52. *Appears to be operating as expected. Nothing out of the “norm” provided we don’t have excessive rain, landslides or movement into adjacent housing or any pipe leaks. [Torrance]*
  53. *Good. [Torrance]*
  54. *Positive. [Torrance]*
  55. *OK. [Palos Verdes Peninsula – member of CAB + Neighborhood Watch]*
  56. *Who knows who can be trusted? [Torrance]*
  57. *Clean & organized. [Torrance – member of Country Hills H.O.A.]*
  58. *Very good - would love to have a golf course!! [Palos Verdes Peninsula]*
  59. *I don’t know! [Torrance]*
  60. *Very responsible. [Rolling Hills Estates]*
  61. *Not sure. [Rolling Hills Estates]*
  62. *Do not have enough knowledge of the PVLFF to comment. [Palos Verdes]*
  63. *Operations seem adequate. [Rolling Hills Estates]*
  64. *I feel the operation has maintained a cautious approach in managing possible dangers to residents in this area. [Torrance]*
  65. *Nothing negative. Have strong opinions about golf course. [Rolling Hills Estates – member of Rolling Hills United Methodist Church]*
  66. *Favorable. [Rolling Hills Estates]*
  67. *OK, I guess. [Rolling Hills Estates]*
  68. *OK. [Palos Verdes Peninsula]*
  69. *Seems to be run ok. [Palos Verdes Peninsula – member of PV Horseman’s Association]*
  70. *I observe ongoing repairs to the big green “header line” pipes, the sink holes, slides, and cracks on the top area where the horse trails are located. [Redondo Beach – member of the Palos Verdes Horseman’s Association]*
  71. *The pipes above ground need to be watched for decay. It’s safe as is – Don’t disturb the toxins. Building will make the air toxic for a minimum of 18 months to 3 years. [Rolling Hills Estates – member of Parent Teacher Association, Rancho Vista School]*

72. *I am on the Country Hills Homeowners Association that is in complete opposition to any development of the site because of what it may do to our neighborhood's health, property values etc. [Torrance – member of Country Hills H.O.A.]*
73. *They are trying. However, with a little more effort the S. Coast Botanical Gardens could be a much greater asset to the county. [Palos Verdes Peninsula]*
74. *The inability to control the smell leaves a poor impression, whether deserved or not. [Rancho Palos Verdes]*
75. *We know very little other than briefly described in this notice. [Rolling Hills Estates]*
76. *The operations seem to be efficiently carried out. Maintenance of the piping and presence of the work force monitoring equipment is obvious. [Rolling Hills Estates]*
77. *On paper, and by some reports – quite smooth. In reality, problems continue to arise such as locked gates stop emergency personnel and equipment being able to enter easily, lapses in communication with other agencies i.e. Fire Department. [Rolling Hills Estates – member of CAB]*
78. *While I am not intimately familiar with PVLF operations, my sense is that O & M could be improved with respect to the gas collection system. [Corvallis – Oregon State University – made comments on EIR for South Bay Cares]*
79. *Ok. [Rolling Hills Estates]*
80. *No opinion. [Torrance]*
81. *No idea? [Torrance]*
82. *Good. [Rolling Hills Estates]*
83. *Positive. [Palos Verdes Peninsula]*

## Survey Question 6: (Part A) Have you ever been on the PVLF Site?

### Public Response:

Survey respondent said <b>YES</b> to Question 6	Survey respondent said <b>NO</b> to Question 6	No response
76	17	7

## (Part B) If yes, please describe?

**Note:** The following public comments are unabridged direct quotes.

1. *Land filled with huge pipes – supposed to control gas emissions but not doing it. Hilly land – trucks coming and going. The smell of gas*

- everywhere. [Rolling Hills Estates – member of PV Horseman’s Association]
2. I have spent time at the horse facilities adjacent to the PVLf site, as well as the Recycle Center. I have also taken walks and ridden horses on the PVLf site. I have visited all areas of the Botanic Garden facility many times. [Torrance]
  3. I use the perimeter trail on average 2-3 times per week; either on foot walking my dogs or riding my horses. I notice the sound of the air entering the header lines due to settlement, usually at the joints. Often this occurs in the same place where I see 3M tape has been previously applied. I often notice strong odors near the NW corner of the perimeter trail near the weather station, where one of the new gas/groundwater collection wells was installed – the odor is especially noticeable after a rain.
  4. Botanical Gardens, Ernie Howlett Park, Horse Stables. [Rolling Hills Estates]
  5. Many times. I live adjacent to it and I and my neighbor often walk there. [Rolling Hills Estates]
  6. Yes, my family uses it regularly to walk around loop. [Torrance]
  7. Botanical Gardens. [Rolling Hills]
  8. Once a week I walk the dogs on site jogging with my dogs for years. I no longer do that because of the response to my call (to report spills or odors). [Torrance]
  9. South Coast Botanical Garden; horse trail that runs along the southern boundary of the landfill; trails on landfill site near Hawthorne Blvd. [Rolling Hills Estates]
  10. Botanical Gardens and E.H. Park [Rolling Hills]
  11. The Botanical Gardens and Howlett Park
  12. I visit the PVLf site about every other week for walks with my dog. [Palos Verdes Peninsula]
  13. I’ve walked the site many times. [Torrance – member of South bay Cares]
  14. Recycling center
  15. Am driving on Crenshaw Blvd. or Hawthorne Blvd. everyday for one reason or another. [Rolling Hills Estates]
  16. Pretty Botanical Garden, pretty public access park/riding areas. [Rolling Hills Estates – member of Rancho Vista Elementary PTA and PV Hills Nursery School]
  17. Visit Botanical Gardens and took trash to the central site when it was still open. [Rolling Hills Estates]
  18. S. Coast Botanical Garden – I enjoy the site with my family and my Girl Scout Troop. [Torrance – member of the Sierra Club]
  19. I take walks there.
  20. I have walked thru several times. [Rolling Hills Estates – member of Rancho Vista Elementary PTA]
  21. Used the landfill when we bought our home in the 1970’s.

22. *Primarily horseback riding on the central site. We occasionally visit the Botanical Gardens. We use Ernie Howlett Park more often. We also utilize the recycling center. [Rolling Hills Estates]*
23. *Yes, when it used to be a dump. [Torrance]*
24. *I take walks on the main site at least 3 times a week. I also visit the small site a few times per year. [Rolling Hills Estates]*
25. *I use the equestrian trail 2-3 times per month. [Rolling Hills Estates]*
26. *A visit to the Botanical Gardens and one to the horse stables with our 2-year-old. [Torrance]*
27. *Use garden – hold Orchid Soc. Meeting 1 month in the evening. [Rancho Palos Verdes]*
28. *Botanic Garden and Ernie Howlett park. [Palos Verdes Peninsula – member of South Botanic Garden Trust]*
29. *I used to walk my dog on park area. [Rolling Hills Estates]*
30. *Botanical Garden. Recycling station. [Palos Verdes Peninsula]*
31. *I use the recycling center every month. [Palos Verdes Estates]*
32. *Ride on landfill with horse 2-3 times a week for the last 15 years. [Rolling Hills Estates]*
33. *I have taken dozens of walks around the site. [Rolling Hills Estates – member of Rancho Vista Elementary PTA]*
34. *Walking on the Loop Trail. [Rolling Hills Estates]*
35. *Parking for the music festival at Chadwick. [Palos Verdes Peninsula]*
36. *Parks, Botanic Garden, horse trails. [Rolling Hills Estates]*
37. *Years ago, it was accessible for refuse disposal. [Torrance]*
38. *I used the land fill until it closed probably 50 times. [Rolling Hills Estates]*
39. *At least 2 times a week I ride my horse there. [Palos Verdes Peninsula – member of the PV Horseman’s Association]*
40. *Very interesting and informative on tour of. Gas to energy facility and general tour of pipes – conduits used in maintaining the landfill. Hopefully “Sanitation District” will be more communicative as we go along. [Rolling Hills Estates – member of CAB]*
41. *As an equestrian, I have ridden the site many times over the years, sometimes on a regular basis. Have volunteered at events held on the site. [Moccasin Lane – member of CAB]*
42. *Walking and driving tours w/ Sanitation Dist + DTSC officials – gives the impression of something to hide. [Rolling Hills Estates – member of CAB]*
43. *I participated in a tour led by the Sanitation District in 2003. [Corvallis OR – affiliated with South Bay Cares]*
44. *My family and I walk our dog around the landfill path. [Palos Verdes Peninsula]*
45. *Been to the South Coast Botanic Gardens annually with our children enjoyed them very much. Now go every three months to turn in my recycle cans, plastic. Paper goes to city of Torrance pickup. [Torrance]*
46. *10K Rolling Hills Run. [Redondo Beach]*
47. *Several times @ Botanic Garden. [Rancho Palos Verdes]*
48. *Daily recreational use. [Torrance]*

49. *We have visited to Botanical Garden several times and often go to Ernie Howlett Park... when they have the annual horse shows; we would have to park at the PVLV site. [Rancho Palos Verdes]*
50. *Botanic Garden – very nice – Recycle Center – very convenient. [Rolling Hills Estates]*
51. *Recycle paper. [Torrance]*
52. *Botanical Gardens. [Torrance]*
53. *Utilized the recycling facility, visited the South Coast Botanic Gardens. [Torrance]*
54. *Botanic Gardens, Recycle Station. [Torrance]*
55. *Walk through on one of my many hikes. [Torrance]*
56. *Horse stables and recycle center.*
57. *I waked around the perimeter a number of times with my dogs. [Palos Verdes Peninsula]*
58. *Rolling Hills 10K. [Torrance]*
59. *Been to the recycle center over the years. [Rolling Hills Estates]*
60. *To the Botanic Garden & used to keep and ride horses on trails (Roanwood).*
61. *I visit the Botanical Garden frequently and have been on the grounds between Crenshaw and Hawthorne twice. Once for parking and once to watch graders working the ground. [Palos Verdes]*
62. *I frequently walk in Ernie Howlett Park and around the periphery of the main site. I visit the Botanic Garden about twice a year. [Rolling Hills Estates]*
63. *Recycle Center usage, 16 yr. history of S.C. Botanic Gardens.*
64. *The Botanic Garden, portions of the Rolling Hills UMC property for which I was a primary worker for some years, the central portion for walking, Ernie Howlett Park for tennis and family activities.*
65. *Visit Botanical Gardens, and stables and Ernie Howlett Park. [Rolling Hills Estates]*
66. *Ernie Howlett Park for sporting events ridden horses, walked around etc, etc. My family rides our horses around the landfill regularly. We walk and ride on the horse trails often.*
67. *Use it for walks, use the recycling center; when landfill was open, used the dump. [Rolling Hills Estates]*
68. *I ride my horses on the landfill several times each week, and I walk my dogs there at least once a week. [Redondo Beach – member of PV Horseman’s Association]*
69. *Hiked on the trail. [Rolling Hills estates – member of Rancho Vista Elementary PTA]*
70. *South Coast Botanic Garden – Visited, taken classes through the garden, and purchased gifts at the gift shop. I have also attended classes and events at the garden.*
71. *I have been to the Botanic Garden several times. [Palos Verdes Peninsula]*

72. *I walk there several times a week with friends, family, and/or my dog. [Rolling Hills Estates]*
73. *From the Botanic Garden to portions of the Rolling Hills UMC property for which I was a primary worker for some years, to the central portion for walking to Ernie Howlett for tennis & family activities. [Rolling Hills Estates – member of RH United Methodist Church]*
74. *Ernie Howlett park is immediately behind my home, so we have attended sporting events there, riding horses there, walked around, etc, etc. My family rides our horses around the landfill regularly. We walk & ride on the horse trails in the area often. [Rolling Hills Estates]*
75. *[I used to visit] The Botanic Garden and kept and rode horses on trails. [Palos Verdes Peninsula – member of Estates HOA]*
76. *Juggling with my dogs for years. I no longer do that because of the above response to my call! [Rancho Palos Verdes – member of CAB]*

## **Survey Question 7: What effects have PVLf operations had on the surrounding community?**

### **Public Response:**

<b>Number of responses to Question 7</b>	<b>No response</b>
<b>86</b>	<b>14</b>

**Note:** The following public comments are unabridged direct quotes.

- 1. People living below the landfill complain about the smell. The market had problems with emissions. Thank god I live above it, not below! [Palos Verdes Peninsula – member of the P.V. Horseman’s Association]*
- 2. Operations are very unobtrusive. I’ve rarely given it much thought even though I utilize the area frequently. [Rolling Hills Estates]*
- 3. Country Hill’s have had concerns about the water table being contaminated & concerns of health and safety. [Torrance]*
- 4. This is what we are trying to get to the bottom of—for example: the fact that neighborhood probes were all but abandoned and never upgraded to reflect current standards leads us to wonder whether the neighbors in close proximity may have been exposed to high levels of VOCs; but, we have no way of knowing since there has been little monitoring of ambient air in these areas. Likewise, for school children. The cooling tower effluent that floats over, around and presumably down into the surrounding areas, has never been tested.*

*No health surveys have been conducted to test whether or not the health of the people who live, work, and recreate on and around the site may have been impacted by it. I believe this type of study is justified due to the fact that this is a unique situation—an unlined, uncapped former class I*

- waste site that has homes built directly adjacent and down gradient, and public schools adjacent. [Palos Verdes Peninsula]
5. Unknown – the community in general doesn't know about "operations". We are concerned about how this site may/will affect us. [Torrance – member of Country Hills HOA]
  6. None that I know of. [Rolling Hills Estates – member of Rancho Vista PTA]
  7. The area below the landfill has experienced problems from underground corrosives migration. [no address given]
  8. Neighboring homes are required stricter building codes to create barriers from possible hazardous run off. Offices and schools in the area have experienced illness, peeling paint and unhealthy air, water. [Rancho Palos Verdes – member of PVP 4-H Club youth organization]
  9. None that I am aware in terms of the normal operations described in this report. A potential golf course would have negative effects on the community. [Torrance – member of Sierra Club]
  10. No one seems to know for sure yet. [Rolling Hills Estates]
  11. So far they have done a good job of mitigating risks and converting the land to good public use. [Rolling Hills Estates – member of Rancho Vista Elementary PTA & PV Hills Nursery School]
  12. I'm not sure but the thought of a conversion to golf course project would be Life Threatening Time – I have asthma and must wear a mask in the garden. [Lomita – member of PUC Church & Environmental Network, Sierra Club & Audubon]
  13. During operation the dust was very bad. [Torrance]
  14. PVLf operations have little current impact on the community. As long as gas collection and groundwater extraction continue to improve. [Palos Verde Peninsula]
  15. Good to my knowledge. [Torrance]
  16. Unknown. [Palos Verdes Peninsula]
  17. So far I haven't noticed any impact. [Torrance]
  18. Serious concern; school (Rancho Vista) built on closed hazardous waste landfill; homes on Rolling Hills Road built on sump that held liquid hazardous waste; homes sliding near Rolling Hills Rd. and Crenshaw. [Rolling Hills Estates]
  19. I hear all the stories from the Torrance residence at town hall meetings. [Rancho Palos Verdes – member of CAB]
  20. It would make a great dog park. [Torrance]
  21. Burn-off Fumes? [Rolling Hills Estates]
  22. Positive alternative natural habitats. [Rolling Hills]
  23. Provides excellent open space for wildlife and people in our community. [Torrance]
  24. There's been many diagnosed with various types of cancer. Have you ever taken a survey? [Rolling Hills Estates]
  25. Nothing bad. [Rolling Hills Estates]
  26. In a positive way. [Torrance]

27. *Some bad odors at first and leakage of methane But overall doesn't appear to be damaging. [Torrance]*
28. *No idea? [Torrance]*
29. *A lot of unusual, unexplained health issues on my block. Ex: cancer – different types, lupus, rare blood disorders – Too numerous to mention. Results-ended in death. [Torrance]*
30. *The Botanic Garden is beautiful and the large site provides open space to the community. There may be some toxic run offs after heavy rains (yellow and brownish froth in the ditches). [Rolling Hills Estates]*
31. *Nice to have open space nearby. [Rolling Hills Estates]*
32. *From our backyard, the green pipes are very visible and we hear the trucks going by every weekday. Otherwise, we believe operations are going well. [Torrance]*
33. *Been good for the community. [Rancho Palos Verdes]*
34. *Needs more fast action to develop the site. [Palos Verdes Peninsula – member of South Botanical Garden Trust]*
35. *I had hopes my wife would see this as planned. -Died in 1989. [Rolling Hills Estates]*
36. *Provides open space which could be used for tree planting. [Palos Verdes – member of South Coast Botanic Garden Foundation & Sierra Club]*
37. *Not known. [Rolling Hills Estates]*
38. *No problem. [no address given]*
39. *None that I know of. [Rolling Hills Estates]*
40. *Minimal (so far) adverse effects; very well used public walking/riding trail. [Rolling Hills Estates]*
41. *Rumors of toxic waste leakage but not proven. [Torrance]*
42. *None that I'm aware of. Maybe some problems in Torrance.*
43. *Unsure. [Palos Verdes Peninsula – member of PV Horseman's Association]*
44. *Recent years – No severe problems – but also community has been ignored or uninformed about problems such as ground water spills into storm drains overflowing 14" extraction wells etc. [Rolling Hills Estates – member of CAB]*
45. *In the late 1950's, the Sanitation District entered into an agreement with the city of Rolling Hills Estates to fill the Hawthorne Sump with garbage, and possibly toxic materials behind our homes on Moccasin Lane. It was a serious mistake. [no address given]*
46. *Noxious fumes, failing wells leading to contaminated plumes. [Rolling Hills Estates – member of CAB]*
47. *Our Homeowners Association has had "monitoring" done from time to time. Is this something you coordinate with our Association? [Palos Verdes – member of Estates Townhomes HOA]*
48. *PVLF operations have caused the community to become concerned about public safety. [Corvallis OR – provided technical comments to South Bay Cares]*



49. *None that are not beneficial as I am concerned. [Palos Verdes Peninsula]*
50. *To my wife and I, think it is very well maintained & looks nice when driving thru area. [Torrance]*
51. *Enhances the area by providing green open space. [Redondo Beach]*
52. *Essentially none. [Rancho Palos Verdes]*
53. *Not sure. [Torrance]*
54. *As far as I know, there hasn't been any effect on the PVLFF operations or the surrounding community. [Rancho Palos Verdes]*
55. *Good. [Rolling Hills Estates – member of Country Hills HOA]*
56. *Day to day operations I don't believe directly affect the surrounding communities. Talks or intent to build a golf course there has the entire community very concerned and scared. Big corporations turned away from it – so should Meritage. [Torrance]*
57. *Negative effects on home site adjacent north. [Torrance]*
58. *None that I am aware of that would be adverse. [Torrance]*
59. *Ernie Howlett Park definite asset. [Rolling Hills Estates]*
60. *An impression only, without proof: The height above sea level of the main landfill has diminished or altered the prevailing westerly winds to our area-N. East of the landfill (empty saddle Club area). [Torrance]*
61. *None that I know of. [Palos Verdes Peninsula – member of CAB]*
62. *I personally do not know of any problems. [Torrance – member of Country Hills HOA]*
63. *a. Methane gas leak into at least one house north of Rolling Hills Rd., between Hawthorne Blvd. & Crenshaw 15-20 years ago.  
b. Corrosion & failure (partial) of electrical system due to deteriorated concrete in structure. Contamination by runoff or leaching from landfill suspected by Ralph's, about 2-3 years ago. [Torrance]*
64. *None that I can see. Nothing bad anyway. [Palos Verdes Peninsula]*
65. *None. [Torrance]*
66. *No effects observed in our area. [Palos Verdes Peninsula]*
67. *Not much that I am aware. [Rolling Hills Estates]*
68. *Not sure – just moved to "The Estates" 2/05. [Palos Verdes Peninsula – member of Estates HOA]*
69. *The only effects I know of are the ones stemming from the garden which would be great pleasure at such an incredible use of landfill. The thought that this treasure could be lost is devastating. [Palos Verdes]*
70. *None that I have observed. [Rolling Hills Estates]*
71. *Prevents further development of open space – keeps density reduced – some adverse effects on trees along Rolling Hills Rd – and on Northern border of main site. [Torrance]*
72. *I used to dump there, toxic concerns on last Crenshaw resurfacing. I have an uphill sample well at street adjacent to my property. [Rolling Hills Estates – member of RH United Methodist Church]*
73. *None to my knowledge other than pleasant facilities for the public. [Rolling Hills Estates]*

74. None that I know of ----except for concern about new golf course. [Rolling Hills Estates]
75. OK. [Palos Verdes Peninsula]
76. Generated controversy, especially with the golf course proposal. [Rolling Hills Estates]
77. It provides recreation. It has contributed to homes sliding. It spews foul odored gas. [Redondo Beach – member of PV Peninsula Horseman’s Association]
78. We are concerned about safety – Neighborhoods have banded together to act as watch dogs – It allows open space to hike and take a dog. [Rolling Hills Estates – member of Rancho Vista Elementary PTA]
79. As long as they maintain the appearance-vegetation, fence and hide ugly buildings on Crenshaw it looks fine. The South Coast Botanic Garden could be so much more! Replant trees on Rolling Hills Road-Please! [Palos Verdes Peninsula]
80. Caused great concern for school children based on increased vulnerability to toxics. [Rancho Palos Verdes]
81. Not to our knowledge. [Rancho Palos Verdes]
82. In the late 1950’s, the Sanitation District entered into an agreement with the City of Rolling Hills Estates to fill the Hawthorne dump with garbage, and possibly toxic materials behind the homes on Moccasin Lane. It was a serious mistake. [Moccasin Lane – member of CAB]
83. Positive. Palos Verdes Peninsula]
84. None that I’m aware of maybe problems in Torrance. [Rolling Hills Estates]
85. The area below the landfill has experienced problems from underground corrosive migration. [Rolling Hills Estates]
86. I know of no negative effects on the surrounding community. Work is carried out with out any interference or inconvenience to the neighborhood and in all the years I’ve lived here, I’ve never known of any reports of a dangerous situation at the landfill nor anyone becoming ill. [Rolling Hills Estates]

**Survey Question 8: Are you aware of any community concerns regarding the site or its operations and administration? If so, please give details.**

**Public Response:**

Number of responses to Question 8	Number of people who stated <b><u>NO</u></b> they were not aware of any concerns	No response
69	13	12

**Note:** The following public comments are unabridged direct quotes.

1. *There have been innumerable protests, organizing to ... it and many very intelligent people and groups and City governments (RHE, RPV ...) have protested. [Palos Verdes Peninsula]*
2. *Some concern that over watering of future golf course will contribute to slope slippage in Country Hills. [Torrance]*
3. *Unreasonable. [Torrance]*
4. *Yes – this one is perfect for the planned golf course.*
5. *Thinking people are opposed to it. (Too many schools nearby). [Rolling Hills Estates]*
6. *We have been involved with several meetings regarding development of the landfill. This is the 1<sup>st</sup> time we have received information regarding operations. [Torrance]*
7. *Adding weight to site might endanger slide risks. Also, Glendale had a severe methane problem when they built golf course over dump, costing millions of dollars. [Rolling Hills Estates]*
8. *A group of groundwater students from UCLA sent out questionnaire on CANCER in the area. This was about 18 months ago. [Torrance]*
9. *Yes, I attend the meetings... to hear from the San. Dist., Toxics – they'll look into our concerns – like they have never heard out questions before. [Rancho Palos Verdes]*
10. *Yes. Concern that proposed golf course will increase subsidence and further spread the existing... contamination. There has been failure by DTSC to protect homeowners and students ON the contamination. [Rolling Hills Estates]*
11. *The community is concerned about future plans to operate a golf course on the site. Status quo seems fine, but any changes to the operation of the site could drastically affect the ability of the PVLFF to prevent the release of hazardous materials or gases. To risk the release of hazardous materials just so there can be one more golf course on the peninsula seems fool hardy. [Palos Verde Peninsula]*
12. *There are toxins in the air and water. I've collected many air samples as well as soil and water. We've given most of the results to DTSC and they seem to dismiss the results. I collected water samples in the gutter at a home in Country Hills. The water was whitish, foamy and was bubbling from the lawn and collecting @ the sidewalk. It had diesel fuel in it. I had to move out of my office because of high levels of acrylonitrile and methylene chloride. [Note: Survey respondent submitted list of compounds found in air samples collected by community member. [Rancho Palos Verdes – member of CAB]*
13. *Containment of liquid waste. [Torrance]*
14. *We are concerned about future plans. [Lomita – member of Environmental Network and Sierra Club]*

15. *Main concern is future use – upheaval of landfill contents to make a golf course then closed to public. Don't bow to big money! Rolling Hills Estates – member of Rancho Vista Elementary School PTA]*
16. *Yes – the potential golf course development. [Torrance – member of Sierra Club]*
17. *The community is very concerned about possible health risks associated with living in close proximity to the site. Also about any future use that may disturb the site. [Rolling Hills Estates]*
18. *I know of an individual who moved her office located near the site to another town to get away from the toxicity found there and evidence of paint peeling off walls in her building. [Rancho Palos Verdes – member of PVP 4 –H Club youth service organization]*
19. *There is massive concern from residents of the area concerning the proposed development of the site into a golf course. It does not take a genius to figure out that adding weight and water to a poorly capped toxic landfill is a dangerous idea. Turning the property into a golf course for the benefit of a few golfers and the county's income is not worth the health or life of even on child (out of several hundred in nearby schools). The contaminates alone that would be put into the air during the course of construction over a several month period far exceeded EPA standards. The risk to hundreds of children and elderly far outweighs the benefit to a few recreational golfers. [Rolling Hills Estates]*
20. *The community surrounding the PVLf is concerned with the potential health risks if the Landfill is developed for any purpose. [Rolling Hills Estates – member of Rancho Vista Elementary PTA]*
21. *Yes, I live in Country Hills and there is a definite concern that we will be on the receiving end of any toxic substances that escapes underground. The treat is real and even more so if that area is developed. [Torrance – members of Country Hills HOA]*
22. *This is what we are trying to get to the bottom of - - for example: The fact that neighborhood probes were all but abandoned and never upgraded to reflect current standards leads us to wonder whether the neighbors in close proximity may have been exposed...*
23. *No – only those pertaining to the central sites use as a future golf course. [Rolling Hills Estates]*
24. *Conversion to golf course/relocation of horse facilities/possible discontinuation of public use for hiking/walking/riding. [Torrance]*
25. *Yes – in my community they are health and traffic. [Torrance]*
26. *I am aware of community concerns, not so much about present operations, but large increase of watering it for a golf course built on the site. [Rolling Hills Estates]*
27. *There is much public confusion as to whether or not development of the site would pose a health hazard. [Rolling Hills Estates]*
28. *(1) In the past month, sewage smells from the corner of Rolling Hills Rd and Crenshaw Blvd., (2) Water run-off after each rain which stays for a few weeks on Oakwood Lane and Rolling Hills Rd. (Green moss and*

- white sediment) (3) Pump trucks on Crenshaw and Hawthorne Blvd. [Torrance]
29. Yes, we hope it will not be necessary to close. [Rancho Palos Verdes]
30. Development of golf course. [Palos Verdes Peninsula]
31. Future traffic on P.V. Dr. is a sad mess; also Crenshaw Blvd. meeting by R.H.E. did nothing to cure this ill. I went to 3 meetings... [Rolling Hills Estates]
32. Yes. Fears of a possible golf course which could only be used by a small part of the public and could possibly cause leaching. [Palos Verdes Estates – member of South Coast Botanic Garden Foundation & Sierra Club]
33. Contaminants in soil that could expose public to health hazards if golf course proceeds. [Rolling Hills Estates]
34. Seepage concerns west of Crenshaw Blvd., land movement. Palos Verdes Peninsula]
35. Concerns about proposed golf course. [Rolling Hills Estates]
36. Parents don't want their preschoolers at R.H. United Methodist to drink the water. Homes on north side of landfill are possibly part of a cancer cell. [Rolling Hills]
37. Concerns about toxic waste leakage among certain elements, concerns of air quality, water seeping. [Torrance]
38. Golf course development and its effect on the community. [Palos Verdes Peninsula – member of PV Horseman's Association]
39. Yes – Concerns about possible health hazards to children at school adjacent or near the landfill. Community warning system in case of disaster affecting landfill cap should be in place ASAP. None exists as yet to my knowledge. [Rolling Hills Estates – member of CAB]
40. Yes. Placement of a golf course on the site – All neighbors that I have spoken with think this is foolish regardless of the preventative actions taken. Development of such a site that requires high volumes of water is irresponsible. Landfill should be left alone. No "Love Canal" [Torrance]
41. See CAB agenda. [Rolling Hills Estates – member of CAB]
42. Our homeowners are anxious to see the results of your Five-Year Review [Palos Verdes – member of Estates Townhomes H.O.A. (adjacent to Botanic Gardens)]
43. The community is concerned about exposure to hazardous substances from the landfill, particularly VOCs. They are also concerned about potential damage due to seismic events and landslides. [Corvallis OR – made comments on EIR for South Bay CARES]
44. Water/soil runoff into the Country Hills development. [Redondo Beach]
45. Yes, by local environmentalists who do not have any real basis for objections? [Rancho Palos Verdes]
46. Yes – Various Homeowner Associations have weighed in over the years. [Torrance]

47. *Cancer cases in our community – some rare forms sometimes bad smell in the air. My pets are dying much younger than they used to – (cancer) [Eastvale Rd., Palos Verdes Peninsula – member of CAB]*
48. *Excessive water may have caused the landslide in Country Hills. [Torrance – member of Country Hills HOA]*
49. *To a limited degree – mainly what I read in the paper. [Palos Verdes Peninsula]*
50. *Yes, air and water pollution. [Palos Verdes Peninsula]*
51. *Only what I have read in the local newspapers, including letters to the editor. [Rolling Hills Estates]*
52. *Best example was Crenshaw resurfacing a few years ago. Concern for children’s health at the RHUMC. [Rolling Hills Estates – member of Rolling Hills United Methodist Church]*
53. *I have only heard of concerns regarding runoff from a proposed golf course. I personally favor a golf course. [Rolling Hills Estates]*
54. *Only as it relates to being able to safely turn the landfill into a golf course.*
55. *Fear of hazardous waste migrating to other areas. [Rolling Hills Estates]*
56. *Yes, understand that golf course is being considered. It would be a terrible shame to lose such a lovely quite place in our neighborhood. [Palos Verdes Peninsula]*
57. *Plans to develop a golf course with its continual need for water are a concern. Keep the horse trail and “natural” habitat. No more development! [Torrance]*
58. *Every so often I read something in the paper about someone who has a problem. Don’t know who Joan Davidson is but she seems to have problem from time to time. [Rolling Hills Estates]*
59. *Questions or concerns about future changes, such as the proposed golf course. [Torrance]*
60. *I am concerned about the proposed golf course and... impact on the health of local residents. [Rolling Hills Estates – member of Estates HOA]*
61. *I have seen monitoring at the entrance to our Condo complex, so I have some concern that this monitoring is being done properly. I was unaware that I could access info. at the library. [Palos Verdes]*
62. *Homeowners adjacent to site are concerned about lateral movement of methane into properties. [Torrance]*
63. *Landslides, water seeping out of the hillside into the Country Hills Homes’ yards. Gas extraction pipes that are visible above ground melt and break and there are plans to put them underground for the golf development. Terrible gas odors fill the Country Hills neighbor hood. [Redondo Beach – member of PV Peninsula Horseman’s Association]*
64. *Yes, after the discovery of the deterioration when Crenshaw was repaired, it made us worry about other pipes. [Rolling Hills Estates – member of Rancho Vista Elementary School PTA]*
65. *Golf course problems and concerns. The golf course is not a good idea given slope/run-off problem. [Palos Verdes Peninsula]*

66. *Only that some members of the community are concerned about disturbing the soil for possible development of the site which could result in releasing hazardous gases. I share that concern. [Rolling Hills Estates]*
67. *Numerous citizens of Torrance, Rolling Hills Estates, Rancho Palos Verdes, Palos Verdes Estates, and Lomita expressed concerns about potential out gassing and overflow. [Rancho Palos Verdes]*
68. *There are concerns that continued monitoring is not in place to detect high temperatures underground that may indicate combustion. Also ... toxins may be migrating off the site and into the community. Contaminated ground water is a concern whether it is ingested or not. It will go somewhere. [Moccasin Lane – member of CAB and Environmental Priorities Network]*
69. *Yes. I have attended many of the meetings concerning the intent to build a golf course there and the landslides into housing, as well as acidic groundwater at the shopping center that also runs into housing and storm drains. [Torrance]*

**Survey Question 9: Are you aware of any events, incidents, or activities at the site such as vandalism, trespassing, or emergency response from local authorities? If so, please give details.**

**Public Response:**

Number of responses to Question 9	Number of survey respondents who stated <b>NO</b> to Question 9	No response
14	67	13

**Note:** The following public comments are unabridged direct quotes.

- I am not aware of any issues of vandalism or trespassing. [Palos Verdes Peninsula]*
- No – however, many speakers, especially woman in ... provided many specific examples – Dr. Debbie Oudiz. [Torrance - survey comment made at June 8, 2005 public meeting]*
- We have seen Fire Dept. and hazmat personnel on the site, but have no idea why. [Rolling Hills Estates]*
- No, I am not aware of it. [Rolling Hills Estates]*
- RHE Park has had some problems. [Torrance]*
- I have seen people drive trucks up to dump stuff off on the roll offs – refuse not green waste from site. [Empty Saddle Rd, Rolling Hills Estates]*
- (1)Groundwater spills – Oct 2003 to storm drain. (2) Elevated temperatures in some monitoring wells into ... fire range. (3) Overflowing*

- extraction well – (new 14') during rain storm. Rolling Hills Estates – member of CAB]*
8. *Fire Dept. had difficulty accessing site apparently. [Rolling Hills Estates]*
  9. *At times, homeless people camp at the landfill. [Torrance – member of Country Hills HOA]*
  10. *When a small fire was reported after hours nobody on site would open the gates for the Fire Department. They had to clime a fence to get inside. [Redondo Beach – member of PV Horseman’s Association]*
  11. *I have seen helicopters circling looking for a lost child...strange question. [Palos Verdes Peninsula]*
  12. *No, in my experience the site is a tranquil area, alive with wildlife, not vandals or the like. Being off the beaten path, it is not too accessible to the general public. Unless you live near by, you don’t even know its there. [Rolling Hills Estates]*
  13. *Until the Emergency Response Program was begun, access in emergencies was of great concern. Please continue to communicate with all responsible agencies on a regular basis. [Moccasin lane – member of CAB]*
  14. *I have heard about the documented reports of leaks in the ground, pipe bursts etc. All not related to any vandalism or trespassing. The land moves, the pipes move, the cracks in the ground leak nasty stuff. It’s a hazardous waste dump! [Torrance]*

**Survey Question 10: Do you feel well informed about the site’s activities and progress?**

**Public Response:**

<b>Number of written responses to Question 10</b>	<b>Number of survey respondents who stated <u>YES</u> they feel well informed</b>	<b>Number of survey respondents who stated <u>NO</u> they do not feel well informed</b>	<b>No response</b>
<b>48</b>	<b>24</b>	<b>20</b>	<b>2</b>

**Note:** The following public comments are unabridged direct quotes.

1. *Not in the last few weeks, but we are constantly alert about the activities there. [Palos Verdes Peninsula – member of PV Horseman’s Association]*
2. *Need more info on development of golf course and horse riding trails. [Torrance]*
3. *Not really, this review sheet is first I have seen concerning site. [Rolling Hills Estates]*
4. *Progress to what goal. I’m against the golf course. Too much water on a toxic landfill. [Rolling Hills Estates]*



5. *Some what informed. [Rolling Hills Estates]*
6. *Not well enough. Meetings are planned but not advertised to the entire community – word of mouth spreads quickly, but not as quickly as open honest advertising. [Torrance]*
7. *Now I do [after receiving fact sheet] [no address given]*
8. *I do not think so. [Palos Verdes Peninsula – member of South Botanical Garden Trust]*
9. *No, but we've only been here one year. We're planning to go to the Community Town Hall meeting as well. [Torrance]*
10. *This is the first information we have received regarding maintenance. Do you have a website? [Torrance]*
11. *Semi [informed].*
12. *The answers are we'll look into this! [Rancho Palos Verdes – member of CAB]*
13. *Adequate. [Torrance]*
14. *I do not feel well informed of the site's progress. [Palos Verdes Peninsula]*
15. *Yes, because I collect my own data. [Torrance – member of South Bay CARES]*
16. *Maybe.*
17. *No – much better after tonight. [Torrance - survey comment made at June 8, 2005 public meeting]*
18. *Not through PVLF. I know of your activities only through a grassroots coalition of parents/residents. [Rolling Hills Estates – member of Rancho Vista Elementary School PTA]*
19. *Relatively informed – this report [fact sheet] helps. I am interested on information regarding the proposed golf course project. [Torrance – member of Sierra Club]*
20. *Not until now [after receiving fact sheet] [no address given]*
21. *No, certainly no progress. I did hear of a proposed plan to make it better, but in my opinion is not good enough for the level of... at this site. [Rancho Palos Verdes – member of PVP 4-H Club]*
22. *Somewhat informed. [Rolling Hills Estates]*
23. *The review update [fact sheet] is informative; however this is the only document I think I have received from the PVLF. There have been public meetings, however if you cannot make it to the meeting you do not receive information. [Rolling Hills Estates – member of Rancho Vista Elementary School PTA]*
24. *This is the 1<sup>st</sup> piece of info. I have received in 3 years. I am very concerned about leaks (i.e. possible health risks), and would like more frequent updates. [Torrance – member of Country Hills H.O.A.]*
25. *Fairly well informed. This is the first mailer I recall receiving. However, goings on are generally well reported in the local newspaper. [Rolling Hills Estates]*
26. *Only as it pertains to the Botanic Gardens. [Palos Verdes Estates – member of South Coast Botanic Garden Foundation]*

27. *Takes effort to dig out information about problems, hopefully more cooperation from landfill operating agency will be forthcoming in discussing ongoing problems and their solutions or mitigation. [Rolling Hills Estates – member of CAB]*
28. *No. Again, no regular and consistent distribution of the sites maintenance and operational activities have been communicated. [Torrance]*
29. *Yes, but I'm on the CAB, so I make it a point to be informed. [Rolling Hills Estates]*
30. *I think I need to be better informed. [Palos Verdes]*
31. *So, so. [Redondo Beach]*
32. *We hear what the agencies want us to hear. Not necessarily the truth. [Torrance – member of Country Hills H.O.A.]*
33. *Yes, but a map [in the fact sheet] would have been helpful. [Torrance]*
34. *Plenty of opportunities – I haven't got to it. [Rolling Hills Estates]*
35. *Moderately well informed. [Rolling Hills Estates]*
36. *I don't receive any info on the sites progress other than what I read in the local newspaper. I am assuming that's because there is nothing out of the ordinary to report. [Rolling Hills Estates]*
37. *Yes [more informed] (after reading this review) [Palos Verdes Peninsula]*
38. *Yes, we get a couple of reports a year. [Torrance]*
39. *Can I trust any government agencies test results? [Torrance]*
40. *Nothing other than the South Bay Breeze. [Rolling Hills Estates]*
41. *Not sure – new residents. [Rolling Hills Estates – member of Estates H.O.A.]*
42. *This is the first communication that I am aware of, so I would have to say I feel not well informed, but I may have inadvertently missed other notices. [Palos Verdes]*
43. *No. I think that landfill workers are in denial with regards to the safety of the site. They're constantly fixing the same problems in the same places. The horse trail continues to sink and the ground cracks while pipes melt and break. [Redondo Beach – member of PV Horsemen's Association]*
44. *I belong to the South Coast Bot., Garden Association. [Palos Verdes Peninsula]*
45. *No – the homes in Country Hills receive quarterly news letter – R.H.E. homeowners don't. [Rolling Hills Estates – member of Rancho Vista Elementary School PTA]*
46. *After receiving this packet, yes. Thank you for the information. I appreciate being able to offer my thoughts about the site and being informed about the site's activities & progress. [Rolling Hills Estates]*
47. *It is unclear that the PVLF has made progress toward relocating or identifying the contents. Current mitigation practices are not sufficient. [Rancho Palos Verdes]*
48. *I feel much more informed since becoming a member of the CAB. When we moved here in 1972, we had no idea the landfill contained toxins, much less that we had garbage in our backyard, some toxic. [Moccasin Lane – member of CAB]*

## Survey Question 11: Are you aware of any significant changes in the land use around the landfill since 1995?

### Public Response:

Number of written responses to Question 11	Number of survey respondents who stated <b>NO</b> they were not aware of any significant changes	No response
30	56	8

**Note:** The following public comments are unabridged direct quotes.

1. *The landfill is constantly moving – Crenshaw Blvd., is always resurfacing the street beside the landfill etc. [Palos Verdes Peninsula – member of PV Horsemen’s Association]*
2. *Only squabbles about developments. [Torrance]*
3. *More planting - no longer a eye sore. [Palos Verdes Peninsula]*
4. *1950 I used to hunt with a gun on property for 2 yrs. So you see a lot of changes have happened. Also, I was member of L.A. gun club. (Shot gun only). [Rolling Hills Estates]*
5. *More soil added, huge pipes above ground. [Rolling Hills Estates]*
6. *Additional housing. [Torrance]*
7. *I’d watched dirt being brought in to fill the holes from shifting or settling the ground. [Rancho Palos Verdes – member of CAB]*
8. *The proposed golf course. [Rolling Hills Estates]*
9. *Many trees were cut on the landfill site. [no address given]*
10. *Hearing about a golf course development. [Torrance]*
11. *It seems there are many more large trucks dumping soil on the landfill. [Palos Verde Peninsula]*
12. *Haven’t many homes been built? Also all the toxic spills – leaks. [Lomita, member of Environmental Network]*
13. *Land slippage in Country Hills area – (upper area) [Rolling Hills Estates, San Miguel Rd.]*
14. *Just proposed changes. [Torrance]*
15. *Yes, oozing of gunk into local market. You claim it had nothing to do with the landfill. Also, acids corroding power lines under ground making power go off. BLACKOUT. [Torrance, Winlock Rd.]*
16. *Many trees were cut on the landfill site just over our fence (in a strange fashion) and we’re not sure of the reason(s). [Torrance, Briarwood Drive]*
17. *No, other then at the Botanic Gardens. [Palos Verdes Estates]*
18. *No – other then locking of gates. [Rolling Hills Estates – member of CAB]*
19. *I have seen more landscaping planted. [Palos Verdes]*
20. *More trees, vegetation. [Redondo Beach]*
21. *The air is cleaner. [Torrance]*
22. *More homes. [Palos Verdes Peninsula]*

- 23. *Nothing detrimental. [Palos Verdes Peninsula]*
- 24. *Area is pretty much built out. [Torrance]*
- 25. *The stable has unstable ground – barns sink, arena footing shifts, some gas extraction has been installed. The water and sewer lines break underground. [Redondo Beach – member of PV Horsemen’s Association]*
- 26. *Pipes seem more exposed – I don’t know if that is true or just my perception. [Rolling Hills Estates – member of Rancho Vista Elementary School PTA]*
- 27. *No, other than seeing more of the community enjoying the open space for riding, hiking, etc. [Rolling Hills Estates]*
- 28. *The number of children in the local communities that transit Crenshaw, Hawthorne and PVDN has increased. [Rancho Palos Verdes]*
- 29. *I have been concerned about damage to homes and businesses below the northern border in Torrance. [Moccasin Lane – member of CAB]*
- 30. *Yes, land slides, ground cracks, pipe leaks and cracks/breakage. Acidic ground water running through drains and storm drains etc... [Torrance]*

**Survey Question 12: Do you have any comments, suggestions, or recommendations regarding the site’s management or operations?**

**Public Response:**

Number of responses to Question 12	No response
77	17

**Note:** The following public comments are unabridged direct quotes.

- 1. *Leave the landfill undisturbed, landscape it, have it open space, equestrian and ... people use – that doesn’t stir up that poisoned ground. The Sierra Club has made this their plan for that landfill. [no address given]*
- 2. *[Letter attached to community survey sent to DTSC on June 2, 2005] Thank you, for the opportunity of providing input to your COMMUNITY INTERVIEW QUESTIONNAIRE regarding the Palos Verdes Landfill.*

*I am the original owner and occupant of 3206 Carolwood Lane, Torrance California located in the Country Hills Development. I purchased my home in 1976 when it was just a “lime mark” on the ground and moved in November 1977. Our back yard chain link fence is the common fence we share with the Palos Verdes Landfill.*

*I have experienced almost all of the phases of the landfill development from the approximate 200 foot hole in ground behind our property to its current elevation of 200 feet above our property. I have experienced all of*

*the dust entering our home, flying trash and smell of Methane gas up until its closure and landscaping in the early 80's. I personally experienced the mud slide of 1978 caused by heavy rains and improper drainage. I was there when Prince Charles turned down the landfill as a venue for the 1984 Olympic Equestrian event.*

*I currently live directly across the street from the hillside homes at 3201 – 3205 Carolwood Lane which experienced the landslide in 2001.*

*Overall, I have to say that I am happy with the Palos Verdes Landfill as my neighbor. I have a 180 acre nature reserve out my back door. Over the years and often on a daily basis, I can go into my backyard in the morning with a cup of coffee and see Hawks, falcons, Sparrows, Swallows, Humming Birds, Ravens, Blue Jays, Orioles and even an Eagle. At night I can see Raccoons, Skunks, Opossums, Squirrels and even a small Deer. In my back yard I have Lizards, Snakes, Kangaroo Rats burrowing Tarantulas, giant Black Widow spiders, Wasps, Black Bumble Bees and Yellow Jackets. Currently I have two active bird nests, one Dove and the other a Sparrow. Just two weeks ago I had a young male Peacock in my back yard. This is the first Peacock I have seen west of Crenshaw in the 27 years I have lived there.*

*So you can see I'm generally happy. However, I would like to make a few suggestions to improve our neighborly relationship.*

- 1) Help us clean up the bush and shrubbery on our common chain link fence. I can cut and clear from my side, but I can't go over the barbed wire to clean on your side.*
- 2) Whenever the chain link and barbed wire fence is accidentally damaged by trucks and other heavy equipment on the utility road on the Landfill side of the fence, please make repairs in a timely manner.*
- 3) Send an engineer to inspect the properties on the south side of Carolwood Lane. Particularly those near the land slide area. In the past 12 months (and before the heavy rains of 2005) the properties appear to be buckling. There is a 3 cm buckle appearing in two locations on my property which was not there a year ago. This appears to be the result of the pressure of the Landfill mountain pushing up against the restraints of the retaining walls/barriers constructed on the north side of Carolwood Lane.*
- 4) Finally, encourage/educate the Country Hills Home Owners Association to repair and /or install proper rainfall drainage systems on their homes. Many homes do not have proper rain gutter systems to remove rain from their homes. Those homes that have "French"*

*drains under their property have not been cleaned in years or have disconnected drains. Much of the problems have occurred as a result of the turnover of homeowners who have not lived on the hill. As well as the several years of nominal rain fall prior to 2005. You would think that the events in Laguna and Anaheim Hills would be an adequate warning to the residents of Country Hills and its neighbor Palos Verdes Landfill.*

*Thank you, for the opportunity to provide this response to you. I hope that I might hear from you soon. [Carolwood Lane, Torrance]*

- 3. I would like to see the golf course built. It was a plan when I purchased the house. [Carolwood Lane, Torrance]*
- 4. Results from the gas monitoring probes and other testing should be posted on a public website. I'm in favor of keeping the site open for horseback riding and hiking. [Rolling Hills Estates]*
- 5. What's new about the proposed golf course? [Rolling Hills Estates]*
- 6. No problems noted. [Rolling Hills Estates]*
- 7. The landfill appears to be well maintained. Thank you for this mailing, it provided our family with a lot of good information. We are concerned with impacts to our environment due to the hazardous materials dumped in the landfill. [Torrance]*
- 8. The area would be a great dog park during the day. [Torrance]*
- 9. Why is Don ... so determined to make this a golf course? [Rancho Palos Verdes]*
- 10. County Sanitation District should NOT serve as the lead agency to clean up its own contaminated site. Moreover, groundwater data indicates that hazardous waste has leaked from the site. County San. appears to be taking no action to halt the contamination. DTSC would not tolerate ongoing GW contamination of this nature from a private industrial site. County San. has been allowed to ignore the problem it created. [Rolling Hills Estates]*
- 11. I am very concerned about the proposed golf course development. Won't construction on this site lead to possible hazardous waste exposure? What safeguards and monetary guarantees are in place if disaster strikes from such a development? How can we stay informed of all developments? [Torrance]*
- 12. Help keep it open space – no golf course. [Rolling Hills Estates]*
- 13. [No comment] Not at this time. [Rolling Hills Estates]*
- 14. Not at this time. [Torrance]*
- 15. While the gas collection and groundwater extraction are in place, there still appears to be an abnormally high rate of health issues that could be potentially associated to the PVLFF in the Country Hills area directly down stream of the PVLFF. [Palos Verde Peninsula]*
- 16. I feel the PVLFF should continue to improve on methods to contain hazardous gases and materials. Protection of health and lives of the*

- families that live in the surrounding communities should be the primary directive of the PVLf. [Palos Verde Peninsula]*
17. *This site is not managed properly and the agencies are miss-representing the problems. The methane-to-gas center needs to be replaced. A prescriptive, engineered cover needs to be placed and the site needs to be converted to non-irrigated activities. There is contaminated groundwater flowing offsite. (1) Borings to determine where contaminated groundwater is (2) Vapor intrusion studies in all homes and businesses surrounding PVLf (3) Health study to determine which residents are ill and the diseases they have. Tell the truth. [Rancho Palos Verdes]*
18. *[Leave] Open to public use. [Torrance]*
19. *Have trails and trees not golf courses and goop and gas. Any disruption of soil in the landfill will endanger the life of every adult and child who has asthma. Are you willing to provide heppa filters, face masks or gas masks for every adult especially for every child in all the surrounding schools who has asthma? 5,000 people die every year from asthma attacks – (I believe this is CA stats). Even one additional death (especially of a child) would be a crime. Plans include actions and procedures. Monitoring and testing and spot checking includes ongoing logs. Final report should include daily (even hourly) tests in graph and table form and your spot check data should match exactly. Summary and average data are interesting but daily monitoring graphs are most... meaningful. [Lomita]*
20. *Do not sacrifice – public safety – public access to park land for big \$ and a golf course. [Rolling Hills Estates]*
21. *We would hope that the interests of the people who live near and/or go to school near the site would be the primary concern of the agencies operating the site. Developers and bit money interests should NOT take precedence over the health and safety of local residents. At the meeting on June 8<sup>th</sup>, it was apparent that DTSC does not know everything that the Sanitation District is doing at or near the site. Several residents mentioned monitoring of household (inside) air and indicated that some houses actually had monitoring devices installed by the Sanitation District. Also, it seemed that residents were able to find, and present, documents related to the site that DTSC had never seen. Specific questions were answered with vague generalities or “bureaucratic speak” which only served to further the mistrust of the agencies involved. Do people need to die first? After all this time, we felt that it would have been appropriate for DTSC to talk about specific results instead of making promises to “look into the issues” or do yet another “study” of the problem. Almost an hour was wasted, at the opening of the meeting, with a slide presentation of the printed agenda which everyone had a copy of and was perfectly capable of reading for themselves. DTSC needs to get a handle on this site before a disaster strikes so that residents feel assured that any and all potential problems can and will be handled correctly. [Rolling Hills Estates]*

22. *Is there a community warning system in place in the event of a leak or emergency? What to do in case of an earthquake? Thank you. [Torrance]*
23. *More testing (scheduled) – backups. [no address given]*
24. *As a resident of Rolling Hills Estates, I am extremely concerned about the toxicity of the PV Landfill. I am not in favor of developing the site into a golf course. It needs to be left alone with continued close monitoring and the highest preventative environmental standards employed. [Rolling Hills Estates]*
25. *I have read in the paper that there is an approved (?) plan to develop a golf course, is this true? And how does this affect the various aspects of the DTSC Plan? Who does DTSC report to? If it's the Sanitation District, who do they report to? I have personally observed and smelled methane (?) leaks at the Botanic Gardens on various occasions. What's that about? One of the charts displayed shows "No data 1952 – 72" what does this mean? Does that mean the 23 tons and 3 -4 % hazardous waste estimates are bogus?[no address given]*
26. *I understand funding is available to see that a proper cap is put on this, not the sludge cake as present. Every conceivable precaution should be put into place to keep the community safe. Why doesn't the LA Sanitation District use it's 71 million dollar disposal/surcharge fund to fix this site by putting in more wells, pipes and an improved new gas-to-energy centre that is not polluting our air. It needs to be made safe first before it can be used for any recreational other use. [Rancho Palos Verdes]*
27. *The community voted very overwhelmingly to leave the landfill as a managed open space. I don't see any good reason to change that. [Rolling Hills Estates]*
28. *Yes – do whatever it takes to keep the toxic underground substances from leaking. There is a huge community of people that will be directly affected in Country Hills... Please also support us in opposing the golf course. I can't imagine that being more important than the health etc, of the surrounding residents. I suggest sponsoring ground water testing in surrounding neighborhoods and communicating results on a periodic basis. [Torrance]*
29. *You are doing a fine job. The area is well maintained, clean and safe. I would like to have equestrian/pedestrian access to the area west of the stable and east of Hawthorne Blvd. I know that you've used it occasionally for horse show parking and events, but why is it not available for regular day use? [Rolling Hills Estates]*
30. *Leave it the way it is! [Torrance]*
31. *DON'T BUILD ON IT! [Torrance]*
32. *No, the management and operations of both sites seem to be going well. There should not be a golf course built on the main site. Many established trees would be removed and the large amount of watering the grass will create toxic runoffs. [Rolling Hills Estates]*



33. *We'd like to be more informed about the site and operations. Hopefully, the review and this type of community communication can be more frequent than every 5 years. [Torrance]*
34. *We as a society always give most of our money we raise at our fall show to the gardens. Never seem to see any improvements being made. Still same old bumpy road at entrance. At night cannot find exit – no light exit sign. We give about \$1000 to \$1500 the site use. [Rancho Palos Verdes]*
35. *Please do some action ASAP. [Palos Verde Peninsula]*
36. *Traffic – on Palos Verdes Drive North is a big problem. I hope in your studies and planning can cure this ill. [Rolling Hills Estates]*
37. *The site should only be developed as open space for trails and other uses by the public in general. [Palos Verdes Estates]*
38. *A golf course is the perfect use for this land. [no address given]*
39. *Leave the site alone – no development! [Rolling Hills Estates]*
40. *The landfill as currently operated provides public recreational opportunities and seems to be under proper control as concerns toxic waste. Construction of a golf course on top will change the status quo in unknown and potentially devastating ways, and should be disallowed. [Rolling Hills Estates]*
41. *Not aware of management activity. [Torrance]*
42. *I look forward to the golf course! [Rolling Hills Estates]*
43. *Do not develop this spot into a golf course. 1<sup>st</sup> – we do not need another golf course. 2<sup>nd</sup> – we do not need to risk stirring up chemicals that shouldn't even be there. 3<sup>d</sup> – as evidenced by gas production causing air pockets on Crenshaw this site is not “inactive.” [Palos Verdes Peninsula]*
44. *As noted in comments – (1) Better communications with other agencies – such as Fire, Police etc who should be familiar with landfill problems, solutions, dangers, toxicity etc., and have easy entry to the grounds. (2) Community warning system in case of disaster or hazardous discharges at the landfill. (3) If at all possible maintain the landfill in the present state with little or no disturbance of the surface other than maintaining the cap; monitoring for spills or “plumes” and quickly mitigating any problems that arise. [Rolling Hills Estates]*
45. *Yes (1) develop and distribute a quarterly report and include (A) Maintenance activities... (B) Monitoring results (C) Future plans (quarterly, annually, etc) (2) Post information on website (3) Conduct annual survey of local residents and post results on website (4) Restrict use and allow no additional development of site [Torrance]*
46. *Site must be totally characterized, contained + honestly evaluated and left alone to go through biological processes to become less volatile. Concerns also re- land movement at northern end into Torrance should be seriously evaluated. [Rolling Hills Estates]*
47. *Is it possible for our Homeowners Association to receive a copy of the Five-Year Review when it is complete? [Estates Townhomes H.O.A., Palos Verdes]*

48. *If it hasn't done so recently, the Sanitation District should evaluate cap integrity and gas collection system... The District should also prohibit any redevelopment uses which require substantial irrigation. [Corvallis, OR]*
49. *I'm in favor of pursuing the proposed golf course use. [Redondo Beach]*
50. *...Let's get on with the much needed golf course. [Rancho Palos Verdes]*
51. *Still favor a County operated golf course. [Torrance]*
52. *A condition of the initial landfill approval was the construction of a golf course on the site. What is the status, and why? [Rolling Hills Estates]*
53. *I think a golf course would be nice. I am not a golfer. [Palos Verdes Peninsula]*
54. *Leave it as it is. Don't build on the site! [Torrance]*
55. *Let's get back to the "hope" for a golf course. [Torrance]*
56. *Is it still going to be a golf course? [Torrance]*
57. *Continues monitoring should be mandatory. [Rolling Hills Estates]*
58. *Yes, I think random houses surrounding the dump should have the water in their homes tested by an independent firm for the presence of dioxins, chemicals, pesticides, metals etc. [no address given]*
59. *[I have] golf course comments only. [Rolling Hills Estates]*
60. *I would like to see the land developed further for recreational use by the public. [Rolling Hills Estates]*
61. *Keep it open space. No golf course. We don't need any more traffic, but do need parks. [Rolling Hills Estates]*
62. *Please update issues and changes more frequently. [Rolling Hills Estates]*
63. *Yes, could the gate along the horse trail be opened @ 7:00 am? I often am disappointed that the gate is closed and miss my walk around the landfill. [Palos Verde Peninsula]*
64. *Just continue what has been done in the past. Hope the golf course is still in the plans. [Torrance]*
65. *Please continue to inform all PV and Torrance residents regarding the PVLF operation. We appreciate your concern towards the residents. [Rancho Palos Verdes]*
66. *My major concern is about health – 4 occurrences of cancer on our street + 1 lupus + 1 Parkinson's. These are the ones I know of. Who knows how many others? Coincidence, I don't know. Thanks for your concern. [Torrance]*
67. *The "South Coast Botanic Garden" appears to be the "step child" of the L.A. County's Botanic Gardens. Years ago the local Botanic Garden appeared a lot more attended to and cared for: Plants were better labeled, trimmed and maintained, the lane appeared a lot cleaner and the stream down from the lake was running and pumped back up, had minimal life etc. etc. The "Arcadia" L.A. County Botanic Garden is a beautiful showpiece in comparison (the admission fees are the same). Are our tax dollars not as valuable here?? [Torrance]*
68. *There has been talk of building a golf course over the landfill which I think is a wonderful idea. Something along the lines of Mountain Gate in the*

- Sepulveda Pass would be a fine addition to the community. [Rolling Hills Estates]*
69. *As stated, I am opposed to the building of a golf course. Also, since I used to board a horse on Rosewood in approximately 1960 – 78, I observed “Judy McCray” w/cancer/ neighbor to the left of her house died of cancer/neighbor to the right of her ill w/cancer, got breast cancer. At Seahorse Riding Club in the 1980’s Julie martin died of cancer age 21. That’s a lot of cancer in a very small radius – though you’d be interested in that. [Rolling Hills Estates]*
70. *Would be in opposition to development of land as golf course. It seems it would be an advantage or appropriate use of unstable ground, in addition to creating greater traffic congestion to this heavily traveled area. Personally, I do not like to be awakened by traffic @ 0500 – or breathe in the fumes of the traffic which drift up this street. (Crest Road, Torrance)*
71. *Don’t hide the toxic landfill under the guise of a golf course. It needs constant repairs to the visible problems. Don’t dismiss the trained workers and don’t bring in golf developers. Toxic substances should be monitored and maintained by toxic danger trained staff. [Redondo Beach]*
72. *I feel the landfill is well maintained and safe as is. Any disruption will result in massive toxins being released into the air. I’m not satisfied with comments such as... “it’s only for 12-24 months.” That is at least 1 year – more like 3-4 years of my child, my family, my friends, neighbors and community breathing poison. Not acceptable! I want assurance that you’re checking existing pipes and that landfill water isn’t ending up in the storm drains. I want the buried pipes kept buried. Add topping if necessary. [Rolling Hills Estates]*
73. *1) A park and South Coast Botanic Garden are fine. In fact, even more development of the S. Coast Bot. garden would be nice – picnic, tea garden, etc. This could be a real County asset! 2) No golf course, please! No driving range. No projects that can endanger the slopes or increase traffic. 3) On Crenshaw: East side – Since there does not appear to be space for an attractive wooden white fence – is there anyway to improve the appearance of the chain link fence – paint or something. It appears rusted in parts. West side: Recycle activities or construction equipment needs to be better hidden or maintained. Looks bad traveling north. 4) Rolling Hills Rd., - Recently removed trees need to be replaced with something. Also, this whole side of the S.C. Bot. garden could really use an upgrade. [Palos Verdes Peninsula]*
74. *I would like to see things continue as they have. The area is an asset to the community as it provides open space which hikers, equestrians, nature lovers can all enjoy. I have always felt safe there and feel assured that the site is being properly monitored and maintained for hazardous gases. I think it is marvelous that a toxic waste dump could be turned into a beautiful, safe and productive (gas to energy) area, as it has at PVLf. [Rolling Hills Estates]*

75. *Suggestion/recommendation: Use subsurface core samples to identify all materials and ... of liquids in subsurface cores. Create “physical” profile of finding and map composition of PVLFF for public review. Until a comprehensive understanding of PVLFF content layers can be evaluated, no adequate analysis can be performed. [Rancho Palos Verdes]*
76. *(1) Please institute an independent review system, separate from, and in addition to, that of the Sanitation District, starting immediately with this 2005 Five-Year Review. We could call it “a second opinion.” It would make the whole process more credible. (2) Please consider how the proposed golf course development would impact the ability of the Sanitation District to properly monitor and maintain this very sensitive site. Please consider the difficulties they would have with the planned lines and irrigation systems to have full access to the site. Please consider how any disturbance to the site would affect all of us, near and far. Thank you, again for this opportunity to meet and confer... Thanks again for your unflagging professionalisms ... to everyone. ... What I conclude from the speakers is that we really need you to stay independent and stay on our side. We really need you to be here for us, and I believe you are. Thanks again! [Moccasin Lane]*
77. *I believe the site should continue as it is a “semi-dormant” hazardous waste dump site. Continue monitoring and maintaining the site and honestly publicize everything! Do not allow any company to develop the site. No golf course, No development. Continue business as usual. Thank you. [Torrance]*

### 3.0 Geographical location of survey responses

Response from Rolling Hills Estates	Response from Torrance	Response from Palos Verde Peninsula
30	26	15

Response from Rancho Palos Verdes	Response from Redondo Beach	Response from Lomita
5	2	2

Response from Palos Verdes Estates	Response from Corvallis, OR	Location of response not stated
2	1	11

### Map showing location of survey responses

The map on the next page shows the location of survey responses (dots) in relation to the Palos Verdes Landfill.

**Palos Verdes Landfill Five-Year Review Community Survey Results**

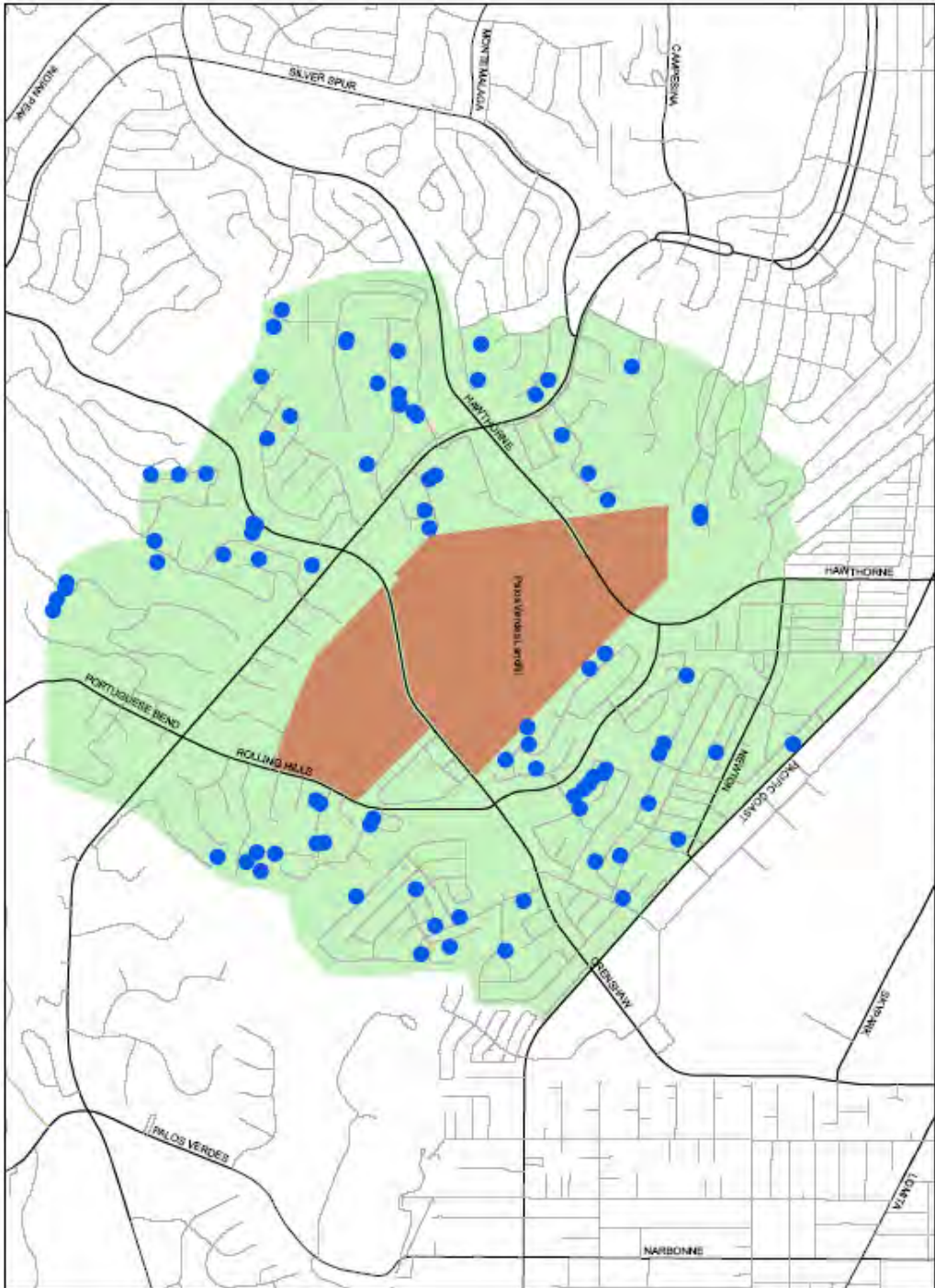

<p><b>Legend</b></p> <ul style="list-style-type: none"> <li><span style="color: blue;">●</span> Survey Response Address Locations (86 Locations Shown)</li> <li><span style="background-color: #8B4513; width: 20px; height: 10px; display: inline-block;"></span> Palos Verdes Landfill</li> <li><span style="background-color: #90EE90; width: 20px; height: 10px; display: inline-block;"></span> Mailing Boundary</li> </ul>	
	<p>0 495 990 1,485 Feet</p> <p>Scale: 1:10,000</p>
<p><small>Copyright 2010. All rights reserved. This information is provided as a courtesy and may not be reproduced or used in any form without the express written permission of Digital Map Products, Thomas Bros. Maps</small></p>	

# APPENDIX F

## 16th Street Watershed Runoff Use Project – City of Santa Monica

*Initial Study/*  
*Mitigated Negative Declaration*  
*for*  
**Penmar Water Quality Improvement Project**  
**W.O. EW40019\***



*City of Los Angeles*



*Bureau of Engineering*  
*Environmental Management Group*

**May 15, 2009**

**CITY OF LOS ANGELES**  
OFFICE OF THE CITY CLERK  
ROOM 395, CITY HALL  
LOS ANGELES, CALIFORNIA 90012  
**CALIFORNIA ENVIRONMENTAL QUALITY ACT**  
**MITIGATED NEGATIVE DECLARATION**  
(Article I, City CEQA Guidelines)

<b>LEAD CITY AGENCY AND ADDRESS:</b> Department of Public Works, Bureau of Engineering 1149 South Broadway, Suite 600, Los Angeles, CA 90015-2213	<b>COUNCIL DISTRICT</b>  11
---	-----------------------------------

<b>PROJECT TITLE:</b> <b>Penmar Water Quality Improvement Project (W.O. EW40019*)</b>	T.G. 671-H4 to J4 & J5
--	------------------------

**PROJECT LOCATION:** Penmar Recreation Center (1341 Lake Street), Penmar Golf Course, Frederick Street north of Rose Avenue, Rose Avenue from Frederick Street to just north of Penmar Avenue, Oakwood Avenue between Millwood Avenue and Rialto Court, Rialto Court south of Nowita Place, Crescent Place between Rialto Court and Palms Boulevard, and Abbot Kinney Boulevard at the intersection with Palms Boulevard, in the Los Angeles community of Venice.

**DESCRIPTION:** The proposed project consists of the construction of a stormwater diversion structure, primary and secondary pump station systems, a pretreatment system to screen trash, sediment, oil and grease; an underground detention reservoir, and three force mains for flow conveyance. Phase II of the project would provide further treatment for beneficial use for landscape irrigation at Penmar Golf Course, Penmar Recreation Center and/or Marine Park. Diverted flows would be conveyed to a pump station constructed within Frederick Street right-of-way northwest of the intersection with Rose Avenue. As sewer capacity allows, a portion of the diverted flow, including dry weather flow would be diverted directly to the sanitary sewer via a force main from the proposed pump station to the sanitary sewer and ultimately to the Hyperion Treatment Plant. Another portion of the wet weather flow would be diverted via a second force main to an approximately 2.75-million gallon reservoir beneath the Penmar Recreation Center Field 5. Stormwater stored in the reservoir would be held for approximately seventy-two (72) hours after a storm event passes and then discharged at a controlled rate to the sanitary sewer through a combined gravity and pump system that would be constructed adjacent to the reservoir. The project also includes minor sanitary sewer upgrades on Oakwood Avenue between Millwood Avenue and Rialto Court, on Rialto Court south of Nowita Place, Crescent Place between Rialto Court and Palms Boulevard, and on Abbot Kinney Boulevard at the intersection with Palms Boulevard. Implementation of this project would help the City meet Santa Monica Bay Beaches Dry & Wet Weather Bacteria Total Maximum Daily Loads (TMDLs) adopted by the Water Quality Control Board to protect the designated beneficial uses of the receiving waters. The project is funded by Proposition O, a \$500 million Clean Water Bond Measure approved by voters November 5, 2004.

**NAME AND ADDRESS OF APPLICANT IF OTHER THAN CITY AGENCY:**

**FINDING:**  
The **City Engineer** of the City of Los Angeles has determined that this project will not have a significant effect on the environment for the following reasons: **See attached initial study.**

**SEE THE ATTACHED PAGES FOR ANY MITIGATION MEASURES IMPOSED**

Any written objections received during the public review period are attached, together with the responses of the lead City agency.

**THE INITIAL STUDY PREPARED FOR THIS PROJECT IS ATTACHED**

<b>PERSON PREPARING THIS FORM</b> Maria Martin Environmental Supervisor	<b>ADDRESS</b> 1149 S. Broadway, Suite 600 Los Angeles, 90015-2213	<b>TELEPHONE NUMBER</b> (213) 485-5753
---	--	---

<b>SIGNATURE (Official)</b> Ara Kasparian, Ph.D., Manager Environmental Management Group	<b>DATE</b> 5/18/09
--	------------------------

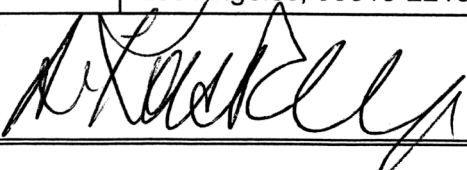





CITY OF LOS ANGELES  
CALIFORNIA ENVIRONMENTAL QUALITY ACT  
**INITIAL STUDY**

Council District: 11 Date: May 15, 2009  
Lead City Agency: Department of Public Works, Bureau of Engineering  
Project Title: Penmar Water Quality Improvement Project

## **I. INTRODUCTION**

### **A. Purpose of an Initial Study**

The California Environmental Quality Act (CEQA) was enacted in 1970 for the purpose of providing decision-makers and the public with information regarding environmental effects of proposed projects; identifying means of avoiding environmental damage; and disclosing to the public the reasons behind a project's approval even if it leads to environmental damage. The Bureau of Engineering Environmental Management Group (EMG) has determined the proposed project is subject to CEQA and no exemptions apply. Therefore, the preparation of an initial study is required.

An initial study is a preliminary analysis conducted by the lead agency, in consultation with other agencies (responsible or trustee agencies, as applicable), to determine whether there is substantial evidence that a project may have a significant effect on the environment. If the initial study concludes that the project, with mitigation, may have a significant effect on the environment, an environmental impact report should be prepared; otherwise the lead agency may adopt a negative declaration or mitigated negative declaration.

The Mitigated Negative Declaration (MND) and Initial Study (IS) contained herein have been prepared in accordance with CEQA (Public Resources Code §21000 et seq.), the State CEQA Guidelines (Title 14, California Code of Regulations, §15000 et seq.), and the City of Los Angeles CEQA Guidelines (1981, amended July 31, 2002).

### **B. Document Format**

This MND is organized into eight sections as follows:

Section I, Introduction: provides an overview of the project and the CEQA environmental documentation process.

Section II, Project Description: provides a description of the project location, project background, and project components.

Section III, Existing Environment: provides a description of the existing environmental setting with focus on features of the environment which could potentially affect the proposed project or be affected by the proposed project.

Section IV, Environmental Effects/Initial Study Checklist: presents the City's Checklist for all impact areas and mandatory findings of significance. Includes discussion and identifies applicable mitigation measures.

Section V, Mitigation Measures: provides the mitigation measures that would be implemented to ensure that potential adverse impacts of the proposed project would be reduced to a less than significant level.

Section VI, Preparation and Consultation: provides a list of key personnel involved in the preparation of this report and key personnel consulted.

Section VII, Determination – Recommended Environmental Documentation: provides the recommended environmental documentation for the proposed project; and,

Section VIII, References: provides a list of reference materials used during the preparation of this report.

### **C. CEQA Process**

Once the adoption of a negative declaration (or mitigated negative declaration) has been proposed, a public comment period opens for no less than twenty (20) days or thirty (30) days if there is state agency involvement. The purpose of this comment period is to provide public agencies and the general public an opportunity to review the initial study and comment on the adequacy of the analysis and the findings of the lead agency regarding potential environmental impacts of the proposed project. If a reviewer believes the project may have a significant effect on the environment, the reviewer should (1) identify the specific effect, (2) explain why it is believed the effect would occur, and (3) explain why it is believed the effect would be significant. Facts or expert opinion supported by facts should be provided as the basis of such comments.

After the close of the public review period, the Board of Public Works considers the negative declaration or mitigated negative declaration, together with any comments received during the public review process, and makes a recommendation to the City Council on whether or not to approve the project. One or more Council committees may then review the proposal and documents and make its own recommendation to the full City Council. The City Council is the decision-making body and also considers the negative declaration or mitigated negative declaration, together with any comments received during the public review process, in the final decision to approve or disapprove

*INITIAL STUDY  
PUBLIC WORKS – BUREAU OF ENGINEERING*

the project. During the project approval process, persons and/or agencies may address either the Board of Public Works or the City Council regarding the project. Public notification of agenda items for the Board of Public Works, Council committees and City Council is posted 72 hours prior to the public meeting. The Council agenda can be obtained by visiting the Council and Public Services Division of the Office of the City Clerk at City Hall, 200 North Spring Street, Suite 395; by calling 213/978-1047, 213/978-1048 or TDD/TTY 213/978-1055; or via the internet at <http://www.lacity.org/CLK/index.htm> .

If the project is approved, the City will file a notice of determination with the County Clerk within 5 days. The notice of determination will be posted by the County Clerk within 24 hours of receipt. This begins a 30-day statute of limitations on legal challenges to the approval under CEQA. The ability to challenge the approval in court may be limited to those persons who objected to the approval of the project, and to issues which were presented to the lead agency by any person, either orally or in writing, during the public comment period.

As a covered entity under Title II of the Americans with Disabilities Act, the City of Los Angeles does not discriminate on the basis of disability and, upon request, will provide reasonable accommodation to ensure equal access to its programs, services, and activities.

## II. PROJECT DESCRIPTION

### A. Location

The main elements of the proposed project are located within Frederick Street north of Rose Avenue, Rose Avenue from Frederick Street to approximately 500 feet northeast of the intersection with Penmar Avenue, and within Penmar Recreation Center, a multi-use City of Los Angeles park located at 1341 Lake Street in the community of Venice. The project also includes minor sanitary sewer upgrades on Oakwood Avenue between Millwood Avenue and Rialto Court, on Rialto Court south of Nowita Place, Crescent Place (pedestrian walk) between Rialto Court and Palms Boulevard, and on Abbot Kinney Boulevard at the intersection with Palms Boulevard. Phase II proposes stormwater beneficial use at Penmar Golf Course, Penmar Recreation Center, and/or Marine Park. Refer to Figures 1 and 2.

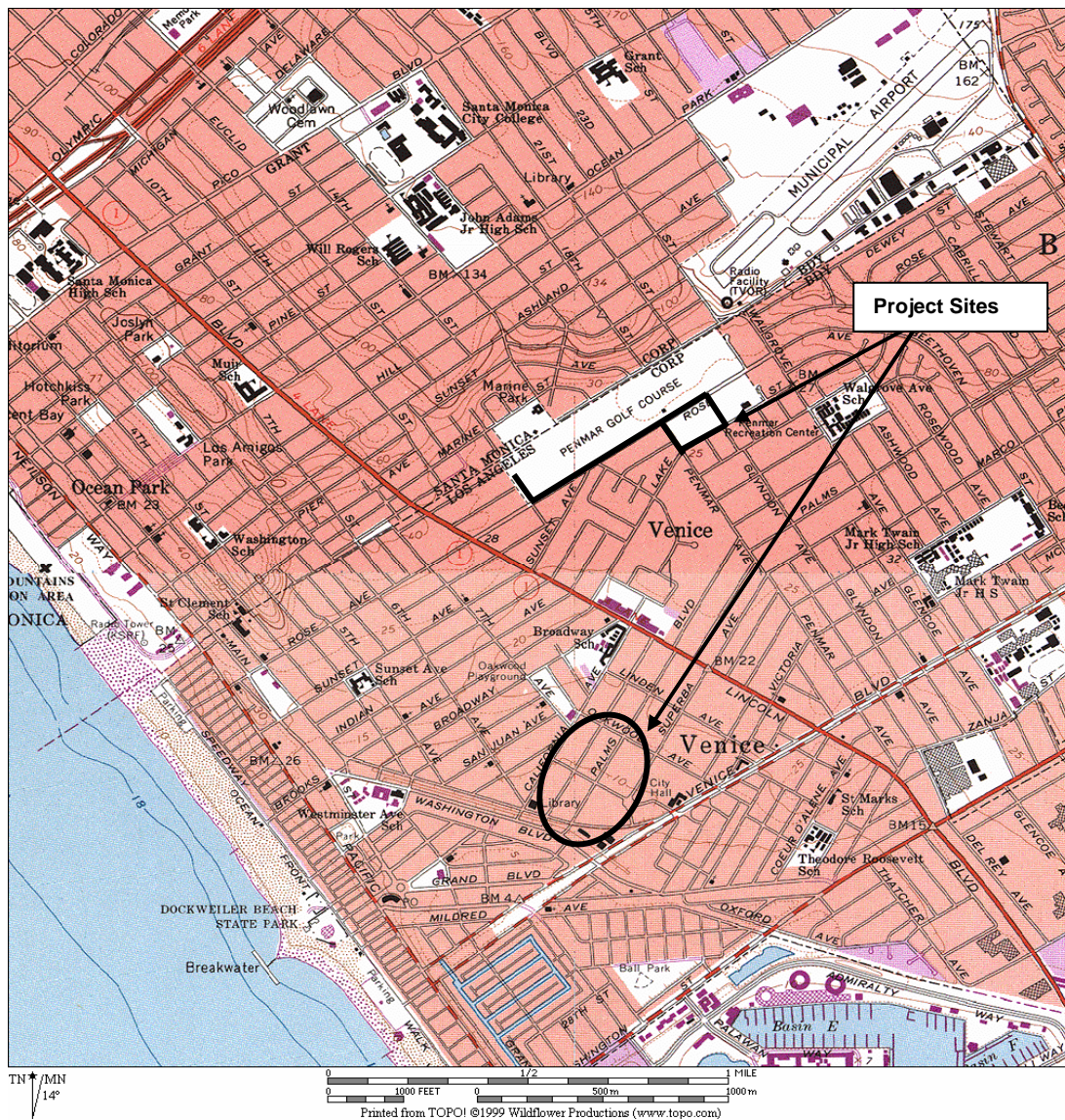

Figure 1: Project Vicinity

INITIAL STUDY  
PUBLIC WORKS – BUREAU OF ENGINEERING



Figure 2: Project Location

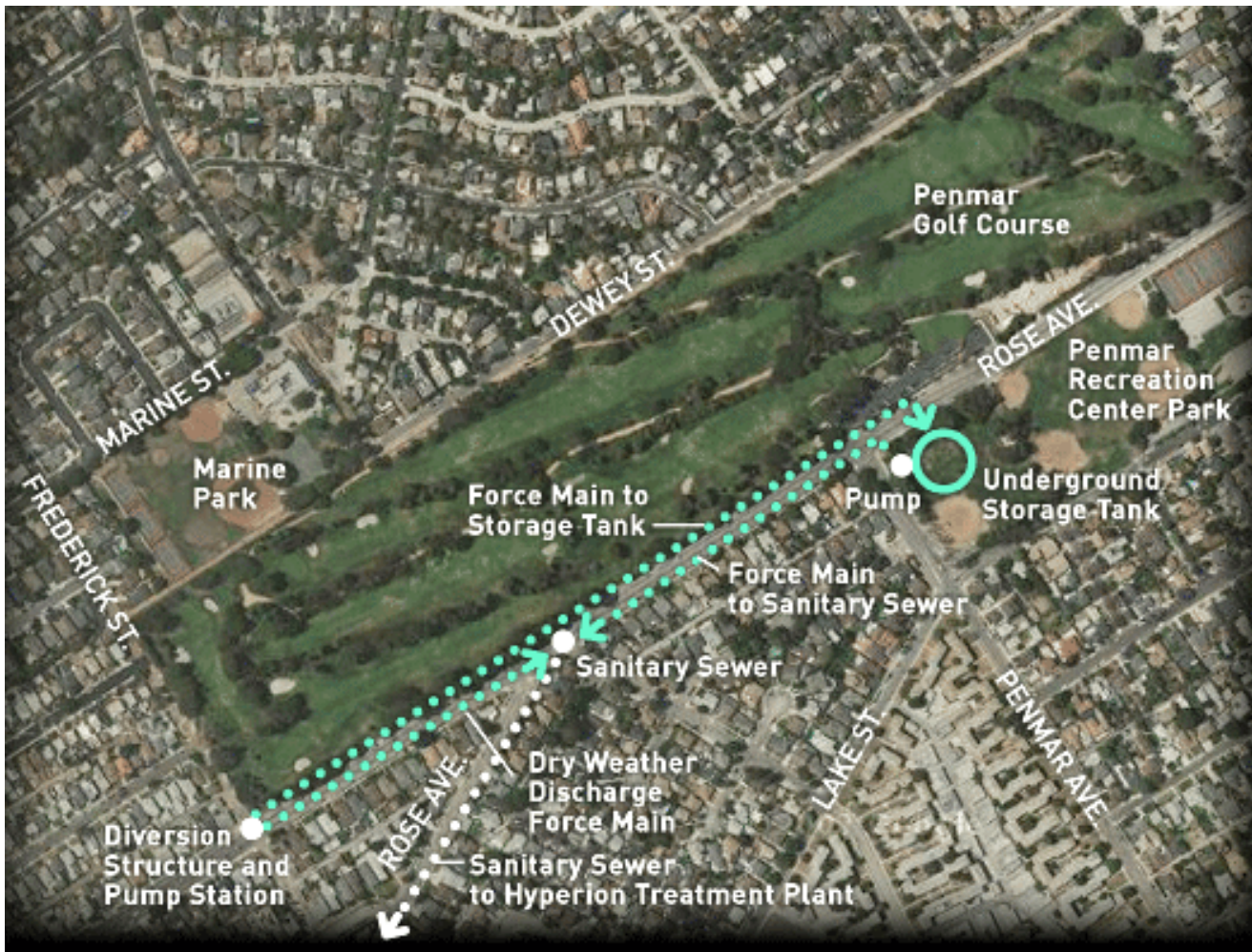

Figure 3: Proposed Layout (Main Elements of Phase I)

## B. Background

The Clean Water Act (CWA) of 1972 is the governing federal regulation for water quality in the United States. The CWA provides the legal framework for several water quality regulations, policies and programs, including National Pollutant Discharge Elimination System (NPDES), effluent limitations, water quality standards, pretreatment standards, anti-degradation policy, non-point source discharge regulation, and wetlands protection. The United States Environmental Protection Agency (USEPA) has delegated the responsibility for administration of portions of the CWA to the states, which are required to develop a list, known as the 303(d) List, of impaired water bodies within their jurisdictions and the pollutants for which they are impaired. The states must then establish a total maximum daily load (TMDL) (a maximum limit for a specific pollutant that a water body can receive and still meet water quality standards) for the listed pollutants of each impaired water body found within its region (Technical Steering Committee 2004).

The Santa Monica Bay beaches were designated as impaired and included on California's 1998 CWA 303(d) list of impaired waters due to excessive amounts of coliform bacteria. High bacteria concentrations in surface waters is an indication that water quality may not be sufficient to maintain the beneficial use of these waters for human body contact recreation (REC-1) (Technical Steering Committee 2004). The Santa Monica Bay Beaches Wet Weather Bacteria (SMBBWWB) TMDL adopted by the Los Angeles Regional Water Quality Control Board (LARWQCB) became effective July 15, 2003 and includes a number of interim compliance goals beginning in the fall of 2009. This TMDL was incorporated as an amendment to the regional Water Quality Control Plan (Basin Plan). The Basin Plan designates beneficial uses for surface and ground waters, sets narrative and numerical objectives that must be attained or maintained to protect the designated beneficial uses and conform to the state's anti-degradation policy, and describes implementation programs to protect all waters in the Region.

The SMBBWWB TMDL encompasses 27 areas (sub-watersheds) that drain into the Santa Monica Bay. There are twenty-five (25) storm drains that discharge runoff from some portion of Los Angeles to Santa Monica Bay beaches. The City has embarked upon several projects to reduce the amount of bacteria-laden stormwater runoff that drains into Santa Monica Bay. The proposed project location was selected based upon project sites identified in the *Santa Monica Bay Beaches Wet Weather Bacterial TMDL Implementation Plan* (City of Los Angeles et al. 2005) and is one of various projects identified in the implementation plan intended to reduce bacteria levels along the local shoreline.

The proposed Penmar Water Quality Improvement Project is located within the Santa Monica Bay Watershed and targets a drainage area of approximately 1,468 acres (Figure 4) that drains into the existing Los Angeles County (the County) Storm Drain in Rose Avenue (henceforth referred to as the Rose Avenue Storm Drain) which ultimately drains to the Santa Monica Bay via an outlet located at the end of Rose Avenue at

INITIAL STUDY  
PUBLIC WORKS – BUREAU OF ENGINEERING

Venice Beach. Urban runoff draining from this tributary area contains numerous pollutants with potential to degrade water quality and contribute to frequent exceedances of beach water quality standards that cause a significant number of beach closure days. Currently, the pollutants of primary concern are fecal indicator bacteria, which are believed to be an indicator of pathogens that pose potential human health risks in the receiving waters. The proposed project would assist in improving water quality and would support the City’s efforts to comply with current and future stormwater regulations for Santa Monica Bay beaches.

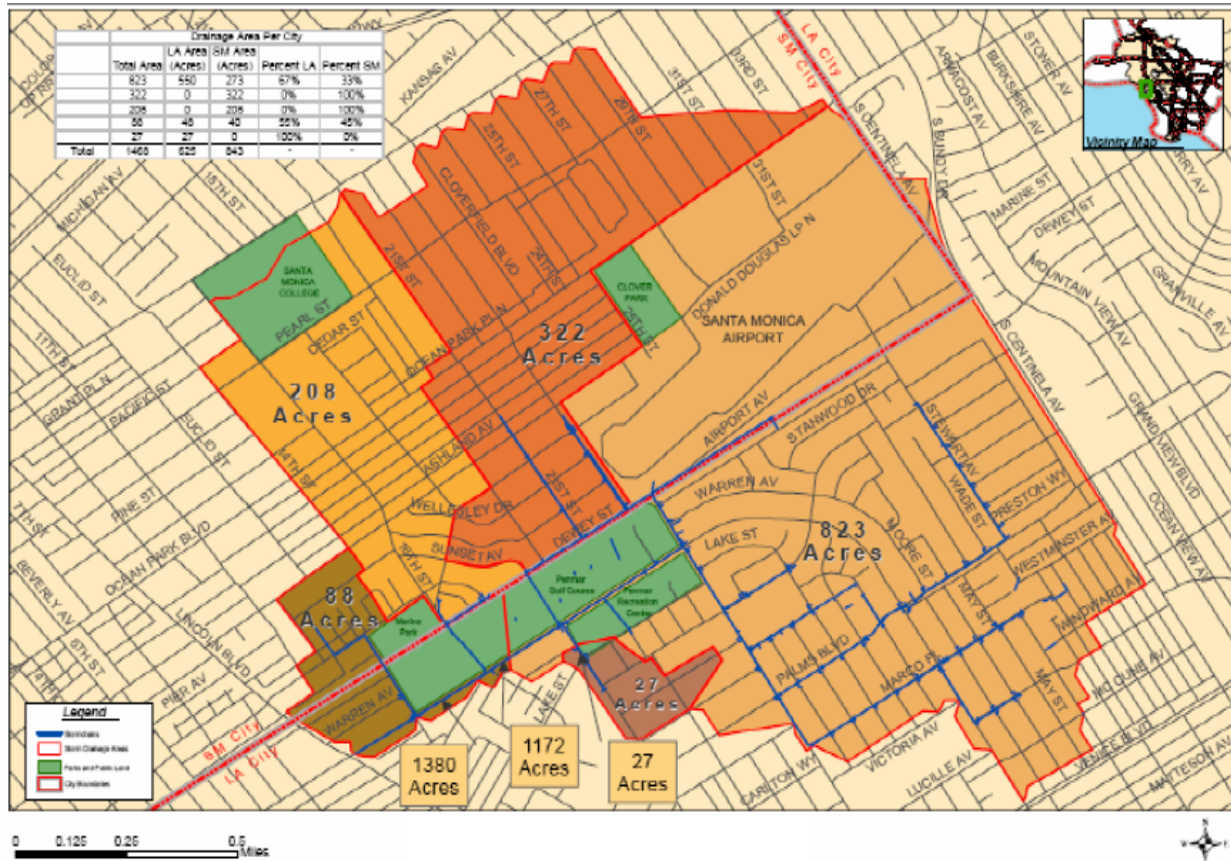

Figure 4: Penmar Water Quality Improvement Drainage Area



### **C. Purpose**

The Penmar Water Quality Improvement project is funded by Proposition O, which was passed by the voters of the City of Los Angeles in 2004. Proposition O authorized the City of Los Angeles to issue a series of general obligation bonds for up to \$500 million for projects to protect public health by cleaning up pollution, including bacteria and trash, in the City's watercourses, beaches and the ocean, in order to meet Federal Clean Water Act requirements. In addition, the measure provides funds for improvements to protect water quality, provide flood protection, and increase water conservation, habitat protection, and open space.

The main purpose of the proposed project is to reduce the amount of pollutants (including bacteria, oil and grease, and suspended solids) during both dry and wet weather and to improve water quality in the receiving waters. The main goals of the project are to increase the beneficial and recreational uses of the receiving waters, reduce potential risks to human safety and health, reduce beach closures, and preserve aquatic and marine habitat. Phase II of the project includes stormwater beneficial use for landscape irrigation.

### **D. Project Description**

#### **Project Overview and Background**

Surface runoff from approximately 1,468 acres surrounding the project area (Figure 4) drains into the Rose Avenue Storm Drain and ultimately to the Santa Monica Bay via an outlet located at Venice Beach. This runoff has the potential of introducing pollutants (bacteria, oil and grease, suspended solids, metals, gasoline, and others) to the stormwater conveyance system and ultimately to the receiving waters.

Phase I of this project is designed to improve water quality by implementing Best Management Practices (BMPs) and phase II would implement water conservation through beneficial use for irrigation. Phase I of the proposed project consists of the construction of a stormwater diversion structure, a primary pump station system, an underground detention reservoir, a secondary pump system, three force mains for flow conveyance, and upgrade of four sanitary sewer segments southwest of the primary pump station (refer to Figure 2).

The proposed project would intercept and divert dry weather flow and portion of the wet weather stormwater flow from the Rose Avenue Storm Drain. Diverted flows would be conveyed to a pump station constructed within Frederick Street right-of-way northwest of the intersection with Rose Avenue. As sewer capacity allows, a portion of the flow, including dry weather flow would be diverted directly to the sanitary sewer via a force main from the proposed pump station to the sanitary sewer and ultimately to the Hyperion Treatment Plant. Portion of the wet weather flows would be diverted via a second force main to an approximately 2.75-million gallon underground reservoir that

would be constructed beneath the Penmar Recreation Center Field 5. Stormwater stored in the reservoir would be held in the reservoir for approximately seventy-two (72) hours after a storm event passes and then discharged at a metered (controlled) rate to the sanitary sewer through a combined gravity and pump system that would be constructed adjacent to the reservoir.

## **Project Elements**

### *Diversion Structure*

The proposed project would construct a passive diversion structure to divert flow from the Rose Avenue Storm Drain within the vicinity of Frederick Street. The Rose Avenue Storm Drain consists of two 9-foot wide by 12-foot high reinforced concrete culvert boxes beneath the street right-of-way. The diversion structure would be designed to carry the required design flow and allow overflow to bypass the diversion structure. It is anticipated that a low concrete berm, approximately 2 feet high, would be constructed in a manner to ensure that it does not impede maintenance of the box culverts. An opening would be created in the interior wall, between the two box culverts, to allow stormwater to flow from one box to the other. The two-foot concrete berm would be angled at 45-degrees to direct the flow toward the openings of the box culvert walls. Two maintenance holes would be needed for access. The design of the connection to the County storm drain would be coordinated with Los Angeles County Department of Public Works. A storm drain transition structure would be constructed to divert stormwater flows to the primary pump station.

### *Primary Pump Station System*

An underground wet well and pump station would be constructed within the Frederick Street right-of-way northwest of the intersection with Rose Avenue to lift stormwater runoff from the Rose Avenue Storm Drain to a detention reservoir beneath the Penmar Recreation Center fields. The wet well and pump station would be approximately 25 feet wide and 180-feet long. The wet well structure would be approximately 25 feet deep. The pump station would have an area designed for trash and debris removal. A bar screen would prevent trash and large debris from the Rose Avenue Storm Drain from entering the wet well area. Two access hatches would be located above this area to allow for maintenance and trash removal. The wet well is anticipated to house four constant speed pumps (five cubic feet per second (cfs) capacity each) and two discharge pumps. The four constant speed pumps would come on in sequence to pump storm flow to the underground detention reservoir. If flow continued to rise at a rate in excess of the pumping capacity, the wet well would reach capacity and excess flow would remain in the storm drain and continue to flow downstream to the current outfall. The temporary flow storage capacity within the wet well is estimated at 70,000 gallons. Maintenance access hatches would be located above the pump area.

### *Underground Detention Reservoir*

The underground detention reservoir would be located beneath Field 5 at the southwestern area of the Penmar Recreation Center. The reservoir is anticipated to be a circular prestressed concrete reservoir approximately 180 feet in diameter and with approximately 2.75 million gallon (MG) storage capacity. The side wall depth is estimated at 17 feet. A 30-inch force main would convey flows from the primary pumping station at Frederick Street to the underground reservoir. A swing check valve on the 30-inch force main with a 12-inch tee fitting would allow a single inlet/outlet structure. A 12-inch connection would serve as a connection point to an adjacent secondary pump station system that would convey flows to a sanitary sewer line in Rose Avenue.

An inspection and maintenance access hatch and two air vents would be included in the reservoir design and sited in areas that would not interfere with the use of the field.

The reservoir design would also include an emergency overflow spillway, which would be connected to the Rose Avenue Storm Drain. The spillway would begin to receive overflow if the reservoir exceeded 16-foot depth and water began to encroach into a one-foot freeboard that would be included in the design capacity. The spillway would only come into service if the “reservoir full – pump shut off” sensor ever failed and the Primary Pumping Station on Frederick Street in turn did not shut off.

### *Secondary Pump Station System*

An underground vault housing two pumps would be installed adjacent to reservoir. As indicated above, these pumps would convey flows from the underground detention reservoir to the sanitary sewer line in Rose Avenue. The pumps are currently estimated to have one cfs capacity each. These pumps are necessary to allow for removal of stormwater from the reservoir and “lifting” to a higher elevation for discharge into the sanitary sewer line. This pump station vault would likely consist of a pre-cast maintenance hole structure, approximately 10 feet in diameter.

### *Electrical Control Panel Boxes*

A lockable electrical control panel box would be installed above ground in the shoulder of the Frederick Street right-of-way, adjacent to the Penmar Golf Course. The box would be a stainless steel enclosure, approximately four feet wide, two feet deep, and seven feet tall. It would house the electrical switchgear to activate the pumps within the Frederick Street Pump Station. Telemetry would also be located in this box to signal stormwater elevations and pump status to a remote facility which is staffed continuously.

A similar electrical control panel box would be installed above ground adjacent to the underground secondary pump station system by the Penmar Recreation Center Field 5.

### *Minor Sanitary Sewer Upgrades*

The project also includes upgrading approximately 650 feet of trunk sanitary sewer west of the Rose Avenue Storm Drain Diversion. The upgrade would alleviate hydraulic constraints in the system to provide capacity on four segments of sewer pipe. Three of the four segments would be replaced with 21-inch diameter vitrified clay pipe (VCP) as follows: 250 feet of 16-inch pipe on Oakwood Avenue between Millwood Avenue and Rialto Court; 145 feet of 16-inch pipe on Rialto Court south of Nowita Place and 75 feet of 18-inch pipe on Abbot Kinney Boulevard at the intersection with Palms Boulevard. The fourth segment, 180 feet of 16-inch pipe on Crescent Place (pedestrian walk) between Rialto Court and Palms Boulevard, would be replaced with 21-inch high density polyethylene (HDPE) pipe using pipe reaming construction.

### *Penmar Recreation Center Field 5 Restoration*

Excavated areas would be backfilled and ground cover installed after construction of the underground detention reservoir. Field 5 would be restored and the affected irrigation system would be replaced with an upgraded “smart irrigation system” that senses atmospheric conditions to prevent over-watering. Proposed landscape improvements are and would continue to be coordinated with the Department of Recreation and Parks. No tree removals are anticipated.

### *Phase II – Stormwater Beneficial Use for Irrigation*

A disinfection system would be built within the vicinity of the underground detention reservoir to treat a portion of the stormwater flow. The treated water would be locally used for landscape irrigation at one or more of the following facilities: Penmar Golf Course, Penmar Recreation Center, and/or Marine Park. The specific treatment design and methodology would be selected during the pre-design and design stages for that phase. Disinfection would be accomplished through chlorine, ozone, or ultraviolet treatment to meet applicable RWQCB-LA and/or the Los Angeles County Public Health requirements. Depending on the disinfection methodology or technology used for bacteria treatment, additional CEQA review would be conducted prior to phase II final design.

## **Preliminary Construction Schedule**

It is currently anticipated that Phase I construction would begin fall 2009 and Phase II construction is anticipated to begin summer 2011.

## **Operation and Maintenance**

Operation and maintenance (O & M) would be the responsibility of the Department of Public Works Bureau of Sanitation (BOS) and Department of Recreation and Parks (RAP). The BOS would be responsible for the O & M of the BMP elements and it is anticipated that RAP would continue to maintain the park, including the landscape and

the irrigation system after the improvements have been completed.

An Operations and Maintenance (O & M) program would be prepared for the Best Management Practices (BMP) and the landscape and irrigation as a part of the detailed construction phase. The program is anticipated to include maintenance recommendations provided by the manufacturers to ensure that the structural BMPs perform optimally. The proposed improvements would not change the existing use of the park or increase the park's overall size. O & M procedures would be performed in accordance with a Master Agreement between the Bureau of Engineering and BOS (Department of Public Works) and RAP for the construction and maintenance of Proposition O projects, as supplemented by the project-specific Memorandum of Understanding for this project.

Anticipated O & M activities would include, but not be limited to the following:

- Inspection and periodic trash removal from the pump station.
- Inspection and sediment removal from the tank and other system elements as applicable.
- Inspection and maintenance of the stormwater disinfection system.
- Water quality monitoring. Analytical results would help determine if modifications to the treatment systems or maintenance program were needed.

### **Project Actions and Approvals**

The proposed project and environmental documentation, including this Initial Study/Mitigated Negative Declaration, would require approval by the City of Los Angeles Board of Public Works and City Council. Additional anticipated approvals or permits for the proposed project include, but are not limited to the following:

- State of California Coastal Commission, Coastal Development Permit
- State Water Resources Control Board/ RWQCB-LA, project review and NPDES General Construction Permit
- Los Angeles County Department of Public Works Flood Control District, permit for modification to storm drain system (under County jurisdiction)
- City of Los Angeles Department of Building and Safety, building and grading permits
- City of Los Angeles Department of Public Works, Bureau of Engineering, Local Coastal Development Permit
- City of Los Angeles Department of Transportation, Traffic Control Plan review
- City of Los Angeles Department of Recreation and Parks, project and design review

The analysis in this document assumes that, unless otherwise stated, the project will be designed, constructed and operated following all applicable laws, regulations, ordinances and formally adopted City standards (e.g., *Los Angeles Municipal Code* and Bureau of Engineering *Standard Plans*). Construction will follow the uniform practices

*INITIAL STUDY  
PUBLIC WORKS – BUREAU OF ENGINEERING*

established by the Southern California Chapter of the American Public Works Association (e.g., *Standard Specifications for Public Works Construction* and the *Work Area Traffic Control Handbook*) as specifically adapted by the City of Los Angeles (e.g., The City of Los Angeles Department of Public Works Additions and Amendments to the Standard Specifications For Public Works Construction [AKA "The Brown Book," formerly Standard Plan S-610]).

### III. EXISTING ENVIRONMENT

The proposed project is located within the Penmar Recreation Center and vicinity. The Penmar Recreation Center is a multi-use park located approximately twelve miles west of downtown Los Angeles at 1341 Lake Street in the Venice community. The facility is operated and maintained by the City of Los Angeles Department of Recreation and Parks (RAP). It offers seasonal sports, dance classes, cooking classes, and day camps. Existing facility features include an auditorium/gymnasium, picnic areas, tennis courts, handball courts, five (5) baseball diamonds (with associated multi-purpose fields), and lighted outdoor and indoor basketball courts. Permitted users for Field 5 include Pacific Coast Soccer Club, Venice Bulldog Pop Warner Football, Planet Social Sports, Santa Monica Rugby, and various groups from RAP Municipal Sports (Guzman 2009).

The Penmar Recreation Center and Golf Course are located within the Venice Community Plan area of the City of Los Angeles. Dewey Street marks the approximate boundary between the City of Los Angeles and the City of Santa Monica. Penmar Recreation Center is zoned for single family residential uses within a very limited height district (R1-IVLD) and the Penmar Golf Course is zoned for open space uses within a limited height district (OS-IXL)<sup>1</sup>. Both sites are designated for open space uses in the City's General Plan. Marine Park is located in the City of Santa Monica's designated parks (DP) zone and is designated for park uses<sup>2</sup>. Land uses within the proposed project site and vicinity consist primarily of open space (park and golf course areas), street right-of-way, single and multiple family residential, commercial, public facilities (schools), and airport uses (Santa Monica Municipal Airport).

Penmar Recreation Center is bounded on the northwest by Rose Avenue, Glenavon Avenue on the northeast, Penmar Avenue on the northwest, and Lake Street on the southwest. Penmar Golf Course is located on the opposite side of Rose Avenue across Penmar Recreation Center. Table 1 lists the major streets within the vicinity of the project area. Several freeways provide regional access to the project site. The Santa Monica Freeway (Interstate I-10) is approximately 1.3 miles to the north of the project site, the Santa Monica Freeway (Interstate I-405) is located approximately 2.0 miles to the east, and the Marina Expressway (SR-90) is located approximately 1.9 miles southeast from the project site.

---

1 Source: City of Los Angeles, DCP, Zone Information & Map Access System (ZIMAS) at <http://zimas.lacity.org/>

2 Source: City of Santa Monica Online Property Information System (OPIS) at [http://www01.smgov.net/isd/gis/interactive\\_maps/index.html](http://www01.smgov.net/isd/gis/interactive_maps/index.html)

**Table 1: Streets within the Vicinity of the Project Site**

Street Name	Classification	Description	Average Daily Traffic (ADT) vehicles/day
Lincoln Blvd. bet Lake St. & Indiana Ct.	Major Highway	100 ft. ROW, 2 traffic lanes and one parking lane in each direction	53,246
Rose Ave. bet Lincoln Blvd. & Frederick St.	Secondary Highway	80 ft. or 83 ft. ROW; one traffic lane, bike lane, and parking lane in each direction plus a median lane and turn lane	11,045
Rose Ave. bet Penmar Ave. & Glenavon Ave.	Secondary Highway	80 ft. ROW; one traffic lane, bike lane, and parking lane in each direction plus a median lane and turn lane	11,720
Rose Ave. bet Walgrove Ave. & Morningside Ave.	Collector	84 ft. ROW, one lane in each direction	8,616
Penmar Ave bet Rose Ave & Lake St.	Collector	80 ft. ROW, one lane in each direction	3,842
Sunset Ave. bet Rose Ave & Flower St.	Local	60 ft. ROW, one lane in each direction at intersection only	1,187
Lake St. bet Penmar Ave. & Courtland St.	Local	50 ft. ROW, one lane in each direction	4,058
Courtland St. bet Rose Ave. & Indiana Ave.	Local	60 ft. ROW, no lane striping	642
Oakwood Ave. bet Palms Blvd. & Rialto Ct.	Local	50 ft. ROW, no lane striping	2,802
Rialto Ct. bet Shell Ave. & Crescent Ct.	Alley	15 ft. ROW	39
Crescent Pl.	"Paper" street	15 ft. ROW, no vehicular traffic, pedestrian walk	0
Palms Blvd. bet Electric Ct. & Shell Ave.	Collector	50 ft. ROW, no lane striping	1,669
Abbot Kinney Blvd. bet Palms Blvd. & Rialto Ct.	Secondary Highway	70 ft. ROW; one traffic lane and parking lane in each direction, plus median and turn lane	21,902

Source: *City of Los Angeles Penmar Water Quality and Runoff Reuse Project Negative Declaration Traffic Study* (FPL and Associates, Inc. 2009), Appendix A

The project site lies within the USGS Beverly Hills and Venice Topographic Quadrangles, and as indicated above, within the Santa Monica Bay Watershed. The Santa Monica Bay Watershed encompasses an area of approximately 414 square miles of land. It extends from the crest of the Santa Monica Mountains on the north to the Ventura-Los Angeles County line on the west to downtown Los Angeles on the southeast. From there, it extends south and west across the Los Angeles plain to include the area east of Ballona Creek and north of the Baldwin Hills (City of Los Angeles 2004). The proposed project targets a drainage area of approximately 1,468 acres that currently drains into the Rose Avenue Storm Drain (Figure 4) and ultimately to the Santa Monica Bay at an outlet at the end of Rose Avenue at Venice Beach.

The project site is located outside of the 100-year flood plain (per FEMA Community Panels No. 060137 0077 C and 060137 0083 D, dated February 4, 1987 and December 2, 1980).

The project site is located in a relatively flat, low-lying area that drains gently to the southwest. Ground surface elevations range from approximately 25 feet above mean sea level (MSL) along the southern limits of the project site to approximately 35 feet above MSL at the northeast corner of the Penmar Golf Course. Regional maps indicate the site is underlain by younger alluvial sediments consisting of unconsolidated gravel,



*INITIAL STUDY  
PUBLIC WORKS – BUREAU OF ENGINEERING*

sand, and silty clay with interbeds of gravelly and sandy stream deposits. A terrace of marine deposits consisting of sand, pebbly sand gravel and silt is identified just north of the project site. The southwesterly portions of the site are located in an area mapped as potentially susceptible to liquefaction during a strong earthquake event. No active or potentially active faults are mapped onsite and no landslides are known to exist on the site. Groundwater beneath the site is anticipated to be encountered at depths ranging from approximately 15 to 29 feet, but could be as shallow as ten (10) feet deep. Refer to Appendix B, *Geotechnical Evaluation Penmar Water Quality Improvement Project, Los Angeles California* (Ninyo & Moore 2008).

The project site and vicinity are located within a highly developed area of the City. The Penmar Recreation Center fields and Penmar Golf course contain landscaped lawn or turf areas and ornamental trees which are regularly trimmed and maintained.

The California Department of Fish and Game Natural Diversity Database identified six sensitive plant species and eight sensitive animal species within the Beverly Hills and Venice Quadrangles. (Refer to Appendix C for the database search report.) However, based on the highly developed nature of the project area and the habitat needs of the listed species, the project site is not considered suitable habitat for any of the listed species.

#### IV. ENVIRONMENTAL EFFECTS/INITIAL STUDY CHECKLIST

This section documents the screening process used to identify and focus upon environmental impacts that could result from this project. The Initial Study Checklist below follows closely the form prepared by the Governor's Office of Planning and Research and was used in conjunction with the City's *CEQA Thresholds Guide* and other sources to screen and focus upon potential environmental impacts resulting from this project. Impacts are separated into the following categories:

- No Impact. This category applies when a project would not create an impact in the specific environmental issue area. A "No Impact" finding does not require an explanation when the finding is adequately supported by the cited information sources (e.g., exposure to a tsunami is clearly not a risk for projects not near the coast). A finding of "No Impact" is explained where the finding is based on project-specific factors as well as general standards (e.g., the project will not expose sensitive receptors to pollutants, based on a project-specific screening analysis).
- Less Than Significant Impact. This category is identified when the project would result in impacts below the threshold of significance, and would therefore be less than significant impacts.
- Less Than Significant After Mitigation. This category applies where the incorporation of mitigation measures would reduce a "Potentially Significant Impact" to a "Less Than Significant Impact." The mitigation measures are described briefly along with a brief explanation of how they would reduce the effect to a less than significant level. Mitigation measures from earlier analyses may be incorporated by reference.
- Potentially Significant Impact. This category is applicable if there is substantial evidence that a significant adverse effect might occur, and no feasible mitigation measures could be identified to reduce impacts to a less than significant level. If there are one or more "Potentially Significant Impact" entries when the determination is made, an Environmental Impact Report (EIR) is required. There are no such impacts for the proposed project.

Sources of information that adequately support these findings are referenced following each question. All sources so referenced are available for review at the offices of the Bureau of Engineering, 1149 South Broadway, Suite 600, Los Angeles, California 90015. Please call Maria Martin at (213) 485-5753 for an appointment.

<h1>Issues</h1>	Potentially Significant Impact	Less Than Significant With	Less Than Significant	No Impact
-----------------	--------------------------------	----------------------------	-----------------------	-----------

**1. AESTHETICS** – Would the project:

- a) Have a substantial adverse effect on a scenic vista?

Reference: *L.A. CEQA Thresholds Guide* (Sections A.1 and A.2), and *Venice Community Plan*  
 Comment: A scenic vista generally provides focal views of objects, settings, or features of visual interest; or panoramic views of large geographic areas of scenic quality, primarily from a given vantage point. A significant impact may occur if the proposed project introduced incompatible visual elements within a field of view containing a scenic vista or substantially altered a view of a scenic vista.

Both the Penmar Recreation Center and Golf Course are located within an urban setting and are surrounded by fencing. No scenic vistas are located within the vicinity of the proposed project. Most of the proposed project elements would be located below ground. Two electrical control panel boxes would be installed above ground adjacent to the Frederick Street right-of-way and adjacent to Penmar Recreation Center filed 5.

- b) Substantially damage scenic resources, including, but not limited to, trees, rock outcroppings, and historic buildings within a state scenic highway?

Reference: California Scenic Highway Mapping System, *L.A. CEQA Thresholds Guide* (Sections A.1 and A.2) and *Venice Community Plan*  
 Comment: A significant impact may occur where scenic resources within a state scenic highway would be damaged or removed as a result of the proposed project.

No scenic state highways are located within the project site or vicinity.

- c) Substantially degrade the existing visual character or quality of the site and its surroundings?

Reference: *L.A. CEQA Thresholds Guide* (Sections A.1 and A.2)  
 Comment: A significant impact may occur if the proposed project introduced incompatible visual elements to the project site or visual elements that would be incompatible with the character of the area surrounding the project site.

See comment for 1 (a) above.

- d) Create a new source of substantial light or glare that would adversely affect day or nighttime views in the area?

Reference: *L.A. CEQA Thresholds Guide* (Section A.4)  
 Comment: A significant impact would occur if the proposed project caused a substantial increase in ambient illumination levels beyond the property line or caused new lighting to spill-over onto light-sensitive land uses such as residential, some commercial and institutional uses that require minimum illumination for proper function, and natural areas.

No new sources of light or glare would be built. Construction lighting would be used as necessary on a temporary basis and would be governed by Municipal Code and Standard Specifications designed to minimize impacts (e.g. it would be shielded and directed toward the construction, away from residences).

<b>Issues</b>	Potentially Significant Impact	Less Than Significant With	Less Than Significant	No Impact
---------------	--------------------------------	----------------------------	-----------------------	-----------

**2. AGRICULTURE RESOURCES** – Would the project:

- a) Convert Prime Farmland, Unique Farmland, or Farmland of Statewide Importance (Farmland), as shown on the maps prepared pursuant to the Farmland Mapping and Monitoring Program of the California Resources Agency, to non-agricultural use?

Reference: CDC - Div. of Land Resource Protection, City of Los Angeles General Plan Conservation Element, Zone Information & Map Access System (ZIMAS)

Comment: A significant impact may occur if the proposed project were to result in the conversion of state-designated agricultural land from agricultural use to a non-agricultural use.

No prime or unique farmland, or farmland of statewide importance, exists within the City of Los Angeles. The project site is not located on or near any property zoned or otherwise intended for agricultural uses.

- b) Conflict with existing zoning for agricultural use, or a Williamson Act contract?

Reference: CDC - Div. of Land Resource Protection, *City of Los Angeles General Plan Conservation Element*, Zone Information & Map Access System (ZIMAS)

Comment: A significant impact may occur if the proposed project were to result in the conversion of land zoned for agricultural use, or indicated under a Williamson Act contract, from agricultural use to a non-agricultural use.

No land on or near the project site is zoned for or contains agricultural uses. The City of Los Angeles does not participate in the Williamson Act. Therefore, there are no Williamson Act properties in the City of Los Angeles.

- c) Involve other changes in the existing environment which, due to their location or nature, could result in conversion of farmland, to non-agricultural use?

Reference: CDC - Div. of Land Resource Protection, , City of Los Angeles General Plan Conservation Element, Zone Information & Map Access System (ZIMAS)

Comment: A significant impact may occur if a project results in the conversion of farmland to another non-agricultural use.

See Comments for 2 (a) and 2 (b) above.

**3. AIR QUALITY** – Would the project:

- a) Conflict with or obstruct implementation of the applicable air quality plan?

Reference: *L.A. CEQA Thresholds Guide* (Sections B1 and B2 ) and *Venice Community Plan*

Comment: The proposed project is located within the South Coast Air Basin which is under the jurisdiction South Coast Air Quality Management District (SCAQMD). The SCAQMD is the air pollution control district responsible for the Air Quality Management Plan (AQMP), which is a comprehensive air pollution control program for attaining state and federal ambient air quality standards. As part of its General Plan, the City adopted an Air Quality Element that contains policies and goals for attaining state and federal air quality standards, while simultaneously facilitating local economic growth and includes implementation strategies for local programs contained in the AQMP. A significant impact would occur if the project were not consistent with the AQMP or the City's General Plan.

The *Venice Community Plan* recognizes the need to ensure the availability of adequate public

<h1>Issues</h1>	Potentially Significant Impact	Less Than Significant With	Less Than Significant	No Impact
-----------------	--------------------------------	----------------------------	-----------------------	-----------

facilities. The proposed project would serve existing and intended land uses and would not include regional employment or population growth. The main objectives of the project are to meet regulatory requirements and improve water quality. Existing uses would not be changed. The project would also not result in a violation of air quality standards, as discussed in item 3(b) below. The project would therefore be consistent with the AQMP.

- b) Violate any air quality standard or contribute substantially to an existing or projected air quality violation?

Reference: *L.A. CEQA Thresholds Guide* (Sections B1 and B2 )

Comment: A significant impact may occur if the proposed project violated any SCAQMD air quality standard. The SCAQMD has set thresholds of significance for reactive organic gases (ROG), nitrogen oxides (NOx), carbon monoxide (CO), sulfur dioxide (SO<sub>2</sub>), and particulate matter (PM10) emissions resulting from construction and operation in the South Coast Air Basin. SCAQMD has also set interim CEQA greenhouse gas (GHG) thresholds for industrial projects.

Construction emissions have been estimated using the URBEMIS 2007 (Version 9.2.4) computer model recommended by the SCAQMD, see Appendix D for results. As shown below, daily construction emissions would not exceed SCAQMD significance thresholds.

	ROG lbs/day	NOX lbs/day	CO lbs/day	SOX lbs/day	PM10 lbs/day	PM2.5
Construction Peak Daily Emissions	7	84	41	0	76	18
SCAQMD Construction Emission Thresholds	75	100	550	150	150	55

Minimal emissions are anticipated as a result of operation and maintenance. The total emissions from worker vehicle exhaust are considered negligible and should not exceed SCAQMD daily operational emission thresholds or have a significant impact on air quality.

Although construction emission are anticipated to be below SCAQMD thresholds, contractors would be required to follow all applicable SCAQMD rules and regulations, including AQMD Rule 403 (Fugitive Dust) and 431 (Diesel Equipment), to minimize air quality impacts. Contractors, for example, would water dusty areas and minimize the tracking of soil from unpaved dirt areas to paved roads.

SCAQMD has recommended a greenhouse gas significance threshold of 10,000 metric tons per year of carbon dioxide equivalent (CO<sub>2</sub>e) for assessing the significance of potential GHG emissions. SCAQMD allows GHG emissions from construction to be amortized over 30 years. However, the assessment conducted for this project applied the threshold to the estimated total GHG emissions for a conservative assessment. CO<sub>2</sub> construction emissions were estimated at 366 metric tons/project, which is below the recommended threshold.

- c) Result in a cumulatively considerable net increase of any criteria pollutant for which the project region is in non-attainment under an applicable federal or state ambient air quality standard (including releasing emissions that exceed quantitative thresholds for ozone precursors)?

Reference: *L.A. CEQA Thresholds Guide* (Sections B1 and B2 ), 2006 State Area Designation Maps from <http://www.arb.ca.gov/desig/adm/adm.htm#state>

<h1>Issues</h1>	Potentially Significant Impact	Less Than Significant With	Less Than Significant	No Impact
-----------------	--------------------------------	----------------------------	-----------------------	-----------

Comment: A significant impact would occur if the proposed project resulted in a cumulatively considerable net increase of a criteria pollutant for which the South Coast Air Basin exceeds federal and state ambient air quality standards and has been designated as an area of non-attainment by the USEPA and/or California Air Resources Board. The South Coast Air Basin is a non-attainment area for ozone, fine particulate matter (PM10), and carbon monoxide (federal only).

As indicated in item 3(b) above, construction and operational emissions of the project would not exceed the SCAQMD's thresholds of significance for criteria pollutants. For those emissions generated during construction, the minor generation of criteria pollutants would be temporary and short-term in nature.

- d) Expose sensitive receptors to substantial pollutant concentrations?

Reference: *L.A. CEQA Thresholds Guide* (Sections B1, B2, and B3 )

Comment: A significant impact would occur if construction or operation of the proposed project generated pollutant concentrations to a degree that would significantly affect sensitive receptors.

As discussed above, the proposed project is not anticipated to result in substantial pollutant concentrations.

- e) Create objectionable odors affecting a substantial number of people?

Reference: *L.A. CEQA Thresholds Guide* (Sections B1 and B2 )

Comment: A significant impact would occur if the project created objectionable odors during construction or operation that would affect a substantial number of people.

During construction, sources of odor are diesel emissions from construction equipment and volatile organic compounds from sealant applications or paving activities. However, these odors would be temporary and localized. Nonetheless, applicable best management practices such as those in SCAQMD Rule 431 (Diesel Equipment) would, in addition to minimizing air quality impacts, also help minimize potential construction odors.

Air emissions, including odors, during operation are anticipated to be absent or minimal. Project elements such as the detention reservoir and stormwater diversion structure are passive. The active components are the pump station systems that convey water through the force mains. The pump stations operate solely on electricity. Therefore, air emissions would not be produced. The only potential source of air emissions or odors would be the vent on the tank that is part of the reservoir system. There is a small potential for buildup of organic matter carried in the stormwater in the tank. Under anaerobic conditions, odors and methane could be released and could pose an impact. However, the facility is designed with a sump and a bar screen to capture most of the organic matter being carried by the stormwater before entering the tank. In addition, the interior of the tank would be designed to be equalized with the atmosphere, therefore anaerobic conditions should not form. Additionally, regular inspection and cleaning should further reduce the potential for buildup of material that could release odors.

**4. BIOLOGICAL RESOURCES** – Would the project:

Issues	Potentially Significant Impact	Less Than Significant With	Less Than Significant	No Impact
<p>a) Have a substantial adverse effect, either directly or through habitat modifications, on any species identified as a candidate, sensitive, or special status species in local or regional plans, policies, or regulations, or by the California Department of Fish and Game or U.S. Fish and Wildlife Service?</p> <p>Reference: CNDDDB, City of Los Angeles General Plan, City of Los Angeles General Plan Conservation Element, L.A. CEQA Thresholds Guide (Section C), U.S. Fish and Wildlife Service Habitat Conservation Plan (HCP) Program, U.S. Fish and Wildlife Service Critical Habitat Database (<a href="http://crithab.fws.gov/">http://crithab.fws.gov/</a>)</p> <p>Comment: A significant impact may occur if the proposed project would remove or modify habitat for any species identified or designated as a candidate, sensitive, or special status species in local or regional plans, policies, or regulation, or by the state or federal regulatory agencies cited.</p> <p>The BMP elements and sewer upgrades, which constitute the major construction elements of the proposed project will occur within hardscape areas within the public right-of-way and beneath the Penmar Recreation Center Field 5. The site is heavily used and devoid of potential habitat for sensitive species. The lawn or turf grass on Field 5 would be removed and replace after installation of the detention tank. No removal of adjacent trees or other vegetation is anticipated.</p> <p>The CNDD lists occurrences of the following plant and animal species which are federally and/or state listed as endangered or threatened plant species within the USGS Beverly Hills and Venice Quadrangles. However, none of the occurrences were listed for Penmar Recreation Center park or vicinity. See Appendix C for database search results.</p> <p>Plants – Braunton’s milk-vetch, Ventura Marsh milk-vetch, coastal dunes milk-vetch, San Fernando Valley spineflower, salt marsh bird’s-beak, and beach spectaclepod. Due to the highly urbanized nature and high intensity of use of the site in addition to species habitat requirements, these species are not anticipated to occur within the project site.</p> <p>Animals - western snowy plover, El Segundo blue butterfly, California black rail, Belding’s savannah sparrow, California brown pelican, Pacific pocket mouse, coastal California gnatcatcher, California least tern. Due to the highly urbanized nature and high intensity of use of the site in addition to species habitat requirements, these species are not anticipated to occur within the project site.</p>	<input type="checkbox"/>	<input type="checkbox"/>	<input checked="" type="checkbox"/>	<input type="checkbox"/>
<p>b) Have a substantial adverse effect on any riparian habitat or other sensitive natural community identified in local or regional plans, policies, regulations or by the California Department of Fish and Game or US Fish and Wildlife Service?</p> <p>Reference: CNDDDB, City of Los Angeles General Plan Conservation Element, L.A. CEQA Thresholds Guide (Section C), U.S. Fish and Wildlife Service Habitat Conservation Plan (HCP) Program, U.S. Fish and Wildlife Service Critical Habitat Database (<a href="http://crithab.fws.gov/">http://crithab.fws.gov/</a>)</p> <p>Comment: A significant impact may occur if riparian habitat or any other sensitive natural community were to be adversely modified. See comment for 4 (a).</p>	<input type="checkbox"/>	<input type="checkbox"/>	<input type="checkbox"/>	<input checked="" type="checkbox"/>
<p>c) Have a substantial adverse effect on federally protected wetlands as</p>	<input type="checkbox"/>	<input type="checkbox"/>	<input type="checkbox"/>	<input checked="" type="checkbox"/>

<h1>Issues</h1>	Potentially Significant Impact	Less Than Significant With	Less Than Significant	No Impact
-----------------	--------------------------------	----------------------------	-----------------------	-----------

defined by Section 404 of the Clean Water Act (including, but not limited to, marsh, vernal pool, coastal, etc.) through direct removal, filling, hydrological interruption, or other means?

Reference: CNDDDB, *City of Los Angeles General Plan Conservation Element, L.A. CEQA Thresholds Guide* (Section C), U.S. Fish and Wildlife Service Habitat Conservation Plan (HCP) Program, U.S. Fish and Wildlife Service Critical Habitat Database (<http://crithab.fws.gov/>)

Comment: A significant impact may occur if federally protected wetlands, as defined by Section 404 of the Clean Water Act, would be modified or removed.

No wetlands are located within the project site.

- d) Interfere substantially with the movement of any native resident or migratory fish or wildlife species or with established native resident or migratory wildlife corridors, or impede the use of native wildlife nursery sites?

Reference: *L.A. CEQA Thresholds Guide* (Section C)

Comment: A significant impact may occur if the proposed project interfered or removed access to a migratory wildlife corridor or impeded the use of native wildlife nursery sites.

The project area is highly urbanized and heavily used and does not provide significant habitat for wildlife. No tree removals are anticipated. The turf or lawn to be removed is within a field used for various sports. The project is not expected to have an impact on habitat suitable for wildlife movement or migration.

- e) Conflict with any local policies or ordinances protecting biological resources, such as a tree preservation policy or ordinance?

Reference: *L.A. CEQA Thresholds Guide* (Section C)

Comment: A significant impact may occur if the proposed project would cause an impact that was inconsistent with local regulations pertaining to biological resources.

No impact to sensitive or protected tree species is anticipated. Other than removal and replacement of lawn or turf grass, no other vegetation removal is anticipated.

- f) Conflict with the provisions of an adopted Habitat Conservation Plan, Natural Community Conservation Plan, or other approved local, regional, or state habitat conservation plan?

Reference: CNDDDB, *City of Los Angeles General Plan, City of Los Angeles General Plan Conservation Element, L.A. CEQA Thresholds Guide* (Section C), U.S. Fish and Wildlife Service Habitat Conservation Plan (HCP) Program

Comment: A significant impact may occur if the proposed project would be inconsistent with the provisions of the adopted habitat conservation plans of the cited type.  
See comments for 4 (a) through (e).

**5. CULTURAL RESOURCES** – Would the project:

- a) Cause a substantial adverse change in the significance of a historical resource as defined in California Code of Regulations Section 15064.5?

Reference: *Cultural Resources Survey Report Penmar Water Quality Improvement and Runoff Reuse Project; L.A. CEQA Thresholds Guide* (Section D.3), City of Los Angeles Cultural Heritage Commission "Historic-Cultural Monuments (HCM) Report by Planning Community", *Venice Community Plan*



<h1>Issues</h1>	Potentially Significant Impact	Less Than Significant With	Less Than Significant	No Impact
-----------------	--------------------------------	----------------------------	-----------------------	-----------

Comment: A significant impact may result if the proposed project caused a substantial adverse change to the significance of a historical resource (as identified above).

No historic resources were identified within the project area. The project passes through a residential area of late-historic period of local residential development (early 1900's to the latter half of the 20<sup>th</sup> Century): a mix of Ranch Style architecture (circa 1935-1960), California Ranch Bungalow style architecture, Colonial Revival, Craftsman Bungalow, Minimal Traditional and early Ranch transitional forms, Modern, National Folk, and Hipped Vernacular types (ArchaeoPaleo Resource Management Inc. 2009). However, with the exception of one dwelling adjacent to Rialto Court (discussed below), the other buildings and their settings are outside of the project's area of potential effect and are not anticipated to be adversely affected by the proposed project.

At Crescent Place between Rialto Court and Palms Boulevard, the project proposes to use pipe reaming construction method. The sewer line lies within City property beneath an area currently used as a yard for one of the adjacent dwellings. However, with the use of pipe reaming construction method, no significant impacts to the adjacent property are anticipated.

The cultural resource survey conducted for the proposed project indicates potential for recovery of cultural (archeological) resource materials. See discussion under 5 (b) below for additional information.

- b) Cause a substantial adverse change in the significance of an archaeological resource pursuant to California Code of Regulations Section 15064.5?

Reference: *Cultural Resources Survey Report Penmar Water Quality Improvement and Runoff Reuse Project, L.A. CEQA Thresholds Guide* (Section D.3), City of Los Angeles Cultural Heritage Commission "Historic-Cultural Monuments (HCM) Report by Planning Community", *Venice Community Plan*

Comment: A significant impact may occur if the proposed project were to cause a substantial adverse change in the significance of an archaeological resource which falls under the CEQA Guidelines section cited above.

The cultural resource survey conducted for the proposed project indicates the project site and vicinity are located in an area sensitive for historic and prehistoric cultural resources. The mitigation measures described below shall be implemented prior to and during construction, as applicable, to mitigate impacts to a less than significant level:

**Mitigation Measure CUL1:** Archaeological monitoring by a qualified archaeological monitor shall be conducted during all ground-disturbing activities in connection with the proposed project until the archeological monitor deems there is a low potential for finding cultural materials. The archaeological monitor responsible for monitoring the Rialto Court/Crescent Place project area shall also be familiar with historic architectural resources. Ground-disturbing activities include, but are not limited to, pavement/asphalt removal, boring, trenching, grading, excavating, and foundation demolition.

**Mitigation Measure CUL2:** Prior to the commencement of construction activities, a Cultural Resources Monitoring and Mitigation Plan (CRMMP) shall be prepared. The CRMMP shall include, but not be limited to, construction monitoring protocol of all ground-disturbing project related construction activities; a construction worker training protocol and program; and

<h1>Issues</h1>	Potentially Significant Impact	Less Than Significant With	Less Than Significant	No Impact
-----------------	--------------------------------	----------------------------	-----------------------	-----------

cultural resource recovery and processing protocol if cultural resources are discovered. As applicable, the archaeological monitor shall follow the plan during construction.

**Mitigation Measure CUL3:** Upon completion of all ground-disturbing activities associated with the project, an Archaeological Resources Monitoring Report shall be prepared, documenting activities carried out under the CRMPP.

- c) Directly or indirectly destroy a unique paleontological resource or site or unique geologic feature?

Reference: *Integrated Resources Management Plan, L.A. CEQA Thresholds Guide* (Section D.1), *Standard Specification for Public Works Construction*

Comment: A significant impact may occur if grading or excavation activities associated with the proposed project would disturb unique paleontological resources or unique geologic features.

According to the Geotechnical evaluation conducted for this project, the materials encountered in the borings generally consisted of fill soils underlain by alluvial deposits to the depths explored of approximately 21 ½ to 51 ½ feet. Below the fill soil, alluvial soils were encountered to the depths explored. According to the report, geologic maps of the area indicate the site is underlain by younger alluvium. The *L.A. CEQA Thresholds Guide* indicates paleontological potential for Quaternary (younger) alluvium is Low to High. The Environmental Impact Report for the *Integrated Resources Management Plan* indicates the project area is located in an area sensitive for paleontological resources. The mitigations measure identified below would be implemented to ensure potential adverse impacts would be reduced to a less than significant level.

**Mitigation Measure CUL4:** Prior to any excavation in undisturbed soils (undisturbed alluvial deposits), a qualified paleontologist shall be retained to develop a monitoring and fossil remains treatment plan for construction-related activities that could disturb potential unique paleontological resources within the project area. The plan shall be implemented during construction and include, but not be limited to, the following:

- Authority for the paleontologist to halt, temporarily divert, or redirect grading in the area of an exposed fossil to facilitate evaluation and, if necessary, salvage.
- Provision for fossil identification and cataloguing before being donated to their final repository.
- Provision for the preparation of a report detailing results of the monitoring and treatment efforts, listing the fossils collected, and naming the repository.

- d) Disturb any human remains, including those interred outside of formal cemeteries?

Reference: *Standard Specification for Public Works Construction, L.A. CEQA Thresholds Guide* (Section D.2)

Comment: A significant impact may occur if grading or excavation activities associated with the proposed project would disturb interred human remains.

No known burial sites are located within the project site. Should human remains be encountered during construction, per standard public works construction practice, work would be temporarily diverted from the vicinity of the find until the coroner is notified in accordance with the Health and Safety Code Section 7050.5. If the remains were determined to be of Native American descent, the coroner would have 24 hours to notify the Native American

<h1>Issues</h1>	Potentially Significant Impact	Less Than Significant With	Less Than Significant	No Impact
-----------------	--------------------------------	----------------------------	-----------------------	-----------

Heritage Commission (NAHC). The NAHC would identify the person(s) thought to be the Most Likely Descendent, who would then help determine the appropriate course of action.

**6. GEOLOGY AND SOILS** – Would the project:

a) Expose people or structures to potential substantial adverse effects, including the risk of loss, injury, or death involving:

i) Rupture of a known earthquake fault, as delineated on the most recent Alquist-Priolo Earthquake Fault Zoning Map issued by the State Geologist for the area or based on other substantial evidence of a known fault?

Reference: CDC Publication 42; *Geotechnical Evaluation Penmar Water Quality Improvement Project, Los Angeles, California*; L.A. CEQA Thresholds Guide (Section E.1), *General Plan Safety Element*

Comment: A significant impact may occur if the proposed project were located within a state-designated Alquist-Priolo Zone or other designated fault zone and appropriate building practices were not followed.

The project site is not located within a State of California Earthquake Fault Zone (formerly known as an Alquist-Priolo Special Study Zone). As is most of southern California, the site is located in a seismically active area. However, no active faults are known to cross the project site. The closest active fault is the Santa Monica fault which is located 2.2 miles northeast of the project site (Ninyo & Moore 2008). The design peak ground acceleration for this project was estimated to be 0.45g (Ninyo & Moore 2008). Applicable building code requirements would be implemented. As part of building code (applicable California Building Code Seismic Design Criteria) and BOE Standard Project Specifications, construction measures are prescribed that enable safe and efficient project implementation within areas subject to seismic movement. Per standard practice, site-specific geotechnical and geological investigations that focus on these potential hazards are performed as part of project design studies and applicable recommendations incorporated.

ii) Strong seismic ground shaking?

Reference: *Geotechnical Evaluation Penmar Water Quality Improvement Project, Los Angeles, California*; L.A. CEQA Thresholds Guide (Section E.1); Planning Department “Parcel Profile Report”

Comment: A significant impact may occur if the proposed project design did not comply with building code requirements intended to protect people from hazards associated with strong seismic ground shaking.

See comment 6(a)(i).

iii) Seismic-related ground failure, including liquefaction?

Reference: CDC Publication 42; *Geotechnical Evaluation Penmar Water Quality Improvement Project, Los Angeles, California*; L.A. CEQA Thresholds Guide (Section E.1), *General Plan Safety Element*

Comment: A significant impact may occur if the proposed project would be located in an area identified as having a high risk of liquefaction and appropriate design measures required within such designated areas were not incorporated into the project.

The southwest approximate half of the site is located in an area mapped as potentially liquefiable (Ninyo & Moore 2008). An analysis of the earthquake-induced liquefaction

<b>Issues</b>	Potentially Significant Impact	Less Than Significant With	Less Than Significant	No Impact
---------------	--------------------------------	----------------------------	-----------------------	-----------

potential at the site was performed. The results of the investigation indicate the soils between approximate depths of 35 and 40 feet below the surface are susceptible to liquefaction. However, the analysis indicates surface manifestation of dynamic settlement should not cause damage to shallow foundations and mat foundations (Ninyo & Moore 2008).

iv) Landslides?

Reference: General Plan (Landslide Inventory and Hillside Areas in the City of Los Angeles Map), *Geotechnical Evaluation Penmar Water Quality Improvement Project, Los Angeles, California*; Planning Department "Parcel Profile Report", *L.A. CEQA Thresholds Guide* (Section E.1);

Comment: No known landslide areas are identified on the project site. Additionally, given the relatively level topography of the site, landslides are not considered to be a potential hazard at the project site.

b) Result in substantial soil erosion or the loss of topsoil?

Reference: *L.A. CEQA Thresholds Guide* (Section E.2), Planning Department "Parcel Profile Report"

Comment: A significant impact may occur if the proposed project were to expose large areas to the erosion effects of wind or water for a prolonged period of time.

The project site is not located in a high wind area. Construction of the proposed project would result in ground surface disruption activities, such as site grading and excavation. These activities could result in the potential for erosion to occur at the proposed project site. However, soil exposure would be temporary and short-term in nature and applicable Department of Building and Safety erosion control techniques would limit potential erosion.

c) Be located on a geologic unit or soil that is unstable, or that would become unstable as a result of the project, and potentially result in on- or off-site landslide, lateral spreading, subsidence, liquefaction or collapse?

Reference: *Geotechnical Evaluation Penmar Water Quality Improvement Project, Los Angeles, California*; *L.A. CEQA Thresholds Guide* (Section C1), General Plan (Landslide Inventory and Hillside Areas in the City of Los Angeles Map), Planning Department "Parcel Profile Report"

Comment: A significant impact may occur if the proposed project were built in an unstable area without proper site preparation or design features to provide adequate foundations for project buildings, thus posing a hazard to life and property.

Per standard practice, a geotechnical evaluation is conducted which would prescribe methods, techniques, and specifications for: site preparation, treatment of undocumented fill and/or alluvial soils, fill placement on sloping ground, fill characteristics, fill placement and compactions, temporary excavations and shoring, permanent slopes, treatment of expansive soils, and treatment of corrosive soils. Design construction of the proposed project would conform to recommendations in the geotechnical evaluation. See comment for 6(a) (iii).

d) Be located on expansive soil, as defined in Table 18-1-B of the Uniform Building Code (1994), creating substantial risks to life or property?

Reference: *Geotechnical Evaluation Penmar Water Quality Improvement Project, Los Angeles, California*; Uniform Building Code

Comment: The geotechnical investigation recommends that the upper 2 feet of soil beneath the

<h1>Issues</h1>	Potentially Significant Impact	Less Than Significant With	Less Than Significant	No Impact
-----------------	--------------------------------	----------------------------	-----------------------	-----------

foundations be comprised of low-expansion potential material that is in accordance with the California Building Code. This measure would reduce adverse effects to the foundations by on-site expansive soils.

- e) Have soils incapable of adequately supporting the use of septic tanks or alternative wastewater disposal systems where sewers are not available for the disposal of wastewater?

Reference:

Comment: A significant impact may occur if the proposed project were built on soils that were incapable of adequately supporting the use of septic tanks or alternative wastewater disposal system, and such a system were proposed.

No septic tanks or alternative wastewater disposal systems are proposed or needed.

**7. HAZARDS AND HAZARDOUS MATERIALS – Would the project:**

- a) Create a significant hazard to the public or the environment through the routine transport, use, or disposal of hazardous materials?

Reference: DTSC's EnviroStor Data Management System

(<http://www.envirostor.dtsc.ca.gov/public>), L.A. CEQA Thresholds Guide (Sections F.1 & F.2), SWRCB LUST and UST listings on Geotracker (<http://geotracker.swrcb.ca.gov>)

Comment: Operation of the proposed facility would not routinely require transport, use, or disposal of significant quantities of hazardous materials, including, but not limited to oils, pesticides, or chemicals. Chlorine, anticipated in solid form, or ozone may be stored and used for disinfection during phase II project implementation. However, these chemicals would be stored in relatively small quantities in appropriate containers and handled per manufacturer's instructions to protect the health and safety of park employees and the public.

Construction activities would be short-term and limited in nature and may involve limited transport, storage, use or disposal of hazardous materials. Some examples of hazardous materials handling include fueling and servicing construction equipment on-site, and the transport of fuels, lubricating fluids, and solvents. These types of materials are not acutely hazardous, and all storage, handling, and disposal of these materials are regulated.

No sites with known hazardous materials releases were identified within the project area or immediate vicinity. The EnviroStor database identified eleven leaking underground fuel tank sites (LUFTs) and one "voluntary clean up site" within one quarter mile of the project site. Nine of the cases were closed. Lincoln Service Station, at 251 Lincoln Boulevard, is an open LUFT site under oversight by the RWQCB-LA. Soil appears to have been impacted at the site by petroleum hydrocarbons. The LUFT site is undergoing assessment. Combined Properties, at 201 Lincoln Avenue is a former dry cleaning site undergoing cleanup under Department of Toxic Substances Control Board (DTSC) oversight. Environmental Assessments have shown a release of tetrachloroethylene impacted soil at the site. Soil vapor extraction is being implemented at the site. Due to the type of media affected and distance from the project site, these two sites are not anticipated to have an impact on the proposed project site. Arco (Former), at 600 Venice Boulevard, is an open LUFT site under oversight by the RWQCB-LA. Groundwater appears to have been impacted at the site by petroleum hydrocarbons. The LUFT site is undergoing remediation. The project site is located upgradient from this site and is not anticipated to be affected by this LUFT.

The LUFT and clean up sites described above are not anticipated to have an impact on the

<h2>Issues</h2>	Potentially Significant Impact	Less Than Significant With	Less Than Significant	No Impact
-----------------	--------------------------------	----------------------------	-----------------------	-----------

proposed project. However, if unknown contamination were identified during project construction or a spill were to occur during construction, agencies with jurisdiction would be notified and immediate measures would be taken to ensure the health and safety of the public and workers and to protect the environment. Any excavation, treatment, and/or disposal of contaminated soils or water would be conducted to the satisfaction of the applicable regulatory agencies, which could include LAFD, LACoFD, LARWQCB and/or DTSC.

- b) Create a significant hazard to the public or the environment through reasonably foreseeable upset and accident conditions involving the release of hazardous materials into the environment?
- Reference: DTSC's EnviroStor Data Management System (<http://www.envirostor.dtsc.ca.gov/public>), *L.A. CEQA Thresholds Guide* (Sections F1 and F.2), SWRCB LUST and UST listings on Geotracker (<http://geotracker.swrcb.ca.gov>)  
Comment: Refer to 7a) above.

- c) Emit hazardous emissions or handle hazardous or acutely hazardous materials, substances, or waste within one-quarter mile of an existing or proposed school?
- Reference: *L.A. CEQA Thresholds Guide* (Section F.2)  
Comment: A significant impact may occur if the proposed project were located within one-quarter mile of an existing or proposed school site and were projected to release toxic emissions which pose a hazard beyond regulatory thresholds.

Four schools and one future school are located within the vicinity of the project site. Walgrove Elementary and Ocean Charter Elementary are located approximately 1,000 feet southeast of the project site and Broadway Elementary and Animo Venice Charter Public High School are located approximately 1,000 feet north of the sewer upgrade sites. First Lutheran School is located approximately 1,200 feet south of the sewer upgrade sites. As discussed in 7a) above, a significant hazard to the public or the environment through the routine transport, use, or disposal of hazardous materials is not anticipated as a result of the proposed project.

- d) Be located on a site which is included on a list of hazardous materials sites compiled pursuant to Government Code Section 65962.5 and, as a result, would it create a significant hazard to the public or the environment?
- Reference: DTSC's EnviroStor Data Management System (<http://www.envirostor.dtsc.ca.gov/public>), *L.A. CEQA Thresholds Guide* (Section F.2), SWRCB's GeoTracker, and USEPA's EnviroMapper  
Comment: The project site is not listed in the State Water Resources Control Board GeoTracker system which includes leaking underground fuel tank sites and Spills, Leaks, Investigations, and Cleanups sites; or the Department of Toxic Substances Control EnviroStor Data Management System which includes CORTESE sites, or the Environmental Protection Agency's database of regulated facilities.

- e) For a project located within an airport land use plan or, where such a plan has not been adopted, within two miles of a public airport or public use airport, would the project result in a safety hazard for people residing or working in the project area?
- Reference: General Plan, *L.A. CEQA Thresholds Guide* (Section F.1), *Venice Community Plan*; *The Thomas Guide*, *Los Angeles County Street Guide* (2007)

<h1>Issues</h1>	Potentially Significant Impact	Less Than Significant With	Less Than Significant	No Impact
-----------------	--------------------------------	----------------------------	-----------------------	-----------

Comment: A significant impact may occur if the proposed project site were located within a public airport land use plan area, or within two miles of a public airport, and would create a safety hazard.

The project site is not located within an airport land use plan. The Santa Monica Municipal Airport is located northeast of Penmar Golf Course. Safety hazards at airports are generally related with aircraft accidents, especially during take off or landing. Airport operation hazards include incompatible land uses, power transmission lines, wildlife hazards, and tall structures that can interfere with aircraft operations. The project consists of BMPs applicable to the City's stormwater infrastructure. Most of the project will be constructed below grade. The site surface would be returned to a condition similar to the pre-project condition. No obstruction to navigable airspace is anticipated.

- f) For a project within the vicinity of a private airstrip, would the project result in a safety hazard for people residing or working in the project area?
- Reference: *L.A. CEQA Thresholds Guide* (Section F.1), *San Pedro Community Plan*; *The Thomas Guide, Los Angeles County Street Guide* (2007)
- Comment: The project site is not located within the vicinity of a private airstrip.

- g) Impair implementation of or physically interfere with an adopted emergency response plan or emergency evacuation plan?
- Reference: *L.A. CEQA Thresholds Guide* (Section F.1)
- Comment: A significant impact may occur if the proposed project were to substantially interfere with roadway operations used in conjunction with an emergency response plan or evacuation plan or would generate sufficient traffic to create traffic congestion that would interfere with the execution of such plan.

The proposed project would not alter the adjacent street system. As applicable, any traffic detour plans during construction would address emergency response or emergency evacuation for implementation during construction.

- h) Expose people or structures to a significant risk of loss, injury or death involving wildland fires, including where wildlands are adjacent to urbanized areas or where residences are intermixed with wildlands?
- Reference: General Plan, including *Venice Community Plan*; Planning Department "Parcel Profile Report"; *NavigateLA*
- Comment: A significant impact may occur if the proposed project were located in a wildland area and poses a significant fire hazard, which could affect persons or structures in the area in the event of a fire.

The project site is not located in or adjacent to a wildland area or in a proposed Very High Fire Hazard Severity Zone.

**8. HYDROLOGY AND WATER QUALITY** – Would the project:

- a) Violate any water quality standards or waste discharge requirements?
- Reference: *L.A. CEQA Thresholds Guide* (Section G.2)
- Comment: A significant impact may occur if the proposed project discharged water which did not meet the quality standards of agencies which regulate surface water quality and water discharge into storm-water drainage systems. For example, if a project were not in compliance

<h1>Issues</h1>	Potentially Significant Impact	Less Than Significant With	Less Than Significant	No Impact
-----------------	--------------------------------	----------------------------	-----------------------	-----------

with all applicable regulations with regard to surface water quality as governed by the State Water Resources Control Board (SWRCB). These regulations include compliance with the Standard Urban Storm Water Mitigation Plan (SUSMP) requirements to reduce potential water quality impacts.

The project's goals include improving water quality during operation. Short-term impacts to water quality due to construction activities would be regulated under California State Water Resources Control Board Water Quality Order No. 99-08-DWQ (General Construction Permit).

Under this permit, the City of Los Angeles would implement a storm water pollution prevention plan and Best Management Construction Practices would be implemented to ensure no significant impacts to water quality occur during construction.

- b) Substantially deplete groundwater supplies or interfere substantially with groundwater recharge such that there would be a net deficit in aquifer volume or a lowering of the local groundwater table level (e.g., the production rate of pre-existing nearby wells would drop to a level which would not support existing land uses or planned uses for which permits have been granted)?

Reference: *L.A. CEQA Thresholds Guide* (Sections G.2 and G.3)

Comment: Groundwater is a major component of the water supply for many public water suppliers in the Los Angeles metropolitan area, and is also used by private industries, as well as a limited number of private agricultural and domestic users. A project would normally have a significant impact on groundwater supplies if it were to result in a demonstrable and sustained reduction of groundwater recharge capacity or change the potable water levels sufficiently that it would reduce the ability of a water utility to use the groundwater basin for public water supplies or storage of imported water, reduce the yields of adjacent wells or well fields, or adversely change the rate or direction of groundwater flow.

The proposed project would not use groundwater resources or alter ground water recharge potential. Changes to the groundwater supply are not anticipated as a result of the proposed project.

- c) Substantially alter the existing drainage pattern of the site or area, including through the alteration of the course of a stream or river, in a manner which would result in substantial erosion or siltation on- or off-site?

Reference: *L.A. CEQA Thresholds Guide* (Sections G.1 and G2)

Comment: A significant impact may occur if the proposed project resulted in a substantial alteration of drainage patterns that resulted in a substantial increase in erosion or siltation during construction or operation of the project.

The proposed project would divert stormwater from a covered box culvert beneath Rose Avenue. Penmar Recreation Center Field 5 would be graded to minimize ponding. Surface drainage patterns would not be significantly altered.

- d) Substantially alter the existing drainage pattern of the site or area, including through the alteration of the course of a stream or river, or substantially increase the rate or amount of surface runoff in a manner that would result in flooding on- or off-site?

Reference: *L.A. CEQA Thresholds Guide* (Section G.1)

Comment: A significant impact may occur if the proposed project resulted in increased runoff



<h1>Issues</h1>	Potentially Significant Impact	Less Than Significant With	Less Than Significant	No Impact
-----------------	--------------------------------	----------------------------	-----------------------	-----------

volumes during construction or operation of the proposed project that would result in flooding conditions affecting the project site or nearby properties.

The volume of stormwater reaching the outlet would be reduced. However, surface runoff volumes would not be significantly altered. Also, see comment for 8 (c) above.

- e) Create or contribute runoff water which would exceed the capacity of existing or planned stormwater drainage systems or provide substantial additional sources of polluted runoff?
- Reference: *L.A. CEQA Thresholds Guide* (Section G.2)

Comment: A significant impact may occur if the volume of runoff were to increase to a level which exceeded the capacity of the storm drain system serving a project site. A significant impact may also occur if the proposed project would substantially increase the probability that polluted runoff would reach the storm drain system.

See comments for 8 (a-d) above.

- f) Otherwise substantially degrade water quality?
- Reference: *L.A. CEQA Thresholds Guide* (Section G.3)
- Comment: A significant impact may occur if a project included potential sources of water pollutants and potential to substantially degrade water quality.

The project's objective is to improve water quality and increase the beneficial and recreational uses of the receiving waters (the Santa Monica Bay) through BMPs within the park and vicinity. Phase II, beneficial reuse, would be designed and implemented in accordance with applicable RWQCB-LA and Los Angeles County Public Health requirements.

- g) Place housing within a 100-year flood hazard area as mapped on a federal Flood Hazard Boundary or Flood Insurance Rate Map or other flood hazard delineation map?
- Reference: FIRM FEMA Panel No 060137 0109 D, *L.A. CEQA Thresholds Guide* (Sections G.1 to G.3)

Comment: No housing is proposed as part of the proposed project.

- h) Place within a 100-year flood hazard area structures that would impede or redirect flood flows?
- Reference: FIRM FEMA Panel No. 060137 0077 C and 060137 0083 D, *L.A. CEQA Thresholds Guide* (Sections G.1 & G.3)

Comment: The project is located outside of the 100-year flood zone.

- i) Expose people or structures to a significant risk of loss, injury or death involving flooding, including flooding as a result of the failure of a levee or dam?
- Reference: *City of Los Angeles General Plan Safety Element, L.A. CEQA Thresholds Guide* (Sections E.1 & G.3)

Comment: A significant impact may occur if the proposed project were located in an area where a dam or levee could fail, exposing people or structures to significant risk of loss, injury or death.

As indicated above, the proposed project site is located outside of the 100-year flood zone. Also, the Inundation and Tsunami Hazard Areas map (Exhibit G) of the Safety Element of the

<h1>Issues</h1>	Potentially Significant Impact	Less Than Significant With	Less Than Significant	No Impact
-----------------	--------------------------------	----------------------------	-----------------------	-----------

*Los Angeles City General Plan* (adopted by City Council November 26, 1996) identifies the project site as being located outside of an inundation area. No impacts related to flooding are anticipated.

- j) Inundation by seiche, tsunami, or mudflow?

Reference: *City of Los Angeles General Plan Safety Element, LA CEQA Thresholds Guide* (Section E.1)

Comment: A significant impact may occur if the proposed project would cause or accelerate geologic hazards, which would result in substantial damage to structures or infrastructure, or expose people to substantial risk of injury.

The Inundation and Tsunami Hazard Areas map (Exhibit G) of the Safety Element of the *Los Angeles City General Plan* (adopted by City Council November 26, 1996) indicates the project site is not located within a potential tsunami hazard area.

**9. LAND USE AND PLANNING** – Would the project:

- a) Physically divide an established community?

Reference: *City of Los Angeles General Plan, LA CEQA Thresholds Guide* (Section H.2)

Comment: Determination of impact is made based on several factors, including whether the proposed project is sufficiently large or otherwise configured in such a way as to create a physical barrier within an established community.

The proposed project involves mostly below ground improvements within an existing City park and adjacent areas and would not adversely impact land uses within the area or act as a physical barrier within the surrounding community.

- b) Conflict with any applicable land use plan, policy, or regulation of an agency with jurisdiction over the project (including, but not limited to the general plan, specific plan, local coastal program, or zoning ordinance) adopted for the purpose of avoiding or mitigating an environmental effect?

Reference: *City of Los Angeles General Plan, LA CEQA Thresholds Guide* (Sections H.1 & H.2)

Comment: A significant impact may occur if the proposed project were inconsistent with the General Plan, or other applicable plan, or with the site's zoning if designated to avoid or mitigate a significant potential environmental impact.

Land uses within the project site consist of open space and public right-of-way within adjacent streets. The proposed project consists of improvements to the stormwater infrastructure system to improve public health and safety. The project would not require changes in land use.

- c) Conflict with any applicable habitat conservation plan or natural community conservation plan?

Reference: *City of Los Angeles General Plan, LA CEQA Thresholds Guide* (Sections H.1 & H.2)

Comment: A significant impact may occur if the proposed project were located within an area governed by a habitat conservation plan or natural community conservation plan and would conflict with such plan.

No habitat conservation plan or natural community conservation plan is known to exist for the project site.

<b>Issues</b>	Potentially Significant Impact	Less Than Significant With	Less Than Significant	No Impact
---------------	--------------------------------	----------------------------	-----------------------	-----------

**10. MINERAL RESOURCES** – Would the project:

- |  |                          |                          |                          |                                     |
|--|--------------------------|--------------------------|--------------------------|-------------------------------------|
| <p>a) Result in the loss of availability of a known mineral resource that would be of value to the region and the residents of the state?<br/>Reference: <i>City of Los Angeles General Plan, L.A. CEQA Thresholds Guide</i> (Section E4)<br/>Comment: No mineral resources are identified within the project area.</p>      | <input type="checkbox"/> | <input type="checkbox"/> | <input type="checkbox"/> | <input checked="" type="checkbox"/> |
| <p>b) Result in the loss of availability of a locally-important mineral resource recovery site delineated on a local general plan, specific plan or other land use plan?<br/>Reference: <i>City of Los Angeles General Plan, L.A. CEQA Thresholds Guide</i> (Sections H.1 &amp; H.2)<br/>Comment: Refer to 10 (a) above.</p> | <input type="checkbox"/> | <input type="checkbox"/> | <input type="checkbox"/> | <input checked="" type="checkbox"/> |

**11. NOISE** – Would the project result in:

- |  |                          |                          |                                     |                          |
|--|--------------------------|--------------------------|-------------------------------------|--------------------------|
| <p>a) Exposure of persons to or generation of noise levels in excess of standards established in the local general plan or noise ordinance, or applicable standards of other agencies?<br/>Reference: <i>City of Los Angeles General Plan, City of Los Angeles Municipal Code, L.A. CEQA Thresholds Guide</i> (Section I), <i>Penmar Water Quality Improvement Project Construction Noise Impact Report</i><br/>Comment: A significant impact may occur if the project resulted in or exposed people to noise levels that exceeded the standards established by the general plan and and/or noise ordinance of the Municipal Code.</p> | <input type="checkbox"/> | <input type="checkbox"/> | <input checked="" type="checkbox"/> | <input type="checkbox"/> |
|--|--------------------------|--------------------------|-------------------------------------|--------------------------|

A baseline noise analysis indicates ambient noise levels within the project area vary ranging from 60.7 dBA\* (within the vicinity of Oakwood Avenue and Palms Boulevard) to 70.6 dBA (within the vicinity of Palms Boulevard and Abbot Kinney Boulevard) (Behrens and Associates, Inc. 2009). Noise levels generated by construction equipment would vary based on several factors, including equipment type and models, operation being performed, and the condition of the equipment (refer to Appendix E for results of a noise impact evaluation). Assuming worst case scenario where all equipment are running simultaneously, construction activities are anticipated to generate noise levels ranging from 84 to 92 dBA. Construction noise is anticipated to be temporary, transient, and comply with applicable standards of the City's Noise Ordinance (LAMC Chapter XI). The following mitigation measure would be implemented to ensure compliance:

**Mitigation Measure NOI1:** The contractor shall monitor construction activity adjacent to residential uses. Prior to the start of construction the contractor shall submit a noise monitoring plan for review and approval of the project manager. The plan shall include potential noise reduction measures to be implemented if needed to ensure compliance with the City's Noise Ordinance. Such measures may include but not be limited to the following:

- Temporary sound walls (noise barriers) of a sufficient height, length and configuration so as to provide substantial noise reduction and effectively block the line-of-sight between nearby noise-sensitive receivers and the work zone, and
- Limiting the number of construction equipment operating at one time.

Operation noise is anticipated to be limited to noise from the maintenance equipment, including trash pick up trucks. However, these activities would be implemented in accordance with applicable standards of the City's Noise ordinance. Additionally, trash pick up is an existing activity in the area. Noise increase from project operation is anticipated to have less

<b>Issues</b>	Potentially Significant Impact	Less Than Significant With	Less Than Significant	No Impact
---------------	--------------------------------	----------------------------	-----------------------	-----------

than a significant impact.

\* A-weighted decibel (dBA): an overall frequency-weighted sound level in decibels which approximates the frequency response of the human ear.

- b) Exposure of persons to or generation of excessive groundborne vibration or groundborne noise levels?

Reference: *City of Los Angeles General Plan, City of Los Angeles Municipal Code, L.A. CEQA Thresholds Guide* (Section I)

Comment: A significant impact may occur if the project were to expose persons to or generate excessive groundborne vibration or groundborne noise levels.

Construction activities associated with the project could generate groundborne vibration from use of heavy equipment. However, typically, activities such as pile driving would generate excessive vibration. No pile driving is anticipated adjacent to the residential uses. Excessive groundborne vibration is not anticipated.

- c) A substantial permanent increase in ambient noise levels in the project vicinity above levels existing without the project?

Reference: *City of Los Angeles General Plan, City of Los Angeles Municipal Code, L.A. CEQA Thresholds Guide* (Section I)

Comment: A significant impact may occur if the project were to substantially and permanently increase the ambient noise levels in the project vicinity above levels existing without the proposed project. See comments under 11 (a) above.

- d) A substantial temporary or periodic increase in ambient noise levels in the project vicinity above levels existing without the project?

Reference: *L.A. CEQA Thresholds Guide* (Section I)

Comment: A significant impact may occur if the project were to create a substantial temporary or periodic increase in the ambient noise levels in the project vicinity above levels existing without the proposed project.

See comments under 11 (a) above.

- e) For a project located within an airport land use plan or, where such a plan has not been adopted, within two miles of a public airport or public use airport, would the project expose people residing or working in the project area to excessive noise levels?

Reference: *General Plan, including the Venice Community Plan; L.A. CEQA Thresholds Guide* (Section I); *The Thomas Guide, Los Angeles County Street Guide* (2007)

Comment: The project is not anticipated to result in excessive noise levels. Refer to discussion under 11(a) above.

- f) For a project within the vicinity of a private airstrip, would the project expose people residing or working in the project area to excessive noise levels?

Reference: *General Plan, including the Venice Community Plan; L.A. CEQA Thresholds Guide* (Section I); *The Thomas Guide, Los Angeles County Street Guide* (2007)

Comment: No private airstrips are located within the vicinity of the project area.

**12. POPULATION AND HOUSING** – Would the project:

- a) Induce substantial population growth in an area, either directly (for

<h1>Issues</h1>	Potentially Significant Impact	Less Than Significant With	Less Than Significant	No Impact
-----------------	--------------------------------	----------------------------	-----------------------	-----------

example, by proposing new homes and businesses) or indirectly (for example, through extension of roads or other infrastructure)?

Reference: General Plan, including the *Venice Community Plan, L.A. CEQA Thresholds Guide* (Section J.1)

Comment: A significant impact may occur if the proposed project induced substantial population and housing growth through new development in undeveloped areas or by introducing unplanned infrastructure that was not previously evaluated in the adopted community plan or general plan.

The proposed project would not promote population growth either directly or indirectly, since it consists of infrastructure upgrades to meet regulatory requirements in conformance with the needs projected in the adopted community and general plans.

- |   |                          |                          |                          |                                     |
|---|--------------------------|--------------------------|--------------------------|-------------------------------------|
| <p>b) Displace substantial numbers of existing housing, necessitating the construction of replacement housing elsewhere?<br/>Reference: <i>L.A. CEQA Thresholds Guide</i> (Sections J.1 and J.2)<br/>Comment: No housing would be displaced or changed.</p> | <input type="checkbox"/> | <input type="checkbox"/> | <input type="checkbox"/> | <input checked="" type="checkbox"/> |
| <p>c) Displace substantial numbers of people, necessitating the construction of replacement housing elsewhere?<br/>Reference:<br/>Comment: See comment for 12 (b) above.</p>  | <input type="checkbox"/> | <input type="checkbox"/> | <input type="checkbox"/> | <input checked="" type="checkbox"/> |

**13. PUBLIC SERVICES –**

a) Would the project result in substantial adverse physical impacts associated with the provision of new or physically altered governmental facilities, need for new or physically altered governmental facilities, the construction of which could cause significant environmental impacts, in order to maintain acceptable service ratios, response times or other performance objectives for any of the public services:

- |  |                          |                          |                                     |                          |
|--|--------------------------|--------------------------|-------------------------------------|--------------------------|
| <p>i) Fire protection?<br/>Reference: <i>City of Los Angeles General Plan Safety Element, L.A. CEQA Thresholds Guide</i> (Section K.2)<br/>Comment: A significant impact may occur if the project required the addition of a new fire station or the expansion, consolidation or relocation of an existing facility to maintain service.</p> | <input type="checkbox"/> | <input type="checkbox"/> | <input checked="" type="checkbox"/> | <input type="checkbox"/> |
|--|--------------------------|--------------------------|-------------------------------------|--------------------------|

The proposed project would not require additional fire protection or emergency response services beyond what is currently provided. As per Bureau of Engineering Standard Project Specifications, construction activities would comply with applicable Fire Code requirements. The nearest local fire responders would be notified, as appropriate, of traffic control plans during construction so as to coordinate emergency response routing during construction work.

- |  |                          |                          |                                     |                          |
|--|--------------------------|--------------------------|-------------------------------------|--------------------------|
| <p>ii) Police protection?<br/>Reference: <i>City of Los Angeles General Plan Safety Element, L.A. CEQA Thresholds Guide</i> (Section K.1)<br/>Comment: A significant impact may occur if the proposed project were to result in an increase in demand for police services that would exceed the capacity of the police</p> | <input type="checkbox"/> | <input type="checkbox"/> | <input checked="" type="checkbox"/> | <input type="checkbox"/> |
|--|--------------------------|--------------------------|-------------------------------------|--------------------------|

<h1>Issues</h1>	Potentially Significant Impact	Less Than Significant With	Less Than Significant	No Impact
-----------------	--------------------------------	----------------------------	-----------------------	-----------

department responsible for serving the site.

The proposed project would not require additional police protection beyond what is currently provided. As per Bureau of Engineering Standard Project Specifications, construction activities would comply with applicable Municipal Code requirements. The nearest local police station would be notified, as appropriate, of traffic control plans during construction so as to coordinate emergency response routing during construction work.

iii) Schools?

Reference: *L.A. CEQA Thresholds Guide* (Section K.3)

Comment: A significant impact may occur if the proposed project included substantial employment or population growth that could generate demand for school facilities that exceeded the capacity of the school district responsible for serving the project site.

The proposed project is not a growth inducing project, either directly or indirectly, and would therefore not increase the demand for schools in the area.

iv) Parks?

Reference: *L.A. CEQA Thresholds Guide* (Section K.4)

Comment: A significant impact may occur if the recreation and park services available could not accommodate the population increase resulting from the implementation of the proposed project.

Operation of the proposed project is not a growth inducing project, either directly or indirectly, and would therefore not increase the demand for parks in the area.

During construction, one of the five baseball diamonds and associated field would be closed. The construction site would be isolated (e.g. temporary construction fencing) such that the other fields could be used. The temporary field closure (ten to twelve months) is anticipated to have minimal impact on Penmar Recreation Center activities (Guzman 2009). Several other organizations and clubs that use the facility would need to find temporary alternate locations. These organizations have been informed of the proposed project and have begun working together with the Penmar Recreation Center and other community members to find temporary locations for their activities. The project team will work with RAP to coordinate with the community and to keep them informed during the various stages for project implementation.

The field would be restored and the impact would be temporary.

v) Other public facilities?

Reference:

Comment: Operation of the proposed project would not induce growth, either directly or indirectly, and is therefore not anticipated to increase the demand or use for other public facilities in the area. As discussed above, during construction several clubs and organizations that currently use Penmar Recreation Center Field 5 would need to find alternate locations. Other parks and facilities within the area are anticipated to accommodate these users temporarily.

<h1>Issues</h1>	Potentially Significant Impact	Less Than Significant With	Less Than Significant	No Impact
-----------------	--------------------------------	----------------------------	-----------------------	-----------

**14. RECREATION –**

- a) Would the project increase the use of existing neighborhood and regional parks or other recreational facilities such that substantial physical deterioration of the facility would occur or be accelerated?

Reference: *L.A. CEQA Thresholds Guide* (Section K.4)

Comment: A significant impact may occur if the proposed project included substantial employment or population growth that generated demand for public park facilities that exceed the capacity of existing parks.

The proposed project is not a growth inducing project, either directly or indirectly, and would therefore not increase the demand for parks or other recreational facilities in the area. As indicated above, temporary impacts to Penmr Recreation Center and facilities within the vicinity would occur during construction. However, these would be temporary would be staged so as to minimize impacts.

- b) Does the project include recreational facilities or require the construction or expansion of recreational facilities that might have an adverse physical effect on the environment?

Reference:

Comment: The proposed project consists of improvements within an existing recreational facility and vicinity. A new facility, or expansion of the existing facility, is not proposed.

**15. TRANSPORTATION/TRAFFIC –** Would the project:

- a) Cause an increase in traffic that is substantial in relation to the existing traffic load and capacity of the street system (i.e., result in a substantial increase in either the number of vehicle trips, the volume to capacity ratio on roads, or congestion at intersections)?

Reference: *City of Los Angeles Penmar Water Quality and Runoff Reuse Project Negative Declaration Traffic Study, L.A. CEQA Thresholds Guide* (Section L.1 to L.4 and L.8)

Comment: A significant impact may occur if the proposed project caused an increase in traffic that would be substantial in relation to the existing traffic load and capacity of the street system.

The proposed project consists of improvements to an existing facility and adjacent stormdrain infrastructure. The project would generate a nominal number of vehicle trips during construction and operation.

Approximately 24,760 cubic yards of soil export are anticipated. Assuming trucks with 20 cubic yard capacity are used, approximately 1,240 truck trips would be generated. Haul routes and disposal locations would be determined by the construction contractor. Suitable soils may be used at other construction sites needing fill materials or may taken to disposal sites. Likely routes to be used include Rose Avenue, then south on Lincoln Boulevard to SR-90 or north on Lincoln Boulevard to the I-10 Freeway.

According to the traffic study conducted for this project, temporary construction impacts are anticipated. However, with implementation of the proposed traffic control plan for the main

<h1>Issues</h1>	Potentially Significant Impact	Less Than Significant With	Less Than Significant	No Impact
-----------------	--------------------------------	----------------------------	-----------------------	-----------

elements of the project, the same number of lanes would be maintained as such volume/capacity ratios are anticipated to be maintained. Concept control measures for the sewer rehabilitation are included in the recommendations of the traffic study. A traffic control plan for the sewer rehabilitation would also be developed in accordance with these recommendations to minimize potential impacts. Impacts would be temporary and are estimated to be less than significant.

b) Exceed, either individually or cumulatively, a level of service standard established by the county congestion management agency for designated roads or highways?  
Reference: See 15 (a).  
Comment: See 15 (a).

c) Result in a change in air traffic patterns, including either an increase in traffic levels or a change in location that results in substantial safety risks?  
Reference:  
Comment: The project does not involve any changes in air traffic patterns.

d) Substantially increase hazards due to a design feature (e.g., sharp curves or dangerous intersections) or incompatible uses (e.g., farm equipment)?  
Reference: *L.A. CEQA Thresholds Guide* (Section L.5)  
Comment: A significant impact may occur if the proposed project substantially increased road hazards due to a design feature or incompatible uses.

The proposed project does not propose any permanent changes to the surrounding street system and would not introduce incompatible vehicles to surrounding roadways. Temporary traffic control elements would be subject to review, including safety, and approval by Los Angeles Department of transportation.

e) Result in inadequate emergency access?  
Reference: *L.A. CEQA Thresholds Guide* (Section L.5 and L.8)  
Comment: A significant impact may occur if the proposed project resulted in inadequate emergency access.

The proposed project area is readily accessible from adjacent roadways. The project does not include any permanent changes or alterations to emergency access. As applicable, during construction, temporary lane changes would be subject to a traffic control plan, which would be subject to Los Angeles Department of Transportation review and approval, to ensure appropriate emergency access is maintained.

f) Result in inadequate parking capacity?  
Reference: *City of Los Angeles Penmar Water Quality and Runoff Reuse Project Negative Declaration Traffic Study, L.A. CEQA Thresholds Guide* (Sections L.7 & L.8)

Comment: No permanent impacts to parking are anticipated. In order to implement the proposed traffic control plan, temporary loss of parking adjacent to the construction area is anticipated. Along Rose Avenue, the temporary loss of parking spaces is anticipated to vary between 20 and 56 spaces as the construction progresses, see Appendix A for additional details. Along Oakwood Avenue, temporary loss of 16 to 26 parking spaces is anticipated for a period of



<h1>Issues</h1>	Potentially Significant Impact	Less Than Significant With	Less Than Significant	No Impact
-----------------	--------------------------------	----------------------------	-----------------------	-----------

three to six weeks. On Rialto Court, an estimated six houses may not have access to their garages for one to two nights during the sewer upgrade. Along Crescent Place at Palms Boulevard, a temporary loss of 11 parking spaces is anticipated for a period of two weeks. Along Abbot Kinney Boulevard at Palms Boulevard, temporary loss of six parking spaces is anticipated for a period of three to six weeks.

The loss of parking would only be temporary and is not anticipated to be substantial (FPI and Associates, Inc.). In accordance with standard construction practices, the temporary loss of parking would be posted in advance. Additionally, the following mitigation measure would be implemented:

**Mitigation Measure TRA1:** Contractor shall give advanced notice to the residences whose access to their garage will be impacted.

- g) Conflict with adopted policies, plans, or programs supporting alternative transportation (e.g., bus turnouts, bicycle racks)?

Reference:

Comment: A significant impact may occur if the proposed project were to conflict with adopted policies, plans, or programs supporting alternative transportation.

The designated bike lane along Rose Avenue would be temporarily removed as construction progresses. According to the traffic control plan, bicyclists would use the general purpose lane in the area impacted by construction. No other impacts are anticipated.

**16. UTILITIES AND SERVICE SYSTEMS –** Would the project:

- a) Exceed wastewater treatment requirements of the applicable Regional Water Quality Control Board?

Reference: *L.A. CEQA Thresholds Guide* (Section M.2)

Comment: A significant impact may occur if the proposed project exceeded wastewater treatment requirements of the local regulatory governing agency.

The Hyperion Treatment Plant is located on a 144-acre site adjacent to the Santa Monica Bay, southwest of the Los Angeles International Airport. The drainage area served by the plant is approximately 328,000 acres. Sewage from five major interceptor sewer systems, including the Venice Coastal Interceptor Sewer that serves the project area, is received and treated at this plant. According to the City's Bureau of Sanitation, the plant has sufficient capacity to accommodate the diverted stormwater flows.

- b) Require or result in the construction of new water or wastewater treatment facilities or expansion of existing facilities, the construction of which could cause significant environmental effects?

Reference: *L.A. CEQA Thresholds Guide* (Sections M.1 and M.2)

Comment: A significant impact may occur if the proposed project resulted in the need for new construction or expansion of water or wastewater treatment facilities that could result in an adverse environmental effect that could not be mitigated.

The proposed phase II of the project includes a disinfection system to treat a portion of the stormwater flow.

- c) Require or result in the construction of new storm water drainage facilities or expansion of existing facilities, the construction of which could cause

<h1>Issues</h1>	Potentially Significant Impact	Less Than Significant With	Less Than Significant	No Impact
-----------------	--------------------------------	----------------------------	-----------------------	-----------

significant environmental effects?  
Reference: *L.A. CEQA Thresholds Guide* (Section M.2)

Comment: A significant impact may occur if the volume of storm water runoff from the proposed project increases to a level exceeding the capacity of the storm drain system serving the project site.

The proposed project includes improvements to the existing stormwater infrastructure. The specific treatment design and methodology would be selected during the pre-design and design stages for that phase. Disinfection would be accomplished through chlorine, ozone, or ultraviolet treatment to meet applicable RWQCB-LA and/or the Los Angeles County Public Health requirements. No significant impacts are anticipated as a result of phase II implementation which is currently at a conceptual stage.

- d) Have sufficient water supplies available to serve the project from existing entitlements and resources, or are new or expanded entitlements needed?

Reference: *L.A. CEQA Thresholds Guide* (Section M.1)  
Comment: A significant impact may occur if the proposed project's water demands would exceed the existing water supplies that serve the site.

The City of Los Angeles Department of Water and Power provides potable water to the project area and vicinity. Other than temporary construction water use, the proposed project would not include new water uses.

- e) Result in a determination by the wastewater treatment provider that serves or may serve the project that it has adequate capacity to serve the project's projected demand in addition to the provider's existing commitments?

Reference:  
Comment: Refer to 16 (a) above.

- f) Be served by a landfill with sufficient permitted capacity to accommodate the project's solid waste disposal needs?

Reference: IRP EIR, *L.A. CEQA Thresholds Guide* (Section M.3)  
Comment: A significant impact may occur if the proposed project were to increase solid waste generation to a degree that existing and projected landfill capacities would be insufficient to accommodate the additional waste.

Demolition debris would be recycled at aggregate-base facilities, with residual debris disposed at inert landfills, the Bradley West landfill (which as of 2002 had 4,725,968 cubic yards capacity left) or Sunshine Canyon landfill (which as of 2001 had 16,000,000 cubic yards capacity left). It is anticipated that most of the excavated soil would be suitable for backfill. Unsuitable soil and soil that could not be used at other construction sites would be disposed at these landfills, where some of the soil may be suitable for use as needed daily cover.

During operation, trash and debris collected in the system would be removed an estimated three to six times a year. This would be a nominal volume and existing landfills have sufficient capacity to accommodate it.

- g) Comply with federal, state, and local statutes and regulations related to

<b>Issues</b>	Potentially Significant Impact	Less Than Significant With	Less Than Significant	No Impact
---------------	--------------------------------	----------------------------	-----------------------	-----------

solid waste?

Reference: *L.A. CEQA Thresholds Guide* (Section M.3)

Comment: A significant impact may occur if the proposed project would generate solid waste that was in excess of or was not disposed of in accordance with applicable regulations.

Solid waste disposal during construction and operation would comply with federal, state, local statutes and regulations related to solid waste.

**17. MANDATORY FINDINGS OF SIGNIFICANCE**

a) Does the project have the potential to degrade the quality of the environment, substantially reduce the habitat of a fish or wildlife species, cause a fish or wildlife population to drop below self-sustaining levels, threaten to eliminate a plant or animal community, reduce the number or restrict the range of a rare or endangered plant or animal or eliminate important examples of the major periods of California history or prehistory?

Reference: Preceding analyses

Comment: Construction may have a short-term, less than significant impact with implementation of mitigation as described above.

b) Does the project have impacts that are individually limited, but cumulatively considerable? (“cumulatively considerable” means that the incremental effects of a project are considerable when viewed in connection with the effects of past projects, the effects of other current projects, and the effects of probable future projects)?

Reference: Preceding analyses, *Santa Monica Airport Watershed Management Project*

Comment: BOE has not discovered any evidence that any impact of the proposed project could be significant when viewed in connection with the effects of other past, current, or future projects.

The City of Santa Monica is in the planning stage for several potential future projects within the Santa Monica Airport Watershed, which is part of the Rose Avenue Storm Drain drainage area, as described in the *Santa Monica Airport Watershed Management Project* report. BMPs and treatment trains including Airport Avenue landscaping, underground retention at three potential locations, Zinc Hangar runoff management, landscape modification in residential areas, and porous pavement on Pico Boulevard are included as potential projects. The Airport Watershed is one of the tributary areas of the proposed project.

The BMPs identified on the *Santa Monica Airport Watershed Management Project* report would improve the storm water quality closer to the pollutant source and could be considered related projects for the purposes of CEQA. However, due to the current status of these projects, which are in the very early planning stages and have not been approved for implementation, it is uncertain which of those projects are probable. As planning progresses, the City of Santa Monica would incorporate the proposed project into future analysis or evaluations of these BMPs. These Santa Monica BMP projects are not anticipated to overlap with the construction of the proposed project. Additionally, mitigation measures would be implemented, as applicable, to minimize impacts. The proposed project is not anticipated to result or contribute to cumulative impacts.

<b>Issues</b>	Potentially Significant Impact	Less Than Significant With	Less Than Significant	No Impact
---------------	--------------------------------	----------------------------	-----------------------	-----------

- c) Does the project have the potential to achieve short-term environmental goals to the disadvantage of long-term environmental goals?

Reference: Preceding analyses

Comment: The purpose of the proposed project is to improve both the short-term and long-term water quality of the receiving waters. The project is anticipated to have positive long term impacts to water quality.

- d) Does the project have environmental effects that will cause substantial adverse effects on human beings, either directly or indirectly?

Reference: Preceding analyses

Comment: With implementation of the mitigation measures listed below, the proposed project is not anticipated to have significant impacts that would cause substantial adverse effects on human beings, either directly or indirectly.

## V. MITIGATION MEASURES

The following mitigation measures form the foundation of a mitigation monitoring program (MMP) for the proposed project. CEQA requires public agencies to adopt a reporting or monitoring program for the changes to the project that have been adopted to mitigate or avoid significant effects on the environment (Public Resources Code Section 21081.6). The program must be adopted by the public agency at the time findings are made regarding the project. The State CEQA Guidelines allow public agencies to choose whether its program will monitor mitigation, report on mitigation, or both (14 CCR Section 15097(c)).

The mitigation measures described herein are supplemental to those required as standard procedure for the City and its contractors. The City and its contractors are the parties responsible for: (1) the necessary implementing actions; (2) verifying that the necessary implementing actions are taken; and (3) the primary record documenting the necessary implementing actions.

The mechanisms for verifying that mitigation measures have been implemented include design drawings, project plans and specifications, construction documents intended for use by construction contractors and construction managers, field inspections, field reports, and other periodic or special reports. All records pertaining to this mitigation program will be maintained and made available for inspection by the public in accordance with the City's records management systems.

### **Cultural Resources:**

**Mitigation Measure CUL1:** Archaeological monitoring by a qualified archaeological monitor shall be conducted during all ground-disturbing activities in connection with the proposed project until the archeological monitor deems there is a low potential for finding cultural materials. The archaeological monitor responsible for monitoring the Rialto Court/Crescent Place project area shall also be familiar with historic architectural resources. Ground-disturbing activities include, but are not limited to, pavement/asphalt removal, boring, trenching, grading, excavating, and foundation demolition.

**Mitigation Measure CUL2:** Prior to the commencement of construction activities, a Cultural Resources Monitoring and Mitigation Plan (CRMMP) shall be prepared. The CRMMP shall include, but not be limited to, construction monitoring protocol of all ground-disturbing project related construction activities; a construction worker training protocol and program; and cultural resource recovery and processing protocol if cultural resources are discovered. As applicable, the archaeological monitor shall follow the plan during construction.

**Mitigation Measure CUL3:** Upon completion of all ground-disturbing activities associated with the project, an Archaeological Resources Monitoring Report shall be prepared, documenting activities carried out under the CRMPP.

**Mitigation Measure CUL4:** Prior to any excavation in undisturbed soils (undisturbed alluvial deposits), a qualified paleontologist shall be retained to develop a monitoring and fossil remains treatment plan for construction-related activities that could disturb potential unique paleontological resources within the project area. The plan shall be implemented during construction and include, but not be limited to, the following:

- Authority for the paleontologist to halt, temporarily divert, or redirect grading in the area of an exposed fossil to facilitate evaluation and, if necessary, salvage.
- Provision for fossil identification and cataloguing before being donated to their final repository.
- Provision for the preparation of a report detailing results of the monitoring and treatment efforts, listing the fossils collected, and naming the repository.

**Noise:**

**Mitigation Measure NOI1:** The contractor shall monitor construction activity adjacent to residential uses. Prior to the start of construction the contractor shall submit a noise monitoring plan for review and approval of the project manager. The plan shall include potential noise reduction measures to be implemented if needed to ensure compliance with the City's Noise Ordinance. Such measures may include but not be limited to the following:

- Temporary sound walls (noise barriers) of a sufficient height, length and configuration so as to provide substantial noise reduction and effectively block the line-of-sight between nearby noise-sensitive receivers and the work zone, and
- Limiting the number of construction equipment operating at one time.

**Transportation/Traffic:**

**Mitigation Measure TRA1:** Contractor shall give advanced notice to the residences whose access to their garage will be impacted.

## VI. PREPARATION AND CONSULTATION

### A. Preparer

Maria E. Martin  
Environmental Supervisor I  
Environmental Management Group  
Bureau of Engineering  
Department of Public Works

Under Supervision of Jim Doty  
Environmental Supervisor II  
Environmental Management Group  
Bureau of Engineering  
Department of Public Works

### B. Coordination and Consultation

#### City of Los Angeles:

Department of Public Works  
Bureau of Engineering  
Proposition O Bond Program  
Edgar Mercado, Project Manager

Bureau of Sanitation  
Peter Tonthat

Brown and Caldwell  
(Design Consultant)  
Bob Finn, P.E.  
John R. Biggs, P.E.

Department of Recreation and Parks  
Paul Davis  
Juan Guzman

## VII. DETERMINATION - RECOMMENDED ENVIRONMENTAL DOCUMENTATION

### A. Summary

The City of Los Angeles is proposing to construct a stormwater diversion structure, primary and secondary pump station systems, a pretreatment system to screen trash, sediment, oil and grease; an underground detention reservoir, three force mains for flow conveyance within and adjacent to the Penmar Recreation Center in the Community of Venice. Minor upgrades to four sanitary sewer segments southwest of the recreation center are also proposed. Phase II of the project would provide further treatment for beneficial use. The proposed project would intercept and divert dry weather flows and portion of the wet weather stormwater flow from the existing Los Angeles County Storm Drain in Rose Avenue. Diverted flows would be conveyed to a pump station constructed within Frederick Street right-of-way northwest of the intersection with Rose Avenue. As sewer capacity allows, portion of the flow, including dry weather flow would be diverted directly to the sanitary sewer via a force main from the proposed pump station to the sanitary sewer and ultimately to the Hyperion Treatment Plant. Portion of the wet weather flow would be diverted via a second force main to an approximately 2.75-million gallon reservoir that would be constructed beneath the Penmar Recreation Center Field 5. Stormwater stored in the reservoir would be held in the reservoir for approximately seventy-two (72) hours after a storm event passes and then discharged at a controlled rate to the sanitary sewer through a combined gravity and pump system that would be constructed adjacent to the reservoir.

The minor sanitary sewer upgrades are proposed on Oakwood Avenue between Millwood Avenue and Rialto Court, on Rialto Court south of Nowita Place, Crescent Place (undeveloped street) between Rialto Court and Palms Boulevard, and on Abbot Kinney Boulevard at the intersection with Palms Boulevard. Phase II of the project would consist of disinfection to treat a portion of the stormwater flow for beneficial use for landscape irrigation at Pemar Golf Course, Penmar Recreation Center, and/or Marine Park.

Implementation of this project would help the City meet Santa Monica Bay Beaches Dry & Wet Weather Bacteria Total Maximum Daily Loads (TMDLs) adopted by the Water Quality Control Board to protect the designated beneficial uses of the receiving waters. The project is funded by Proposition O, a \$500 million Clean Water Bond Measure approved by voters November 5, 2004. The main goals of the project are to increase the beneficial and recreational uses of the receiving waters, reduce potential risks to human safety and health, reduce beach closures, and preserve aquatic and marine habitat.



**B. Recommended Environmental Documentation**

On the basis of this initial evaluation, I find that the project could not have a significant effect on the environment, and a **Mitigated Negative Declaration** should be adopted.

Prepared by: Original Signed by  
\_\_\_\_\_  
Maria E. Martin  
Environmental Supervisor I

Reviewed by: Original Signed by  
\_\_\_\_\_  
James E. Doty  
Environmental Supervisor II

Approved by: Original Signed by  
\_\_\_\_\_  
Ara Kasparian, Ph.D., Manager  
Environmental Management Group

AK/MM/CEQA IS20090515.doc

**VIII. REFERENCES:**

- American Public Works Association, Southern California Chapter. *Standard Specifications for Public Works Construction* (Greenbook).
- American Public Works Association, Southern California Chapter. 2001. *Work Area Traffic Control Handbook* (WATCH).
- ArchaeoPaleo Resources Management Inc. May 2009. *Cultural Resources Survey Report, Penmar Water Quality Improvement and Runoff Reuse Project, Prop O-Clean Water Bond Program, Community of Venice, City of Los Angeles, Los Angeles County, California.*
- Behrens and Associates Inc. March 27, 2009. *Penmar Water Quality Improvement Project Construction Noise Impact Evaluation Report.*
- Brown and Caldwell. May 7, 2009. Technical Memorandum: Air Quality Impact Assessment Using URBEMIS Modeling for Penmar Water Quality Improvement Project.
- California Air Pollution Control Officers Association. January 2008. *CEQA and Climate Change, Evaluating and Addressing Greenhouse Gas Emissions from Projects Subject to the California Environmental Quality Act.*
- California Department of Conservation (CDC), Div. of Land Resources Protection. 1997. *California Agricultural Land Evaluation and Site Assessment Model.*
- California, Department of Conservation, Division of Mines and Geology. State of California Seismic Hazard Zones, Torrance and San Pedro Quadrangles, released 3/25/1999. Accessed January 3, 2009 at CGS web sites [http://gmw.consrv.ca.gov/shmp/download/pdf/ozn\\_tor.pdf](http://gmw.consrv.ca.gov/shmp/download/pdf/ozn_tor.pdf) and [http://gmw.consrv.ca.gov/shmp/download/pdf/ozn\\_sped.pdf](http://gmw.consrv.ca.gov/shmp/download/pdf/ozn_sped.pdf)
- California, Department of Conservation (CDC), Division of Mines and Geology. Special Publication 42: "Fault Rupture Hazard Zones in California, Alquist-Priolo Earthquake Fault Zoning Act with Index to Earthquake Fault Zones Map". Released 1997, Supplemented in 1999, Interim revision 2007. Available at <http://www.consrv.ca.gov/CGS/rghm/ap/index.htm>
- California Department of Fish and Game. *California Natural Diversity Database*. Commercial Version, dated March 1, 2009.
- California Department of Transportation (CALTRANS) Landscape Architecture Program. California Scenic Highway Mapping System. Accessed January 2, 2009 at [http://www.dot.ca.gov/hq/LandArch/scenic\\_highways/index.htm](http://www.dot.ca.gov/hq/LandArch/scenic_highways/index.htm)

INITIAL STUDY  
PUBLIC WORKS – BUREAU OF ENGINEERING

California Environmental Protection Agency, Department of Toxic Substances Control Board (DTSC). EnviroStor Data Management System. Last accessed May 7, 2009 at <http://www.envirostor.dtsc.ca.gov>.

City of Los Angeles, *City of Los Angeles Municipal Code*.

City of Los Angeles, Department of City Planning. *General Plan*, including community plans and technical elements. Accessed various dates January through April, 2009 at <http://cityplanning.lacity.org>

City of Los Angeles, Department of City Planning. Planning and Zoning Code. Accessed various dates January through December, 2008 from City's web page at <http://cityofla.org/PLN/>

City of Los Angeles, Department of City Planning. ZIMAS (Zone Information & Map Access System). Accessed various dates through May 7, 2009 from City's web page at <http://zimas.lacity.org>

City of Los Angeles, Department of Public Works, BOE. November 2008. *Penmar Water Quality Improvement and Runoff Reuse Project, Final Pre-Design Report*. Prepared by Brown and Caldwell.

City of Los Angeles, Department of Public Works BOS. March 2007. *Penmar Water Quality Improvement and Runoff Reuse Project, Project Concept Report*.

City of Los Angeles, Department of Public Works BOS and Department of Water and Power. Prepared by CH:CDM. July 2004. *Integrated Resources Plan*.

City of Los Angeles, Department of Public Works BOS and Department of Water and Power. November 2005. *Integrated Resources Draft Environmental Impact Report (IRP DEIR)*.

City of Los Angeles, Environmental Affairs Department. 2006. *L.A. CEQA Thresholds Guide: Your Resource for Preparing CEQA Analyses in Los Angeles*. Available online at <http://lacity.org/ead/EADWeb-AQD/thresholdsguide.htm>

City of Los Angeles et al. 2005. *Santa Monica Bay Beaches Wet Weather Bacterial TMDL Implementation Plan*.

City of Santa Monica, Information Systems Department. Online Property Information System (OPIS) at [http://www01.smgov.net/isd/gis/interactive\\_maps/index.html](http://www01.smgov.net/isd/gis/interactive_maps/index.html)

Dallman, Suzanne, Ph.D. and Tom Piechota, Ph.D., P.E. *Stormwater: Asset Not Liability*. Los Angeles: LASGRWC, 1999. Available online at <http://www.lasgrwc.org/publications.html>

*INITIAL STUDY  
PUBLIC WORKS – BUREAU OF ENGINEERING*

Federal Emergency Management Agency, Flood Insurance Rate Map (FIRM), Community Panel Numbers 060137 0077 C (December 2, 1980) and 060137 0083 D (February 4, 1987); and FIRM Map Index Community Panels 060137 0001 – 0112 (May 4, 1999).

FPL and Associates, Inc. April 15, 2009. City of Los Angeles Penmar Water Quality and Runoff Reuse Project Negative Declaration Traffic Study.

Guzman, Juan (Facility Director, Penmar Recreation Center). April 23, 2009. Personal communication.

Ninyo & Moore. June 2008. *Geotechnical Evaluation Penmar Water Quality Improvement Project, Los Angeles, California.*

Technical Steering Committee (City of Los Angeles and County of Los Angeles, Co-Chairs). 2004. *Santa Monica Bay Beaches Bacterial TMDLs Coordinated Shoreline Monitoring Plan.* Available online at <http://dpw.lacounty.gov/wmd/NPDES/beachplan/FullBody.pdf>

U.S. Environmental Protection Agency EnviroMapper for Envirofacts accessed various dates through May 7, 2009 at <http://www.epa.gov/enviro/html/em/index.html>

U.S. Geological Survey (and California Geological Survey). 2006. Quaternary fault and fold database for the United States, accessed January 2009 at USGS web site: <http://earthquakes.usgs.gov/regional/qfaults/>.

U.S. Fish and Wildlife. FWS Critical Habitat for Threatened & Endangered Species data accessed January 2009 at <http://criticalhabitat.fws.gov/>

05 JUL 14 P2:19  
CITY OF SANTA MONICA  
CITY PLANNING/PPD

**NOTICE OF EXEMPTION**

TO:          State Clearinghouse  
1400 Tenth Street, Room 121  
Sacramento, CA 95814

FROM: City Planning Division  
City of Santa Monica  
1685 Main Street, Room 212  
Santa Monica, CA 90401

X County Clerk  
County of Los Angeles  
12400 East Imperial Highway  
Norwalk, CA 90650

**FILED**

JUN 14 2005

CONNOR B. MCCORMACK COUNTY CLERK  
J. Baker J. BAKER  
DEPUTY

**PROJECT TITLE:** Marine Park Storm Drain Project.

**PROJECT LOCATION (SPECIFIC):** Southern side of Marine Park, at 16<sup>th</sup> Street between Marine and Dewey Streets, located in an abandoned public right-of-way (16<sup>th</sup> Street).

**PROJECT LOCATION (CITY):** Santa Monica, California

**PROJECT LOCATION (COUNTY):** County of Los Angeles

**DESCRIPTION OF NATURE, PURPOSE, AND BENEFICIARIES OF PROJECT:**

The Marine Park storm drain project is a Best Management Practice to reduce urban runoff pollution into Santa Monica Bay. The project consists of a 3-stage urban runoff treatment and subsequent storage, reuse and infiltration of the treated water. Dry and wet weather runoff from the existing storm drain is treated for reuse or infiltration, thus enhancing water conservation efforts and reducing urban runoff pollution into Santa Monica Bay. The work is expected to begin in the Spring 2007 and be completed by Fall 2007.

Beneficiaries are the wildlife, marine animals and users and visitors of Santa Monica Bay.

City Council, City of Santa Monica

June 22, 2004

**NAME OF PUBLIC AGENCY APPROVING PROJECT**

**DATE OF PROJECT APPROVAL**

Neal Shapiro, Urban Runoff Management Coordinator, City of Santa Monica, EPWM Department

**NAME OF PERSON OR AGENCY CARRYING OUT PROJECT**

THIS NOTICE WAS POSTED  
ON JUN 14 2005  
UNTIL JUL 14 2005  
REGISTRAR-RECORDER/COUNTY CLERK

**EXEMPT STATUS: (Check One)**

- Ministerial
- Emergency
- Categorical Exemption
- General

**STATE GUIDE SECT.NO.**

15301(b); 15061(b)(3)

**REASONS WHY PROJECT IS EXEMPT:**

The Marine Park Storm Drain project is a Best Management Practice to reduce urban runoff pollution leaving the City of Santa Monica, entering the City of Los Angeles, and flowing directly into Santa Monica Bay from the Rose Avenue storm drain. Dry and wet weather runoff from the existing storm drain is treated for reuse or infiltration, thus reducing urban runoff pollution into Santa Monica Bay.

Section 15301(b) allows for the minor alterations to existing publicly-owned structures including utilities. In addition, Section 15061(b)(3) states that the provisions of CEQA only apply to those projects which have the potential to cause a significant adverse environmental impact. The lead agency has determined with certainty that the proposed project will not have a significant adverse impact on the environment and is, therefore, not subject to CEQA in that the proposed project involves the treatment and reuse of dry and wet weather runoff in an existing storm drain system to enhance water conservation efforts and improve the quality of Santa Monica Bay.

Neal Shapiro, Urban Runoff Management Coordinator/(310) 458-8223

**CONTACT PERSON/TELEPHONE**

6.9.05

**DATE OF EXEMPTION DETERMINATION**

*Armando Pacheco*  
Planning Manager



## The Clean Beaches and Ocean Parcel Tax Measure V Program

# 5-Year Capital Improvement Plan



**December 2009**



**B&V Project No. 162324**



**TABLE OF CONTENTS**

	<b>Page</b>
ABBREVIATIONS AND ACRONYMS .....	ii
1.0 INTRODUCTION.....	1
1.1 Background.....	1
1.2 Capital Improvement Plan Goals .....	1
2.0 PROJECT DESCRIPTIONS.....	2
2.1 Permeable Surface Alleys.....	3
2.2 Permeable Surface Street Gutters/Intersections .....	5
2.3 Miniature Parkway/Sidewalk Biofilters .....	7
2.4 Street Curb Extensions.....	8
2.5 Green Streets.....	9
2.6 Permeable Surface Parking Lots .....	10
2.7 Park Retrofits .....	12
2.8 Deep Infiltration In-Line Storm Drain Pilot Project .....	15
2.9 Payment on J-2/J-3 Agreement with City of Los Angeles.....	16
2.10 Trash BMPs .....	17
2.11 Downspout Redirect Program.....	22
2.12 Rain Barrel Program .....	23
2.13 Cistern Program.....	24
3.0 SUMMARY OF THE 5-YEAR CAPITAL IMPROVEMENT PLAN .....	25
4.0 REFERENCES.....	31

- Appendix A: List of Alleys
- Appendix B: Map of City Zones for Street Improvement Program & Locations of Existing Pervious Concrete Gutters
- Appendix C: Map of Ocean Park Boulevard Green Street Project Area
- Appendix D: Estimated Turf Irrigation Requirements in Santa Monica
- Appendix E: Park Retrofit Projects Conceptual Level Cost Opinions & Estimated Costs of Wet Season Harvesting Projects within the City of Santa Monica
- Appendix F: Review of Geotechnical Reports
- Appendix G: Pico-Kenter Trash BMPs Conceptual Level Cost Opinions for Alternatives 2 and 3
- Appendix H: Approximate Treated Areas and Reduction of Urban Runoff & Estimated Costs per Drainage Area Treated







## ABBREVIATIONS AND ACRONYMS

The following abbreviations and acronyms are used in this report.

AF	acre-feet
B&V	Black & Veatch
BMP	Best Management Practice
CASQA	California Stormwater Quality Association
EPA	United States Environmental Protection Agency
LARWQCB	Los Angeles Regional Water Quality Control Board
LID	Low Impact Development
O&M	Operations and Maintenance
OC	Measure V Citizens Oversight Committee
sf	square feet
TMDL	Total Maximum Daily Loads
WERF	Water Environment Research Foundation
WMP	Watershed Management Plan



## 1.0 INTRODUCTION

### 1.1 Background

#### Measure V

In November 2006, the Clean Beaches and Ocean Parcel Tax (Measure V) was passed by over two-thirds of voters in the City of Santa Monica (City). Measure V raises property tax revenue to be used solely for the purpose of implementing watershed water quality improvements in the City in accordance with the City's Watershed Management Plan (WMP) adopted in 2006.

#### 5-Year Capital Improvement Plan

Black & Veatch (B&V) was retained to assist the City with development of a 5-Year Plan (FY2010-11 through FY2014-15) for implementation of various stormwater best management practice (BMP) projects. Based on the Guidance List of BMP and Low Impact Development (LID) Strategies, which has been reviewed and approved by the Oversight Committee (OC) in June 2009, the following general categories of projects are proposed. A brief project description for each category of projects is provided in Chapter 2.

1. Permeable Surface Alleys
2. Permeable Surface Street Gutters/Intersections
3. Miniature Parkway/Sidewalk Biofilters
4. Street Curb Extensions
5. Green Streets
6. Permeable Surface Parking Lots
7. Park Retrofits
8. Deep Infiltration In-Line Storm Drain Pilot Project
9. Payment on J-2/J-3 Agreement with City of Los Angeles
10. Trash BMPs
11. Downspout Redirect Program
12. Rain Barrel Program
13. Cistern Program

As part of this effort, B&V was also retained to develop several initial alternatives for water quality improvements to the Pico-Kenter Watershed, in addition to the alternatives previously presented.

### 1.2 Capital Improvement Plan Goals

Upon successful completion of this 5-Year Capital Improvement Plan, it is anticipated that the following goals will be achieved:

- ▼ Approximately 1,200 acres of drainage area will be treated through various structural and non-structural BMP and LID strategies.
- ▼ Total urban runoff will be reduced by approximately 12.3 MG per year.
- ▼ An estimated 10.5 million gallons (MG) of water will be harvested and used for irrigation each year.



## 2.0 PROJECT DESCRIPTIONS

The following sections describe each category of projects. Where project-specific data is available, additional details are provided.



## 2.1 Permeable Surface Alleys

### Project Description

As part of routine alley replacement program, center swales will be replaced with a permeable surface, such as pervious concrete, to demonstrate the effective use of permeable products on the market. Three to five locations will be selected per year for this type of improvement. Measure V will fund the incremental cost between the regular concrete and pervious concrete or equivalent.

Appendix A presents a list of alleys that are scheduled for alley replacement for FY2009-10 through FY2013-2014. For planning purposes, the City is divided into five zones, and the alley replacement will be performed in one zone per fiscal year as follows:

- ▼ FY2009-10: Zone 1
- ▼ FY2010-11: Zone 2
- ▼ FY2011-12: Zone 3
- ▼ FY2012-13: Zone 4
- ▼ FY2013-14: Zone 5

### Reference Standard

California Stormwater Quality Association (CASQA) BMP Fact Sheets SD-20 will be utilized as guideline. Another option may include area drains at 50 feet apart with 2 foot gravel base to accommodate 3/4" rainfall.

Local site conditions shall be considered when designing and implementing these types of improvements to avoid issues associated with saturated soils. In some locations, subsurface conditions may require sub-drainage systems to relieve water to local storm drains or other means of drainage.

### Costs

An approximate unit cost for installation of pervious concrete is estimated to be \$9.3/sf (Water Environment Research Foundation, WERF). The unit cost includes construction costs, contingency, engineering, and construction management. Unit cost of regular concrete is estimated to be \$3.0/sf (RS Means). Thus, the guideline incremental cost of \$6.3/sf will be funded by Measure V.

Annual O&M costs associated with the water quality benefits derived from this application is estimated to be \$0.4/sf (WERF).

An initial guideline annual budget of \$70,000/year plus an escalation rate of 3% per year is allocated in the Measure V 5-Year Plan to implement this type of projects.

Table 2.1 shows a summary of the cost breakdown. It is estimated that approximately 8,000 to 10,000 sf or 4,000 to 5,000 linear feet of 2 foot wide center swales will be replaced each year.



**Table 2.1: Summary of Project Costs for Pervious Concrete Alleys**

	FY 2010 - 2011	FY 2011 - 2012	FY 2012 - 2013	FY 2013 - 2014	FY 2014 - 2015	Totals
<b>Installed Area (sf)</b>	10,448	9,829	9,238	8,688	8,161	<b>46,364</b>
<b>Unit Incremental Installation Cost* (\$/sf)</b>	\$6.5	\$6.7	\$6.9	\$7.1	\$7.3	-
<b>Unit Annual O&amp;M Cost* (\$/sf)</b>	\$0.4	\$0.4	\$0.4	\$0.5	\$0.5	-
<b>Capital Costs**</b>	\$67,796	\$65,695	\$63,599	\$61,601	\$59,601	<b>\$318,291</b>
<b>O&amp;M Costs</b>	\$4,304	\$8,605	\$12,901	\$17,199	\$21,499	<b>\$64,509</b>
<b>Total Project Costs</b>	\$72,100	\$74,300	\$76,500	\$78,800	\$81,100	<b>\$382,800</b>

\* Escalated at 3% per year.

\*\*Includes construction costs, contingency, engineering, and construction management.



## 2.2 Permeable Surface Street Gutters/Intersections

### Project Description

As part of routine street improvement program, concrete cross-gutters and intersections will be replaced with permeable products, such as pervious concrete, to demonstrate the effective use of different permeable products on the market. Measure V will fund the incremental cost between the regular concrete and pervious concrete or equivalent.

Pervious concrete street gutters have previously been installed in:

Oak Street and Hill Street between 18<sup>th</sup> and 25<sup>th</sup> Street  
Ashland Avenue between 23<sup>rd</sup> and 25<sup>th</sup> Street  
21<sup>st</sup> Street between Pearl Street and Pier Avenue  
Grant, Pacific and Maple Streets between 14<sup>th</sup> and 16<sup>th</sup> Street  
Washington Avenue between 26<sup>th</sup> and Stanford Street  
Harvard Street between Montana Avenue and Wilshire Boulevard

For planning purposes, the City is divided into five zones, and the street gutters/intersections replacement will be performed in one zone per fiscal year as follows:

- ▼ FY2010-11: Zone 7
- ▼ FY2011-12: Zone 1
- ▼ FY2012-13: Zone 2
- ▼ FY2013-14: Zone 3
- ▼ FY2014-15: Zone 4

Appendix B shows a map of the City zones for the street improvement program as well as the locations of the existing pervious concrete street gutters.

### Reference Standard

CASQA BMP Fact Sheets SD-20 will be utilized as guideline.

Local site conditions shall be considered when designing and implementing these types of improvements to avoid issues associated with saturated soils. In some locations, subsurface conditions may require sub-drainage systems to relieve water to local storm drains or other means of drainage.

### Costs

An approximate unit cost for installation of pervious concrete is estimated to be \$9.3/sf (WERF). The unit cost includes construction costs, contingency, engineering, and construction management. Unit cost of regular concrete is estimated to be \$3.0/sf (RS Means). Thus, the incremental guideline cost of \$6.3/sf will be funded by Measure V.

Annual O&M costs associated with the water quality benefits derived from this application is estimated to be \$0.4/sf (WERF).

An initial guideline annual budget of \$70,000/year plus an escalation rate of 3% per year is allocated in the Measure V 5-Year Plan to implement this type of projects.

Table 2.2 shows a summary of the cost breakdown. It is estimated that approximately 8,000 to 10,000 sf of street gutters/intersections will be replaced each year.



**Table 2.2: Summary of Project Costs for Pervious Concrete Gutter/Intersections**

	FY 2010 - 2011	FY 2011 - 2012	FY 2012 - 2013	FY 2013 - 2014	FY 2014 - 2015	Totals
<b>Installed Area (sf)</b>	10,448	9,829	9,238	8,688	8,161	<b>46,364</b>
<b>Unit Incremental Installation Cost* (\$/sf)</b>	\$6.5	\$6.7	\$6.9	\$7.1	\$7.3	-
<b>Unit Annual O&amp;M Cost* (\$/sf)</b>	\$0.4	\$0.4	\$0.4	\$0.5	\$0.5	-
<b>Capital Costs**</b>	\$67,796	\$65,695	\$63,599	\$61,601	\$59,601	<b>\$318,291</b>
<b>O&amp;M Costs</b>	\$4,304	\$8,605	\$12,901	\$17,199	\$21,499	<b>\$64,509</b>
<b>Total Project Costs</b>	\$72,100	\$74,300	\$76,500	\$78,800	\$81,100	<b>\$382,800</b>

\* Escalated at 3% per year.

\*\*Includes construction costs, contingency, engineering, and construction management.





## 2.3 Miniature Parkway/Sidewalk Biofilters

### Project Description

Where nuisance or dry season flow exists, demonstration-scale wetlands, tree wells, and other bioretention features will be installed to capture and utilize the runoff. A custom-designed system or a packaged system may be utilized. Larger applications favor custom-designed systems.

### Reference Standard

CASQA BMP Fact Sheets TC-32 will be utilized as guideline. Similar projects that have been implemented in the City of Portland could also be used as general guideline.

<http://www.portlandonline.com/bes/index.cfm?c=44463&>

### Suggested Products and Suppliers

MWS by Bioclean Environmental Services. <http://www.biocleanenvironmental.com>

Bioretention System by Filterra. <http://www.filterra.com>

Tree Wells and Biofilters by Contech. <http://www.contech-cpi.com>

Treepod Biofilter by Kristar. <http://www.kristar.com/>

### Costs

An approximate unit cost for installation of bioretention features is estimated to be \$70,000/acre of drainage area (WERF). The unit cost includes construction costs, contingency, engineering, and construction management.

Annual O&M cost is estimated to be \$10,000/acre of drainage area (WERF).

An initial guideline annual budget of \$100,000/year plus an escalation rate of 3% per year is allocated in the Measure V 5-Year Plan to implement this type of projects.

Table 2.3 shows a summary of the cost breakdown. It is estimated that the City will be able to install bioretention features that would treat approximately 0.7 to 1.3 acres of drainage area each year.

**Table 2.3: Summary of Project Costs for Miniature Parkway/Sidewalk Biofilters**

	FY 2010 - 2011	FY 2011 - 2012	FY 2012 - 2013	FY 2013 - 2014	FY 2014 - 2015	Totals
<b>Drainage Area Treated (acres)</b>	1.3	1.1	1.0	0.8	0.7	<b>4.9</b>
<b>Unit Installation Cost* (\$/acre)</b>	\$72,100	\$74,263	\$76,491	\$78,786	\$81,149	-
<b>Unit Annual O&amp;M Cost* (\$/acre)</b>	\$10,300	\$10,609	\$10,927	\$11,255	\$11,593	-
<b>Capital Costs**</b>	\$90,125	\$81,234	\$73,227	\$66,014	\$59,427	<b>\$370,027</b>
<b>O&amp;M Costs</b>	\$12,875	\$24,866	\$36,073	\$46,586	\$56,473	<b>\$176,873</b>
<b>Total Project Costs</b>	\$103,000	\$106,100	\$109,300	\$112,600	\$115,900	<b>\$546,900</b>

\* Escalated at 3% per year.

\*\*Includes construction costs, contingency, engineering, and construction management.







## 2.4 Street Curb Extensions

### Project Description

In this application, the street curb is extended at the downstream end of streets to install wider, depressed landscaping to capture and retain runoff; these extensions will include climate-appropriate plants and drip irrigation. Installation of a cistern will be considered where suitable to supply water for onsite landscaping. Runoff would be captured in one location rather than distributed along the street.

### Reference Standard

CASQA BMP Fact Sheets TC-12, TC-32 and SD-11 will be utilized as guideline.

### Suggested Products and Suppliers

A list of cistern system suppliers can be found at the City's website:

[http://www.smgov.net/uploadedFiles/Departments/OSE/Categories/Urban\\_Runoff/Barrel\\_Cistern\\_Supplierslist%204-22.pdf](http://www.smgov.net/uploadedFiles/Departments/OSE/Categories/Urban_Runoff/Barrel_Cistern_Supplierslist%204-22.pdf)

As with many water quality features, larger applications favor the development of a custom-designed facility.

### Costs

An approximate unit cost for installation of curb contained bioretention features is estimated to be \$70,000/acre of drainage area (WERF). The unit cost includes construction costs, contingency, engineering, and construction management. Additional cost for a cistern and irrigation system will be determined once specific project locations are selected. For the purpose of the 5-Year Plan, \$50,000 is allocated per project to cover the costs for the cistern and irrigation system in addition to the costs associated with the bioretention features.

Annual O&M cost is estimated to be \$10,000/acre of drainage area for the bioretention features and \$12,000/acre for a cistern and irrigation system (WERF).

An initial guideline annual budget of \$100,000/year plus an escalation rate of 3% per year is allocated in the Measure V 5-Year Plan to implement this type of projects.

Table 2.4 shows a summary of the cost breakdown. It is estimated that the City will be able to install bioretention features with a cistern system to treat approximately 0.2 to 0.5 acres of drainage area each year.

**Table 2.4: Summary of Project Costs for Street Curb Extensions**

	FY 2010 - 2011	FY 2011 - 2012	FY 2012 - 2013	FY 2013 - 2014	FY 2014 - 2015	Totals
<b>Drainage Area Treated (acres)</b>	0.5	0.4	0.3	0.2	0.2	<b>1.7</b>
<b>Unit Installation Cost for Bioretention* (\$/acre drainage area treated)</b>	\$72,100	\$74,263	\$76,491	\$78,786	\$81,149	-
<b>Allocation for Additional Costs* (Cistern, Irrigation, etc.)</b>	\$51,500	\$53,045	\$54,636	\$56,275	\$57,964	-
<b>Unit Annual O&amp;M Cost for Bioretention, Cistern, and Irrigation*</b>	\$22,660	\$23,340	\$24,040	\$24,761	\$25,504	-
<b>Capital Costs**</b>	\$90,685	\$83,762	\$78,722	\$75,167	\$72,710	<b>\$401,045</b>
<b>O&amp;M Costs</b>	\$12,315	\$22,338	\$30,578	\$37,433	\$43,190	<b>\$145,855</b>
<b>Total Project Costs</b>	\$103,000	\$106,100	\$109,300	\$112,600	\$115,900	<b>\$546,900</b>

\* Escalated at 3% per year.

\*\*Includes construction costs, contingency, engineering, and construction management.





## 2.5 Green Streets

### Project Description

Ocean Park Boulevard Green Street Project will include implementation of various LID features, such as permeable gutters, sub-surface infiltration, permeable parking lanes, depressed parkways with drip irrigation and climate-appropriate plants, curb extensions, and depressed planters to capture runoff. A map of the project area is included in Appendix C. It is anticipated that construction of this project will start in 2011.

It is currently planned that \$1M of the total project capital costs, O&M costs, and other associated costs will be funded by Measure V in support of water quality benefits provided by the project. If implementation of the Ocean Park Blvd. Green Street Project is found infeasible due to funding or other issues, retrofits at Los Amigos Park and Parking Lot 9A or 11 will be considered as an alternate project. Concept for the alternate project is to divert runoff from the middle section of the sub drainage area to Los Amigos Park, capture runoff, and use the harvested flow for irrigation. Similarly, runoff from the southwesterly section of the sub drainage area would be diverted to Parking Lot 9A or 11, which is located on Neilson Way, and the runoff would be captured for infiltration, if deemed feasible.

### Reference Standard

CASQA BMP Fact Sheets TC-32 and SD-20 will be utilized as guideline. Bicknell Green Street Project will also be used as a model.

### Costs

It is assumed that \$700,000 and \$300,000 will be expended in FY2010-2011 and FY2011-12, respectively, to cover the capital costs. Annual maintenance cost is estimated to be \$7,000/acre of drainage area (WERF). Annual O&M cost associated with water quality benefits are estimated to be \$21,000 based on the drainage area of approximately 3 acres (WERF).

Table 2.5 shows a summary of the cost breakdown.

**Table 2.5: Summary of Project Costs for Green Streets**

	FY 2010 - 2011	FY 2011 - 2012	FY 2012 - 2013	FY 2013 - 2014	FY 2014 - 2015	Totals
<b>Capital Costs*</b>	\$700,000	\$300,000	\$0	\$0	\$0	<b>\$1,000,000</b>
<b>O&amp;M Costs**</b>	\$0	\$22,279	\$22,947	\$23,636	\$24,345	<b>\$93,207</b>
<b>Total Project Costs</b>	\$700,000	\$322,279	\$22,947	\$23,636	\$24,345	<b>\$1,093,207</b>

\*Includes construction costs, contingency, engineering, and construction management.

\*\* Escalated at 3% per year.



## 2.6 Permeable Surface Parking Lots

### Overview

As part of City's overall facility program, permeable surfaces, such as porous asphalt, will be utilized for retrofit or new city parking facilities to demonstrate the effective use of different permeable products on the market. Depressed planters will also be implemented to capture runoff. Measure V will cover the portion of the project cost that is associated with the stormwater quality enhancement (i.e. depressed planters and incremental cost between the regular asphalt and porous asphalt).

The installation cost is estimated based on an incremental unit cost of \$0.80/sf (\$1.4 for permeable asphalt and \$0.6 /sf for regular asphalt) and an allocation of \$10,000/acre of parking lot for depressed planters. Annual O&M cost associated with the water quality benefits derived from this application are estimated to be \$0.2/sf (WERF). The following parking lots are planned for resurfacing and re-stripping in FY2011-12.

### Parking Lot 9

- ▼ *Project Location.* Parking Lot 9 is located eastside of Neilson Way between Ashland Avenue and Hill Street.
- ▼ *Lot Size.* 1.55 acres
- ▼ *Installation Costs.* \$73,685
- ▼ *Annual O&M Costs.* \$14,314\*

### Parking Lot 9A

- ▼ *Project Location.* Parking Lot 9A is located eastside of Neilson Way from Hill Street to mid-block.
- ▼ *Lot Size.* 1.2 acres
- ▼ *Installation Costs.* \$57,047
- ▼ *Annual O&M Costs.* \$11,082\*

### Parking Lot 11

- ▼ *Project Location.* Parking Lot 11 is located eastside of Neilson Way between Ocean Park Boulevard and Hollister Avenue.
- ▼ *Lot Size.* 1.3 acres
- ▼ *Installation Costs.* \$61,801
- ▼ *Annual O&M Costs.* \$12,005\*

### Parking Lot 26

- ▼ *Project Location.* Parking Lot 26 is a small lot located eastside of Neilson Way between Hollister Avenue and Strand Street (most of the block is community gardens).
- ▼ *Lot Size.* 0.16 acres
- ▼ *Installation Costs.* \$7,606
- ▼ *Annual O&M Costs.* \$1,478\*

\*FY2011-12 O&M costs based on escalation at 3% per year.

### Reference Standard

CASQA BMP Fact Sheets SD-20 will be utilized as guideline.

Local site conditions shall be considered when designing and implementing these types of improvements to avoid issues associated with saturated soils. In some locations, subsurface conditions may require sub-drainage systems to relieve water to local storm drains or other means of drainage.



Table 2.6 shows a summary of the cost breakdown.

**Table 2.6: Summary of Project Costs for Porous Asphalt Parking Lots**

	FY 2010 - 2011	FY 2011 - 2012	FY 2012 - 2013	FY 2013 - 2014	FY 2014 - 2015	Totals
<b>Installed Area (acres)</b>	0.0	4.2	0.0	0.0	0.0	<b>4.2</b>
<b>Unit Incremental Installation Cost for Porous Asphalt* (\$/sf)</b>	-	\$0.8	-	-	-	-
<b>Planter Costs (\$10,000/acre*)</b>	\$0	\$44,664	\$0	\$0	\$0	-
<b>Unit Annual O&amp;M Cost* (\$/sf)</b>	-	\$0.2	\$0.2	\$0.2	\$0.2	-
<b>Capital Costs**</b>	\$0	\$200,309	\$0	\$0	\$0	<b>\$200,309</b>
<b>O&amp;M Costs*</b>	\$0	\$38,911	\$40,079	\$41,281	\$42,519	<b>\$162,790</b>
<b>Total Project Costs</b>	\$0	\$239,220	\$40,079	\$41,281	\$42,519	<b>\$363,098</b>

\* Escalated at 3% per year.

\*\*Includes construction costs, contingency, engineering, and construction management.



## 2.7 Park Retrofits

### Overview

As part of these projects, wet weather runoff from a main storm drain will be diverted to an adjacent park for treatment (pretreatment and disinfection), storage, and use as irrigation water within the park. A replicable model will be developed and used throughout the City.

It is currently assumed that a vortex separator or equivalent will be provided for pretreatment, and a tank will be used for storage.

Data from the California Irrigation Management Information System (CIMIS), which is included in Appendix D, was utilized to estimate the typical turf watering requirements in Santa Monica during the wet season. The size of the storage tank at each project location was estimated based on the 6-month average (October through March) irrigation requirement of 1.8 inches/month, the approximate turf area at each park, and 2 weeks of storage period required between storm events.

The following locations are considered for park retrofits.

### Memorial Park

- ▼ *Project Description.* Memorial Park is a multi-purpose Park located centrally within the City. The City is planning to construct a 1 MG buried non-potable water reservoir and a pump station at Memorial Park to improve the operational flexibility, reliability and performance of their existing non-potable water system. This reservoir will provide additional storage in the system for SMURRF effluent to meet potential peak system demands, and the booster pump station would eliminate existing pressure problems. In conjunction with this planned project, the City is proposing to construct a stormwater harvesting and use facility at this Park to divert some of the wet weather flows from the Kenter Storm Drain, retain and treat the flow, and utilize the harvested water for Park irrigation and other non-potable uses in nearby areas. As Memorial Park is located adjacent to the Kenter Storm Drain, which carries flows from a significant drainage area within the Kenter Canyon Basin, it is one of the most suitable locations within the City to implement a stormwater diversion and harvesting project. The stormwater harvesting system will likely include:
  - A diversion structure
  - A submersible pump station for conveying stormwater to the park
  - A pre-treatment system for trash and sediment removal
  - A below-grade tank
  - A strainer and disinfection system
  - A pumping facility for irrigation
  - Site piping for irrigation (modifications to and/or replacement of the existing piping)
  - Irrigation system improvements (modifications to and/or replacement of the existing system)

As both projects will require a below-grade tank and a pump station, it would be cost effective to combine the two projects. A dual reservoir with two compartments (hydraulically isolated) with a divider wall in the middle could be constructed, in lieu of two separate reservoirs. By the logic outlined above, it is estimated that a 200,000-gallon tank would be required in this application.

- ▼ *Capital Costs.* \$3.7M including construction, design, and construction management costs.
- ▼ *Annual O&M Costs.* \$25,000
- ▼ *Schedule.* It is anticipated that the stormwater harvesting facility will be constructed concurrently with construction of the non-potable reservoir for SMURRF effluent, which is currently scheduled for FY2012-13.



### Ozone Park

- ▼ *Project Description.* Ozone Park is located within the Lincoln Basin near the City boundary with the City of Los Angeles. A stormwater harvesting and use facility similar to the one proposed for Memorial Park is considered. It is estimated that a 15,000-gallon tank would be required in this application.
- ▼ *Capital Costs.* \$845,000 including construction, design, and construction management costs.
- ▼ *Annual O&M Costs.* \$20,000
- ▼ *Schedule.* It is anticipated that the facility will be constructed in FY2010-11.

### Marine Park

- ▼ *Project Description.* Marine Park is located within the 16<sup>th</sup> Street Basin near the City boundary. Upon completion of Phase 2 (the recycled component) of the Penmar Project (City of Los Angeles), a non-potable water pipeline could be extended from the reservoir at the Penmar project site to Marine Park for use of the captured stormwater.
- ▼ *Capital Costs.* \$1.0M including construction, design, and construction management costs.
- ▼ *Annual O&M Costs.* \$20,000
- ▼ *Schedule.* It is anticipated that the facility will be constructed in FY2011-12.

### Virginia Park

- ▼ *Project Description.* Virginia Avenue Park is located within the Pico-Caltrans Basin south of the 10 Freeway. The City is considering a stormwater harvesting and use facility similar to the one proposed for Memorial Park. It is estimated that a 65,000-gallon tank would be required in this application.
- ▼ *Capital Costs.* \$1.9M including construction, design, and construction management costs.
- ▼ *Annual O&M Costs.* \$20,000
- ▼ *Schedule.* It is anticipated that the facility will be constructed in Post-2015.

### Reed Park

- ▼ *Project Description.* Reed Park is located within the Wilshire Basin. The City is considering a stormwater harvesting and use facility similar to the one proposed for Memorial Park. It is estimated that a 40,000-gallon tank would be required in this application.
- ▼ *Capital Costs.* \$1.7M including construction, design, and construction management costs.
- ▼ *Annual O&M Costs.* \$20,000
- ▼ *Schedule.* It is anticipated that the facility will be constructed in Post-2015.

### Clover Park

- ▼ *Project Description.* Clover Park is located within the Airport Basin. The City is considering a stormwater harvesting and use facility similar to the one proposed for Memorial Park. It is estimated that a 200,000-gallon tank would be required in this application.
- ▼ *Capital Costs.* \$5.3M including construction, design, and construction management costs.
- ▼ *Annual O&M Costs.* \$25,000
- ▼ *Schedule.* It is anticipated that the facility will be constructed in Post-2015.

### Los Amigos Park

- ▼ *Project Description.* Los Amigos Park is located within the Pico-4<sup>th</sup> Street Basin. The City is considering a stormwater harvesting and use facility similar to the one proposed for Memorial Park. Retrofits at Los Amigos Park will be considered as an alternative project, if implementation of the Ocean Park Boulevard Green Street Project is found infeasible due to funding or other issues.

A conceptual level cost opinion for each of the park retrofit projects is included in Appendix E.



During the OC meeting held in September 2009, the OC requested that an estimated unit cost for stormwater harvesting at each park be provided (in \$/ac-ft) for comparison with cost of potable water. This information is provided in Appendix E.

#### Reference Standard

CASQA BMP Fact Sheets TC-12, TC-32 and SD-11 will be utilized as guideline.

#### Suggested Products and Suppliers

A list of cistern system suppliers can be found at the City's website:

[http://www.smgov.net/uploadedFiles/Departments/OSE/Categories/Urban\\_Runoff/Barrel\\_Cistern\\_Supplierslist%204-22.pdf](http://www.smgov.net/uploadedFiles/Departments/OSE/Categories/Urban_Runoff/Barrel_Cistern_Supplierslist%204-22.pdf). A package system may be considered in some applications; however, these larger applications may find benefits in a custom-designed facility.



## **2.8 Deep Infiltration In-Line Storm Drain Pilot Project**

### Project Description

A pilot-scale aquifer recharge system will be considered to infiltrate dry and wet weather runoff from a storm drain via deep infiltration wells. B&V reviewed geotechnical reports made available by the City to assess general surface soil conditions within the City area. A summary of the geotechnical reports review is provided in Appendix F. Geologic reconnaissance will be performed to further assess feasibility of such project and to develop concept.

### Costs

It is assumed that \$100,000 plus an escalation rate of 3% per year will be allocated to perform the geologic reconnaissance and develop concept(s) in FY2010-11.





## **2.9 Payment on J-2/J-3 Agreement with City of Los Angeles**

### Project Description

Per the *Draft Memorandum of Agreement (MOA) with the City of Los Angeles for the Santa Monica Bay Beaches Wet Weather Bacterial TMDL Implementation Plan Projects Cost Sharing Jurisdictional Groups Two and Three*, dated August 2007, it is currently assumed that the City of Santa Monica will contribute a total of \$4M over a 20-year term towards implementation of a series of City of Los Angeles projects in the jurisdictions, including the Penmar Water Quality Improvement Project.

### Costs

It is assumed that \$200,000/year plus an interest rate of 3.25% per year will be paid to the City of Los Angeles over the next 20 years.



## 2.10 Trash BMPs

### Project Description

In order to achieve compliance with a Santa Monica Bay trash TMDL, trash BMPs, such as vortex separators or inlet filter/inserts, will be installed to reduce the amount of trash entering the Bay upon storm events.

Reducing the amount of trash discharged from Pico-Kenter Outlet is considered as the primary focus of the City's trash BMP implementation in the next 5 years. Three basins (Kenter Canyon, Pico-Caltrans, and Pico-4<sup>th</sup> Street Basins) totaling over 4,000 acres drain to the Pico-Kenter Outlet, and limited trash BMPs have been implemented in these basins to date. Approximately 2/3 (or 2,645 acres) of Kenter Canyon Basin, which is the largest of the three basins, is located within the City of Los Angeles.

The following three alternatives are considered for trash BMPs for the three basins (collectively referred as Pico-Kenter Watershed) that discharge to the Pico-Kenter Outlet.

- ▼ Alternative 1. Install catch basin screening throughout watershed. It assumed that all of the City of Santa Monica owned catch basins within Pico-Kenter Watershed without inserts/filters will be retrofitted with inserts/filters in the first phase of implementation. In the second phase of implementation, the City will coordinate with the County of Los Angeles, City of Los Angeles, and other entities to retrofit the remainder of the catch basins within the Watershed.
- ▼ Alternative 2. Install five vortex separators at the Pico-Kenter Outlet. All separators will be installed at once.
- ▼ Alternative 3. Install five vortex separators at the Pico-Kenter Outlet. The five separators will be installed in phases. In FY2010-11, one unit will be installed at the northwest side of the outlet. In FY2012-13, another unit will be installed at the southeast side of the outlet. In FY2014-15, three additional units will be installed at the northwest side of the outlet.

A breakdown of the ownership and retrofit costs are summarized in Table 2.10-1.

**Table 2.10-1: Cost for Filters/Inserts for Catch Basins throughout the Pico-Kenter Watershed**

		with Inserts/ Filters	without Inserts/ Filters	Capital Cost to Add Inserts/ Filters*	Total Catch Basins within Watershed	Annual Cost to Maintain Inserts/ Filters**
Watershed with in Santa Monica	Catch Basins Owned by Santa Monica***	25	284	\$766,800	309	\$93,373
	Catch Basins Owned by Others	0	514	\$1,387,800	514	\$155,319
Watershed outside Santa Monica	Catch Basins Owned by Others	0	366	\$988,200	366	\$110,597
	<b>Totals</b>	25	1,164	<b>\$3,142,800</b>	1,189	<b>\$359,300</b>

\* Based on estimated installed cost of \$2,700 per catch basin (based on quote from Bio-Clean with an 80% allowance to account for contingencies). Program oversight and administrative costs of \$98,000/year to be included in annual expenditure schedule in addition to the filter/insert costs.

\*\* Maintenance costs developed with 3 cleaning/year with a 2 person crew spending 1/2 hour per catch basin. Labor costs estimated at \$35/hour/person. Vactor operating costs estimated at \$130/hour. Solids disposal cost at \$66/ton. Solids generation of 66 lbs/catch basin is assumed based on data provided by the City.

\*\*\* All catch basins owned by the City of Santa Monica are considered to be Phase 1.





### Costs

In order to compare the long-term overall project costs of the three alternatives, a 20-year present-worth cost analysis was performed, as summarized in Table 2.10-2. In addition, advantages of each alternative are also summarized in Table 2.10-2.



**Table 2.10-2: Pico-Kenter Watershed Treatment Alternatives – Summary Cost Comparison**

Alt.	Description	Location(s)	Project Summary	Advantages	Phase 1 Project Cost** (\$)	Phase 2 Project Cost (\$)	Phase 3 Project Cost (\$)	Total of All Phases (\$)	Annual O&M Cost* (\$)	20-Year PW Cost @ 6% (\$)
1	Catch Basin Screening	Throughout watershed	Screens at all catch basins within the watershed.	Intercepts flow further up in the watershed; may distribute maintenance between agencies better.	\$1,002,900	\$2,376,000	\$0	\$3,378,900	\$360,000	\$8,451,000
2	End of Pipe	Discharge at the Beach	Concept for five 64 cfs vortex separators at the foot of Pico Blvd. All five separators will be installed at once.	Single site; economy of scale.	\$7,200,000	\$0	\$0	\$7,200,000	\$35,000	\$7,694,000
3	Phased End of Pipe	Discharge at the Beach	Phased concept to implement a total of five 64 cfs vortex separators at the foot of Pico Blvd. In FY2010-11, one unit will be installed at the northwest side of the outlet. In FY2012-13, another unit will be installed at the southeast side of the outlet. In FY2014-15, three additional units will be installed at the northwest side of the outlet.	Single site; phasing allows for incremental addition and improvement.	\$3,812,000	\$2,342,000	\$3,536,000	\$9,690,000	\$35,000	\$10,184,000

\* See Table 2.10-1 for development of Alternative 1 O&M costs. For Alternatives 2 & 3, four cleanings/yr with a 2 person crew, spending 4 hour per vortex separator assumed. Solids capture was the same by area as with Alternative 1.

\*\*Costs include sanitary sewer diversion and improvements to dry weather diversion at the Pico-Kenter Pump Station. The total project cost for these improvements are estimated to be \$236,100.





Although Alternative 2 (i.e. a regional facility) demonstrates long-term cost effectiveness, the upfront cost of over \$7M would consume over 3 years of revenues from Measure V. The phasing approach in Alternative 3 allows for incremental addition and improvements; however, the total project cost is high due to escalation factors and reduced economy of scale. As a result, per direction of the City, Alternative 1 is currently proposed, as this option will allow for trash to be captured further up stream and may distribute maintenance better between agencies.

It is assumed that the first phase of implementation, which is to install inserts/filters in all of the City of Santa Monica owned catch basins within Pico-Kenter Watershed, will be included in this 5-Year Plan. The first phase of project will be implemented in FY2010-11 and FY2011-12 with a capital cost of \$1,002,900. The Phase 1 project cost includes costs for addition of sanitary sewer diversion capability and improvements to the existing dry weather diversion piping at the Pico-Kenter Pump Station, which are estimated to be \$236,100. The improvements include addition of a forcemain from the pump station routed to a sewer manhole, which would allow for diversion of dry weather runoff to sanitary sewer when SMURRF is out of service. Improvements to the existing diversion piping would allow for more reliable diversion of dry weather runoff to SMURRF. Annual O&M cost is estimated to be \$93,400 for Phase 1. The costs associated with the second phase of implementation (i.e. retrofit of catch basins owned by other agencies) are not included in this 5-Year Plan.

Additional details on the conceptual level cost opinions for Alternatives 2 and 3 are provided in Appendix G.

Other Alternatives

Two other alternatives, as summarized in Table 2.10-3, were also considered. However, due to cost and complexity, these alternatives were not carried forward in the evaluation.

**Table 2.10-3: Other Alternatives Initially Considered  
 (but not carried forward due to cost and complexity)**

Description	Location(s)	Project Summary	Advantages
Memorial Park + Phased End of Pipe*	Memorial Park + Discharge at the Beach	Capture and use of wet season flows at Memorial Park with phased concept for multiple vortex separators at the foot of Pico Blvd. Over \$12M in capital costs. O&M costs could exceed \$75,000/year.	Beneficial use of wet season flows; some benefits of sharing the site with planned 1 mgd non-potable reservoir for SMURRF effluent at Memorial Park; may allow for additional storage and more effective use of dry season flows.
Brentwood + Memorial Park + Downstream Sub watersheds	Brentwood + Memorial Park + Downstream Sub watersheds	Capture and use of wet season flows at Brentwood and Memorial Park with vortex separators downstream watersheds (Pico-Caltrans, Pico 4th and drainage at the foot of Pico Blvd.) Over \$18M in capital costs. O&M costs could exceed \$75,000/year.	Similar to above; may reduce size of the Pico Blvd. facility.

\*The stormwater harvesting component of this alternative will be carried forward as part of the Memorial Park Retrofit Project, as described under Section 2.7.





### Other Considerations

During the OC meeting held in September 2009, it was requested that a hybrid option that implements both catch basin screening and vortex separators be also considered. It was suggested that this hybrid facility could be located either near the beach (similar to Alternatives 2 and 3) or near the City boundary with the City of Los Angeles. It was surmised that this approach may help address uncertainties associated with how the other agencies within the Pico-Kenter Watershed may implement TMDL measures in the future (i.e. timing and extent of catch basin screening implementation and the level of maintenance to be provided).

In addressing OC's comment, a brief evaluation on the hybrid option was conducted to estimate the capacity of the vortex separators that would be required and the additional costs associated with implementation of the vortex separators. It was estimated that the scale and cost of the vortex separator facility near the beach would be similar to Alternatives 2 and 3 described above. If the facility were to be located near the City boundary with the City of Los Angeles near Brentwood, the size of the facility could be reduced by approximately 40%. Due to high capital cost and City's belief that other stakeholders may choose their own compliance methods, further evaluation of the hybrid solution was discontinued.

Other agencies regulated by the Los Angeles Regional Water Quality Control Board (LARWQCB) have developed approaches and implementation plans for trash TMDLs. The County of Los Angeles, as one such agency, has developed an approach that the LARWQCB has certified to achieve full capture for trash removal. This approach, as defined in Resolution No. 04-023, contains criteria for a full capture trash removal system that are summarized below:

- ▼ The system shall trap particles retained by a 5mm mesh.
- ▼ Sizing is based on a one year frequency, one hour rainfall event.
- ▼ Rational method hydrology is utilized for determining the peak flow rate.

The LARWQCB has accepted a Connector Pipe System (a vertical stainless steel screen with 5mm openings inside a catch basin in such a manner that all water entering the basin must pass through the device) as an approved full capture system for the County's needs. Some concern exists relating to the screens blinding within these systems, thereby limiting hydraulic capacity at the catch basin, and creating flood control challenges upstream.

Early in the design phase of the City's Trash BMP Program, it is recommended that examples of approved practices within the region are assessed carefully and balanced with maintenance practices and flood control objectives of the City. This initial determination and any refined criteria specific to the City's Program should be reviewed with the LARWQCB prior to commencing design of the catch basin inserts. As noted above, this evaluation utilizes a Bio-Clean system to derive a unit cost for the catch basin insert/filter system. It is believed this system serves as a conservative unit cost for this comparison. During the design phase this system, as well as others, may be considered to meet the objectives of the City's Program.

### Reference Standard

The criteria for a full capture system, as described above, will be considered in design of the Trash BMPs.

CASQA BMP Fact Sheets MP-52 will also be utilized as guideline.

### Suggested Products and Suppliers

Bio Clean Environmental Services, Inc. <http://www.biocleanenvironmental.com/products/>  
Flogard by Kristar. <http://www.kristar.com/>



## **2.11 Downspout Redirect Program**

### Project Description

The City currently administers the Downspout Redirect Rebate Program. Up to \$40 of rebates per qualified downspout are available for the cost (material and labor) of redirecting rain gutter downspouts to permeable surfaces, such as landscaped areas. Additional information could be found at the City's website:

<http://www.smgov.net/Departments/OSE/categories/content.aspx?id=3847>.

### Reference Standard

DS Redirect Instructions.

[http://www.smgov.net/uploadedFiles/Departments/OSE/Categories/Urban\\_Runoff/Downspout\\_Redirect\\_HowTo.pdf](http://www.smgov.net/uploadedFiles/Departments/OSE/Categories/Urban_Runoff/Downspout_Redirect_HowTo.pdf).

### Costs

An annual budget of \$4,000/year plus an escalation rate of 3% per year is allocated in the Measure V 5-Year Plan to support this program.



## **2.12 Rain Barrel Program**

### Project Description

The City currently administers the Rain Barrel Rebate Program for storage of rainwater. Rebates up to \$250 per barrel (limited up to 499 gallons) are available for the cost of design, labor and materials. Additional information could be found at the City's website:

<http://www.smgov.net/Departments/OSE/categories/content.aspx?id=3847>.

### Reference Standard

Rain Barrel Installations & Maintenance

[http://www.smgov.net/uploadedFiles/Departments/OSE/Categories/Urban\\_Runoff/Install\\_Maintain\\_RainBarrel.pdf](http://www.smgov.net/uploadedFiles/Departments/OSE/Categories/Urban_Runoff/Install_Maintain_RainBarrel.pdf)

City's List of Suppliers

[http://www.smgov.net/uploadedFiles/Departments/OSE/Categories/Urban\\_Runoff/Barrel\\_Cistern\\_Supplierslist%204-22.pdf](http://www.smgov.net/uploadedFiles/Departments/OSE/Categories/Urban_Runoff/Barrel_Cistern_Supplierslist%204-22.pdf)

### Costs

An annual budget of \$12,000/year plus an escalation rate of 3% per year is allocated in the Measure V 5-Year Plan to support this program.





## **2.13 Cistern Program**

### Project Description

The City currently administers the Cistern Rebate Program for storage of rainwater. The City may increase the rebate amount from \$250-\$500 (per the existing program) to \$800 to help cover installation costs, which include electrical, plumbing, backflow prevention devices, and permitting costs for pressurized system. The rebates are limited to cisterns over 500 gallons each. Additional information could be found at the City's website:

<http://www.smgov.net/Departments/OSE/categories/content.aspx?id=3847>.

### Reference Standard

Rain Barrel Installations & Maintenance

[http://www.smgov.net/uploadedFiles/Departments/OSE/Categories/Urban\\_Runoff/Install\\_Maintain\\_RainBarrel.pdf](http://www.smgov.net/uploadedFiles/Departments/OSE/Categories/Urban_Runoff/Install_Maintain_RainBarrel.pdf)

### Costs

An annual budget of \$50,000/year plus an escalation rate of 3% per year is allocated in the Measure V 5-Year Plan to support this program.



### **3.0 SUMMARY OF THE 5-YEAR CAPITAL IMPROVEMENT PLAN**

Table 3-1 presents a summary of the proposed Measure V 5-Year Capital Improvement Plan.

A schedule of project implementation is presented in Table 3-2.

A schedule of expenditure for capital costs, O&M costs, and the total project was also developed based on the proposed Measure V 5-Year Capital Improvement Plan and is presented in Table 3-3, 3-4, and 3-5, respectively. The costs presented in Table 3-5 are total project costs, including construction, engineering, construction management, burdened salary for the City's Watershed Program Manager, administrative expenses, and O&M costs. It is estimated that the annual expenditure for Measure V in the next 5 years will range from \$1.3M to \$4.1M, totaling \$13.7M.

A summary of drainage area treated, reduction of runoff resulting from the Measure V 5-Year Capital Improvement Plan, and capital cost per drainage area treated for the proposed projects is provided in Appendix H.



**Table 3-1: Guidance List of Best Management Practices and Low Impact Development Strategies  
Summary of Measure V - 5-Year Capital Improvement Plan**



Project ID No.	Project Type/Category	Project Summary & Notes	Selection Criteria	Guideline Cost to Measure V	Cost for 5-year Program	Timing
1	Permeable Surface Alleys	As part of routine alley replacement program, center swales will be replaced with permeable surface, such as pervious concrete, to demonstrate the effective use of permeable products on the market. 3-5 locations will be selected per year for this type of improvement. Measure V will fund the incremental cost between the regular concrete and pervious concrete or equivalent.	Alley replacement required as part of a CIP project	\$70,000/year*	\$350,000*	Annual
2	Permeable Surface Street Gutters/Intersections	As part of routine street improvement program, concrete cross-gutters and intersections will be replaced with pervious surface, such as pervious concrete, to demonstrate the effective use of different permeable products on the market. Measure V will only fund the the incremental cost between the regular concrete and pervious concrete or equivalent.	Street gutter/intersection improvement in low traffic areas required as part of a CIP project	\$70,000/year*	\$350,000*	Annual
3	Miniature Parkway/Sidewalk Biofilters	Where nuisance or dry season flow exists, demonstration-scale wetlands, tree wells, and other bioretention features will be installed to capture and utilize the runoff. A custom-designed system or a packaged system may be utilized. Larger applications favor custom-designed systems.	Custom design or optimum available products on the market	\$100,000/year*	\$500,000*	Annual
4	Street Curb Extensions	In this application, the street curb is extended at the downstream end of streets to install wider depressed landscaping to capture and retain runoff; these extensions will include climate-appropriate plants and drip irrigation. Installation of a cistern will be considered where suitable to supply water for on-site landscaping. Runoff would be captured in one location rather than distributed along the street.	Wide streets with high runoff rate	\$100,000/year	\$500,000*	Annual
5	Green Streets	Ocean Park Blvd. Green Street Project (construction will start in 2011) will include implementation of various LID features, such as permeable gutters, sub-surface infiltration, permeable parking lanes, depressed parkways with drip irrigation and climate-appropriate plants, curb extensions, and depressed planters to capture runoff. If implementation of the Ocean Park Blvd. Green Street Project is found infeasible due to funding or other issues, retrofits at Los Amigos Park and Parking Lot 9A or 11 will be considered as an alternate project.	Wide streets with high runoff rate, target areas to infiltrate	\$1M* for Ocean Park Blvd. Green Street Project (or Retrofits at Los Amigos Park)	\$1,000,000*	FY 2010-11
6	Permeable Surface Parking Lots	As part of City's overall facility program, permeable surfaces, such as porous asphalt, will be utilized for retrofit or new city parking facilities to demonstrate the effective use of different permeable products on the market. Depressed planters will also be implemented to capture runoff. Measure V will cover the portion of the project cost that is associated with the stormwater quality enhancement (i.e. depressed planters and incremental cost between the regular asphalt and porous asphalt).	City parking lots due for improvements, planned new parking lots, or parking lots with drainage issues	See Project Descriptions for cost detail for resurfacing and installing depressed planters in Parking Lots 9, 9A, 11, and 26	See Table 3-5, Schedule of Expenditures	FY 2011-12
7	Park Retrofits	As part of these projects, wet weather runoff from a main storm drain will be diverted to an adjacent park for treatment (pretreatment and disinfection), storage, and use as irrigation water within the park. A replicable model will be developed and used throughout the City.	Parks near regional storm drain	As planned	See Table 3-5, Schedule of Expenditures	Ozone Park: FY 2010-11 Marine Park: FY 2011-12 Memorial Park: FY 2012-13 Clover Park, Virginia Ave. Park, and Reed Park: Post-2015 Los Amigos Park: (in-lieu of Item 5)
8	Deep Infiltration In-Line Storm Drain Pilot Project	A pilot-scale aquifer recharge system will be considered to infiltrate dry and wet weather runoff from a storm drain via deep infiltration wells. Geologic reconnaissance will be performed to assess feasibility of such project and to develop concept.	Strategic locations to be selected based on results of geologic reconnaissance	\$100,000* for initial geologic reconnaissance and concept development	\$100,000*	FY 2010-11
9	Payment on J-2/J-3 Agreement with City of L.A.	Payment for the Draft Memorandum of Agreement (MOA) with City of L.A. for the Santa Monica Bay Beaches Wet Weather Bacteria TMDL Implementation Plan Projects Cost Sharing Jurisdictional Groups Two And Three. Assumes payment of \$4M over 20-year term.	See MOA	\$200,000/year plus interest rate of 3.25% per year	See Table 3-5, Schedule of Expenditures	Annual
10	Trash BMPs	In order to achieve compliance with a Santa Monica Bay trash TMDL, trash BMPs, such as vortex separators or inlet filter/inserts, will be installed to reduce the amount of trash entering the Bay upon storm events.	See Table 2.10-2, Pico-Kenter Watershed Treatment Alternatives	As shown in Phase 1	See Table 3-5, Schedule of Expenditures	See Project Description
11	Downspout Redirect Program	Offer \$40 rebate for parts/installation per DS		\$4,000/year*	\$20,000*	Annual
12	Rain Barrel Program	Offer \$250 rebate up to 499 gallon barrel		\$12,000/year*	\$60,000*	Annual
13	Cistern Program	May increase the rebate amount from \$250-\$500 (per the existing program) to \$800 to help cover installation costs, which include electrical, plumbing, backflow prevention devices, and permitting costs for pressurized system. This applies to system of 500 gallons or more.		\$50,000/year*	\$250,000*	Annual

\*Initial budgets without escalation, burdened salary for City's Watershed Program Manager, or administrative expenses considered.



**Table 3-2: Implementation Schedule of BMP Practices and LID Strategies  
 Measure V 5-Year Capital Improvement Plan**

Project ID No.	Project Type/Category	FY 2010 - 2011	FY 2011 - 2012	FY 2012 - 2013	FY 2013 - 2014	FY 2014 - 2015
1	Permeable Surface Alleys					
2	Permeable Surface Street Gutters/Intersections					
3	Miniature Parkway/Sidewalk Biofilters					
4	Street Curb Extensions					
5	Green Streets					
6	Permeable Surface Parking Lots					
7	Park Retrofits					
	- Ozone Park					
	- Marine Park					
	- Memorial Park					
8	Deep Infiltration In-Line Storm Drain Pilot Project					
9	Payment on J-2/J-3 Agreement with City of L.A.					
10	Trash BMPs					
11	Downspout Redirect Program					
12	Rain Barrel Program					
13	Cistern Program					





**Table 3-3: Schedule of Expenditures for Best Management Practices and Low Impact Development Strategies  
 Measure V 5-Year Capital Improvement Plan – Capital Costs\***

Project ID No.	Project Type/Category	FY 2010 - 2011	FY 2011 - 2012	FY 2012 - 2013	FY 2013 - 2014	FY 2014 - 2015	Totals
1	Permeable Surface Alleys	\$71,786	\$70,986	\$67,395	\$74,181	\$83,559	\$367,907
2	Permeable Surface Street Gutters/Intersections	\$71,786	\$70,986	\$67,395	\$74,181	\$83,559	\$367,907
3	Miniature Parkway/Sidewalk Biofilters	\$95,430	\$87,776	\$77,598	\$79,496	\$83,315	\$423,615
4	Street Curb Extensions	\$96,023	\$90,507	\$83,421	\$90,518	\$101,937	\$462,405
5	Green Streets	\$741,206	\$324,159	\$0	\$0	\$0	\$1,065,365
6	Permeable Surface Parking Lots	\$0	\$216,439	\$0	\$0	\$0	\$216,439
7	Park Retrofits						
	- Ozone Park	\$894,742	\$0	\$0	\$0	\$0	\$894,742
	- Marine Park	\$211,773	\$676,411	\$211,938	\$0	\$0	\$1,100,122
	- Memorial Park	\$0	\$540,265	\$2,903,548	\$602,113	\$0	\$4,045,925
8	Deep Infiltration In-Line Storm Drain Pilot Project	\$109,063	\$0	\$0	\$0	\$0	\$109,063
9	Payment on J-2/J-3 Agreement with City of L.A.	\$218,656	\$230,381	\$233,281	\$273,715	\$329,019	\$1,285,051
10	Trash BMPs	\$845,217	\$428,039	\$106,820	\$109,760	\$112,700	\$1,602,536
11	Downspout (DS) Redirect Program	\$4,363	\$4,585	\$4,632	\$5,421	\$6,501	\$25,502
12	Rain Barrel Program	\$13,088	\$13,756	\$13,895	\$16,264	\$19,503	\$76,507
13	Cistern Program	\$54,532	\$57,317	\$57,898	\$67,768	\$81,264	\$318,778
	<b>Totals</b>	<b>\$3,427,665</b>	<b>\$2,811,606</b>	<b>\$3,827,820</b>	<b>\$1,393,418</b>	<b>\$901,356</b>	<b>\$12,361,865</b>

\*Includes escalation at 3% per year, burdened salary for City's Watershed Program Manager, and administrative expenses. Also includes program administrative cost of \$98,000/year escalated at 3% per year for implementation of Trash BMPs.





**Table 3-4: Schedule of Expenditures for Best Management Practices and Low Impact Development Strategies  
 Measure V 5-Year Capital Improvement Plan – O&M Costs\***

Project ID No.	Project Type/Category	FY 2010 - 2011	FY 2011 - 2012	FY 2012 - 2013	FY 2013 - 2014	FY 2014 - 2015	Totals
1	Permeable Surface Alleys	\$4,304	\$8,605	\$12,901	\$17,199	\$21,499	\$64,509
2	Permeable Surface Street Gutters/Intersections	\$4,304	\$8,605	\$12,901	\$17,199	\$21,499	\$64,509
3	Miniature Parkway/Sidewalk Biofilters	\$12,875	\$24,866	\$36,073	\$46,586	\$56,473	\$176,873
4	Street Curb Extensions	\$12,315	\$22,338	\$30,578	\$37,433	\$43,190	\$145,855
5	Green Streets	\$0	\$22,279	\$22,947	\$23,636	\$24,345	\$93,207
6	Permeable Surface Parking Lots	\$0	\$38,911	\$40,079	\$41,281	\$42,519	\$162,790
7	Park Retrofits						
	- Ozone Park	\$0	\$21,200	\$21,800	\$22,400	\$23,000	\$88,400
	- Marine Park	\$0	\$0	\$21,800	\$22,400	\$23,000	\$67,200
	- Memorial Park	\$0	\$0	\$0	\$28,000	\$28,750	\$56,750
8	Deep Infiltration In-Line Storm Drain Pilot Project	\$0	\$0	\$0	\$0	\$0	\$0
9	Payment on J-2/J-3 Agreement with City of L.A.	\$0	\$0	\$0	\$0	\$0	\$0
10	Trash BMPs	\$0	\$99,004	\$101,806	\$104,608	\$107,410	\$412,828
11	Downspout (DS) Redirect Program	\$0	\$0	\$0	\$0	\$0	\$0
12	Rain Barrel Program	\$0	\$0	\$0	\$0	\$0	\$0
13	Cistern Program	\$0	\$0	\$0	\$0	\$0	\$0
	<b>Totals</b>	<b>\$33,799</b>	<b>\$245,808</b>	<b>\$300,885</b>	<b>\$360,742</b>	<b>\$391,686</b>	<b>\$1,332,920</b>

\* Includes escalation at 3% per year.





**Table 3-5: Schedule of Expenditures for Best Management Practices and Low Impact Development Strategies  
 Measure V 5-Year Capital Improvement Plan – Total Project Costs**

Project ID No.	Project Type/Category	FY 2010 - 2011	FY 2011 - 2012	FY 2012 - 2013	FY 2013 - 2014	FY 2014 - 2015	Totals
1	Permeable Surface Alleys*	\$76,091	\$79,590	\$80,296	\$91,380	\$105,058	<b>\$432,416</b>
2	Permeable Surface Street Gutters/Intersections*	\$76,091	\$79,590	\$80,296	\$91,380	\$105,058	<b>\$432,416</b>
3	Miniature Parkway/Sidewalk Biofilters*	\$108,305	\$112,642	\$113,671	\$126,082	\$139,788	<b>\$600,488</b>
4	Street Curb Extensions*	\$108,338	\$112,845	\$113,999	\$127,951	\$145,127	<b>\$608,261</b>
5	Green Streets*	\$741,206	\$346,438	\$22,947	\$23,636	\$24,345	<b>\$1,158,572</b>
6	Permeable Surface Parking Lots	\$0	\$255,351	\$40,079	\$41,281	\$42,519	<b>\$379,229</b>
7	Park Retrofits						
	- Ozone Park	\$894,742	\$21,200	\$21,800	\$22,400	\$23,000	<b>\$983,142</b>
	- Marine Park	\$211,773	\$676,411	\$233,738	\$22,400	\$23,000	<b>\$1,167,322</b>
	- Memorial Park	\$0	\$540,265	\$2,903,548	\$630,113	\$28,750	<b>\$4,102,675</b>
8	Deep Infiltration In-Line Storm Drain Pilot Project*	\$109,063	\$0	\$0	\$0	\$0	<b>\$109,063</b>
9	Payment on J-2/J-3 Agreement with City of L.A.	\$218,656	\$230,381	\$233,281	\$273,715	\$329,019	<b>\$1,285,051</b>
10	Trash BMPs	\$845,217	\$527,043	\$208,626	\$214,368	\$220,110	<b>\$2,015,364</b>
11	Downspout (DS) Redirect Program*	\$4,363	\$4,585	\$4,632	\$5,421	\$6,501	<b>\$25,502</b>
12	Rain Barrel Program*	\$13,088	\$13,756	\$13,895	\$16,264	\$19,503	<b>\$76,507</b>
13	Cistern Program*	\$54,532	\$57,317	\$57,898	\$67,768	\$81,264	<b>\$318,778</b>
	<b>Totals</b>	<b>\$3,461,464</b>	<b>\$3,057,414</b>	<b>\$4,128,705</b>	<b>\$1,754,159</b>	<b>\$1,293,042</b>	<b>\$13,694,785</b>

\*Costs include escalation at 3% per year, burdened salary for City's Watershed Program Manager, and administrative expenses in addition to the initial budgets that are shown in Table 3-1.





## 4.0 REFERENCES

Major references for this 5-Year Capital Improvement Plan are listed below.

*Amendment to the Water Quality Control Plan for the Los Angeles Region to Amend the Total Maximum Daily Load for Trash in the Ballona Creek and Wetland, Los Angeles RWQCB Resolution No. 04-023, March 4, 2004*

*Certification of the Connector Pipe Screen Device as a Full Capture System for Trash Removal under the Ballona Creek and the Los Angeles River Trash Total Maximum Daily Loads, Los Angeles RWQCB, August 1, 2007*

*City of Santa Monica Hydrology Study (Volumes A & B), Berryman & Henigar, Inc., July 1998*

*City of Santa Monica Watershed Management Plan, Brown and Caldwell, April 2006*

*Draft Memorandum of Agreement, Santa Monica Bay Beaches Wet Weather Bacterial TMDL Implementation Plan Projects Cost Sharing Jurisdictional Groups Two and Three, August 16, 2007.*

*Investigation of Reported Beach Ponding Downstream of the Pier Storm Drain Diversion and Recommended Mitigation Measure, PSOMAS, October 2007*

*LID Cost Tool, WERF, May 2009*

*RS Means Heavy Construction Cost Data, 2007*

*Operational Assessment of the Santa Monica Urban Runoff Recycling Facility – Five Years Later, PSOMAS, March 2007*

*Pico-Kenter Storm Drain Upgrades Final Concept Report, Black & Veatch, April 2009*

*Santa Monica Bay Beaches Bacterial TMDL J2/3 Implementation Plan (PowerPoint Presentation), City of Los Angeles, Santa Monica, El Segundo, County of Los Angeles, and Caltrans, August 2008*

*Statement of support for the efforts of responsible jurisdictions and agencies in Jurisdictional Groups 2 and 3 to utilize an integrated water resources approach to achieve full compliance with the Santa Monica Bay Beaches Bacteria Wet Weather TMDL in the shortest possible timeframe and no later than 2021, Los Angeles RWQCB Resolution No. 2006-006, April 6, 2006*





## **APPENDIX A: List of Alleys**

**ZONE #1 FY2009-10 NORTH OF MONTANA**

YES/NO 2' GUTTER FIELD	SHORTDESC	CIP ZONE	ADD ALLEY_ID	LENGTH	WIDTH	AREA	DATE	INSP
yes	10th CT 502	1	5449	599	20	11980	2/27/2008	TB
yes	12th CT 302	1	5466	550	20	11000	1/18/2008	TW
yes	12th CT 502	1	5493	600	20	12000	1/18/2008	TW
yes	12th CT 602	1	5370	816	20	16320	1/18/2008	TW
yes	15th CT 502	1	5504	656	20	13120	1/19/2008	TW
yes	22nd CT 302	1	5901	794	20	15880	2/29/2008	TB
yes	9th CT 302	1	5433	347	20	6940	2/2/2008	RJ
yes	9th CT 402	1	5419	550	20	11000	2/2/2008	RJ
yes	9th CT 602	1	5374	816	20	16320	2/2/2008	RJ
yes	ALTA PL N 402	1	5378	1131	20	22620	2/2/2008	RJ
yes	EUCLID CT 302	1	5480	550	20	11000	2/9/2008	RJ
yes	SAN VICENTE PL N 124	1	5385	536	20	10720	2/29/2008	RJ
yes	SAN VICENTE PL N 340	1	5382	549	20	10980	2/29/2008	RJ
yes	SAN VICENTE PL N 402	1	5356	1356	20	27120	2/29/2008	RJ
yes	SAN VICENTE PL S 274	1	5911	137	20	2740	2/29/2008	RJ
	<b>ZONE #1</b>	<b>15</b>		<b>9,987</b>		<b>199,740</b>		

**ZONE #2 FY2010-11 MONTANA TO WILSHIRE**

YES/NO 2' GUTTER FIELD	SHORTDESC	CIP ZONE	ADD ALLEY_ID	LENGTH	WIDTH	AREA	DATE	INSP
yes	12th CT 1002	2	5750	600	20	12000	1/18/2008	TW
yes	12th CT 902	2	5716	601	20	12020	1/18/2008	TW
yes	15th CT 1102	2	5758	600	20	12040	1/19/2008	TW
yes	16th CT 902	2	5960	600	20	12000	2/29/2008	RJ
yes	21st CT 1162	2	6007	451	20	9020	2/29/2008	TB
yes	4th CT 902	2	5550	601	20	12020	2/1/2008	RJ
no	5th CT 902	2	6569	148	15	2220	2/1/2008	RJ
yes	6th CT 1002	2	5672	602	20	12040	2/1/2008	RJ
yes	6th CT 802	2	5633	599	20	11980	2/1/2008	RJ
yes	6th CT 902	2	5643	600	20	12000	2/1/2008	RJ
yes	7th CT 802	2	5634	600	20	12000	2/2/2008	RJ
yes	9th CT 902	2	5660	600	20	12000	2/2/2008	RJ
no	CHELSEA CT 1001	2	6136	371	15	5565	2/9/2008	RJ
yes	LINCOLN CT 802	2	5651	600	20	12000	2/15/2008	RJ
yes	LINCOLN CT 902	2	5657	599	20	11980	2/15/2008	RJ
yes	STANFORD CT 823	2	6280	1326	20	26520	2/29/2008	RJ
yes	STANFORD CT 824	2	6307	50	20	1000	2/29/2008	RJ
	<b>ZONE #2</b>	<b>17</b>		<b>9,548</b>		<b>188,405</b>		

**ZONE #3 FY2011-12 WILSHIRE TO PICO east of 26th St**

YES/NO 2' GUTTER FIELD	SHORTDESC	CIP ZONE	ADD ALLEY_ID	LENGTH	WIDTH	AREA	DATE	INSP
no	ARIZONA PL S 2634	3	6261	340	15	5100	2/2/2008	RJ
no	BERKELEY CT 1301	3	6382	436	16	6976	2/9/2008	RJ
no	BERKELEY CT 1701	3	7086	610	16	9760	2/9/2008	RJ
no	COLORADO PL S 3002	3	6448	290	16	4640	2/9/2008	RJ
no	FRANKLIN CT 1201	3	6462	296	16	4736	2/9/2008	RJ
no	FRANKLIN CT 1259	3	6387	158	16	2528	2/9/2008	RJ
no	FRANKLIN CT 1701	3	7087	610	17	10370	2/9/2008	RJ
yes	PICO PL N 3002	3	7128	902	20	18040	2/23/2008	RJ
no	SANTA MONICA PL S 2702	3	6369	311	15	4665	2/29/2008	RJ
no	SANTA MONICA PL S 2902	3	6347	340	15	5100	2/29/2008	RJ
no	SANTA MONICA PL S 3002	3	6402	340	15	5100	2/29/2008	RJ
no	SANTA MONICA PL S 3102	3	6395	340	15	5100	2/29/2008	RJ
no	STANFORD CT 1401	3	6342	426	15	6390	2/29/2008	RJ
no	STANFORD CT 1501	3	6433	440	15	6600	2/29/2008	RJ
no	STANFORD CT 1601	3	6449	475	15	7125	2/29/2008	RJ
no	WILSHIRE PL S 3202	3	6341	328	16	5248	2/29/2008	TB
no	YALE CT 1501	3	6421	440	17	7480	2/29/2008	TB
	<b>ZONE #3</b>	<b>17</b>		<b>7,082</b>		<b>114,958</b>		

**ZONE #4 FY2012-13 WILSHIRE TO PICO west of 26th St**

YES/NO 2' GUTTER FIELD	SHORTDESC	CIP ZONE	ADD ALLEY_ID	LENGTH	WIDTH	AREA	DATE	INSP
yes	14th CT 1202	4	5616	601	20	12020	1/18/2008	TW
yes	14th CT 1402	4	5832	601	20	12020	1/19/2008	TW
yes	17th CT 1502	4	6202	600	20	12000	2/29/2008	RJ
yes	19th CT 1402	4	6176	600	20	12000	2/29/2008	RJ
yes	20th CT 1501	4	6218	274	20	5480	2/29/2008	TB
no	24th CT 1202	4	6235	441	16	7056	2/9/2008	TW
yes	9th CT 1302	4	5794	600	20	12000	2/2/2008	RJ
yes	BROADWAY PL S 2001	4	6214	121	20	2420	2/9/2008	RJ
no	CALIFORNIA PL S 2502	4	6154	280	15	4200	2/9/2008	RJ
no	CHELSEA CT 1202	4	6249	442	15	6630	2/9/2008	RJ
yes	EUCLID CT 1202	4	5618	600	20	12000	2/9/2008	RJ
yes	EUCLID CT 1802	4	6603	1156	20	23120	2/9/2008	RJ
yes	LINCOLN CT 1202	4	5622	600	20	12000	2/15/2008	RJ
yes	LINCOLN CT 1402	4	5776	601	20	12020	2/15/2008	RJ
no	OLYMPIC PL S 18	4	5605	185	17	3145	2/23/2008	RJ
	<b>ZONE #4</b>	<b>15</b>		<b>7,702</b>		<b>148,111</b>		

**ZONE #5 FY2013-14 SOUTH OF PICO**

YES/NO 2' GUTTER FIELD	SHORTDESC	CIP ZONE	ADD ALLEY_ID	LENGTH	WIDTH	AREA	DATE	INSP
yes	11th CT 2701	5	6753	300	20	6000	1/18/2008	TW
yes	24th CT 2206	5	6834	837	20	16740	2/9/2008	TW
yes	5th CT 2648	5	5640	600	20	12000	2/1/2008	RJ
yes	ASHLAND PL N 1802	5	6951	500	20	10000	2/2/2008	RJ
no	HILL PL N 402	5	6528	160	17	3200	2/15/2008	RJ
yes	HILL PL N 804	5	6733	787	20	15740	2/15/2008	RJ
no	MAPLE PL N 1002	5	6680	501	17	8517	2/23/2008	RJ
yes	OCEAN PARK PL N 1702	5	6956	417	20	8340	2/23/2008	RJ
yes	PEARL PL S 2532	5	7055	168	20	3360	2/23/2008	RJ
yes	PICO PL S 2502	5	6832	316	20	6320	2/23/2008	RJ
no	PINE PL N 1002	5	6658	500	16	8000	2/29/2008	RJ
	<b>ZONE #5</b>	<b>11</b>		<b>5,086</b>		<b>98,217</b>		



## **APPENDIX B: Map of City Zones for Street Improvement Program & Locations of Existing Pervious Concrete Gutters**

---

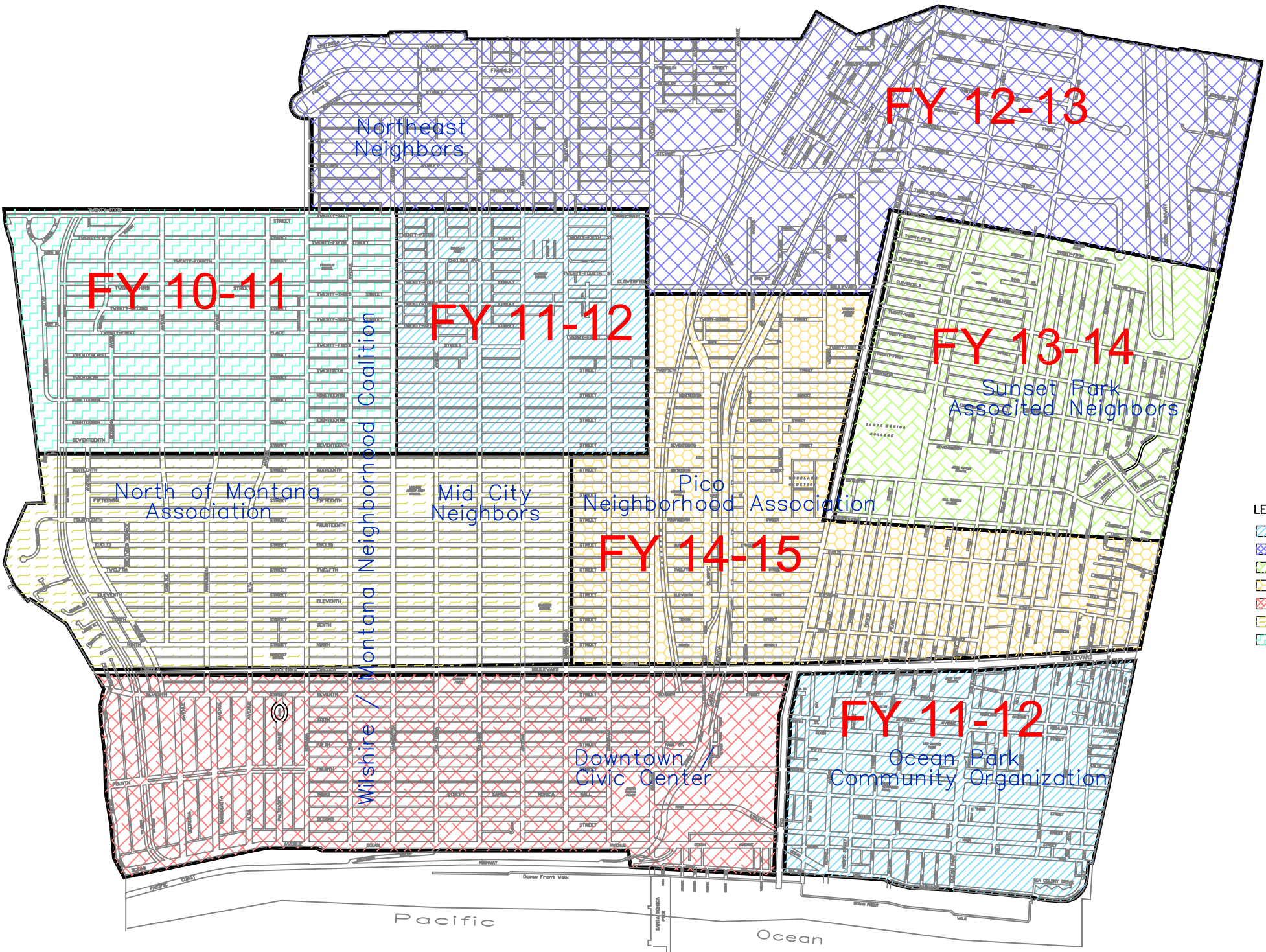

FY 12-13

Northeast Neighbors

FY 13-14

Sunset Park Associated Neighbors

FY 11-12

Mid City Neighbors  
Pico Neighborhood Association

FY 14-15

FY 11-12

Ocean Park Community Organization

FY 10-11

North of Montana Association

Wishire / Montana Neighborhood Coalition

Downtown / Civic Center

- LEGEND:
- ZONE 1
  - ZONE 2
  - ZONE 3
  - ZONE 4
  - ZONE 5
  - ZONE 6
  - ZONE 7

Pacific

Ocean

# Locations of Pervious Concrete Gutters

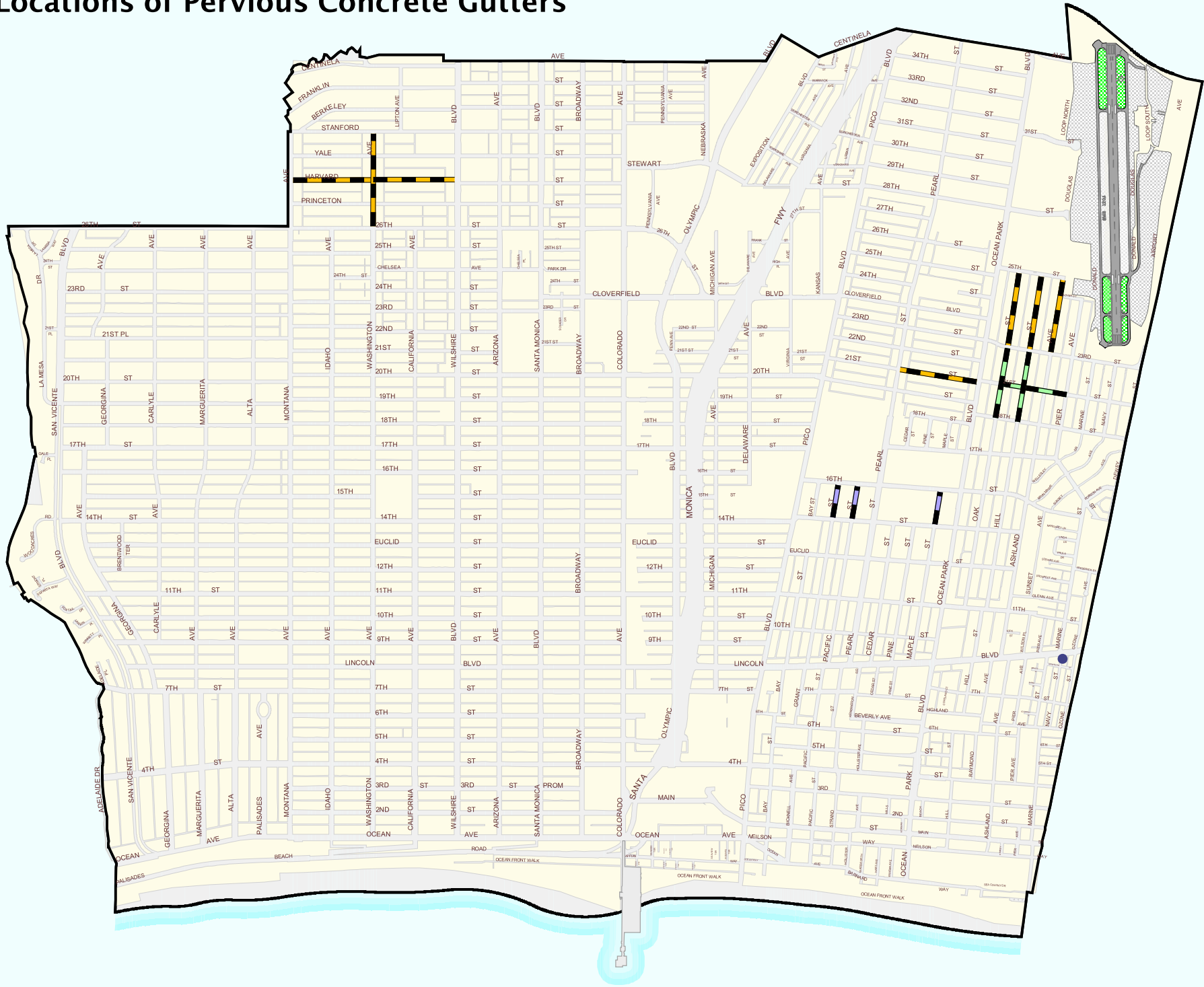



## **APPENDIX C: Map of Ocean Park Boulevard Project Area**



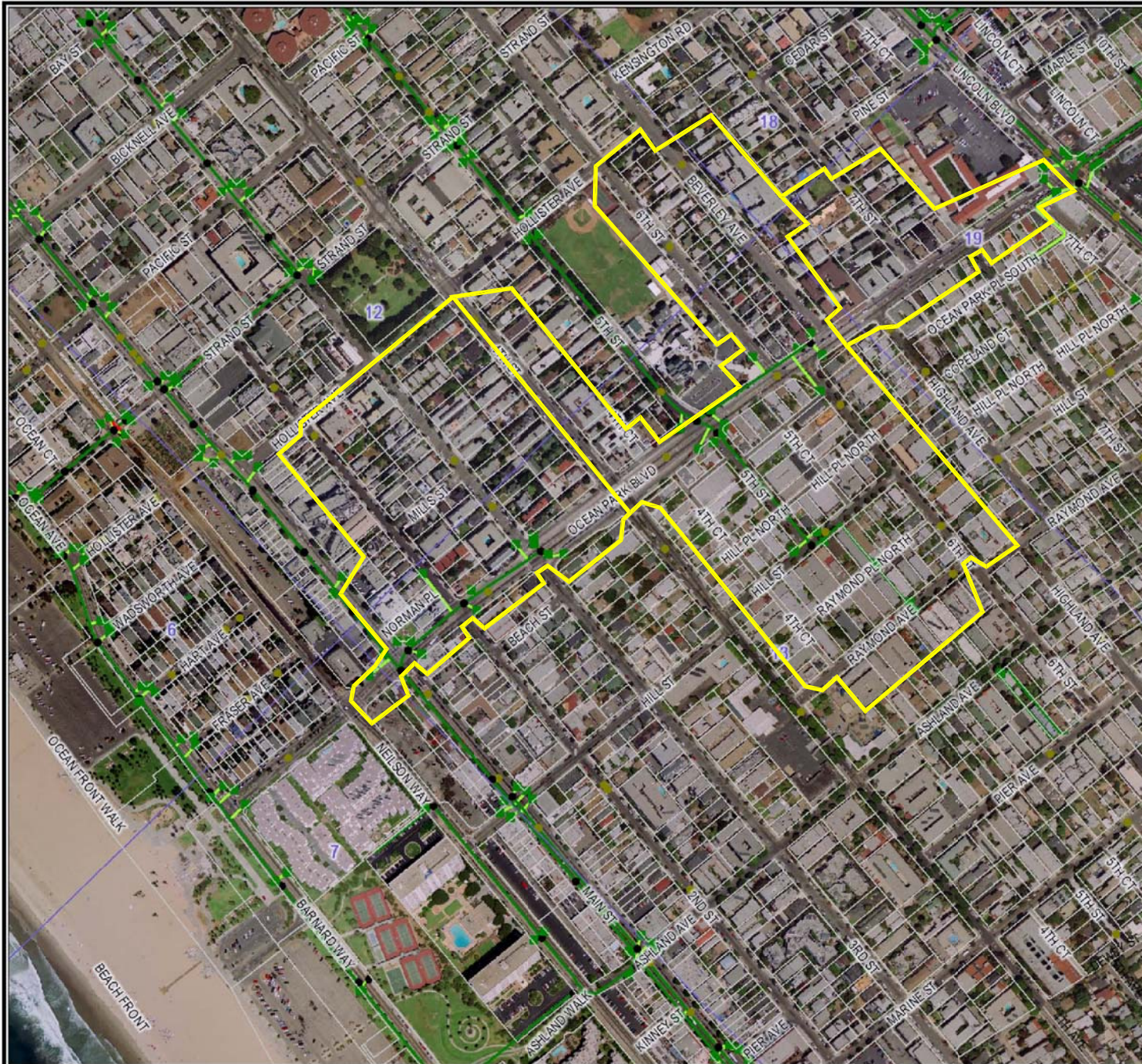

-  Parcel
-  Utility Grid System
-  Storm Catch Basin
-  Storm Maintenance Hole
-  Storm Outlet
-  Storm Transition Box
-  Continuous Deflective System
-  BMP
-  Storm Drain
-  Active
-  Abandoned
-  Future
-  Storm Lateral
- Orthophoto (3in, Aug 2000)



# OP BI Drainage

Scale 1:5,937  
 City of Santa Monica GIS  
 Printed: Feb 11, 2009 9:41:56 AM





## **APPENDIX D: Estimated Turf Irrigation Requirements in Santa Monica**

---



### Average Monthly Turf Irrigation Requirements in Santa Monica, CA

Station ID: 99  
Station Name: Santa Monica  
Region: Los Angeles Basin

$ET_c = K_c \times ET_o$

Month	Jan	Feb	Mar	Apr	May	Jun	Jul	Aug	Sep	Oct	Nov	Dec	Total
Monthly Average $ET_o$ (inches)	1.79	2.12	3.3	4.49	4.73	5.03	5.4	5.38	3.94	3.4	2.42	2.22	44.22
Monthly Average $ET_c$ (inches)	1.25	1.48	2.31	3.14	3.31	3.52	3.78	3.77	2.76	2.38	1.69	1.55	30.95

$K_c = 0.7$  for turfgrass (an average of cool and warm season species)

- \*Monthly average  $ET_o$  was calculated based on a long-term average of monthly  $ET_o$  data since December 1992.
- \*Data source: California Irrigation Management Information System (CIMIS) <http://www.cimis.water.ca.gov>
- \* $ET_o$ : Reference Evapotranspiration
- \* $ET_c$ : Crop Evapotranspiration
- \* $K_c$ : Crop Coefficient

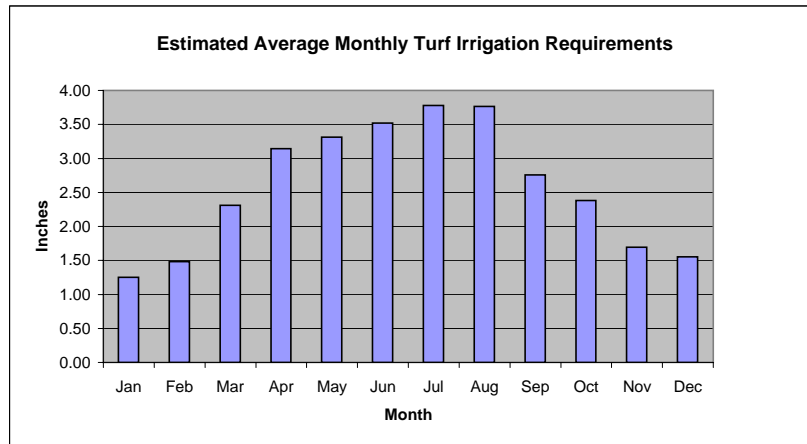

Wet season (Oct - Mar Monthly Average) = 1.78 inches/month  
 Dry season (Apr - Jun Monthly Average) = 3.38 inches/month



# **APPENDIX E: Park Retrofit Projects Conceptual Level Cost Opinions & Estimated Costs of Wet Season Harvesting Projects within the City of Santa Monica**

---

# Memorial Park Stormwater Harvesting (FY 2012-13)

## Conceptual Level Preliminary Construction Costs

<b>Design Items</b>	<b>Total Cost</b>
Conventionally-Reinforced Concrete Reservoir*	\$500,000
300 gpm Submersible Pump Station (From 15' Deep Storm Drain)	\$150,000
Irrigation Pumps	\$10,000
Hydrodynamic Separators (CDS®), Diversion Structures and Piping	\$735,000
Strainer/Disinfection (Allocation)	\$75,000
Site Piping (Allocation)	\$100,000
Irrigation System Improvements (Allocation)	\$25,000
Subtotal 1, Construction Costs	<u>\$1,595,000</u>
Mobilization (5%)	\$79,750
Permits (10%)	\$159,500
Allowances (5%)	<u>\$79,750</u>
Subtotal 2	\$1,914,000
Estimating Contingency (25%)	<u>\$478,500</u>
Subtotal 3	\$2,392,500
Escalation (3 yr, 3% per year)	<u>\$221,849</u>
Subtotal 4	\$2,614,349
Construction Contingency (10%)	\$261,435
<b>Construction Cost Total</b>	<b><u>\$2,875,784</u></b>

\*Earthwork and dewatering included.

## Conceptual Level Preliminary Total Project Costs

Construction Costs	\$2,876,000
Design (15% of Construction Costs)	\$432,000
Construction Management (15% of Construction Costs)	\$432,000
<b>Total Project Costs</b>	<b><u>\$3,740,000</u></b>

# Ozone Park Stormwater Harvesting (FY 2010-11)

## Conceptual Level Preliminary Construction Costs

<b>Design Items</b>	<b>Total Cost</b>
Conventionally-Reinforced Concrete Reservoir*	\$37,500
25 gpm Submersible Pump Station (Assume 15' Deep Storm Drain)	\$80,000
Irrigation Pumps	\$5,000
Hydrodynamic Separators (CDS®), Diversion Structures and Piping	\$237,850
Strainer/Disinfection (Allocation)	\$10,000
Site Piping (Allocation)	\$8,000
Irrigation System Improvements (Allocation)	\$3,000
Subtotal 1, Construction Costs	<hr/> \$381,350
Mobilization (5%)	\$19,068
Permits (10%)	\$38,135
Allowances (5%)	<hr/> \$19,068
Subtotal 2	\$457,620
Estimating Contingency (25%)	<hr/> \$114,405
Subtotal 3	\$572,025
Escalation (1 yr, 3% per year)	<hr/> \$17,161
Subtotal 4	\$589,186
Construction Contingency (10%)	\$58,919
<b>Construction Cost Total</b>	<hr/> <b>\$648,104</b>

\*Earthwork and dewatering included.

## Conceptual Level Preliminary Total Project Costs

Construction Costs	\$649,000
Design (15% of Construction Costs)	\$98,000
Construction Management (15% of Construction Costs)	\$98,000
<b>Total Project Costs</b>	<hr/> <b>\$845,000</b>

# Marine Park Retrofit (FY 2011-12)

## Conceptual Level Preliminary Construction Costs

<b>Design Items</b>	<b>Total Cost</b>
Irrigation Piping from Penmar and Other Improvements (Allocation)	\$450,000
Subtotal 1, Construction Costs	<u>\$450,000</u>
Mobilization (5%)	\$22,500
Permits (10%)	\$45,000
Allowances (5%)	<u>\$22,500</u>
Subtotal 2	<u>\$540,000</u>
Estimating Contingency (25%)	<u>\$135,000</u>
Subtotal 3	<u>\$675,000</u>
Escalation (2 yr, 3% per year)	<u>\$41,108</u>
Subtotal 4	<u>\$716,108</u>
Construction Contingency (10%)	\$71,611
<b>Construction Cost Total</b>	<b><u>\$787,718</u></b>

\*Earthwork and dewatering included.

## Conceptual Level Preliminary Total Project Costs

Construction Costs	\$788,000
Design (15% of Construction Costs)	\$119,000
Construction Management (15% of Construction Costs)	\$119,000
<b>Total Project Costs</b>	<b><u>\$1,026,000</u></b>

# Clover Park Stormwater Harvesting (Post-2015)

## Conceptual Level Preliminary Construction Costs

<b>Design Items</b>	<b>Total Cost</b>
Conventionally-Reinforced Concrete Reservoir*	\$1,000,000
400 gpm Submersible Pump Station (From 15' Deep Storm Drain)	\$175,000
Irrigation Pumps	\$15,000
Hydrodynamic Separators (CDS®), Diversion Structures and Piping	\$735,000
Strainer/Disinfection (Allocation)	\$75,000
Site Piping (Allocation)	\$120,000
Irrigation System Improvements (Allocation)	\$30,000
Subtotal 1, Construction Costs	<u>\$2,150,000</u>
Mobilization (5%)	\$107,500
Permits (10%)	\$215,000
Allowances (5%)	<u>\$107,500</u>
Subtotal 2	<u>\$2,580,000</u>
Estimating Contingency (25%)	<u>\$645,000</u>
Subtotal 3	<u>\$3,225,000</u>
Escalation (5 yr, 3% per year)	<u>\$513,659</u>
Subtotal 4	<u>\$3,738,659</u>
Construction Contingency (10%)	<u>\$373,866</u>
<b>Construction Cost Total</b>	<b><u>\$4,112,525</u></b>

\*Earthwork and dewatering included.

## Conceptual Level Preliminary Total Project Costs

Construction Costs	\$4,113,000
Design (15% of Construction Costs)	\$617,000
Construction Management (15% of Construction Costs)	\$617,000
<b>Total Project Costs</b>	<b><u>\$5,347,000</u></b>



# Reed Park Stormwater Harvesting (Post-2015)

## Conceptual Level Preliminary Construction Costs

<b>Design Items</b>	<b>Total Cost</b>
Conventionally-Reinforced Concrete Reservoir*	\$100,000
75 gpm Submersible Pump Station (Assume 15' Deep Storm Drain)	\$100,000
Irrigation Pumps	\$70,000
Hydrodynamic Separators (CDS®), Diversion Structures and Piping	\$332,850
Strainer/Disinfection (Allocation)	\$30,000
Site Piping (Allocation)	\$30,000
Irrigation System Improvements (Allocation)	\$6,000
Subtotal 1, Construction Costs	<u>\$668,850</u>
Mobilization (5%)	\$33,443
Permits (10%)	\$66,885
Allowances (5%)	<u>\$33,443</u>
Subtotal 2	\$802,620
Estimating Contingency (25%)	<u>\$200,655</u>
Subtotal 3	\$1,003,275
Escalation (5 yr, 3% per year)	<u>\$159,796</u>
Subtotal 4	\$1,163,071
Construction Contingency (10%)	\$116,307
<b>Construction Cost Total</b>	<b><u>\$1,279,378</u></b>

\*Earthwork and dewatering included.

## Conceptual Level Preliminary Total Project Costs

Construction Costs	\$1,280,000
Design (15% of Construction Costs)	\$192,000
Construction Management (15% of Construction Costs)	\$192,000
<b>Total Project Costs</b>	<b><u>\$1,664,000</u></b>

# Virginia Avenue Park Stormwater Harvesting (Post 2015)

## Conceptual Level Preliminary Construction Costs

<b>Design Items</b>	<b>Total Cost</b>
Conventionally-Reinforced Concrete Reservoir*	\$162,500
100 gpm Submersible Pump Station (Assume 15' Deep Storm Drain)	\$100,000
Irrigation Pumps	\$75,000
Hydrodynamic Separators (CDS®), Diversion Structures and Piping	\$347,850
Strainer/Disinfection (Allocation)	\$30,000
Site Piping (Allocation)	\$40,000
Irrigation System Improvements (Allocation)	\$8,000
Subtotal 1, Construction Costs	<u>\$763,350</u>
Mobilization (5%)	\$38,168
Permits (10%)	\$76,335
Allowances (5%)	<u>\$38,168</u>
Subtotal 2	\$916,020
Estimating Contingency (25%)	<u>\$229,005</u>
Subtotal 3	\$1,145,025
Escalation (5 yr, 3% per year)	<u>\$182,373</u>
Subtotal 4	\$1,327,398
Construction Contingency (10%)	\$132,740
<b>Construction Cost Total</b>	<b><u>\$1,460,138</u></b>

\*Earthwork and dewatering included.

## Conceptual Level Preliminary Total Project Costs

Construction Costs	\$1,461,000
Design (15% of Construction Costs)	\$220,000
Construction Management (15% of Construction Costs)	\$220,000
<b>Total Project Costs</b>	<b><u>\$1,901,000</u></b>

**Estimated Costs of Wet Season Harvesting Projects within the City of Santa Monica**

Park	Preliminary Storage Tank Size (gallons)	Estimated Capital Cost <sup>1</sup>	Estimated Annualized Cost @ 6%, 20 year (\$/year)	Estimated Annual O&M Cost	Estimated Annualized Total Project Cost (\$/year) <sup>3</sup>	Estimated Harvested Stormwater (gallons/year) <sup>3</sup>	Estimated Unit Cost of Harvested Stormwater (\$/ac-ft) <sup>4</sup>
Memorial Park	200,000	\$3,700,000	\$323,000	\$25,000	\$348,000	2,571,000	\$44,100
Ozone Park	15,000	\$845,000	\$74,000	\$20,000	\$94,000	193,000	\$158,700
Marine Park	Storage at Penmar	\$1,100,000	\$96,000	\$20,000	\$116,000	1,170,000	\$32,300
Virginia Avenue Park	65,000	\$1,900,000	\$166,000	\$20,000	\$186,000	836,000	\$72,500
Reed Park	40,000	\$1,700,000	\$148,000	\$20,000	\$168,000	514,000	\$106,500
Clover Park	400,000	\$5,300,000	\$462,000	\$25,000	\$487,000	5,143,000	\$30,900

1. The project cost includes construction, design, and construction management.

2. Does not include burdened salary for Watershed rogram Manager or administrative expenses.

3. For the purpose of conceptual level assessment, a 2-week cycle is assumed for filling and use of the harvested water during the wet season (October through March). No dry season flows are included.

4. Current retail cost of potable water is generally less than \$1,000 per acre-foot.



## **APPENDIX F: Review of Geotechnical Reports**

---



### Review of Geotechnical Reports

No.	Project Name	Project Location	Percolation Rate	# of Logs	Predominant Soil Type Near Surface
1	Big Blue Bus	1660 7th Street Santa Monica, CA	B-8: 0.4 to 4.0 (gal/ft <sup>2</sup> /day) = 0.032 to 0.27 (inch/hour) B-10: 0.004-0.04 (gal/ft <sup>2</sup> /day) = 0.00032 to 0.0027 (inch/hour)	N/A	N/A
2	Douglas DC-3 Monument Project	Southwest Corner of Airport Avenue & Donald Douglas Loop South Santa Monica, CA	N/A	2	Silty Sand
3	City of Santa Monica Parking Structure #4	2nd Street (Between Arizona Ave and Santa Monica Boulevard) Santa Monica, CA	N/A	2	B-1: Lean Clay B-2: Poorly Graded Sand
4	City of Santa Monica Parking Structure #5	1440 Fourth St Santa Monica, CA	N/A	2	Clayey Silt
5	Mountain View Mobile Home Park	1930 Stewart Street Santa Monica, CA	N/A	13	A-2: Clay A-3: Sandy Clay A-4: Sandy Clay/Clay A-5: Silty Sand A-6: Sandy Clay/Silty Sand A-7: Clay A-8: Silty Sand A-9: Silty Sand A-10 -- A-14: Clay
6	Santa Monica Recycling and Drop Off Facility Project	2411 Delaware Ave Santa Monica, CA	BH-1: 23.0 (minutes/inch) = 2.6 (inch/hour) BH-8: 299.7 (minutes/inch) = 0.2 (inch/hour)	9 (only two borings were used to determine percolation rate)	BH-1: Clayey Sand/Sand BH-8: Clayey Sand/Clay/Sand
7	City of Santa Monica Parking Structures #1 and #6	1234 4th Street and 1431 2nd Street Santa Monica, CA	N/A	8	B-1: Silt with Sand B-2: Silt with Sand B-3: Silt with Clay and Sand B-4: Silt and Sand B-5: Sandy Silt with Clay B-6: Sandy Silt B-7: Sandy Silt B-8: Sandy Silt
8	Proposed Police, Fire and Emergency Operations Center	Olympic Drive & Fourth Street Santa Monica, CA	N/A	8	B-1: Silt with Sand B-2: Silt with Sand B-3: Silt with Clay and Sand B-4: Silt and Sand B-5: Sandy Silt with Clay B-6: Sandy Silt B-7: Sandy Silt B-8: Sandy Silt
9	City of Santa Monica City Hall Seismic Retrofit	1685 Main Street Santa Monica, CA	N/A	5	B-1 -- B-5: Lean Clay
10	Prior Ground Motion Study for City of Santa Monica City Hall	1686 Main Street Santa Monica, CA	N/A	9	B-1: Sandy Silt B-2: Silty Sand B-3: Silty Clay B-4: Silty Clay B-5: Silty Clay/Silty Sand B-6: Silty Sand B-7: Silty Clay/Silty Sand B-8: Silty Clay/Silty Sand
11	Bicknell Avenue Street Greening	Bicknell Avenue b/w Main Street and Ocean Ave Santa Monica, CA	0.25 (inch/hour)	4	B-1 -- B-4: Sandy Clay/Clayey Sand
12	Pier Storm Drain Improvement	1550 Parking Lot Santa Monica, CA	N/A	7	B-1 -- B-7: Sand (loose to medium dense)
13	Beach Greening	2030 Barnard Way Santa Monica, CA	60 (inch/hour)	5	B-1 -- B-5: Silty Sand
14	Colorado Ocean Relief Sewer	Colorado Avenue & Ocean Ave, Santa Monica, CA	N/A	11	B-1 -- B-11: Unclassified mix of soils, including dense clayey sand, firm to still clay, and silt



# **APPENDIX G: Pico-Kenter Trash BMPs Conceptual Level Cost Opinions for Alternatives 2 and 3**

# Pico-Kenter Trash BMP - Alternative 2, End of Pipe No Phasing

## Conceptual Level Preliminary Construction Costs

<b>Design Items</b>	<b>Total Cost</b>
Earthwork & Dewatering	\$1,192,500
Hydrodynamic Separators (CDS® or equivalent), Diversion Structures and Piping	\$2,351,000
Sewer Diversion Capability at Pico-Kenter PS & Improvements to Dry Weather Diversion	\$120,800
Subtotal 1, Direct Construction Costs	<u>\$3,664,300</u>
Mobilization (5%)	\$183,215
Permits (5%)	\$183,215
Allowances (5%)	<u>\$183,215</u>
Subtotal 2	<u>\$4,213,945</u>
Estimating Contingency (25%)	<u>\$1,053,486</u>
Subtotal 3	<u>\$5,267,431</u>
Escalation (1 yr, 3%)	<u>\$158,023</u>
Subtotal 4	<u>\$5,425,454</u>
Construction Contingency (10%)	\$542,545
<b>Construction Cost Total</b>	<b><u>\$5,968,000</u></b>

## Conceptual Level Preliminary Total Project Costs

<b>Cost Items</b>	<b>Total Cost</b>
Construction Costs	\$5,968,000
Design (10% of Construction Costs)	\$597,000
Construction Management (10% of Construction Costs)	\$597,000
<b>Total Project Costs</b>	<b><u>\$7,162,000</u></b>

# Pico-Kenter Trash BMP - Alternative 3, End of Pipe Phasing

## Conceptual Level Preliminary Construction Costs

<b>Phased Construction Costs</b>	<b>Total Cost</b>
Phase 1, FY2010-11 (One unit installed at the northwest side of the P-K Outlet)	\$2,933,000
Phase 2, FY2012-13 (Another unit installed at the southeast side of the P-K Outlet)	\$1,806,000
Phase 3, FY2014-15 (Three additional units installed at the northwest side of the P-K Outlet)	\$2,742,000
<b>Construction Cost Total</b>	<b>\$7,481,000</b>

## Conceptual Level Preliminary Total Project Costs

<b>Cost Items</b>	<b>Total Cost</b>
Construction Costs (Total of All Phases)	\$7,481,000
Design (15% of Construction Costs - Total of All Phases)	\$1,123,000
Construction Management (15% of Construction Costs - Total of All Phases)	\$1,123,000
<b>Total Project Costs</b>	<b>\$9,727,000</b>

<b>Total Phase 1 Project Cost (with Design and Construction Management) =</b>	<b>\$3,813,000</b>
<b>Total Phase 2 Project Cost (with Design and Construction Management) =</b>	<b>\$2,348,000</b>
<b>Total Phase 3 Project Cost (with Design and Construction Management) =</b>	<b>\$3,566,000</b>



## Pico-Kenter Trash BMP - Alternative 3, Phase 1 (FY 2010-11)

### Conceptual Level Preliminary Construction Costs

<b>Design Items</b>	<b>Total Cost</b>
Earthwork & Dewatering	\$462,500
Hydrodynamic Separators (CDS® or equivalent), Diversion Structures and Piping	\$1,217,000
Sewer Diversion Capability at Pico-Kenter PS & Improvements to Dry Weather Diversion	\$120,800
Subtotal 1, Direct Construction Costs	<u>\$1,800,300</u>
Mobilization (5%)	\$90,015
Permits (5%)	\$90,015
Allowances (5%)	<u>\$90,015</u>
Subtotal 2	<u>\$2,070,345</u>
Estimating Contingency (25%)	<u>\$517,586</u>
Subtotal 3	<u>\$2,587,931</u>
Escalation (1 yr, 3%)	<u>\$77,638</u>
Subtotal 4	<u>\$2,665,569</u>
Construction Contingency (10%)	<u>\$266,557</u>
<b>Construction Cost Total</b>	<b><u>\$2,933,000</u></b>

### Conceptual Level Preliminary Total Project Costs

<b>Cost Items</b>	<b>Total Cost</b>
Construction Costs	\$2,933,000
Design (15% of Construction Costs)	\$440,000
Construction Management (15% of Construction Costs)	\$440,000
<b>Total Project Costs</b>	<b><u>\$3,813,000</u></b>

## Pico-Kenter Trash BMP - Alternative 3, Phase 2 (FY2012-13)

### Conceptual Level Preliminary Construction Costs

<b>Design Items</b>	<b>Total Cost</b>
Earthwork & Dewatering	\$438,000
Hydrodynamic Separators (CDS® or equivalent), Diversion Structures and Piping	\$606,900
Subtotal 1, Direct Construction Costs	<u>\$1,044,900</u>
Mobilization (5%)	\$52,245
Permits (5%)	\$52,245
Allowances (5%)	<u>\$52,245</u>
Subtotal 2	\$1,201,635
Estimating Contingency (25%)	<u>\$300,409</u>
Subtotal 3	\$1,502,044
Escalation (3 yr, 3%)	<u>\$139,280</u>
Subtotal 4	\$1,641,324
Construction Contingency (10%)	\$164,132
<b>Construction Cost Total</b>	<b><u>\$1,806,000</u></b>

### Conceptual Level Preliminary Total Project Costs

<b>Cost Items</b>	<b>Total Cost</b>
Construction Costs	\$1,806,000
Design (15% of Construction Costs)	\$271,000
Construction Management (15% of Construction Costs)	\$271,000
<b>Total Project Costs</b>	<b><u>\$2,348,000</u></b>

## Pico-Kenter Trash BMP - Alternative 3, Phase 3 (FY2014-15)

### Conceptual Level Preliminary Construction Costs

<b>Design Items</b>	<b>Total Cost</b>
Earthwork & Dewatering	\$952,500
Hydrodynamic Separators (CDS® or equivalent), Diversion Structures and Piping	\$543,000
Subtotal 1, Direct Construction Costs	<u>\$1,495,500</u>
Mobilization (5%)	\$74,775
Permits (5%)	\$74,775
Allowances (5%)	<u>\$74,775</u>
Subtotal 2	\$1,719,825
Estimating Contingency (25%)	<u>\$429,956</u>
Subtotal 3	\$2,149,781
Escalation (5 yr, 3%)	<u>\$342,404</u>
Subtotal 4	\$2,492,186
Construction Contingency (10%)	\$249,219
<b>Construction Cost Total</b>	<b><u>\$2,742,000</u></b>

### Conceptual Level Preliminary Total Project Costs

<b>Cost Items</b>	<b>Total Cost</b>
Construction Costs	\$2,742,000
Design (15% of Construction Costs)	\$412,000
Construction Management (15% of Construction Costs)	\$412,000
<b>Total Project Costs</b>	<b><u>\$3,566,000</u></b>



## **APPENDIX H: Approximate Treated Areas and Reduction of Urban Runoff & Estimated Costs per Drainage Area Treated**

**Approximate Treated Areas and Reduction of Urban Runoff  
Resulting from Measure V 5-Year Capital Improvement Plan**

Project ID No.	Project Type/Category	Estimated Drainage Area Treated (Acre)	Estimated Volume Reduction of Urban Runoff (MG/year)	Assumptions/Remarks
1	Permeable Surface Alleys	11	0.4	Approximately 1.1 acres of pervious concrete center swale will be installed in the 5-year period, as proposed in City's alley replacement program. Drainage area is based on 20-foot wide alley and 2-foot wide swale. Although potential infiltration will require further evaluation, 20% of a 3/4-inch storm over the drainage area is assumed to be the volume reduction. 10 rainfall events per year is assumed.
2	Permeable Surface Street Gutters/Intersections	22	0.9	Approximately 1.1 acres of pervious concrete center swale will be installed in the 5-year period, as proposed in City's street improvement program. Drainage area treated assumed to be approximately 20 times the area of installed pervious concrete street gutters/intersections. Although potential infiltration will require further evaluation, 20% of a 3/4-inch storm over the drainage area is assumed to be the volume reduction. 10 rainfall events per year is assumed.
3	Miniature Parkway/Sidewalk Biofilters	4.9	0.2	Approximately 4.9 acres of drainage area will be treated with parkway/sidewalk biofilters to be installed in the 5-year period. Although potential infiltration will require further evaluation, 20% of a 3/4-inch storm over the drainage area is assumed to be the volume reduction. 10 rainfall events per year is assumed.
4	Street Curb Extensions or Bulb-outs	1.7	0.8	Approximately 1.7 acres of drainage area will be treated with miniature parkway/sidewalk biofilters to be installed in the 5-year period. A total of 5 systems with a 15,000-gallon cistern per system is assumed. It is assumed that each cistern will be filled by the captured runoff 10 times per year.
5	Green Streets	3.5	0.1	Drainage area treated based on the approximate surface area of Ocean Park Blvd. between Neilson and Lincoln. Although potential infiltration will require further evaluation, 20% of a 3/4-inch storm over the drainage area is assumed to be the volume reduction. 10 rainfall events per year is assumed.
6	Permeable Surface Parking Lots	4.2	0.2	Approximately 4.2 acres of porous asphalt will be installed in the 5-year period, as proposed in City's facility program. Although potential infiltration will require further evaluation, 20% of a 3/4-inch storm over the drainage area is assumed to be the volume reduction. 10 rainfall events per year is assumed.
7	Park Retrofits			
	- Ozone Park	NA	0.2	Only a small portion of each storm event will be diverted for harvesting (i.e. not all of the flow from the upstream drainage area will be treated). The volume of harvested runoff is based on 2 weeks of storage between storm events during wet weather (October-March).
	- Marine Park	NA	1.2	
	- Memorial Park	NA	2.6	
8	Deep Infiltration In-Line Storm Drain Pilot Project	NA	NA	Pending results of pilot test.
9	Payment on J-2/J-3 Agreement with City of L.A.	57	Some reduction anticipated through proposed future water harvesting projects	Drainage area treated based on prorated share of \$1M (City of Santa Monica's share included as part of 5-Year CIP) for the total cost of \$86M to treat 4,920 acres as shown in Exhibit C of Draft MOA for J2/J3.
10	Trash BMPs	1,034	NA	Drainage area treated based on prorated share of 284 catch basin inserts/filters of a total of 1,164 catch basin inserts/filters within Kenter Canyon, Pico-Caltrans Basin, and Pico-4th Street Basins.
11	Downspout (DS) Redirect Program	NA	NA	Part of project category No. 12 or 13 below.
12	Rain Barrel Program	14	0.8	Drainage area treated based on 1,000 sf of roof area harvested by each rain barrel. The volume of harvested water based on a 125-gallon barrel filled 10 times per year. \$100 rebate per rain barrel assumed.
13	Cistern Program	46	5.0	Drainage area treated based on 2,000 sf of roof area harvested by each cistern. The volume of harvested water based on a 500-gallon cistern filled 10 times per year. \$250 rebate per cistern assumed.
	<b>Total</b>	<b>1,198</b>	<b>12.3</b>	Approximately 10.5 MG will be harvested and used for irrigation. Approximately 1.8 MG will be reduced by infiltration.

**Project Cost Per Drainage Area Treated  
Measure V 5-Year Capital Improvement Plan**

Project ID No.	Project Type/Category	Capital Cost (\$)	Drainage Area (Acre)	Capital Cost per Drainage Area (\$/Acre)	Remarks
1	Permeable Surface Alleys	\$367,907	11	\$34,600	Approximately 1.1 acres of pervious concrete center swale will be installed in the 5-year period, as proposed in City's alley replacement program. Drainage area is based on 20-foot wide alley and 2-foot wide swale.
2	Permeable Surface Street Gutters/Intersections	\$367,907	22	\$16,700	Approximately 1.1 acres of pervious concrete center swale will be installed in the 5-year period, as proposed in City's street improvement program. Drainage area treated assumed to be approximately 20 times the area of installed pervious concrete street gutters/intersections.
3	Miniature Parkway/Sidewalk Biofilters	\$423,615	4.9	\$86,500	Approximately 4.9 acres of drainage area will be treated with parkway/sidewalk biofilters to be installed in the 5-year period.
4	Street Curb Extensions	\$462,405	1.7	\$272,000	Approximately 1.7 acres of drainage area will be treated with miniature parkway/sidewalk biofilters to be installed in the 5-year period.
5	Green Streets	\$1,065,365	3.5	\$304,400	Drainage area treated based on the approximate surface area of Ocean Park Blvd. between Neilson and Lincoln.
6	Permeable Surface Parking Lots	\$216,439	4.2	\$51,400	Approximately 4.2 acres of porous asphalt will be installed in the 5-year period, as proposed in City's facility program.
7	Park Retrofits				
	- Ozone Park	NA	NA	NA	Only a small portion of each storm event will be diverted for harvesting (i.e. not all of the flow from the upstream drainage area will be treated). Cost per volume harvested was developed instead (see Appendix E).
	- Marine Park	NA	NA	NA	
	- Memorial Park	NA	NA	NA	
8	Deep Infiltration In-Line Storm Drain Pilot Project	NA	NA	NA	Pending results of pilot test.
9	Payment on J-2/J-3 Agreement with City of L.A.	\$1,100,122	57	\$19,200	Drainage area treated based on prorated share of \$1M (City of Santa Monica's share included as part of 5-Year CIP Plan) for the total cost of \$86M to treat 4,920 acres as shown in Exhibit C of Draft MOA for J2/J3.
10	Trash BMPs	\$4,045,925	1,034	\$3,900	Drainage area treated based on prorated share of 284 catch basin inserts/filters of a total of 1,164 catch basin inserts/filters within Kenter Canyon, Pico-Caltrans Basin, and Pico-4th Street Basins.
11	Downspout (DS) Redirect Program	NA	NA	NA	Part of project category No. 12 or 13 below.
12	Rain Barrel Program	\$76,507	14	\$5,600	Drainage area treated based on 1,000 sf of roof area harvested by each rain barrel. \$100 rebate per rain barrel assumed.
13	Cistern Program	\$318,778	46	\$6,900	Drainage area treated based on 2,000 sf of roof area harvested by each cistern. \$250 rebate per cistern assumed.



**DRAFT IMPLEMENTATION PLAN**

For compliance with the

**WET WEATHER  
SANTA MONICA BAY BEACHES BACTERIA  
TOTAL MAXIMUM DAILY LOAD (TMDL)**

March 15, 2005

Submitted to

**The Los Angeles Regional  
Water Quality Control Board**

## DRAFT IMPLEMENTATION PLAN

For compliance with the

WET WEATHER  
SANTA MONICA BAY BEACHES BACTERIA  
TOTAL MAXIMUM DAILY LOAD (TMDL)

March 15, 2005



## TABLE OF CONTENTS

	<u>Page</u>
<b>Executive Summary</b>	1
<b>1.0 Background</b>	2
Regulatory	
Historical Monitoring	
Physical Setting	
<b>2.0 Implementation Plan</b>	4
Continue to implement BMPs	
Review Sanitation District's Data	
Investigations	
<b>3.0 Conclusion</b>	5

## **1.0 EXECUTIVE SUMMARY**

On July 15, 2003, the Santa Monica Bay Beaches Bacterial Total Maximum Daily Load (TMDLs) for both wet and dry weather went into effect. As required by the TMDL for Wet-Weather, each Jurisdictional group must develop an implementation plan describing how compliance with the TMDL will be achieved. This draft "Implementation Plan" must be submitted to the Regional Board no later than March 15, 2005.

The beaches along the Palos Verdes Peninsula have historically had fewer exceedance days than the reference beach (Leo Carrillo) used by the TMDL to establish compliance. However, the anti-degradation provision of the TMDL does not allow more exceedances than established by historical precedent. Therefore, this implementation plan calls for the continued implementation of BMPs to maintain and improve existing water quality as required under the Municipal Stormwater Permit and its successors.

Should unanticipated exceedances occur, the Memorandum of Agreement (MOA) that the members of Jurisdictional Group 7 are a party to, contains provisions for investigation, correction and reporting of these exceedances.

## 1.0 Background

### 1.1 Regulatory

The Santa Monica Bay Beaches Bacteria TMDLs have been approved by the Los Angeles Regional Water Quality Control Board in two separate documents, a Wet Weather TMDL and a Dry Weather TMDL. The Dry Weather TMDL has been further divided into two segments; summer dry weather and winter dry weather. The net effect is three distinct compliance schedules:

Wet weather  
Summer dry weather (April 1 – October 31)  
Winter dry weather (November 1 – March 31)

These TMDLs establish a specific number of days for each of the above periods that a beach can have detected exceedances above the REC-1 (recreational use) bacteria levels established by the basin plan.

This Wet Weather TMDL allows a level of exceedances that takes the natural fluctuations of bacterial levels into account. The number of allowable exceedance days is based upon the reference beach (Leo Carrillo) or historical precedent whichever is less. The allowable number of exceedance days based upon the reference beach is 17.

As a requirement of the Wet Weather TMDL, an Implementation Plan must be prepared and submitted to the Regional Board by March 15, 2004. According to the TMDL:

*“Responsible jurisdictions and agencies shall provide a draft written report to the Regional Board outlining how each intends to cooperatively (through Jurisdictional Groups) achieve compliance with the TMDL. The report shall include implementation methods and implementation*

## 1.2 Historical Monitoring

The Los Angeles County Sanitation Districts has historically conducted monitoring at eight sampling locations along the Palos Verdes Peninsula beaches. Based on sampling by the Districts over a four-year period, 1997-2000, the TMDL has established that the beaches along the Palos Verdes Peninsula continually had fewer exceedances than the reference beach.

<b>Beach Monitoring Location</b>	<b>Exceedance Days<sup>1</sup></b>
Malaga Cove	14
Bluff cove	0
Long Point	5
Abalone cove	1
Portuguese Bend Cove	2
Royal Palms State Beach	6
White Beach (east)	17*
Wilder Annex	2
Cabrillo Beach (ocean side)	3

\*One additional monitoring location has been added as part of the development of the monitoring plan (separate document). There is no historical monitoring data for this location so the reference beach exceedance days are shown.

The anti-degradation provision of the TMDL does not allow a higher number of exceedance days, even if historical exceedances are less than the reference beach (17 days).

## 1.3 Physical Setting

Jurisdictional Group 7 is primarily comprised of portions of the cities of Los Angeles, Palos Verdes Estates, Rancho Palos Verdes, Rolling Hills and Rolling Hills Estates. It encompasses the ocean side of the Palos Verdes Peninsula and extends from the southern border of the City of Torrance to the breakwater of the outer Los Angeles Harbor.

The southern jurisdictional boundary of Santa Monica Bay (as established by the U.S. Coast Guard) extends to the outer Los Angeles Harbor breakwater. However, the prevailing “long shore” current which flows along the northern portions of Santa Monica Bay does not continue along the Palos Verdes Peninsula, making Jurisdictional Group 7 hydrologically distinct from the rest of the Santa Monica Bay beaches.

## **2.0 Implementation Plan**

The TMDL allows Jurisdictions to select one of two implementation strategies: integrated resource or non-integrated. As Jurisdictional Group 7 already meets the baseline goals and only needs to implement provisions to prevent “backsliding”; the non-integrated approach will be selected. No milestones are proposed, as existing conditions are the equivalent of compliance with the TMDL.

The implementation plan that the cities of Jurisdictional Group 7 will be employing consists of three primary actions:

### **2.1 Continue to implement BMPs**

Based upon the historical number of exceedance days being less than the reference beach, the Jurisdictional Group 7 cities will continue to implement BMPs with the goal of reducing the number of bacterial exceedance days.

These BMPs will include, but are not limited to: thorough inspections of sites listed as critical sources in the MS4 Permit, prompt response to spills and overflows, requirements that priority development projects treat stormwater runoff in accordance with SUSMP guidelines, regular public outreach, etc.

bacterial levels detected with follow-up sampling. The results of the Sanitation Districts sampling will be regularly reviewed. The Jurisdictional Group intends to explore the feasibility of posting the sampling results on a website accessible to the public.

### 2.3 Investigations

The Memorandum of Agreement developed by the Jurisdictional Group provides funding for investigations. The investigations will be initiated when deemed necessary by the Jurisdictional Group or as directed by the Regional Board.

Jurisdictional Group 7 intends to conduct these investigations in accordance with investigative protocols consistent with the other Santa Monica Bay Jurisdictional Groups (these protocols are yet to be developed). The protocol is assumed to include interviews, photographs, research, sample collection and analysis, etc.

## **3.0 Conclusion**

The Beaches of Jurisdictional Group 7 have historically had fewer bacterial exceedance days than the reference beach used by the Wet Weather TMDL. The natural characteristics of the Palos Verdes Peninsula coupled with BMPs that are already being implemented by the municipalities, appear to be an effective combination based on the relatively few historical number of exceedance days. The cities comprising Jurisdictional Group 7 have and will continue to implement BMPs that maintain or reduce the number of wet weather exceedance days. In the event that an excessive number of exceedances occur, the Jurisdictional Group has a mechanism in place to investigate and correct the cause(s).



## IMPLEMENTATION PLAN

For compliance with the

WET WEATHER  
SANTA MONICA BAY BEACHES BACTERIA  
TOTAL MAXIMUM DAILY LOAD (TMDL)

July 15, 2005

Submitted to

The Los Angeles Regional  
Water Quality Control Board

## IMPLEMENTATION PLAN

For compliance with the

WET WEATHER  
SANTA MONICA BAY BEACHES BACTERIA  
TOTAL MAXIMUM DAILY LOAD (TMDL)

July 15, 2005

Submitted on behalf of and  
as approved by Jurisdiction Group 7 by:

---

Dean E. Allison, P.E.  
Director of Public Works  
City of Rancho Palos Verdes



## TABLE OF CONTENTS

	<u>Page</u>
<b>Executive Summary</b>	1
<b>1.0 Background</b>	2
Regulatory	
Historical Monitoring	
Physical Setting	
<b>2.0 Implementation Plan</b>	4
Continue to implement BMPs	
Review Sanitation District's Data	
Investigations	
<b>3.0 Conclusion</b>	5

## **1.0 EXECUTIVE SUMMARY**

On July 15, 2003, the Santa Monica Bay Beaches Bacterial Total Maximum Daily Load (TMDLs) for both wet and dry weather went into effect. As required by the TMDL for Wet-Weather, each Jurisdictional group must develop an implementation plan describing how compliance with the TMDL will be achieved. This Implementation Plan must be submitted to the Regional Board no later than July 15, 2005.

The beaches along the Palos Verdes Peninsula have historically had fewer exceedance days than the reference beach (Leo Carrillo) used by the TMDL to establish compliance. However, the anti-degradation provision of the TMDL does not allow more exceedances than established by historical precedent. Therefore, this implementation plan calls for the continued implementation of BMPs to maintain and improve existing water quality as required under the Municipal Stormwater Permit and its successors.

Should unanticipated exceedances occur, the Memorandum of Agreement (MOA) that the members of Jurisdictional Group 7 will be a party to, contains provisions for investigation, correction and reporting of these exceedances.

## 1.0 Background

### 1.1 Regulatory

The Santa Monica Bay Beaches Bacteria TMDLs have been approved by the Los Angeles Regional Water Quality Control Board in two separate documents, a Wet Weather TMDL and a Dry Weather TMDL. The Dry Weather TMDL has been further divided into two segments; summer dry weather and winter dry weather. The net effect is three distinct compliance schedules:

- Wet weather
- Summer dry weather (April 1 – October 31)
- Winter dry weather (November 1 – March 31)

These TMDLs establish a specific number of days for each of the above periods that a beach can have detected exceedances above the REC-1 (recreational use) bacteria levels established by the basin plan.

This Wet Weather TMDL allows a level of exceedances that takes the natural fluctuations of bacterial levels into account. The number of allowable exceedance days is based upon the reference beach (Leo Carrillo) or historical precedent whichever is less. The allowable number of exceedance days based upon the reference beach is 17.

As a requirement of the Wet Weather TMDL, an Implementation Plan must be prepared and submitted to the Regional Board by July 15, 2005. According to the TMDL:

*“Responsible jurisdictions and agencies shall provide a written report to the Regional Board outlining how each intends to cooperatively (through Jurisdictional Groups) achieve compliance with the TMDL. The report shall include implementation methods, and implementation*

## 1.2 Historical Monitoring

The Los Angeles County Sanitation Districts has historically conducted monitoring at eight sampling locations along the Palos Verdes Peninsula beaches. Based on sampling by the Districts over a four-year period, 1997-2000, the TMDL has established that the beaches along the Palos Verdes Peninsula continually had fewer exceedances than the reference beach.

<b>Beach Monitoring Location</b>	<b>Exceedance Days<sup>1</sup></b>
Malaga Cove	14
Bluff cove	0
Long Point	5
Abalone cove	1
Portuguese Bend Cove	2
Royal Palms State Beach	6
White Beach (east)	17*
Wilder Annex	2
Cabrillo Beach (ocean side)	3

\*One additional monitoring location has been added as part of the development of the monitoring plan (separate document). There is no historical monitoring data for this location so the reference beach exceedance days are shown.

The anti-degradation provision of the TMDL does not allow a higher number of exceedance days, even if historical exceedances are less than the reference beach (17 days).

## 1.3 Physical Setting

Jurisdictional Group 7 is primarily comprised of portions of the cities of Los Angeles, Palos Verdes Estates, Rancho Palos Verdes, Rolling Hills and Rolling Hills Estates. It encompasses the ocean side of the Palos Verdes Peninsula and extends from the southern border of the City of Torrance to the breakwater of the outer Los Angeles Harbor.

The southern jurisdictional boundary of Santa Monica Bay (as established by the U.S. Coast Guard) extends to the outer Los Angeles Harbor breakwater. However, the prevailing “long shore” current which flows along the northern portions of Santa Monica Bay does not continue along the Palos Verdes Peninsula, making Jurisdictional Group 7 hydrologically distinct from the rest of the Santa Monica Bay beaches.

## **2.0 Implementation Plan**

The TMDL allows Jurisdictions to select one of two implementation strategies: integrated resource or non-integrated. As Jurisdictional Group 7 already meets the baseline goals and only needs to implement provisions to prevent “backsliding”; the non-integrated approach will be selected. No milestones are proposed, as existing conditions are the equivalent of compliance with the TMDL.

The implementation plan that the cities of Jurisdictional Group 7 will be employing consists of three primary actions:

### **2.1 Continue to implement BMPs**

Based upon the historical number of exceedance days being less than the reference beach, the Jurisdictional Group 7 cities will continue to implement BMPs with the goal of reducing the number of bacterial exceedance days.

These BMPs will include, but are not limited to: thorough inspections of sites listed as critical sources in the MS4 Permit, prompt response to spills and overflows, requirements that priority development projects treat stormwater runoff in accordance with SUSMP guidelines, regular public outreach, etc.

bacterial levels detected with follow-up sampling. The results of the Sanitation Districts sampling will be regularly reviewed. The Jurisdictional Group intends to explore the feasibility of posting the sampling results on a website accessible to the public.

### 2.3 Investigations

The Memorandum of Agreement developed by the Jurisdictional Group provides funding for investigations. The investigations will be initiated when deemed necessary by the Jurisdictional Group or as directed by the Regional Board.

Jurisdictional Group 7 intends to conduct these investigations in accordance with investigative protocols consistent with the other Santa Monica Bay Jurisdictional Groups (these protocols are yet to be developed). The protocol is assumed to include interviews, photographs, research, sample collection and analysis, etc.

## 3.0 **Conclusion**

The Beaches of Jurisdictional Group 7 have historically had fewer bacterial exceedance days than the reference beach used by the Wet Weather TMDL. The natural characteristics of the Palos Verdes Peninsula coupled with BMPs that are already being implemented by the municipalities, appear to be an effective combination based on the relatively few historical number of exceedance days. The cities comprising Jurisdictional Group 7 have and will continue to implement BMPs that maintain or reduce the number of wet weather exceedance days. In the event that an excessive number of exceedances occur, the Jurisdictional Group has a mechanism in place to investigate and correct the cause(s).

# APPENDIX G

## Surface Water Treatment Plant Improvements

### – Covina Irrigating Company



## WILLIAM B. TEMPLE WATER TREATMENT PLANT



Projects 1000 & 1001

# TREATMENT EVALUATION AND CONCEPTUAL COST ESTIMATE



San Gabriel Mountains (Photo by Gabi McLean © 2003)





# WILLIAM B. TEMPLE WATER TREATMENT PLANT

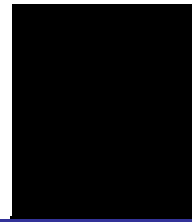

**MAY 2006**



# WILLIAM B. TEMPLE WATER TREATMENT PLANT TREATMENT EVALUATION AND CONCEPTUAL COST ESTIMATE

ES

## 1.0 EXECUTIVE SUMMARY

During times when water supplies from the State Water Project (SWP) exhibits either high natural organic matter (NOM) or high bromide concentrations or both, and at times when the CICo Temple Water Treatment Plant (WTP) must treat this water supply, high concentrations of disinfection byproducts (DBPs) may result. Due to the current configuration of the Temple WTP and the new Stage 2 DBP Rule (Stage 2), compliance is likely to be difficult under these circumstances.

A prior screening assessment of treatment technologies that would allow Stage 2 compliance resulted in the selection of either the MIEX treatment process for precursor removal or ultraviolet radiation (UV) and chloramines conversion for alternative disinfection as effective alternatives. However, due to uncertainty in the vendor supplied capital cost estimate provided by the MIEX supplier and preferred vendor, an additional treatment and cost estimate was performed. The new treatment and cost estimate was designed to provide both capital and operational and maintenance (O&M) cost estimates, and to include a third water supply option consisting of using local groundwater supplies with new well and conveyance facilities. Four new groundwater supply scenarios were developed by a team consisting of CICo, Malcolm Pirnie, and Stetson Engineering staff and evaluated.

Annual capital and O&M costs are given for the MIEX, UV, and lowest-cost groundwater supply options (Table ES-1). Also included in the table is net present value (NPV) total cost for a term of 20 years and a cost of money of 6%.

Key factors driving the costs of the three (3) treatment/supply options include:

- UV/Chloramines – cost of proprietary UV reactor and electrical costs,
- MIEX – cost of proprietary resin, new contactors and land, and brine disposal,



WILLIAM B. TEMPLE WATER TREATMENT PLANT  
TREATMENT EVALUATION AND CONCEPTUAL  
COST ESTIMATE

ES

- Groundwater – conveyance pipeline, pumping costs, and replenishment costs.

**Table ES-1 - Comparison of Capital, O&M, and NPV costs for Three Treatment Options for the Temple WTP.**

Treatment/Supply Alternative	Annual Costs (\$2006)		NPV (\$2006/AF)
	Capital	O&M	
UV/Chloramines	1,900,000	124,000	24
MIEX	12,200,000	462,000	138
Groundwater Delivery	7,200,000	3,200,000	135

In addition, an evaluation of the CICo distribution system was performed to evaluate the issues associated with converting the system to chloramines. It was determined that with the installation of a new valve, the system could be divided into two halves: 1) one half supplied by the Baldwin Park wellfield and using residual free chlorine disinfection, and 2) one half supplied by the Temple WTP using chloramines for residual disinfection. The volume of water expected to reach the terminal reservoirs and pump stations in the CICo system was not predicted to be significant.

This evaluation is intended to address DBP Rule compliance in the CICo water supply system. One important outstanding issue for treatment technology selection and capital improvements to the Temple WTP are the results from the required *Cryptosporidium Parvum* oocysts monitoring inherent in the Long Term 2 Enhanced Surface Water Treatment Rule (LT2), which became effective at the same time as the Stage 2 DBP Rule. Occurrence of *Cryptosporidium* in the CICo watershed may require increased filtration or disinfection capabilities at the Temple WTP. **Depending on**



WILLIAM B. TEMPLE WATER TREATMENT PLANT  
TREATMENT EVALUATION AND CONCEPTUAL  
COST ESTIMATE

ES

*Cryptosporidium* concentrations, the installation of UV disinfection may also address this risk, as UV is included in the “toolbox” of methods to address *Cryptosporidium* occurrence. However, a complete understanding of treatment upgrades to the Temple WTP or accurate sizing of a UV disinfection system will require some understanding of the *Cryptosporidium* occurrence risk.

Based on this DBP Rule compliance evaluation and lifecycle cost estimate of alternatives, we recommend UV disinfection and a chloramine conversion in the distribution system, subject to re-assessment pending *Cryptosporidium* occurrence data.



# WILLIAM B. TEMPLE WATER TREATMENT PLANT TREATMENT EVALUATION AND CONCEPTUAL COST ESTIMATE

1

## 1.0 INTRODUCTION

Covina Irrigating Company (CICO) operates the Temple Water Treatment Plant situated in Covina, CA, with a rated capacity of 12.5 million gallons per day (MGD). The Temple WTP is a conventional surface water treatment plant that can treat water from either a local water source (the headwaters of the San Gabriel River) or water supplies imported using the State Water Project (SWP). Due to the variable water quality of the SWP, which can have either elevated natural organic matter (NOM) concentrations or elevated bromide concentrations, or both, the Temple WTP may produce relatively high concentrations of disinfection byproducts (DBPs). If operated using this source for an extended period of time, CICO is at risk of violating the regulatory standards under the current Stage 2 Disinfection Byproduct Rule.

A technology screening assessment was previously conducted to determine the most appropriate technologies for DBP rule compliance at the Temple WTP given the current configuration of the plant and CICO's preference for continuing free chlorine residual disinfection. The technology screening assessment determined that either MIEX treatment (a precursor removal technology) or a switch to ultraviolet disinfection (UV) and residual disinfection using chloramines were viable alternatives. Given CICO's operational preference for free chlorine, a capital cost estimate for the MIEX process was solicited from the proprietary vendor of this process. This cost estimate contained some uncertainties and indicated that relatively high capital costs may be incurred, therefore an additional feasibility study was performed to determine lifecycle costs for the two recommended alternatives. In addition, a third option was studied that assessed the feasibility of developing groundwater resources in the area to either directly mitigate DBP formation at the Temple WTP or to replace the entire output of the Temple WTP. This report describes the results of this treatment and conceptual cost assessment, and



# WILLIAM B. TEMPLE WATER TREATMENT PLANT TREATMENT EVALUATION AND CONCEPTUAL COST ESTIMATE

1

presents the lifecycle costs in terms of annual capital and O&M costs as well as the net present value (NPV) of these costs over a typical operating and financing period.



## 2.0 MIEX

### FUNDAMENTALS OF MIEX®

The Magnetized Ion Exchange (MIEX®) resin and the MIEX® process were developed to remove natural organic matter (NOM) from water. MIEX® is a recognized alternative to enhanced coagulation, granular activated carbon (GAC) adsorption, and nanofiltration (NF). Removing natural organic matter from water prior to disinfection prevents the formation of disinfection byproducts (DBPs) in the treatment plant and later in the distribution system.

The MIEX® process removes dissolved organic carbon (DOC) in natural water through a continuous anion exchange. Some full-scale MIEX® applications demonstrate the resin's preference for low molecular weight NOM, while others demonstrate its affinity for high molecular weight NOM. Negatively-charged chloride ions (Cl<sup>-</sup>) are weakly bonded to fresh or regenerated resin; many DOC compounds present in natural waters have negatively-charged sites in their molecular structure. Upon exposure of the MIEX® resin to the dissolved organic matter, the negatively-charged chloride ions (Cl<sup>-</sup>) are released to the water, and the organic molecules attach to the resin at the available sites. In addition to organic matter, other anions in the water, such as sulfate (SO<sub>4</sub><sup>2-</sup>), are also exchanged for chloride.

MIEX® resin and the MIEX® process were developed by the Australian Water Quality Centre (AWQC) in collaboration with Orica Watercare, Inc. and the Commonwealth Scientific & Industrial Research Organisation (CSIRO). Both the MIEX® resin and process are patented internationally.

### Resin Properties



# WILLIAM B. TEMPLE WATER TREATMENT PLANT

## TREATMENT ASSESSMENT AND CONCEPTUAL COST ESTIMATE

2

MIEX® resin is composed of small, spherical, strong-base beads with a magnetized component within their structures that allows the beads to act as weak individual magnets. This magnetized resin was developed for the reversible removal of negatively-charged organic ions over a wide range of pH values. MIEX® resin beads are 150 - 180 µm in diameter, compared to a typical ion exchange resin with beads 300 - 1,200 µm in diameter. Contrary to the traditional fixed bed of larger size beads, the MIEX® resin is applied as a suspension.

Due to its large surface area and numerous active exchange sites on the resin surface, the MIEX® resin demonstrates higher rates of DOC removal. Under slight to moderate agitation, the resin beads remain well-separated, thus exposing their entire surface for reaction. Upon entry to a quiescent tank, however, the beads' magnetic properties cause them to attach to each other and settle quickly. The magnetic properties of the resin also help it to be separated from the water for later regeneration and reuse. The combination of small size and magnetic polarization yields a resin with unique properties that can remove low-molecular weight NOM more efficiently than other technologies.

### **Operation**

A typical plant utilizing MIEX® resin does not require pretreatment or additives such as oxidants, coagulants, and powered activated carbon. Additionally, DOC removal with MIEX® lowers the required coagulant dose downstream, effectively minimizing sludge production. Shown in Figure 2.1, the raw water and the MIEX® resin suspension meet at the stirred contact chamber, which is similar to a conventional flash mixer. The low level of agitation in this mixed chamber is adequate to keep the resin in suspension, exposing the resin surfaces for anionic exchange. Detention in the mixing tank enables high DOC uptake by the resin.





# WILLIAM B. TEMPLE WATER TREATMENT PLANT TREATMENT ASSESSMENT AND CONCEPTUAL COST ESTIMATE

2

Next, the contents of the mixing tank flow by gravity to a quiescent settling chamber where the resin (with adsorbed DOC) separates from the treated water and settles. The magnetic properties of the resin allow it to rapidly agglomerate into larger, more easily settled particles that can be removed from the bottom as a concentrated stream (20-30% v/v) for recycle or regeneration. A typical resin bead is recycled a number of times before it is regenerated. A small percentage of the resin in the recycle line is continuously directed to the regeneration tank and replaced with fresh, regenerated resin before entering the mixing tank. The treated water is discharged from the settler overflow.

**Figure 2.1 - A typical MIEX® Plant Flow Diagram (Orica Watercare, Inc., 2006).**

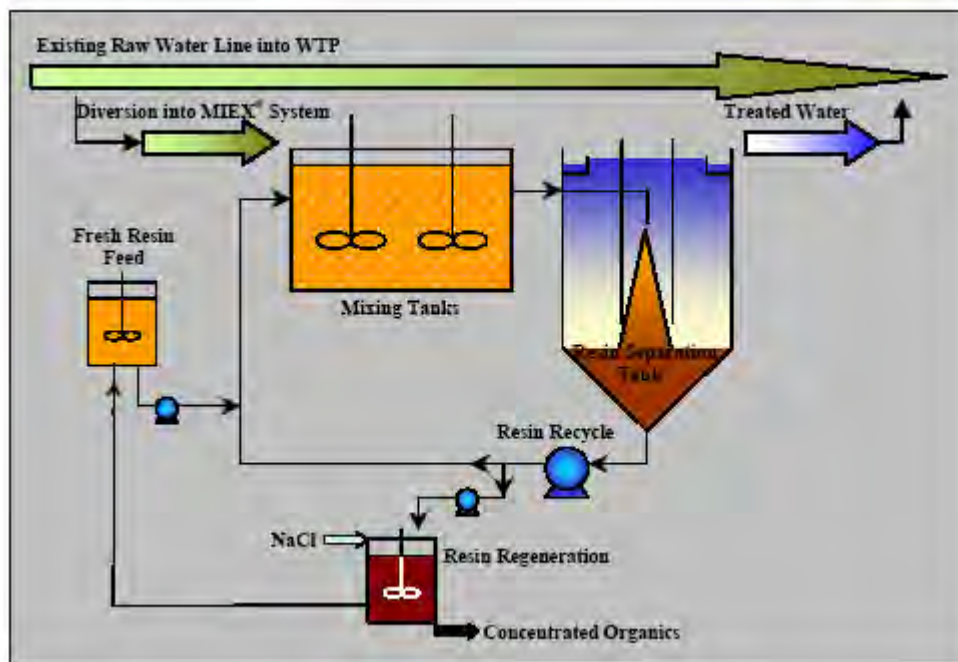

In regeneration, exposure to high concentrations of a brine solution enables the replacement of the adsorbed organics and other negatively-charged ions with chloride



# WILLIAM B. TEMPLE WATER TREATMENT PLANT TREATMENT ASSESSMENT AND CONCEPTUAL COST ESTIMATE

2

ions. The regenerated resin suspension is stored in a mixed feed tank. The waste stream, composed of concentrated organics and brine waste, is discharged for disposal or treatment.

## 2.1 KEY DESIGN PARAMETERS

The parameters important to the performance of the MIEX® process are listed in Table 2.1. These parameters can be optimized to accommodate water quality changes. For example, adjustments can be made to accommodate changes the nature of DOC in the water supply.

**Table 2.1 - MIEX® operational parameters.**

Parameters	Typical Range	Description
Regeneration Rate	5-10 percent of resin per cycle	Percent of resin directed to the regeneration tank.
Resin Concentration	10-30 mL resin per liter water	Resin loading in the mixing tank.
Residence Time	10-30 minutes	Contact time in the mixing contact chamber.

### REGENERATION RATE

A resin bead passes through the MIEX® process a number of times before regeneration. With each recycle, the resin's original capacity is reduced as DOC attaches to the



# WILLIAM B. TEMPLE WATER TREATMENT PLANT TREATMENT ASSESSMENT AND CONCEPTUAL COST ESTIMATE

2

available sites. Increasing the regeneration rate increases the resin sites available for DOC removal. This increase in performance is accomplished at the expense of additional regeneration process cycles and waste disposal.

## RESIN CONCENTRATION

An increase in the resin concentration translates to additional sites for anionic exchange in the stirred contact tank. Generally, as the resin concentration is increased, the degree of DOC removal increases. As the available resin sites increase, less contact time is required to achieve the desired DOC removal. Increasing the regeneration capacity can accommodate the higher resin concentration without the capital investment of purchasing new resin. The greater regeneration capacity will consequently increase the waste stream.

## RESIDENCE TIME

When the contact time is increased in the mixing tank, DOC removal increases. Although the MIEX® beads are smaller than typical resin exchange media, the efficiency of the MIEX® resin is influenced somewhat by diffusion of DOC through the bead/liquid interface and in the bead pores. Increasing the contact time increases the contact chamber volume requirements, reduces the water through-put rate, and reduces the resin concentration.

The operational parameters are also dependent on the concentration of negatively-charged ions in the water (such as sulfate) that compete with the DOC for the active MIEX® resin sites. The negative charge ions influence the overall efficiency of the MIEX® process and the regeneration efficiency.

## 2.2 ADDITIONAL OPERATIONAL BENEFITS



# WILLIAM B. TEMPLE WATER TREATMENT PLANT TREATMENT ASSESSMENT AND CONCEPTUAL COST ESTIMATE

2

Orica Watercare, Inc. reports the following operational benefits at full-scale MIEX® applications:

- Reduction in downstream coagulant dose;
- Reduction in sludge volumes;
- Reduction or elimination of pH-adjustment chemicals;
- Reduction in chlorine demand in disinfection;
- Improved filtration characteristics of treated water;
- Lowered settled water turbidity;
- Decreased filter backwash volumes.

## 2.3 WASTE STREAM

The liquid waste stream from the regeneration of the ion exchange media is discharged for disposal or treatment. The waste stream is composed of highly-concentrated sodium chloride that is used in resin regeneration, as well as the organic matter released during regeneration. As an anionic exchange resin, MIEX® also removes other negatively-charged ions from the water, such as sulfate.

Waste disposal is very site-specific, dependent on the wastewater treatment facility capacities, presence of anionic contaminants in the waste, and state and local regulations. Some full-scale MIEX® facilities have reported the disposal of waste brine as a key concern involving additional transportation or treatment costs, while other facilities continue to discharge to the sanitary sewer with no increase in cost.

## VOLUME

The chemical composition of the waste stream is influenced by the following:



# WILLIAM B. TEMPLE WATER TREATMENT PLANT TREATMENT ASSESSMENT AND CONCEPTUAL COST ESTIMATE

2

- Operating parameters of the MIEX® process described in Section 2.0;
- Organic matter concentration in the raw water;
- Negatively-charged ions that also adsorb to the MIEX® resin; and
- Concentration of the brine solution.

A 12.5 mgd treatment plant is expected to produce approximately 4,000-5,000 gallons of waste brine per day.

## DISPOSAL OPTIONS

Both off-site treatment and on-site treatment alternatives are available for the waste stream of regeneration. Some full-scale MIEX® facilities within close proximity to an ocean have found ocean disposal of the brine waste to be feasible. Other options include:

- Discharge to wastewater treatment facility via a direct sewer line is most likely the most economical disposal option. This option requires that the sewer line have sufficient capacity and dilution potential, and the wastewater treatment facility be adequately sized and able to accept the waste.
- If available to the facility, the MIEX® regeneration waste may be discharged to a sewer system devoted for industrial wastewater or brine wastes.
- On-site evaporative, solar drying is an option for facilities in dry climates. Evaporation of the MIEX® waste stream reduces the volume, leaving solid waste for disposal.
- Mechanical dewatering is another option for onsite waste volume reduction.
- The organics in the waste stream may be coagulated with the use of ferric salts, such that the remaining filtered liquid for recycling may be reused by



# WILLIAM B. TEMPLE WATER TREATMENT PLANT TREATMENT ASSESSMENT AND CONCEPTUAL COST ESTIMATE

2

the MIEX® process. The concentration of sulfate and other ions needs to be low for reuse to be feasible.

## 2.4 FACILITY LAYOUT

The installation of a MIEX® process requires additional tanks, as described in Section 1.3. The limited empty space at the William B. Temple Water Treatment Plant cannot accommodate these tanks, or the building that houses the regeneration process. The following options are available for the installation of the MIEX® facility:

- Locate the MIEX® equipment offsite (USG-3 turnout);
- Purchase land adjacent to the current location boundaries for MIEX® process equipment;

Land adjacent to the current site (if land is available for purchase) and construction of a new regeneration building will increase the capital cost of MIEX® installation. It is recommended that the existing travelling bridge filters be re-evaluated and/or replaced so the MIEX® equipment can fit within the current site boundaries and the existing building can be utilized for the regeneration process.

## 2.5 COST ESTIMATE

Table 2.2 lists the parameters for the installation of the 12.5 MGD MIEX® process at the William B. Temple Water Treatment Plant, as provided by Orica Watercare, Inc. (2006). The opinion of probable construction cost and opinion of probable operational cost are showing in Table 2.3 and Table 2.4. The Orica Watercare, Inc. (2006) quotation is available as an appendix to this report.



WILLIAM B. TEMPLE WATER TREATMENT PLANT  
TREATMENT ASSESSMENT AND CONCEPTUAL COST  
ESTIMATE

Table 2.2 - MIEX® operational parameters at the 12.5MGD William B. Temple WTP.

Parameter	Operation
Regeneration Rate	5%
Resin Concentration	30 mL resin per liter water
Residence Time	15 minutes
Settling tank Loading rate	6.0 gpm/sq ft.



**WILLIAM B. TEMPLE WATER TREATMENT PLANT  
TREATMENT ASSESSMENT AND CONCEPTUAL COST  
ESTIMATE**

**Table 2.3. Opinion of Probable MIEX® Construction Cost.**

Description	Unit Cost	Installation	Subtotal
<b>12.5 MGD MIEX® Plant Equipment Supply Package</b>	\$ 1,960,000	\$ 490,000	\$ 2,500,000
22'x22'x21'-6" Concrete Contactor Tanks (2)			
22'x22'x25'-3" Concrete Settling Tanks (4)			
38'x20'x12' Regeneration Skid (with regen. equip.)			
8'-6"(diam.) x 12'-6" Mixed Brine Tank			
6'-1"(diam.) x 9'-1" Mixed Brine Tank			
7'-8"(diam.) x 11'-3" Resin Transfer Tank			
5'-3"x5'-3"x5'-3" Steel Virgin Resin Tank			
12'(diam.) x 15' FRP Salt Saturator			
<b>Initial MIEX® Resin Inventory (11,000 gal)</b>	\$ 438,000	\$ 109,500	\$ 550,000
<b>Equipment Spares</b>	\$ 117,000	\$ 29,300	\$ 150,000
Contactor/Settler Equipment			
Regeneration Equipment			
		<b>Subtotal</b>	<b>\$ 3,200,000</b>
<b>Yard Piping (10%)</b>			\$ 320,000
<b>Site Work/Grading (10%)</b>			\$ 320,000
<b>Electrical/Instrumentation (20%)</b>			\$ 600,000
<b>Regeneration Building<sup>1</sup>, Other Structural (10%)</b>			\$ 320,000
<b>Mechanical (20%)</b>			\$ 600,000
<b>Mobilization, Insurance Administration (8%)</b>			\$ 300,000
		<b>Subtotal</b>	<b>\$ 5,660,000</b>
<b>Construction Overhead and Profit (25%)</b>			\$ 1,400,000
		<b>Subtotal</b>	<b>\$ 7,060,000</b>
<b>Contingency (20%)</b>			\$ 2,100,000
		<b>Subtotal</b>	<b>\$ 9,200,000</b>
<b>Engineering Fees (20%)</b>			\$ 1,800,000
<b>Legal and Administrative Fees (5%)</b>			\$ 460,000
<b>Land Acquisition<sup>1</sup></b>	\$ 750,000	\$ -	\$ 750,000
<b>Opinion of Probable Construction Cost (land acquisition and new regeneration building)</b>			<b>\$ 12,210,000</b>

**MALCOLM  
PIRNIE**

**DRAFT**





WILLIAM B. TEMPLE WATER TREATMENT PLANT  
TREATMENT ASSESSMENT AND CONCEPTUAL COST  
ESTIMATE

Table 2.4. MIEX® annual operational and maintenance cost.

Description	Unit Cost	Subtotal
<b>General Operating Costs (per 1,000 gallons water treated)</b>	\$0.100	\$ 460,000
Resin Replacement		
Salt Consumption (400lb/MG; \$50/ton salt)		
Electrical Power (0.07 \$/KW.hr)		
<b>Personnel (per hour)</b>	\$31.00	\$ 2,000
<b>Opinion of Probable O&amp;M Cost</b>		<b>\$ 462,000</b>
<b>Opinion of Probable O&amp;M Cost (per 1000 gallons water treated)</b>		<b>\$ 0.10</b>

It is assumed that the waste can continue to be discharged into the sanitary sewer. It is expected that the William B. Temple Water Treatment Plant will experience cost benefits associated with the MIEX® process, including reduced coagulant use, reduced sludge volume, and reduced backwash frequency.



WILLIAM B. TEMPLE WATER TREATMENT PLANT  
TREATMENT ASSESSMENT AND CONCEPTUAL COST  
ESTIMATE

3

### 3.0 UV

The combination of UV disinfection and chloramines provides a high level of microbial inactivation with minimal disinfection by product (DBP) formation. This section provides an overview of UV disinfection and chloramination.

#### OVERVIEW OF UV DISINFECTION

UV disinfection use has grown in North America because it is the most cost effective method of inactivating Cryptosporidium. In 2005, there were over 40 UV installations in North America that had a combined capacity that is greater than 1,000 mgd. This section summarizes the fundamentals of UV disinfection and key UV facility design parameters to be considered.

UV disinfection utilizes high intensity UV light to inactivate microorganisms by damaging the microorganism's deoxyribonucleic acid (DNA) and ribonucleic acid (RNA), which prevents the microorganism from replicating. Conversely, traditional chemical disinfectants, such as chlorine, disinfect by damaging cellular structures, inhibiting biosynthesis, and affecting a microorganism's metabolism.

Several UV lamp technologies are currently being used. The two most common types are medium pressure and low pressure high output lamps. Medium pressure lamps emit UV light over the full spectrum of wavelengths, while low pressure high output lamps emit UV light primarily at 254 nm. Medium pressure lamps use more energy but the required footprint is significantly decreased due to fewer lamps being required for a given dose. Low pressure lamps require a larger footprint but are more energy efficient.

UV disinfection has been listed as a best available technology (BAT) for meeting the Long Term 2 Enhanced Surface Water Treatment Rule. It is effective at inactivating



# WILLIAM B. TEMPLE WATER TREATMENT PLANT TREATMENT ASSESSMENT AND CONCEPTUAL COST ESTIMATE

3

bacteria, Giardia, and Cryptosporidium without creating any additional regulated disinfection by products (DBPs).

## OVERVIEW OF CHLORAMINATION

Chloramines are formed when chlorine and ammonia are combined in water. Chloramines have been used in the United States since the beginning of the 1900s for the treatment of drinking water. Currently, the primary application of chloramines by water utilities is to provide a disinfection residual in the distribution system. Chloramine disinfection will help reduce DBP formation by “quenching” the free chlorine residual. Chloramine residuals persist longer than chlorine residuals in the distribution system, which helps maintain microbiological water quality.

## 3.1 DESIGN ASSUMPTIONS

For the Temple Water Treatment Plant (WTP), several design assumptions were made to develop the cost estimates for the UV disinfection and ammonia feed facility.

### UV DESIGN ASSUMPTIONS

UV disinfection design is largely based around three operating parameters: log inactivation of the target microorganism, flowrate, and UV transmittance (UVT). These parameters are used by the UV manufacturers to determine what UV reactors are applicable for the Temple WTP and will affect the size and cost of the UV facility.

Microbial log inactivation credit for the target microorganism is granted based on the full-scale validation testing and is a function of flowrate, UVT, and lamp output. The design target log inactivation was 3-log Cryptosporidium inactivation.



# WILLIAM B. TEMPLE WATER TREATMENT PLANT TREATMENT ASSESSMENT AND CONCEPTUAL COST ESTIMATE

3

Flowrate affects the residence time within the reactor and the particle path and exposure time of the microorganism. The design flowrate is 12.5 mgd based on the design flowrate of the current facility.

UVT is a measurement of how much UV light is transmitted through the water and is related to the UV absorbance of water at 254 nm by equation shown below. The available water quality data showed that the reservoir had a UVT of 80.2% and the untreated State Water Project water had a UVT range of 82.2% to 85.9%. Filtered water UVT data were not available at the time of this analysis. It was assumed that the filtered water UVT will be higher than the raw water sources because coagulation/flocculation and filtration will remove some of the organics. A conservative estimate of 85% was assumed as the design UVT.

$$UVT = 10^{-UVA_{254}} \times 100$$

Where: UVT = UV Transmittance in percent

$UVA_{254}$  = UV absorbance per centimeter at 254 nm

## UV REACTOR INFORMATION

The UV facility was designed to be operated at 12.5 mgd with only one reactor train in operation. The second train will serve as a back-up or can be utilized when maintenance is required on the operational UV reactor. The Temple WTP has a relatively constrained site, and a two UV reactor configuration will result in the smallest footprint at the design flow.

For this conceptual design, UV manufacturers were given the number of reactors needed (two total), target log inactivation, design flow, and design UVT, and they provided the



**WILLIAM B. TEMPLE WATER TREATMENT PLANT  
TREATMENT ASSESSMENT AND CONCEPTUAL COST  
ESTIMATE**

following information on candidate UV reactors (Table 3.1).

**Table 3.1 - UV Manufacturer Information.**

Design Parameter	Manufacturer			
	Aquionics	Calgon Carbon	Trojan	WEDECO
Total Number of Reactors (duty + standby)	2	2	2	2
Lamp Type	Medium Pressure	Medium Pressure	Medium Pressure	Low Pressure High Output
Influent Pipe Diameter (in)	20	36	24	48
Upstream Straight Pipe Length (ft)	8.33	15	10	20
Downstream Straight Pipe Length (ft)	3.33	6	4	8
Center point Distance Between Reactors (ft)	3	5.6	4.83	12
Maximum Distance Between Reactors and Control Panel (ft)	300	500	32(std) or 64	70
Total Power per Reactor at Design UVT (kW)	90	90	80	30.3
Headloss (in)	14	10.8	<10	5.5

**POWER AND ELECTRICAL CONSIDERATIONS**

The total installed electrical load depends on the UV reactor selected and the design UVT. If the operating UVT is found to be higher than the design UVT of 85%, the electrical costs could be lower if power modulation is provided with the UV equipment.



# WILLIAM B. TEMPLE WATER TREATMENT PLANT TREATMENT ASSESSMENT AND CONCEPTUAL COST ESTIMATE

3

The WEDECO reactor which uses low pressure high output lamps has the lowest connected load at 30.0 kW, but this reactor will require the greatest footprint. The reactors that use medium pressure lamps require a connected load of 80 or 90 kW.

Any interruption in the power supply will cause the reactors to shut down and several minutes will be required for the reactors to come back on to full power. A back-up generator was included in the conceptual design to reduce any down-time due to power outages.

## AMMONIA SYSTEM ASSUMPTIONS

The ammonia system is designed to convert the chlorine residual in the filtered water to a chloramine residual. The following assumptions were used to develop the conceptual ammonia system design.

- The target chloramine dose is to be 2.5 mg/L as  $\text{NH}_2\text{Cl}$ .
- An ammonia to chlorine ratio of 5:1  $\text{Cl}_2:\text{NH}_3\text{-N}$  by weight is used to promote monochloramine formation.
- The ammonia to be added as 19% aqua ammonia.
- A bulk tank is included, and the chemical feed pumps will draw directly from the bulk tank. A 6,000 gallon bulk tank is assumed because that volume provides the most cost-effective method of aqua ammonia delivery (i.e., smaller quantities cost more).
- A neutralization tank is included to provide backpressure on the bulk tank, which prevents the aqua ammonia from volatilizing.

Instead of bulk tanks, an ammonia tote system could be used, which would have a



# WILLIAM B. TEMPLE WATER TREATMENT PLANT TREATMENT ASSESSMENT AND CONCEPTUAL COST ESTIMATE

3

smaller footprint. If totes were utilized, approximately eight 350-gallon totes would be needed each month

## OTHER DESIGN ASSUMPTIONS

Several other assumptions were made in this conceptual design in order to develop the conceptual cost estimates.

- The flow in the filter effluent channels will be reversed, and a new header will collect the filtered water from each channel and route it to the northwest corner of the filter building. Therefore, it is assumed that flow in the filter effluent channels can be reversed without incurring a significant cost.
- Preliminary hydraulic calculations indicate that the current hydraulic profile will be able to accommodate a new UV facility without additional pumping. A more detailed hydraulic profile assessment is necessary to confirm that interstage pumping is not needed.
- The UV and Ammonia building is a pre-engineered building with no heating, ventilation, and air conditioning (HVAC) system.
- If the UV facility effluent pipe cannot be located sufficiently upstream from the metering vault, the accuracy of the meter may be affected.
- The footing of the existing filter building is assumed to not impact the UV facility piping layout.
- Fouling was assumed to be minimal, and the UV reactor will have automatic wipers to remove any fouling that occurs.
- The downstream butterfly valve will not be used for flow control because



WILLIAM B. TEMPLE WATER TREATMENT PLANT  
TREATMENT ASSESSMENT AND CONCEPTUAL COST  
ESTIMATE

3

additional headloss will be created and possibly result in the need for additional pumping.

### 3.2 UV DISINFECTION AND AMMONIA FACILITY LAYOUT

The UV and Ammonia facility will be built on the southwest corner of the filter effluent building. This allows for the building to fit adjacent to the filter building and maximizes the space available for parking. To utilize this location, the filter effluent flow will be reversed to flow west and will be collected in a new 24-inch header located in the current overflow collection vault. The filtered water header will be routed south to the new UV and ammonia facility.

For the facility layout, one UV manufacturer was chosen but this does not represent a preference for the chosen manufacturer. A 20 ft by 40 ft building will be necessary to house both the UV equipment and ammonia feed system. The ammonia feed system consists of a 6,000 gallon storage tank, a 200 gallon neutralization tank, and the associated pumping and piping requirements. The UV and Ammonia Facility configuration is shown in Figure 3.2.





WILLIAM B. TEMPLE WATER TREATMENT PLANT  
 TREATMENT ASSESSMENT AND CONCEPTUAL COST  
 ESTIMATE

Figure 3.2 – Conceptual UV Facility Layout

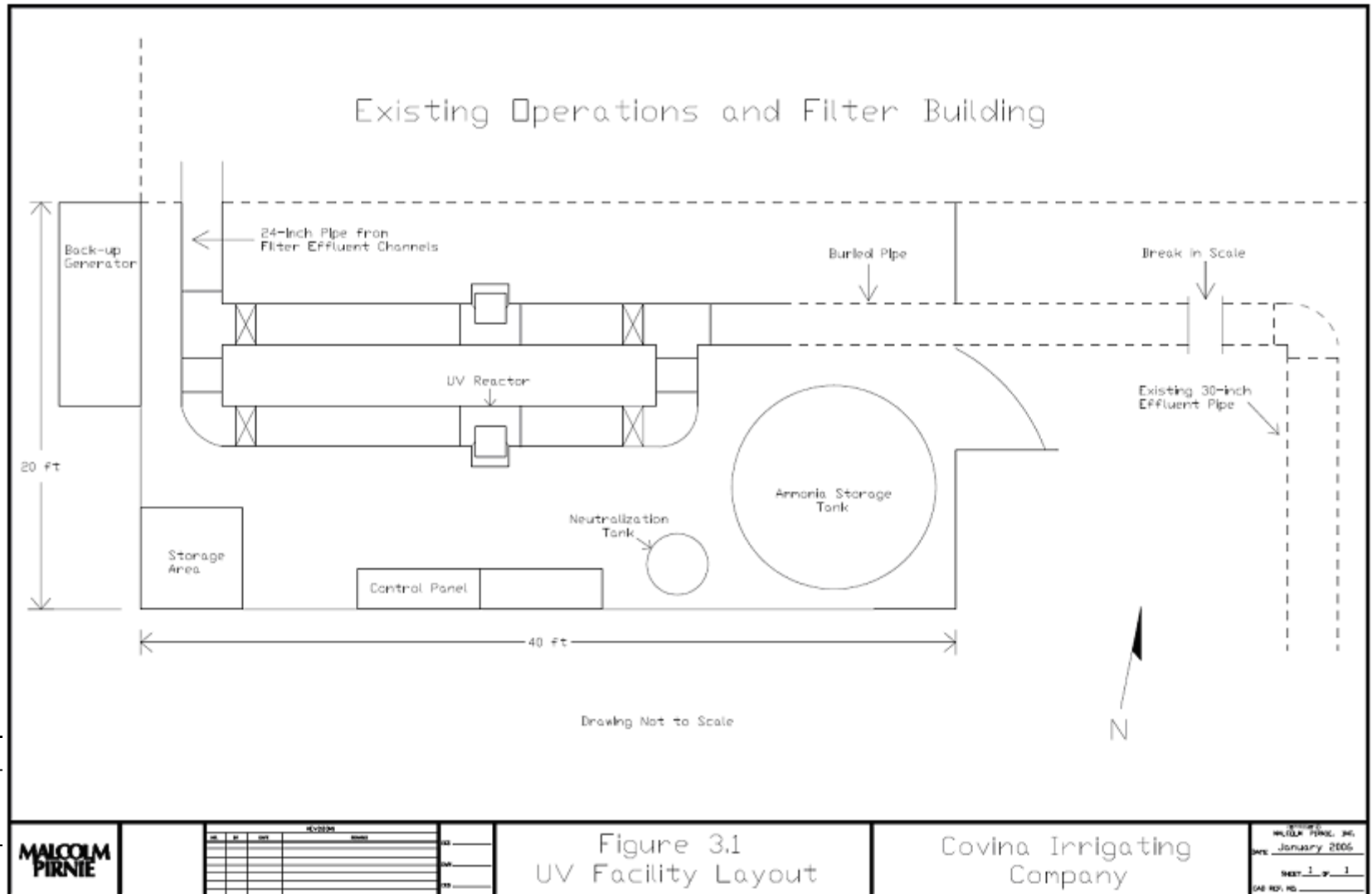

REVISION			
NO.	DATE	DESCRIPTION	BY

Figure 3.1  
 UV Facility Layout

Covina Irrigating  
 Company

DATE: January 2006  
 SHEET: 1 of 1  
 JOB NO.: 06



WILLIAM B. TEMPLE WATER TREATMENT PLANT  
TREATMENT ASSESSMENT AND CONCEPTUAL COST  
ESTIMATE

### 3.3 COSTS

The conceptual opinion of probable costs for construction and annual operations and maintenance costs are summarized in this section. The cost opinion was developed using vendor quotations and previous project cost data. All costs presented in this report are for January 2006 (20 Cities Average Engineering News Record Construction Cost Index = 7660).

The level of accuracy for the costs presented corresponds to the Association for the Advancement of Cost Engineering (AACE) level 2 cost estimate. Level 2 cost opinions have an accuracy range of -30 percent to +50 percent and are appropriate for conceptual design reports.

#### CAPITAL COSTS

The capital cost for this facility was estimated to be \$1.87 million (Table 3.2) based on the assumptions described in Section 3.0.

**Table 3.2 - Capital Cost Estimate for UV and Chloramination Facility**

Description	Unit Cost	Installation	Subtotal
<b>12.5 MGD UV Equipment</b>			
2 UV Reactors and Control Panels	\$ 418,000	\$ 83,600	\$ 502,000
<b>Piping and Valves</b>	\$ 102,000		\$ 102,000
<b>Back-up Generator</b>	\$ 35,000	\$ 10,000	\$ 45,000
<b>Chemical Feed Equipment</b>	\$ 44,000		\$ 44,000
<b>UV and Ammonia Building<sup>1</sup></b>	\$ 89,000		\$ 89,000



**WILLIAM B. TEMPLE WATER TREATMENT PLANT  
TREATMENT ASSESSMENT AND CONCEPTUAL COST  
ESTIMATE**

<b>Subtotal</b>		<b>\$ 782,000</b>
<b>Electrical/Instrumentation (20%)</b>		\$ 156,000
<b>Subtotal</b>		<b>\$ 938,000</b>
<b>Contingencies (30%)</b>		\$ 282,000
<b>Subtotal</b>		<b>\$ 1,220,000</b>
<b>Construction Overhead and Profit (25%)</b>		\$ 305,000
<b>Mobilization, Insurance Administration (8%)</b>		\$ 98,000
<b>Engineering (20%)</b>		\$ 244,000
<b>Opinion of Probable Construction Cost</b>		<b>\$ 1,867,000</b>

1. The UV and Ammonia Building Cost includes the necessary site work/grading.

As described previously, the cost calculations assumed that additional pumping will not be required. The addition of a pump could incur an additional \$60,000 in capital costs for the purchase and installation of a high flow low head pump. The pump costs are based on a information from a representative of Sulzer Pumps Inc.

**ANNUAL OPERATIONS AND MAINTENANCE**

The annual O&M costs are estimated to be approximately \$124,000 per year, including power costs, UV replacement parts, chemical costs, and estimated maintenance for the ammonia feed system. It was also assumed that a half-time operator will be required to operate the facility. A half time operator will be able to perform all of the required maintenance, reporting, and operation needs of the facility.



WILLIAM B. TEMPLE WATER TREATMENT PLANT  
TREATMENT ASSESSMENT AND CONCEPTUAL COST  
ESTIMATE

Note that the annual operating costs for UV disinfection do not include the potential patent fee of \$0.015 per 1000 gallons treated (\$188 per day at 12.5 mgd). The patent fee will be less if the facility is operating at a flow lower than the design flow of 12.5 mgd. The UV disinfection patent is currently under litigation, and it is unknown whether this cost will ultimately be incurred.

**Table 3.3 Annual Operation and Maintenance Costs**

Description	Unit Cost	Subtotal
<b>General Operating Costs (per 1,000 gallons water treated)</b>	\$ 0.020	\$ 92,000
UV Replacement Parts	\$ 14,000	
Aqua Ammonia Consumption (11.7 lb/MG; \$0.33/lb of Ammonia)	\$ 18,000	
Ammonia Feed System Maintenance	\$ 5,000	
Electrical Power (0.07 \$/KW-hr)	\$ 55,000	
<b>Personnel (per hour)<sup>1</sup></b>	\$ 31.00	\$ 32,000
<b>Opinion of Probably O&amp;M Costs</b>		<b>\$ 124,000</b>
<b>O&amp;M Cost per 1000 gal. treated</b>		\$ 0.03

<sup>1</sup> It was assumed that a half-time operator will be necessary to operate and maintain the UV and ammonia Facility

3.4 CHLORAMINES CONVERSION IN THE CICO  
DISTRIBUTION SYSTEM



# WILLIAM B. TEMPLE WATER TREATMENT PLANT TREATMENT ASSESSMENT AND CONCEPTUAL COST ESTIMATE

3

The CICO retail distribution system is relatively small, and supplies treated water from two sources, the Temple WTP and the Baldwin Park wellfield. Both sources are currently using free chlorine for residual disinfection. There are a number of other facilities in the system, including two (2) reservoirs: the City of Covina reservoir at Cypress Avenue, and the Surburban #110 reservoir. In addition, the Surburban Water Systems (SWS) Plants #119 and #168 are connections that lead to retail water systems and reservoirs. Two other notable facilities in the system are the City of Covina Forestdale Pump Plant (near San Bernardino Road and Grand Avenue) and a pressure reducing valve (PRV) that does not allow water in the southern portion of the system to move north of Cypress Avenue.

The primary goals of a chloramines conversion is to:

- Minimize chloraminated water age (reducing residual decay), and
- Prevent mixing of a chlorinated and chloraminated supplies in a reservoir (thus preventing unusual  $\text{Cl}_2:\text{NH}_3$  ratios and breakpoint chlorination).

In general, the Baldwin Park wellfield supplies water to the western portion of the distribution system, while the Temple WTP supplies both northern and eastern portion of the system. Based on system demands and the configuration described above, the only opportunity for these two water types to mix is in the southern reach of the distribution system south of San Bernardino Road on the way to the SWS #168 Plant. We have determined that the installation of a new butterfly valve in the 30" RCP main just past the Forestdale Plant will allow the bifurcation of the distribution system into two parts while allowing each water supply to maximize supply volumes. The Baldwin Park wellfield will continue to supply the western portion of the system up to and including the Forestdale Plant, thus consuming most the supply from the wellfield. The Temple WTP



WILLIAM B. TEMPLE WATER TREATMENT PLANT  
TREATMENT ASSESSMENT AND CONCEPTUAL COST  
ESTIMATE

will supply the northern and southern portions of the system to the east of the Forestdale Plant, including the SWS Plants. Demand should be such that the volume of water and water age arriving at the terminal pump stations and reservoirs is minimized.

## 4.0 GROUNDWATER SUPPLY OPTIONS

CICo has the right to develop additional groundwater supplies from one or more of three well sites:

- The “Contract” well,
- The “Valencia” well, and
- The aforementioned Baldwin Park wellfield.

Supplies developed at the Valencia and Contract well sites have existing connections and distribution facilities. Supplies developed at the Baldwin Park wellsite would need a conveyance pipeline constructed from the site to the Contract well site to allow blending prior to treatment at the Temple WTP.

Groundwater supplies may be used in two ways to address DBP formation at the Temple WTP. One, sufficient supplies may be developed and supplied indirectly to the Temple WTP to dilute SWP supplies to a level where DBP formation using free chlorine is manageable. We have estimated this would require approximately 10 MGD of capacity resulting in a blended TOC concentration of less than 1 mg/L (groundwater is assumed to have a negligible DBP formation potential). Two, sufficient supplies can be developed in



WILLIAM B. TEMPLE WATER TREATMENT PLANT  
TREATMENT ASSESSMENT AND CONCEPTUAL COST  
ESTIMATE

6

any combination of sites to produce 12.5 MGD of supplies and thus allow the temporary shutdown of the Temple WTP.

A working group of CICO, Malcolm Pirnie, and Stetson Engineering staff was convened to determine the supply alternatives available for the groundwater sources listed above. Four (4) scenarios were developed and considered for further pumping and water quality analysis. These four scenarios were:

Option 1: Use Contract and Valencia wells or develop new capacity at these sites and bring water into the Temple plant using existing pipelines.

Option 2: Develop 12.5 MGD at Baldwin Park Reservoir. Reactive booster station and move water back into 12" line and move PRV.

Option 3: Develop 6-7 MGD at Baldwin Park and build pipeline up to Contract well site.

Option 4: Talk to Suburban and bring water over to Contract well site.

The Contract and Valencia well sites contain nitrate that limits the volume of water that may be used from these sites. The Baldwin Park well site does not currently contain any regulated contaminants that would limit production; however, the site is near a known contaminant plume and pumping may cause contaminant migration to the well site. Development of groundwater supplies from these three sites would also require that Covina pay a replenishment fee. In addition, pumping into the distribution system from these sites required a significant amount pumping pressure, which also increases cost. A water quality and cost evaluation for these four scenarios was provided by Stetson Engineering and is contained in Appendix B.



WILLIAM B. TEMPLE WATER TREATMENT PLANT  
TREATMENT ASSESSMENT AND CONCEPTUAL COST  
ESTIMATE

All four (4) groundwater supply options are limited in the volume of water they can deliver. Option 1 is limited by nitrate concentrations and well capacity to 2500 gpm. Options 2 and 3 are limited by the ultimate production capacity of the wellfield, which is an additional 4,300 gpm. Option 4 was not viable due to supply constraints from the Suburban VCWD facility. Therefore, none of the groundwater supply options will allow the operation of the Temple WTP at full capacity or fully replace the Temple WTP production.

## 5.0 NET PRESENT VALUE COST ESTIMATION

A net present value cost estimate was generated for each supply scenario and treatment option. The use of this method of cost estimation has two advantages:

1. it allows easy comparison to the current cost of alternatives supplies to gauge relative cost, and
2. it allows a comparison using one value which reflects a combined cost consisting of up-front capital costs, financing (interest) costs, and O&M costs in the future discounted to the present.

Using this information in conjunction with a net present value model yields the following costs for the viable scenarios (Table 5.1):

**Table 5.1 – NPV Costs for the Three Alternatives.**

Cost of Money	6%
---------------	----





WILLIAM B. TEMPLE WATER TREATMENT PLANT  
TREATMENT ASSESSMENT AND CONCEPTUAL COST  
ESTIMATE

Inflation	3%
Plant Life	20 years
Groundwater Option 1	\$135/AF
Groundwater Option 2	\$251/AF
Groundwater Option 3	\$247/AF
UV/Chloramines	\$24/AF
MIEX	\$138/AF

## 6.0 SUMMARY

Two treatment options, MIEX and UV/Chloramines, can ensure the full use of the Temple WTP regardless of source of supply. The UV/Chloramines option represents a change in residual disinfection practices for the system, but an evaluation of the CICO distribution system suggests this is an acceptable practice. Based on the total cost and net present value of these two options, UV/Chloramines is the preferred option.

Due to the need for new well, wellhead, and possibly conveyance facilities, in addition to pumping and replenishment costs, the groundwater supply options are not cost-competitive options. In addition, it is unlikely that sufficient groundwater resources are available to meet water quality objectives at the Temple WTP or serve as a replacement supply for the full volume capacity of the plant. Groundwater remains a viable source for limited uses and future water supplies.



WILLIAM B. TEMPLE WATER TREATMENT PLANT  
TREATMENT ASSESSMENT AND CONCEPTUAL COST  
ESTIMATE

---

6

This evaluation is intended to address DBP Rule compliance in the CICO water supply system. One important outstanding issue for treatment technology selection and capital improvements to the Temple WTP are the results from the required *Cryptosporidium Parvum* oocysts monitoring inherent in the Long Term 2 Enhanced Surface Water Treatment Rule (LT2), which became effective at the same time as the Stage 2 DBP Rule. Occurrence of *Cryptosporidium* in the CICO watershed may require increased filtration or disinfection capabilities at the Temple WTP. **Depending on *Cryptosporidium* concentrations, the installation of UV disinfection may also address this risk, as UV is included in the “toolbox” of methods to address *Cryptosporidium* occurrence.** However, a complete understanding of treatment upgrades to the Temple WTP or accurate sizing of a UV disinfection system will require some understanding of the *Cryptosporidium* occurrence risk.

Based on this DBP Rule compliance evaluation and lifecycle cost estimate of alternatives, we recommend UV disinfection and a chloramine conversion in the distribution system, subject to re-assessment pending *Cryptosporidium* occurrence data.



WILLIAM B. TEMPLE WATER TREATMENT PLANT  
TREATMENT ASSESSMENT AND CONCEPTUAL COST  
ESTIMATE

---

6

APPENDIX A – GROUNDWATER SUPPLY OPTIONS  
ANALYSIS BY STETSON ENGINEERING

**Fallbrook Public Utility District**

990 East Mission Road • Fallbrook, CA 92028

---

# **UV Reactor Validation and Performance Verification Approach**

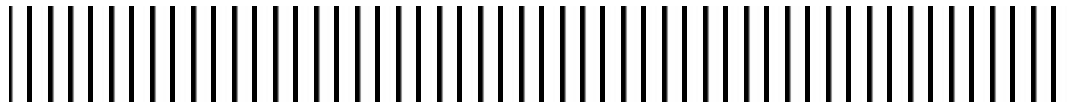

Report Prepared By:

**Malcolm Pirnie, Inc.**

1 S. Church Ave  
Suite 1120  
Tucson, AZ 85701  
(520) 629-8892

3861003

**MALCOLM  
PIRNIÉ**

---

## Contents

---

<b>1. Project Overview</b>	<b>1-1</b>
1.1. UV Facility Design Criteria .....	1-1
1.1.1. Target Pathogen Inactivation .....	1-1
1.1.2. Determination of Flows.....	1-1
1.1.3. UVT Data.....	1-3
1.1.4. Flow and UVT Design Points .....	1-4
1.2. Purpose of Memorandum .....	1-5
<b>2. Validation Fundamentals</b>	<b>2-1</b>
2.1. Biosimetry Overview .....	2-1
2.2. Limitations of Biosimetry.....	2-3
<b>3. UVDGM Validation Protocol Summary</b>	<b>3-1</b>
3.1. USEPA Method to Addressing Biosimetry Limitations .....	3-1
3.1.1. Example Validated Dose Calculation .....	3-2
3.2. UVDGM Method for Addressing Hydraulic Differences.....	3-3
<b>4. California UV Disinfection Technology Experience</b>	<b>4-1</b>
<b>5. FPU D Validation and Performance Demonstration Approach</b>	<b>5-1</b>
5.1. Approach for UV Facility Design and Validation.....	5-1
5.2. Logistical Issues for On-site Validation at RMR.....	5-2
5.3. Performance Demonstration .....	5-2
<b>6. Summary and Conclusions</b>	<b>6-1</b>
<b>7. References</b>	<b>7-1</b>

---

## List of Tables

---

Table 1-1. Flow Rate Summary (Design Points in Shaded Cells).....	1-3
Table 2-1. Calculated RED Based on Ideal Dose Distribution and UV Dose-Response Curves	2-4
Table 2-2. Calculated RED Based on Non-ideal Dose Distribution and UV Dose-Response Curves .....	2-6
Table 3-1. UV Dose Requirements (USEPA 2006).....	3-1
Table 4-1. UV Installations in California .....	4-1

## List of Figures

---

Figure 1-1: UV Transmittance Data for the RMR and the Skinner Filtration Plant.....	1-4
Figure 1-2: UV Transmittance Cumulative Frequency Diagram .....	1-5
Figure 2-1: Overview of USEPA Recommended Validation Protocol (USEPA, 2006) .....	2-2
Figure 2-2: UV Dose-Response Curves for Male-Specific-2 Bacteriophage and <i>Cryptosporidium</i> .....	2-4
Figure 2-3: Ideal UV Reactor Dose Distribution .....	2-5
Figure 2-4: Theoretical UV Dose Distribution .....	2-6

# 1. Project Overview

---

The Fallbrook Public Utilities District (FPUD) currently operates Red Mountain Reservoir (RMR), a 440 million gallon uncovered reservoir, that stores treated water purchased from the San Diego County Water Authority (SDCWA). To comply with the Long Term 2 Enhanced Surface Water Treatment Rule (LT2ESWTR), FPUD must either cover the reservoir or provide additional treatment on the discharge from the reservoir to provide 4-log virus, 3-log *Giardia*, and 2-log *Cryptosporidium* removal/inactivation. FPUD is currently designing a facility to meet the LT2ESWTR with a multi-barrier disinfection approach incorporating UV disinfection for *Giardia* and *Cryptosporidium* inactivation and free chlorine for virus inactivation.

## 1.1. UV Facility Design Criteria

The FPUD UV facility is being designed around three main criteria (i.e., pathogen inactivation, flow rate, and UV transmittance (UVT)). To limit the creation of off-specification water, conservative design values are being selected for all three design parameters.

### 1.1.1. Target Pathogen Inactivation

The UV reactors are being designed to achieve 3-log inactivation of *Cryptosporidium* and *Giardia* even though the LT2ESWTR only requires 2-log *Cryptosporidium* inactivation. *Cryptosporidium* is more resistant to UV disinfection than *Giardia* and has a slightly higher required dose for a given log inactivation (e.g., 12 mJ/cm<sup>2</sup> compared to 11 mJ/cm<sup>2</sup> for 3-log inactivation). Therefore, selecting the dose for 3-log *Cryptosporidium* provides additional flexibility to meet future water treatment goals at minimal additional costs.

### 1.1.2. Determination of Flows

The RMR provides storage for the Fallbrook distribution system. The Fallbrook system is fed by the SDCWA through the first and second aqueduct. The amount of

water supplied to the Fallbrook system is controlled by SDCWA through their flow control facilities (FCF's) based on flow requests provided by FPUD. The RMR floats on the distribution system for zones fed by the following SDCWA flow control facilities and can provide water to supply these zones without pumping: Fallbrook 3 (FB3), Fallbrook 4 (FB4), and Fallbrook 6 (FB6). In addition through the Deluz Pump Station, RMR can provide water to feed the Deluz 1 FCF (DL1).

The RMR facility is designed to provide water supply for the RMR service area under two main scenarios:

- Normal operations with the primary supply from the SDCWA FCF's and the RMR floating on the system to meet daily peak demands.
- An emergency condition or planned aqueduct shutdown condition in which the entire RMR service area is fed by RMR.

The peak flow calculated for the future facility under normal operation was 14 cubic feet per second (cfs) (9 million gallons per day (MGD)) Based on a review of the past flow data. To provide an additional level of safety it was assumed that one of the supplies to the RMR zone from the FB6 FCF was not used, which increases the maximum calculated demand to 19 cfs (12.2 MGD). An additional safety factor of 50% was applied to this estimate. This resulted in a design flow of 28.5 cfs, which was rounded up to 18.5 MGD. This design point is based on a conservative approach in which the peak day flow is over twice as high as any observed peak flows.

Although a conservative approach was used to develop the design flow under normal operation, the emergency shutdown of RMR will govern the maximum flow conditions for the facility. This is a condition in which all imported supplies to Fallbrook are disrupted. In order to determine the maximum day flow rate, demands associated with the FCF's distributing water to the service area were determined by reviewing past records of FCF and discussing the maximum demands with FPUD. Based on past data, the maximum day demands for the area were 41 cfs (26.5 MGD). Based on discussions with FPUD staff, it was determined that the demands could reach 54 cfs (34.8 MGD), but the Deluz Pump Station would only be able to provide 4 cfs (2.6 MGD) of the 13 cfs (8.4



MGD) demand associated with this zone. This would result in a maximum day demand from RMR, if there was a full aqueduct shutdown on the historical maximum demand day, of 48 cfs (31.0 MGD). The ratio of the peak flow to maximum day flow was approximately 1.6 based on evaluations of the maximum day demands from FCF data and relating this to peak flow data collected. Using this ratio, the peak demand was 77 cfs (49.7 MGD). However, the design flow under an aqueduct shutdown was limited to 50 cfs (32 MGD) because it is unlikely that there would be a total aqueduct shutdown on the peak day. A summary of the design values are provided in Table 1-1.

**Table 1-1.  
Flow Rate Summary (Design Points in Shaded Cells)**

Flow Condition	Normal Operation	Failure / Aqueduct Shutdown
Peak Flow	28.5 cfs (18.4 MGD) <sup>1</sup>	77 cfs (49.7 MGD)
Max. Day	17.8 cfs (11.5 MGD)	48 cfs (31.0 MGD) <sup>2</sup>
Ave. Day	9.5 cfs (6.1 MGD)	N/A

<sup>1</sup> Rounded to 18.5 MGD for design point

<sup>2</sup> Rounded to 50 cfs (32 MGD) for design point

The approach utilized in this project results in very conservative flow rates for this facility to cover the normal operating condition. A safety factor of 50% was used over the maximum calculated peak flow based on observed values during peak demand months. In addition the facility is designed to provide treatment under a major catastrophic condition in which both aqueduct lines that supply water to San Diego County fail. This is a condition that will result in major supply distribution throughout the county, but the RMR facility will be able to continue to provide fully treated water during these events.

### 1.1.3. UVT Data

UVT measurements for the RMR are limited to data collected during 2007. To supplement the limited data for the RMR, UVT data was gathered from the Skinner

Filtration Plant, which is the SDCWA treatment plant that supplies the RMR. The available UVT data for the Skinner Filtration Plant is based on jar tests performed on the raw water for regulatory compliance. The UVT data is assumed to be conservative compared to the finished water at the plant. Figure 1-1 illustrates the available UVT data.

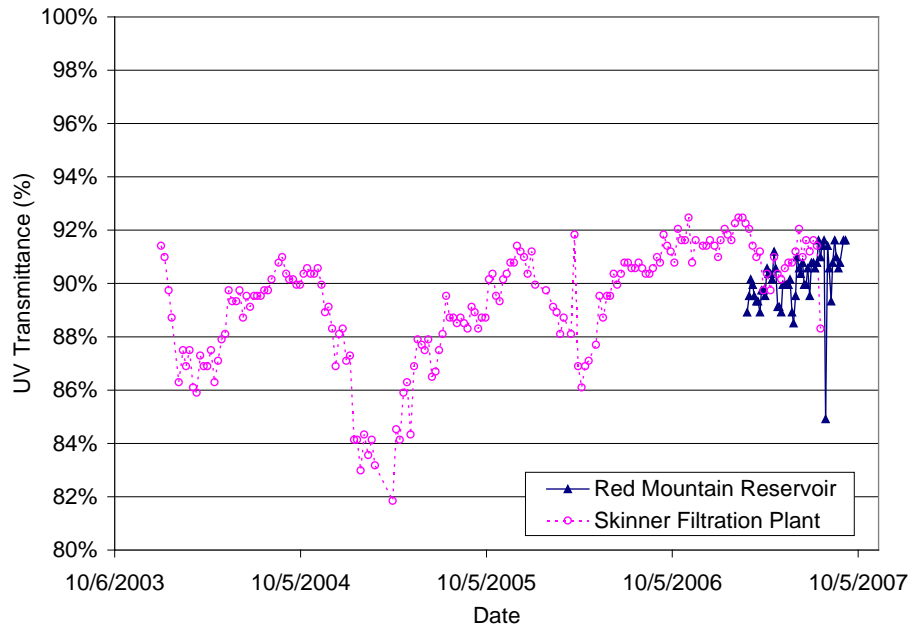

**Figure 1-1: UV Transmittance Data for the RMR and the Skinner Filtration Plant**

#### 1.1.4. Flow and UVT Design Points

The UV reactors will have to meet two flow and UVT design points. The first design point is based on the normal operation peak flow of 18.5 MGD. For normal operation, the lowest measured UVT (i.e., 82%) was selected to be conservative because of the limited UVT data available (Figure 1-2). Under normal operating conditions, a redundant reactor will also be available. The second design point is based on the flow that would be required if both aqueducts were shut down. This design point was based on the max day flow rate for this condition, which is estimated to be 32 MGD. The UVT for this design point was assumed to be the median UVT which is approximately 89% based on the Skinner Filtration Plant data. By selecting conservative UVT and flow rate combinations, the UV reactors will have added flexibility and redundancy during normal

operation when the UVT is above the design minimum UVT and when the flows are below the design flows.

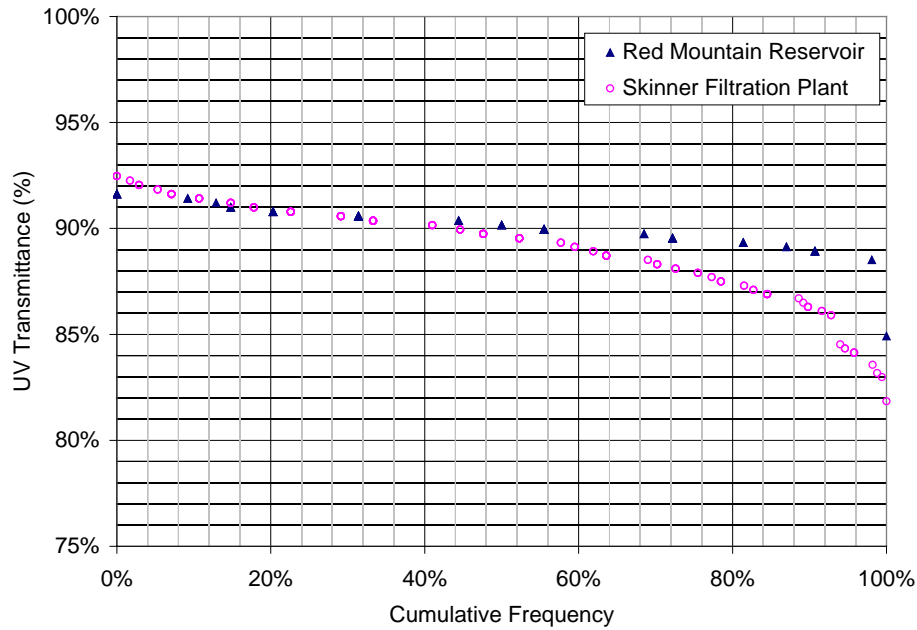

Figure 1-2: UV Transmittance Cumulative Frequency Diagram

## 1.2. Purpose of Memorandum

The LT2ESWTR requires that all reactors be validated to receive inactivation credit with UV disinfection. The purpose of this memorandum is to describe validation fundamentals, summarize UV installations in California, describe FPUD’s approach for reactor validation, and describe methods of performance verification.

## 2. Validation Fundamentals

---

The LT2ESWTR requires that UV reactors be validated using biosimetry in order to receive inactivation credit from the state. Biosimetry is currently the only USEPA accepted method for reactor validation and is defined by the USEPA as

“a procedure used to determine the reduction equivalent dose (RED) of a UV reactor. Biosimetry involves measuring the inactivation of a challenge microorganism after exposure to UV light in a UV reactor and comparing the results to the known UV dose-response curve of the challenge microorganism (determined via bench-scale collimated beam testing).” (USEPA 2006)

A surrogate challenge microorganism is used in place of the target pathogen (e.g., *Cryptosporidium* or *Giardia*) due to costs and safety hazards associated with using the target pathogen. Over the past decade, male-specific-2 bacteriophage (MS2) and *Bacillus subtilis* have been the most commonly used challenge microorganisms. New challenge microorganisms are becoming available that reduce validation biases.

### 2.1. Biosimetry Overview

The UV Disinfection Guidance Manual (UVDGM) describes in detail the biosimetry process, and the Figure 2-1 illustrates the biosimetry process (USEPA, 2006). Biosimetry measures the log inactivation of a challenge microorganism and compares the log inactivation to the challenge microorganism’s dose-response curve, which is determined through bench-scale collimated beam testing. Bench-scale collimated beam tests determine the dose-response curve under ideal hydraulics and UVT conditions. The challenge microorganism log inactivation is converted into a reduction equivalent dose (RED) using the dose-response curve. RED values are specific to the challenge microorganism’s inactivation kinetics and the UV reactor’s dose distribution;

therefore, REDs for different challenge microorganisms can not be directly compared even though they have the same dimensions (i.e.,  $\text{mJ}/\text{cm}^2$ ).

**Figure 2-1: Overview of USEPA Recommended Validation Protocol (USEPA, 2006)**

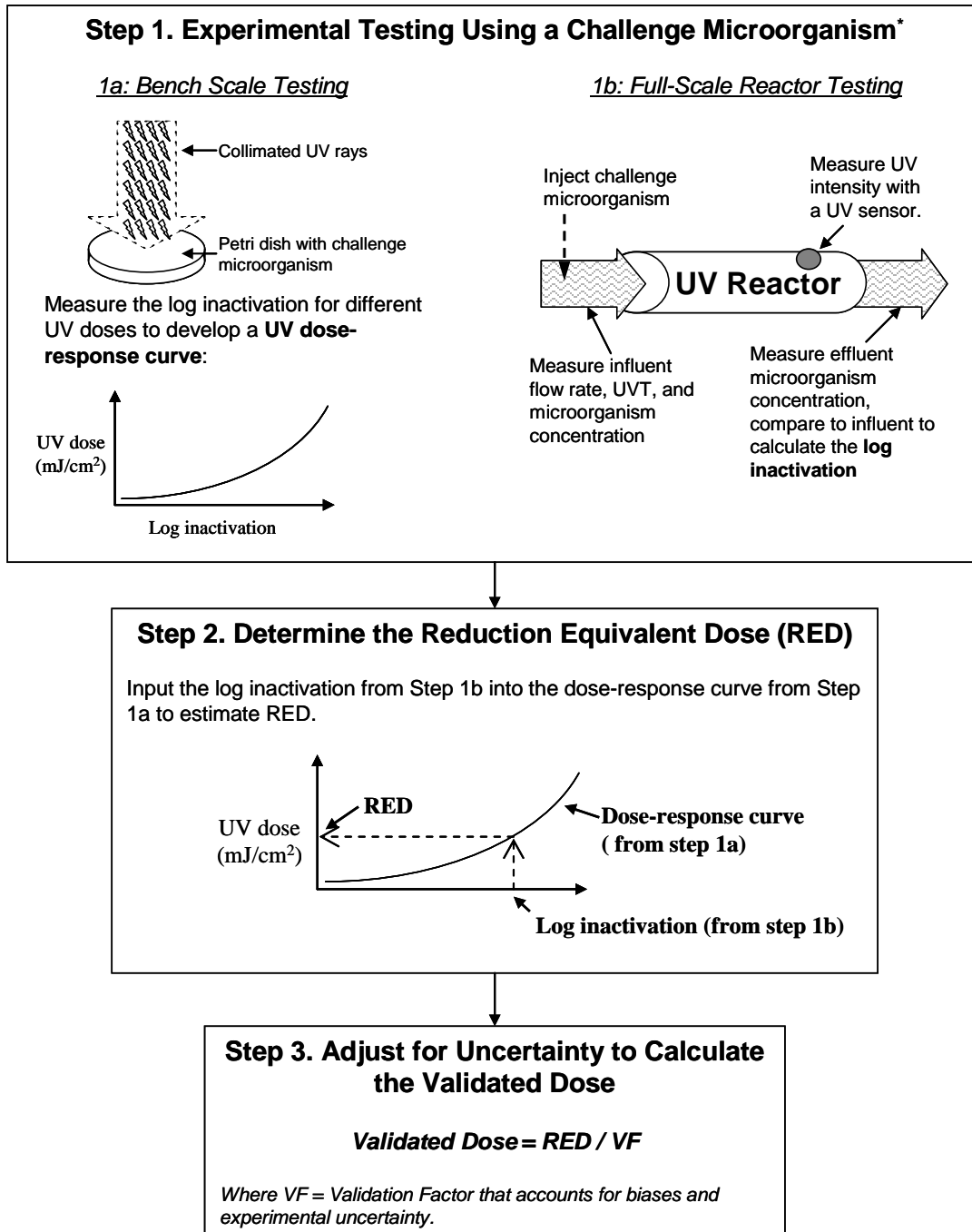

\* Simple representations of testing equipment shown. For more details, see Figures C.1 and 5.2.

Biodosimetry provides disinfection performance assessment (i.e., RED) under specific flow and UVT conditions and describes the performance with one “dose” or RED. However, it can not provide information on the UV reactor dose distribution. The water industry has used the concept of dose (e.g., chlorine residual times contact time) for decades to assess disinfection performance. Therefore, regulatory compliance, equipment specifications, and design and operation of UV facilities currently have been based on dose (i.e., RED).

## **2.2. Limitations of Biodosimetry**

Biodosimetry has limitations from instrumentation and calculation uncertainties and from the use of a challenge microorganism that has different UV inactivation kinetics than the target pathogen.

### **Equipment and Calculation Uncertainties**

The UV sensors that are used to indicate dose delivery have uncertainty associated with their UV intensity measurement and the uncertainty is typically around 20%. In addition, there are uncertainties associated with calculating the collimated beam UV dose-response curve and with calculating the RED. These uncertainties are typically between 20 and 30%. Combining these uncertainties results in a validation uncertainty typically between 20 and 50%.

### **Ramifications of Using a Challenge Microorganism**

The use of a challenge microorganism results in a biased prediction of the UV dose. The bias (i.e., RED bias) is due to the difference in inactivation kinetics between the target pathogen (e.g., *Cryptosporidium*) and the challenge microorganism (e.g., MS2) shown in Figure 2-2 and the dose distribution within the UV reactor. In an ideal UV reactor that only delivers one dose, all of the microorganisms would be exposed to the same dose (Figure 2-3) regardless of their path through the reactor. Therefore, the RED would be the same for the target and challenge microorganism (Table 2-1) in an ideal reactor. However, the RED is not the same for all microorganisms because of the dose distribution that depends on lamp placement, UV intensity distribution (which changes

with UVT), and the hydraulics within the reactor. Biosimetry does not provide information on the dose distribution within the UV reactor.

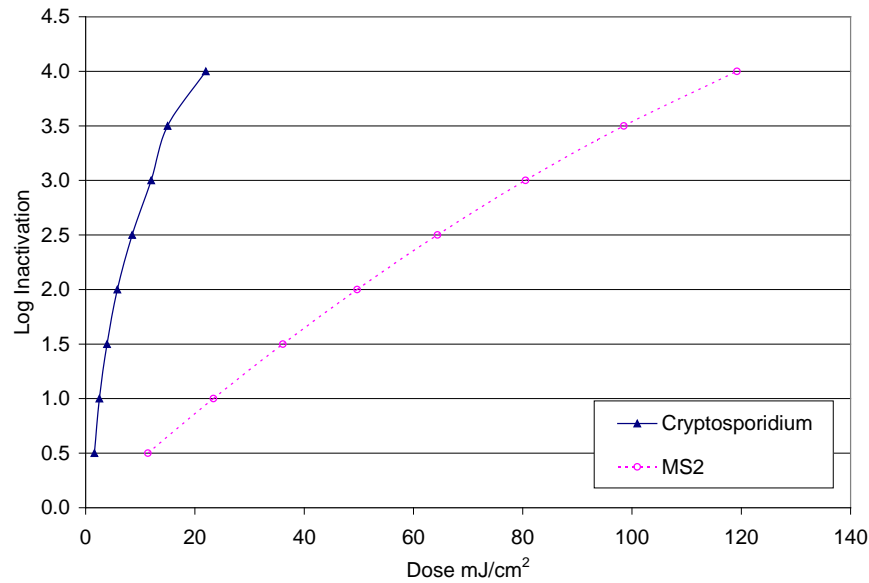

**Figure 2-2: UV Dose-Response Curves for Male-Specific-2 Bacteriophage and *Cryptosporidium***

**Table 2-1.  
Calculated RED Based on Ideal Dose Distribution and UV Dose-Response Curves**

Dose (mJ/cm <sup>2</sup> )	Occurrence Probability (A)	<i>Cryptosporidium</i>		MS2	
		Sensitivity <sup>b</sup> (mJ/cm <sup>2</sup> /log inactivation)	Log Inactivation (B)	Sensitivity <sup>b</sup> (mJ/cm <sup>2</sup> /log inactivation)	Log Inactivation (C)
5	0%	2.8	0	25.0	0
7.5	0%	3.1	0	25.0	0
15	100%	4.5	3.3	21.4	0.7
22	0%	5.8	0	24.4	0
<b>Total Log Inactivation<sup>a</sup> (sum of A*B or A*C)</b>		<b>3.3</b>		<b>0.7</b>	
<b>Sensitivity<sup>b</sup> (mJ/cm<sup>2</sup>/log inactivation)</b>		<b>4.5</b>		<b>21.4</b>	
<b>Calculated RED (mJ/cm<sup>2</sup>)</b>		<b>15</b>		<b>15</b>	

<sup>a</sup>Total log inactivation is the weight average of the log inactivations

<sup>b</sup>Sensitivity is based on the dose-response curves for each microorganism

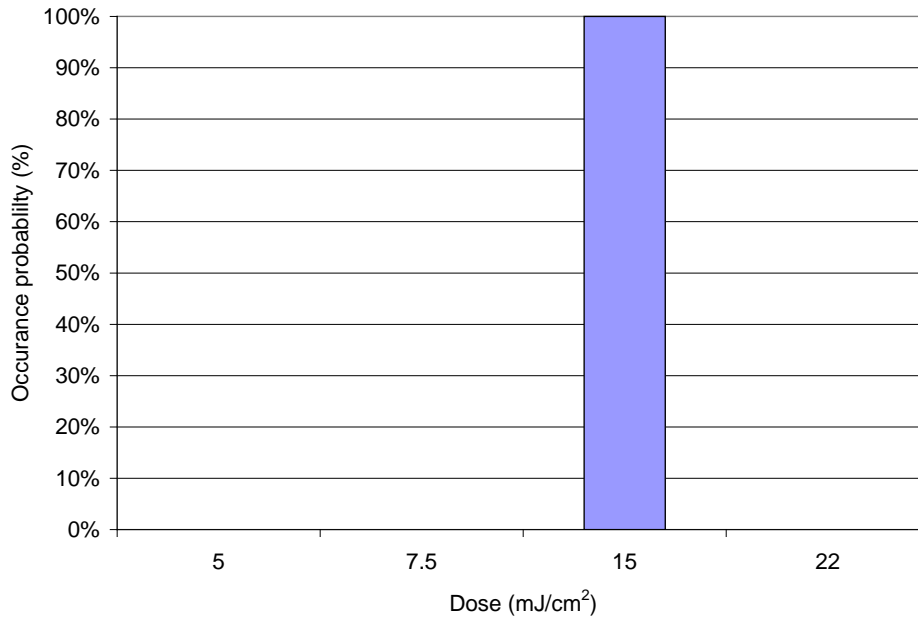

**Figure 2-3: Ideal UV Reactor Dose Distribution**

To illustrate this, consider a hypothetical UV reactor that delivers doses of 5, 7.5, 15, and 22 mJ/cm<sup>2</sup> (Figure 2-4). Based on this dose distribution, the log inactivation would be 3.0-log for *Cryptosporidium* and 0.7-log for MS2 (Table 2-2). The dose-response characteristics of the microorganisms (Figure 2-2) are used to calculate the log inactivation for each dose. The log inactivation is multiplied by the occurrence probability to determine the weighted total log inactivation. The total log inactivation can then be compared to the dose-response characteristics of the microorganism (Figure 2-2) to estimate the RED that would be observed during biosimetry. For this example, the calculated RED would be 12 mJ/cm<sup>2</sup> for *Cryptosporidium* and 15 mJ/cm<sup>2</sup> for MS2. The MS2 RED is approximately 28% greater than the *Cryptosporidium* RED for this example.

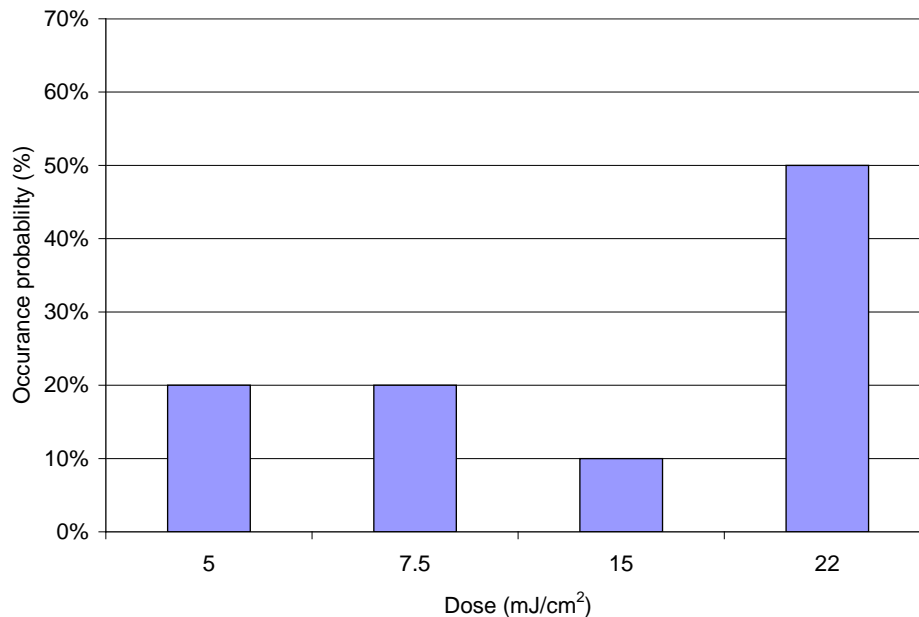

**Table 2-2.**  
**Calculated RED Based on Non-ideal Dose Distribution and UV Dose-Response Curves**

Dose (mJ/cm <sup>2</sup> )	Occurrence Probability (A)	<i>Cryptosporidium</i>		MS2	
		Sensitivity <sup>b</sup> (mJ/cm <sup>2</sup> /log inactivation)	Log Inactivation (B)	Sensitivity <sup>b</sup> (mJ/cm <sup>2</sup> /log inactivation)	Log Inactivation (C)
5	20%	2.8	1.8	25.0	0.2
7.5	20%	3.1	2.4	25.0	0.3
15	10%	4.5	3.3	21.4	0.7
22	50%	5.8	3.8	24.4	0.9
<b>Total Log Inactivation<sup>a</sup> (sum of A*B or A*C)</b>		<b>3.0</b>		<b>0.7</b>	
<b>Sensitivity<sup>b</sup> (mJ/cm<sup>2</sup>/log inactivation)</b>		<b>3.9</b>		<b>21.4</b>	
<b>Calculated RED (mJ/cm<sup>2</sup>)</b>		<b>11.7</b>		<b>15.0</b>	

<sup>a</sup>Total log inactivation is the weight average of the log inactivations

<sup>b</sup>Sensitivity is based on the dose-response curves for each microorganism



**Figure 2-4: Theoretical UV Dose Distribution**

To calculate the RED bias for the hypothetical UV reactor in Figure 2-4, the calculated RED of MS2 is divided by the calculated RED for *Cryptosporidium*. For this example, the RED bias would be 1.28. This example RED bias is comparable to the

RED biases presented in the UVDGM for 3-log *Cryptosporidium* when the UVT is greater than 95 percent since it is a simplistic dose distribution illustration. The dose distribution typically becomes wider as the UVT decreases (depending on UV reactor lamp configuration and power), and the RED bias also increases as the UVT decreases.

### 3. UVDGM Validation Protocol Summary

---

The required doses in Table 3-1 are based on bench-scale testing experiments where the UV dose was closely controlled in the laboratory. The REDs measured during validation cannot be directly compared to the dose tables presented in the LT2ESWTR (Table 3-1) because of the RED bias (as described in Section 2.2).

**Table 3-1.  
UV Dose Requirements (USEPA 2006)**

Target Pathogens	Log Inactivation							
	0.5	1.0	1.5	2.0	2.5	3.0	3.5	4.0
<i>Cryptosporidium</i>	1.6	2.5	3.9	5.8	8.5	12	15	22
<i>Giardia</i>	1.5	2.1	3.0	5.2	7.7	11	15	22
Virus	39	58	79	100	121	143	163	186

#### 3.1. USEPA Method to Addressing Biodosimetry Limitations

To allow for a direct comparison of the measured REDs and the dose table in the LT2ESWTR, the USEPA developed a method to calculate the “validated dose” that account for the biases and uncertainties associated with the validation process. The validated dose is directly compared to the UV dose tables (Table 3-1) to determine inactivation credit achieved. To calculate the validated dose (Equation 1), the challenge microorganism RED is divided by the validation factor (Equation 2). The UVDGM provides tables for calculating the RED bias based on the target pathogen, target log inactivation, UVT, and the sensitivity of the challenge microorganism. The UVDGM also provides detailed guidance on how to calculate the uncertainty of validation factor.

$$\text{Validated Dose} = \text{RED} / \text{VF} \quad \text{Equation 1}$$

where:

- RED = the minimum RED for the UV Intensity Setpoint Approach; or the RED as calculated using the dose-monitoring equation for the Calculated Dose Approach
- VF = the Validation Factor, as calculated using Equation 2

$$\text{VF} = B_{\text{RED}} \times \left( 1 + \frac{U_{\text{val}}}{100} \right) \quad \text{Equation 2}$$

where:

- VF = Validation Factor
- B<sub>RED</sub> = RED bias factor
- U<sub>val</sub> = Uncertainty of validation expressed as a percentage

The 2003 draft version of the UVDGM provided recommended target REDs for various levels of inactivation of the target pathogens. These RED tables (i.e., Tier 1 tables) included safety factor (i.e., it assumed a conservative validation factor) in the RED targets that for the biases and uncertainties associated. In the final 2006 version of the UVDGM, which is recommended by the USEPA, the biases and uncertainties are calculated rather than established by USEPA (as one number), which provides for a more accurate and site-specific calculation of the biases and uncertainties. The Tier 1 tables were also not specific to the challenge microorganism. As discussed in section 2, REDs are specific to the challenge microorganism and cannot be compared to REDs of another microorganism.

The following section provides a brief example calculation of the VF and validated dose.

### 3.1.1. Example Validated Dose Calculation

A WTP has the following design criteria

- Target inactivation of 3-log *Cryptosporidium*
- Design flow rate of 20 MGD
- Minimum UVT of 85%

Based on the dose tables in the LT2ESWTR, the WTP must provide a dose of 12 mJ/cm<sup>2</sup>. A UV reactor is selected that was validated for the selected design criteria. During the validation, the challenge microorganism was MS2 and had a sensitivity of 19 mJ/cm<sup>2</sup>/log inactivation. Based on the Table G.3 in the UVDGM (page G-4), the RED bias is 2.01. Based on the other uncertainties of the validation process, U<sub>Val</sub> was calculated to be 25 percent. The VF is calculated to be 2.5 using Equation 2. Given the required dose of 12 mJ/cm<sup>2</sup>, to receive credit for 3.0-log inactivation of *Cryptosporidium* the validation testing must prove the UV reactor achieves an MS2 RED of at least 30 mJ/cm<sup>2</sup> under design conditions.

### 3.2. UVDGM Method for Addressing Hydraulic Differences

The UVDGM recommends that the inlet and outlet piping in at the UV facility should result in the dose being greater than or equal to what was measured during validation. The UVDGM recommends three approaches to ensure the hydraulics are adequate to provide a better dose delivery.

- Minimum of 5 pipe diameters of straight pipe upstream of the UV reactor. The five pipe diameters should be in addition to any length of straight pipe upstream of the UV reactor during validation. During validation testing, the inlet piping to the reactor consists of either a single 90-degree bend, a “T” bend, or an “S” bend, followed by a length of straight pipe if necessary.
- Identical inlet and outlet conditions. The inlet and outlet piping configuration should be identical for 10 pipe diameters upstream of the reactor and 5 pipe diameters downstream of the UV reactor.
- Velocity profile measurements. Velocity of the water should be within 20% of the theoretical velocity for both the validation and installation.

The UVDGM also states that CFD modeling of the inlet and outlet conditions may be used to assess if the dose delivery at the water treatment plant is better than during validation for given flow rates, UVTs, and lamp output if approved by the state.

## 4. California UV Disinfection Technology Experience

The state of California currently has several water treatment plants that use UV disinfection (Table 4-1). Of the plants receiving inactivation credit, one plant (West Valley Water) has been required to do “spot check” validations once the UV reactors are installed, and one plant (North Tahoe) completed on-site validation. The purpose of the “spot check” validation at West Valley Water was to verify that the reactors could meet the target MS2 RED under the design conditions. The testing also verified the power consumption and headloss through the reactors. The “spot check” validation showed that the UV reactors, which were installed based on the UVDGM installation recommendations, met all of the performance requirements (Landis et al, 2007).

**Table 4-1.  
UV Installations in California**

<b>Location</b>	<b>Installation Year</b>	<b>Performance Verification</b>	<b>Received Credit from State</b>
North Tahoe, CA	2002	Full on-site validation	Yes
West Valley Water District, CA	2004	“spot check” validation	Yes
Perris, CA	2005	None	Yes
Trimark Communities WTP, Mountain House, CA	2006	Velocity profile	In trial period before credit is received
Bear Gulch WTP, Atherton, CA	2006	Velocity profile	Pending approval
Groveland, Yosemite, CA	2006	Velocity profile	Pending approval
Constellation Power, Victoriaville, CA	2007	None	Not seeking credit
City of Tracy, John Jones WTP, CA	2007	CFD modeling	In trial period before credit is received

## 5. FPUD Validation and Performance Demonstration Approach

---

The design of the FPUD UV facility will meet all of the LT2ESWTR requirements and UVDGM recommendations. The UVDGM validation protocol and design recommendations in the UVDGM are based on over 6 years of research with significant input from international UV experts, regulators, water utilities, consultants, and UV manufacturers. The UVDGM also builds upon the experience of other validation protocols, such as the Deutscher Verein Des Gas-und Wasserfaches e.V (DVGW) standards that have been used for UV reactor validation and installation in Germany for over 10 years.

### 5.1. Approach for UV Facility Design and Validation

As described in Section 1, conservative pathogen targets, flows, and UVTs have been selected for the basis of the UV facility design. Specifically, the conservative flow and UVT design points provide extra capacity for FPUD during normal operation (i.e., not aqueduct shutdown emergency) given that the minimum UVT (over a 4 year period) was selected and the flows include a 50% safety factor.

Only pre-validated UV reactors will be installed for the UV facility, and the procurement documents will specify that the UV reactor must have been validated in accordance with the validation protocol in the UVDGM (USEPA 2006). Reactor validation reports will be required to be submitted with all bid proposals. The validation reports will be used to ensure that the UV reactors were validated under all of the selected design conditions and that all validation protocol and quality assurance and quality control requirements were met before the UV reactors are purchased.

The UVDGM recommends that the design of the UV facility should include a minimum of 5 pipe diameters of straight pipe upstream of the UV reactors. Adding 5 pipes diameters of straight pipe should result in equal or better hydraulics than what was validated. The current FPUD UV facility design includes 5 pipe diameters upstream of the UV reactors.

## 5.2. Logistical Issues for On-site Validation at RMR

There are significant logistical hurdles to overcome if FPUD is required to perform “spot check” validation of the installed UV reactors. “Spot check” validation could result in the need to dispose of large volumes of water. Approximately 200,000 gallons of waste water would be created in approximately 30 minutes for each test condition at the design flow rate. The FPUD UV facility is located at the discharge of an uncovered reservoir, and currently there are no disposal options available on-site. The sanitary sewer and nearest creek could not handle this volume of water in such a short time period.

On-site validation used to be the standard for UV reactor validation before the UVDGM was finalized. The current trend in the water industry is UV facility design and regulatory approval based on off-site validation (e.g., Perris, CA and Seattle, WA), which is what is recommended for FPUD. On-site validation has several logistical issues that are eliminated with off-site validation. These include but are not limited to ensuring proper mixing of the challenge microorganism and UV absorbing chemical and public misconceptions and fears of bringing the challenge microorganism on-site and spiking into a drinking water disinfection facility.

## 5.3. Performance Demonstration

FPUD is committed to protecting public health and providing safe water to its customers. Two other methods of verifying performance and protection of public health could be completed instead of “spot check” validation, which include CFD modeling and a trial operation period prior to receiving inactivation credit.

CFD modeling can show that the installed UV reactors have hydraulics and dose delivery that is equal to or greater than during validation. The CFD modeling will be performed by the UV manufacturer as part of the UV reactor procurement process. The UV manufacturers have already completed CFD modeling on the reactors that would be installed at the FPUD UV facility. The CFD modeling, for the Calgon Carbon Corporation UV reactor, shows that the MS2 REDs achieved with ideal hydraulics upstream of the UV reactor are approximately 3% greater than what was measured during



validation. This indicates that the hydraulics during the validation testing were worse than what would occur once the UV reactor is installed. The dose equation used by the reactors is based on the validated doses measured during validation. The improved hydraulics will result in conservative calculations of the validated dose.

Operating the FPUD UV facility during a trial period can prove that the UV reactors can operate reliably and minimize off-specification water. During this time, FPUD can perform regular calibration checks on the UV sensors and UVT analyzer to ensure that their calibration can be maintained during normal operation. By ensuring the calibration of these key components, the accuracy of the validated dose calculation can be maintained. In addition, off-specification water can be closely monitored to confirm that the design criteria were appropriate and to develop methods to reduce off-specification water based on the trial period operation.

By performing CFD modeling and performing a trial period of more intensive monitoring, California Department of Public Health can be confident that FPUD UV Facility is meeting LT2ESWTR requirements and protecting public health.

## 6. Summary and Conclusions

---

FPUD currently operates RMR, a 440 million gallon uncovered reservoir, that stores treated water purchased from the SDCWA. FPUD is currently designing a facility to meet the requirements of the LT2ESWTR with a multi-barrier disinfection approach incorporating UV disinfection for *Giardia* and *Cryptosporidium* inactivation and free chlorine for virus inactivation. To receive inactivation credit with UV disinfection, the LT2ESWTR requires that the UV reactors be validated.

Conservative pathogen targets, flows, and UVTs have been selected for the basis of the UV facility design. Specifically, the conservative flow and UVT design points provide extra capacity for FPUD during normal operation (i.e., not an aqueduct shutdown emergency) given that the minimum UVT (over a 4 year period) was selected and the flows include a 50% safety factor. The design is also based on providing 3-log *Cryptosporidium* inactivation which provides additional flexibility to meet future water treatment goals at minimal additional costs.

The design of the FPUD UV facility is based on the use of pre-validated UV reactors. The selected reactor will be validated based on the UVDGM protocol and for all of the operational and design conditions of the FPUD UV facility. If pre-validated UV reactors are to be used, the UVDGM recommends that the inlet and outlet piping of the UV reactors be selected to ensure that the dose delivery once installed is equal to or better than during validation. To meet this recommendation, a minimum of five pipe diameters of straight pipe will be installed upstream of the UV reactor. This will create better hydraulics and provide better dose delivery than during validation.

Biodosimetry testing results in the calculation of a RED that is specific to the challenge microorganism and cannot directly be compared to the target pathogen (e.g., *Cryptosporidium*). To allow for a direct comparison of measured REDs, the USEPA developed a method to calculate the “validated dose” that account for the biases and uncertainties associated with the validation process. The validated dose is directly

compared to the UV dose tables in the LT2ESWTR to determine inactivation credit achieved.

The water industry is currently moving away from on-site validation of UV reactors due to logistical and other related issues. The USEPA has approved the use of off-site validation and has developed specific performance monitoring and control approaches to ensure that the UV reactors performance is equal to or better than what was validated. A “spot check” validation in California has previously shown that following the UVDGM recommendations resulted in reactor performance that is equal to or better than what was validated. The UVDGM approved approach of off-site validation has been used at several utilizes including Perris, CA and Seattle, WA. This is the approach that is being recommended for the FPUD UV facility.

“Spot check” validation would be problematic at the FPUD UV facility. Unlike the West Valley Water UV facility, the FPUD UV facility does not have a method to dispose of any test water due to lack of treatment on-site, no sanitary sewer, and the volume of water that would be generated during testing.

Several other steps could be taken instead of “spot check” validation to show that public health and safety are being protected. CFD modeling can show that the installed UV reactors have hydraulics and dose delivery that is equal to or greater than during validation. Previous CFD modeling has shown that, five pipe diameters of straight pipe prior to the UV reactor creates better dose delivery (e.g., a 3% increase in calculated RED was calculated with straight pipe prior to the Calgon Carbon UV reactor).

The UV facility is being designed to minimize the creation of off-specification water. Prior to receiving inactivation credit, the UV facility could also be operated on a trial basis to ensure that the design parameters can be met and off-specification water can be avoided. During this trail period additional O&M tasks and close monitoring of off-specification water can be completed to ensure the reactor is operating properly.

## 7. References

---

Landis, H., Sikorski, K., Shirolkar, A., and Foellmi, S. 2007. Design, Testing and Operation of the West Valley Water's Districts UV Facility. Presented at World Congress on Ozone and Ultraviolet Technologies. Los Angeles, CA, August 27 – 29

United States Environmental Protection Agency. 2006. Ultraviolet Disinfection Guidance Manual for the Final Long Term 2 Enhanced Surface Water Treatment Rule. Office of Water, Washington DC.



Covina Irrigating Company

---

# UV/Chloramination at the Temple WTP

## Preliminary Design Report

June 2008

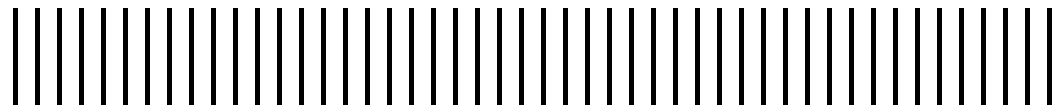

Report Prepared By:

**Malcolm Pirnie, Inc.**

8001 Irvine Center Drive  
Suite 1100  
Irvine, CA 92618  
949-450-9901

5324002

**MALCOLM  
PIRNIÉ**

Contents

<b>1. Introduction</b>	<b>1-1</b>
1.1. Disinfection Goals .....	1-1
1.2. Report Organization .....	1-2
<b>2. Existing Conditions</b>	<b>2-1</b>
<b>3. Tracer Study</b>	<b>3-1</b>
3.1. Study Methods .....	3-1
3.2. Results .....	3-2
3.3. Discussion .....	3-6
3.4. Conclusions .....	3-8
<b>4. Disinfection Profiling and Benchmarking</b>	<b>4-1</b>
4.1. Methods to Construct the Disinfection Profile and Benchmarking .....	4-1
4.2. Disinfection Profile .....	4-1
4.3. Disinfection Benchmark .....	4-4
4.4. Temple WTP Turbidity and Coliform Data .....	4-5
4.5. Predicted Inactivation Levels after UV/Chloramine Retrofit .....	4-6
4.6. Discussion .....	4-7
4.7. Conclusions .....	4-7
4.8. References .....	4-8
<b>5. Basis of Facility Design</b>	<b>5-1</b>
5.1. Treatment Process Hydraulics .....	5-1
5.2. Basic Design Assumptions .....	5-2
<b>6. Chemical Facilities</b>	<b>6-1</b>
6.1. Chemical Facility Overview .....	6-1
6.2. Storage Tank Design .....	6-2
6.3. Containment Area .....	6-4
6.4. Metering Pumps .....	6-4
6.5. Sodium Hypochlorite Transfer Pumps .....	6-5
6.6. Additional Application Points .....	6-5
<b>7. UV Facility</b>	<b>7-1</b>
7.1. Integrating UV Disinfection into the Treatment Process .....	7-1

7.2. Key Design Parameters .....	7-1
7.2.1. Target Pathogen and UV Dose .....	7-2
7.2.2. Flow Rate .....	7-2
7.2.3. UV Transmittance.....	7-3
7.2.4. Fouling/Aging Factor .....	7-3
7.2.5. Off-Specification Requirements and Power Quality .....	7-3
7.2.6. Lamp Type .....	7-4
7.2.7. Validation Considerations.....	7-5
7.3. Facility Layout .....	7-5
<b>8. Other Improvements</b> .....	<b>8-1</b>
8.1. Grit Chamber.....	8-1
8.2. Recycle Piping and Pumping .....	8-1
8.3. High Service Pump Station .....	8-1
<b>9. Site Design</b> .....	<b>9-1</b>
9.1. Site Design Civil .....	9-1
<b>10. Design Specialties</b> .....	<b>10-1</b>
10.1. Introduction .....	10-1
10.2. Structural.....	10-1
10.2.1. General.....	10-1
10.2.2. UV Building.....	10-1
10.2.3. Chemical Containment Area and Canopy.....	10-2
10.3. Architectural .....	10-2
10.4. Instrumentation and Control.....	10-2
10.4.1. Control System Philosophy/System Architecture.....	10-2
10.4.2. Hardware and software concept/configuration.....	10-3
10.4.3. Preliminary Control Strategies .....	10-4
10.5. Electrical.....	10-16
10.6. HVAC .....	10-17
10.7. Plumbing/Fire Suppression .....	10-17
10.7.1. Utility Water and Drainage .....	10-17
10.7.2. Fire Suppression .....	10-18
<b>11. Impact to Existing Facilities</b> .....	<b>11-1</b>
11.1. Impacts to Existing Facilities.....	11-1
<b>12. Permitting</b> .....	<b>12-1</b>

## List of Tables

Table 3-1. Tracer Study for the Temple WTP .....	3-6
Table 3-2. Baffling Factors for the Temple WTP .....	3-7
Table 4-1. Critical Periods for Existing Disinfection Practice .....	4-4
Table 4-2. Projected Log Inactivation of Virus in the Temple WTP Filter Section .....	4-7
Table 5-1. Design capacity of high service pumps .....	5-1
Table 5-2. Minimum Level of Activation for Proposed UV Facility .....	5-3
Table 6-1. Chemical Facilities Design Criteria .....	6-2
Table 6-2. Storage Tank Design Parameters .....	6-3
Table 6-3. Sodium Hypochlorite Requirements .....	6-4
Table 6-4. Aqueous Ammonia Requirements .....	6-4
Table 7-1. Key Design Parameters for the UV Disinfection Facility .....	7-2
Table 7-2. UV Lamp Comparative Advantages .....	7-4
Table 10-1. Building Classification Summary .....	10-2
Table 10-2. Utility Water Demand .....	10-17

## Table 10-3. Fire Flow Demand

10-18List of Fi

Figure 3-1: Tracer Study of Filter Basin at 95% Max Flow .....	3-3
Figure 3-2: Tracer Study of Filter Basin at 50% Max Flow .....	3-4
Figure 3-3: Tracer Study of Sedimentation Basin at 95% Max Flow .....	3-4
Figure 3-4: Tracer Study of Sedimentation Basin at 50% Max Flow .....	3-5
Figure 3-5: Tracer Study of Flocculent Basin at 95% Max Flow .....	3-5
Figure 3-6: Tracer Study of Flocculent Basin at 50% Max Flow .....	3-6
Figure 3-7: Filter Basin Layout .....	3-8
Figure 4-1: Profiling Data from November 2004 to October 2005 .....	4-3
Figure 4-2: Profiling Data from November 2005 to October 2006 .....	4-3
Figure 4-3: Profiling Data from November 2006 to October 2007 .....	4-4
Figure 4-4: Log <i>Giardia</i> Benchmark for three years ending October 2007 .....	4-5
Figure 4-5: Influent Turbidity and Coliform Counts .....	4-6
Figure 5-1: Proposed Hydraulics with UV/Chloramine .....	5-2

## List of Appendices

Appendix A .....	Preliminary Design Drawings
Appendix B .....	Opinion of Probable Construction Cost



# 1. Introduction

---

Covina Irrigation Company (CICo) owns and operates the William B. Temple Water Treatment Plant (Temple WTP) located in the City of Glendora. The treatment plant employs a conventional surface water filtration process and has a total flow capacity of 12.5 million gallons per day (MGD). The primary sources of water for the Temple WTP are the Morris Reservoir from the nearby San Gabriel Mountains and water from the State Water Project (SWP).

SWP water originates north of the Sacramento-San Joaquin Delta and is notorious for containing high levels of naturally occurring organic material (NOM). Water high in NOM, when treated with free chlorine, will create trihalomethanes (THMs) and disinfectant by-products (DBPs). DBPs and THMs are regulated by the U.S. Environmental Protection Agency (USEPA) and the California Department of Public Health (CDPH). Thus, as Temple WTP continues to predominately treat SPW, it will not be able to reliably comply with the Stage 1 and Stage 2 Disinfectants/Disinfectant By-Products Rule (D/DBPR) using free chlorine as a disinfectant.

In order to continue to comply with the Stage 1 and Stage 2 D/DBPR, CICo must change the practice of free chlorination at the Temple WTP. A compliance strategy assessment was conducted and UV/chloramination was the option chosen. Preliminary designs were prepared to implement the UV/chloramination. This Preliminary Design Report (PDR) considers and evaluates regulatory and monitoring requirements, site-specific requirements and existing facilities, safety considerations, equipment selection and sizing, instrumentation and controls, and permitting.

## 1.1. Disinfection Goals

As the Temple WTP increases its supply from SWP, treatment will be needed to comply with the current Stage 2 Disinfection Byproduct (DBP) Rule. CICo will treat SWP water to achieve 4-log virus, 3-log *Giardia*, and 2-log *Cryptosporidium* inactivation. The required 2-log *Cryptosporidium* inactivation is currently provided via filtration. Since changes are not being made to the existing filters, the WTP will continue to provide the required 2-log *Cryptosporidium* inactivation. Free chlorine is currently added at the beginning of the WTP and is used to achieve *Giardia* and virus inactivation. To minimize DBP formation the primary chlorine addition point will be moved downstream of the flocculation/sedimentation basins and ammonia will be added following filtration to form chloramines, which will decrease the *Giardia* and virus inactivation achieved. UV disinfection will be utilized to achieve 3-log *Giardia* inactivation. UV disinfection for 4-log virus reduction is not cost-effective; therefore, virus inactivation will be achieved with the use of free chlorine through the filters, which will also provide a multiple disinfection barrier.

The Stage 2 DBP Rule will require utilities to transition from meeting system-wide running annual averages for total trihalomethanes (TTHMs) and five haloacetic acids (HAA<sub>5</sub>) to meeting LRAAs. The Stage 2 DBP Rule requires that LRAAs be less than 80 µg/L for TTHMs and less than 60 µg/L for HAA<sub>5</sub>. CCo currently maintains a free chlorine residual throughout the Temple WTP and distribution system. To minimize the formation of DBPs, Temple WTP will convert to using chloramines after the required free chlorine contact time and move the chlorine additional point downstream of flocculation/sedimentation to reduce free chlorine contact time.

## 1.2. Report Organization

This project consists of two major systems, the UV facility and Chemical (chlorine and ammonia) facilities. The remaining sections of this Preliminary Design Report (PDR) provide some background information for the proposed facilities and address design considerations.

## 2. Existing Conditions

---

The Temple WTP has a permitted capacity of 12.5 MGD and consists of two identical treatment trains that run in parallel. Each train uses the following major process units: coagulant feed and rapid mix, flocculation, sedimentation, filtration (automatic backwash filter), and disinfection. Since the plant does not have a clearwell, contact time (CT) is determined by disinfection through each treatment process and time in the transmission line to the first retail agency.

### **Chemical Feeds**

CICo is currently using polyaluminum chloride for coagulation, and stores it in bulk storage tanks at the northeast corner of the plant, shielded from direct sunlight. The polyaluminum chloride is fed via two diaphragm metering pumps to the flow in the rapid mix chamber. The pumps are flow paced, based on the plant influent flow meter. . During normal operating conditions of turbidity less than 10 NTU, polyaluminum chloride is fed at a dosage of approximately 5 to 8 mg/L.

Sodium hypochlorite is currently used to provide chlorine for disinfection. This chemical is stored in the northeast corner of the plant in 6,500 gallon bulk storage tanks, shielded from direct sunlight. Two diaphragm metering pumps are used to dose the chemical to the flow in the rapid mix chamber, and two diaphragm metering pumps are used to inject hypochlorite immediately downstream of the filters. As with the coagulant, sodium hypochlorite is flow-paced, so dosing is proportional to the plant influent flow rate. When source waters contain turbidities of less than 10 NTU, sodium hypochlorite is typically fed at a dosage of 2 to 4 mg/L.

### **Flash Mixing**

The rapid mix basin is a cast-in place concrete structure with a working volume of approximately 1,000 ft<sup>3</sup>. A pump diffuser is used to achieve mixing. Immediately upstream of the rapid mix basin is an influent flow control structure that contains the influent flow control valve. This valve is automatically adjusted based on water level in the filter effluent channel to control influent flow rate to match system demand.

### **Flocculation**

Two flocculation basins, each with a volume of 118,500 gallons, operate in parallel to one another. Coagulated raw water from the rapid mix structure flows into an influent distribution channel that distributes flow between the two parallel flocculation basins. In each basin there are paddles that are held in place by a stationary arm. A variable speed drive is used to optimize mixing for various flow rates. The theoretical detention time through the basins is 27 minutes at design flow (6.25 mgd per basin).

### **Sedimentation**

Temple WTP has two rectangular sedimentation basins, 440,000 gallons each. The theoretical detention time is 101 minutes at design flow (6.25 mgd per basin). Settled sludge is removed from each basin by cross collectors, and then discharged to the Los Angeles County Sanitation District's sewer.

### **Filtration**

Water leaves the sedimentation basins and enters a filtration building. Flow is directed to two central channels which independently feed the two automatic backwash filters. Flow is distributed through inlet ports over the filter bed. Each filter bed contains 180 cells which are divided by porous under-drains. Filter to waste is used to ensure severe turbidity breakthrough does not occur.

The automatic backwash filters are shallow-bed type filters with approximately 15 inches of sand. The filters use a backwash system that is mounted on a traveling bridge and controlled either by time or headloss across the filter. Each filter has a surface area of approximately 1,760 ft<sup>2</sup> and a loading of 2.5 gpm/ ft<sup>2</sup> at design flow.

### **Disinfection**

Liquid sodium hypochlorite (12.5% chlorine) is used for disinfection as described above. The rate of chlorine addition at the rapid mixer is flow paced, with a typical dose of 2-4 mg/l.

Plant effluent is continuously measured for free chlorine residual immediately downstream of the filters. If the chlorine concentration is too low, chlorine is automatically added to the plant effluent downstream of the filters.

A chlorine residual of 1-1.5 mg/L is maintained immediately downstream of the Temple WTP. Most of the chlorine is fed to the rapid mix structure. The water exerts a chlorine demand of 1-1.5 mg/L through the plant. The dosage added downstream of filtration is usually between 0.2 and 0.5 mg/L in order to maintain the target residual of 1-1.5 mg/l leaving the WTP.

3-log *Giardia* and 4-log virus removal must be provided from the plant. The filters are given credit for 2-log *Giardia* and 1-log virus removal. Therefore, the remaining 1-log and 3-log removal for *Giardia* and virus, respectfully, must be provided via inactivation. When the source water has elevated turbidity, the plant is required to achieve an additional log inactivation of *Giardia* and virus through inactivation, so a total of 2-log *Giardia* is required.

## 3. Tracer Study

---

Tracer studies were conducted at the Temple WTP to investigate the potential for optimizing disinfection practices using the current facilities. This optimization could improve disinfection efficiency and accomplish the following:

- Increase the margin of safety that the WTP achieves during disinfection of challenged source water,
- Demonstrate the capability of the basins to provide primary disinfection as a means of future DBP regulatory compliance, using a chlorine/chloramines disinfection strategy,
- Potentially reduce operating costs related to chemical addition.

### 3.1. Study Methods

The following methods and materials were used to conduct the tracer studies.

#### Unit Processes Tested

The Temple WTP has two symmetrical units for each process:

- Flocculation Basin
- Sedimentation Basin
- Filter Basin

The two units for each process are identical in construction and dimensions. They are either located North or South of the center line. They have identical hydraulic properties so the tracer studies can be conducted on either side. Because of this flexibility, the plant staff was able to maintain flow condition without much disruption of the plant operation.

#### Flows

Two flows were tested: 50% and 95% of current rated capacity. The normal peak flow was estimated to be 8700 gpm for the total plant. Each side of the plant can process up to 4350 gpm of product water. In all studies, the flows were maintained at 4150 gpm and 2150 gpm for the 95% and the 50% flow conditions, respectively.

The treatment plant is configured for flow control at the raw water influent and pressure control at the product water effluent by plant staff. The balance of the effluent or demand and the influent or supply can be maintained by tracking a constant level in the effluent channel of the filters. Through control of the influent flow control valve to maintain this level, and allowing the effluent pumps to maintain system pressure, flow could be controlled to within 5% during the test periods.

### Tracer Compound

The compound used to track and simulate the flow of water was NSF-approved hydrofluosilicic acid ( $\text{H}_2\text{SiF}_6$ ), which dissociates into the fluoride anion.

### Method of Addition

The hydrofluosilicic acid was added as a slug-dose at the head of the unit process being tested. The tracer was added on a volumetric basis that was designed to produce a fluoride concentration that was easily and accurately measurable, but that after dilution with the effluent of the other side of the plant was close to the fluoride MCL.

### Monitoring

Fluoride concentrations were monitored three different ways in an effort to accurately and completely capture as much of the tracer mass in a timely fashion. More than 91% of the mass was recovered. The three analytical methods were:

1. Real-time ion specific electrode (ISE) analysis was used to guarantee that the leading edge of the tracer plume was captured and to assess if the mass balance was complete and the test could be terminated. Data were collected every minute, so frequently that ionic strength buffer use was not practical. Therefore, the ISE results were used to identify the leading edge and peak concentrations, whereupon samples were collected for analysis using more accurate methods.
2. Hach SPADNS colorimetric method.
3. Periodic (2 samples per test) confirmation by an approved laboratory (Weck Laboratories, City of Industry, CA).

The Hach method and lab analyzed samples were used to calibrate the ISE results using a least-squares curve fitting (polynomial) technique (Numerical Methods for Engineers, Chapra and Canale, 1988), so that an accurate mass balance could be computed. ISE results varied from test to test due to the presence of interfering ions, primarily from the effect of coagulant addition and its presence in the flocculation and sedimentation basins.

## 3.2. Results

Breakthrough curves are presented for seven individual tracer tests (Figures 3-1 to 3-7), showing the analytical results from all three methods of fluoride analysis. Three tracer tests were conducted at 95% of the peak flow, and the other three were at 50% of the flow. The test on the filter at 95% flow was repeated to ascertain the hydraulic properties of the filter.

The “Equivalent Step Dose Concentration” or  $C/C_o$  (second Y axis) is a method of presenting the cumulative mass of tracer observed or recovered as the tracer test proceeds in time. A spreadsheet estimate of the area under the breakthrough curve (using trapezoidal rule numerical integration, Chapra and Canale, 1988) was used to determine the time when  $C/C_o = 10\%$  (T10), mass balance, and baffling factor (ratio of T10 to the

theoretical residence time, see Tables 3-1 and 3-2). The T10 can also be determined graphically by examination of the curve.

Figure 3-1: Tracer Study of Filter Basin at 95% Max Flow, Duplicate

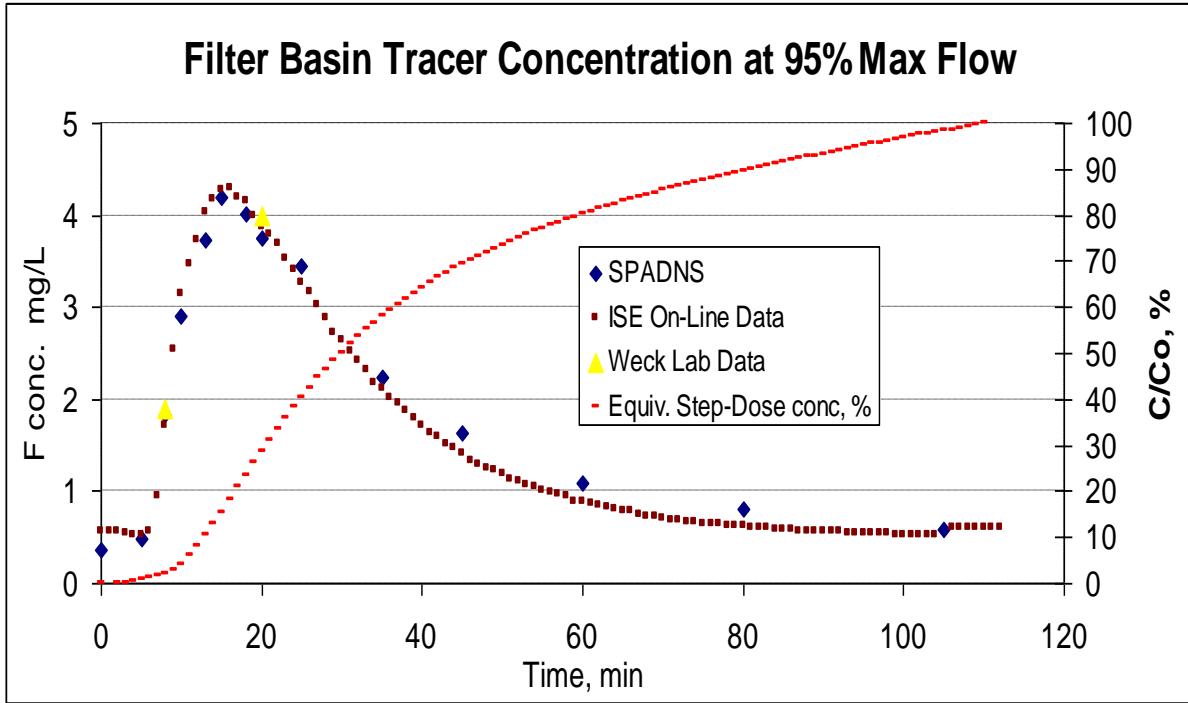

Figure 3-2: Tracer Study of Filter Basin at 50% Max Flow

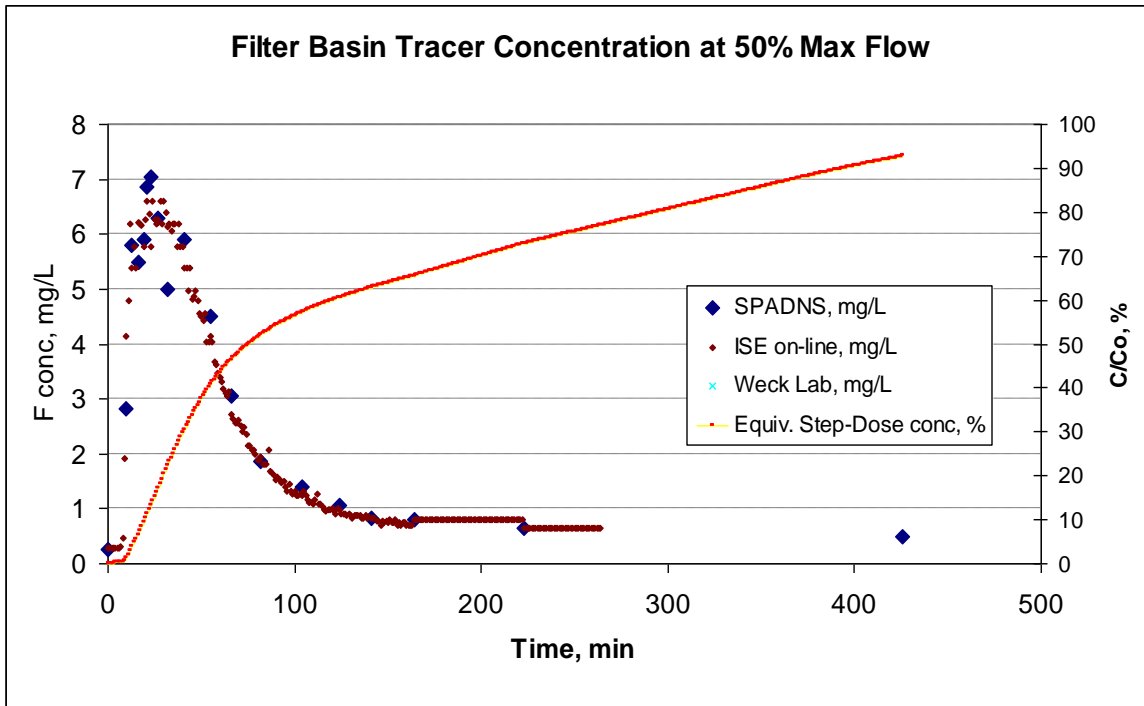

Figure 3-3: Tracer Study of Sedimentation Basin at 95% Max Flow

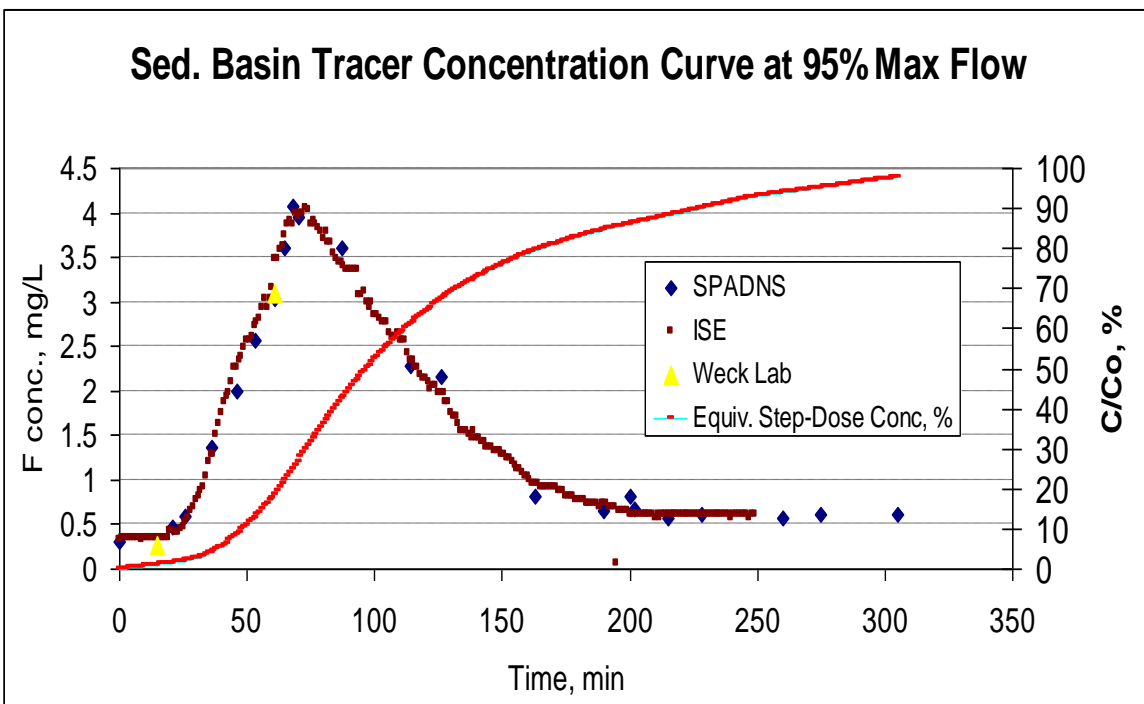



Figure 3-4: Tracer Study of Sedimentation Basin at 50% Max Flow

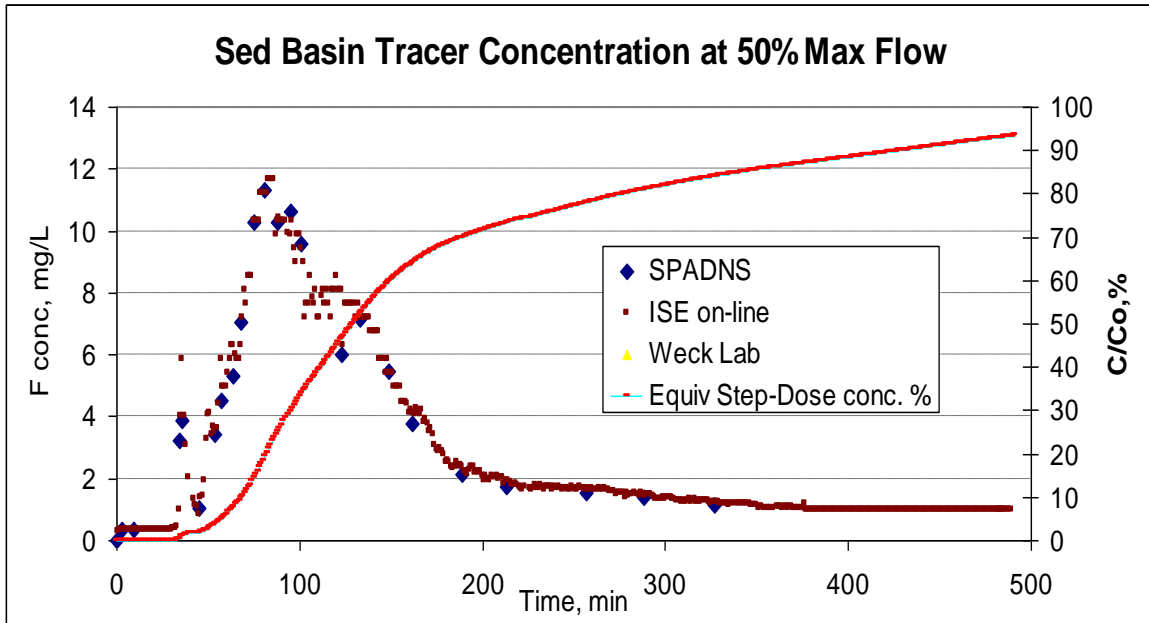

Figure 3-5: Tracer Study of Flocculent Basin at 95% Max Flow

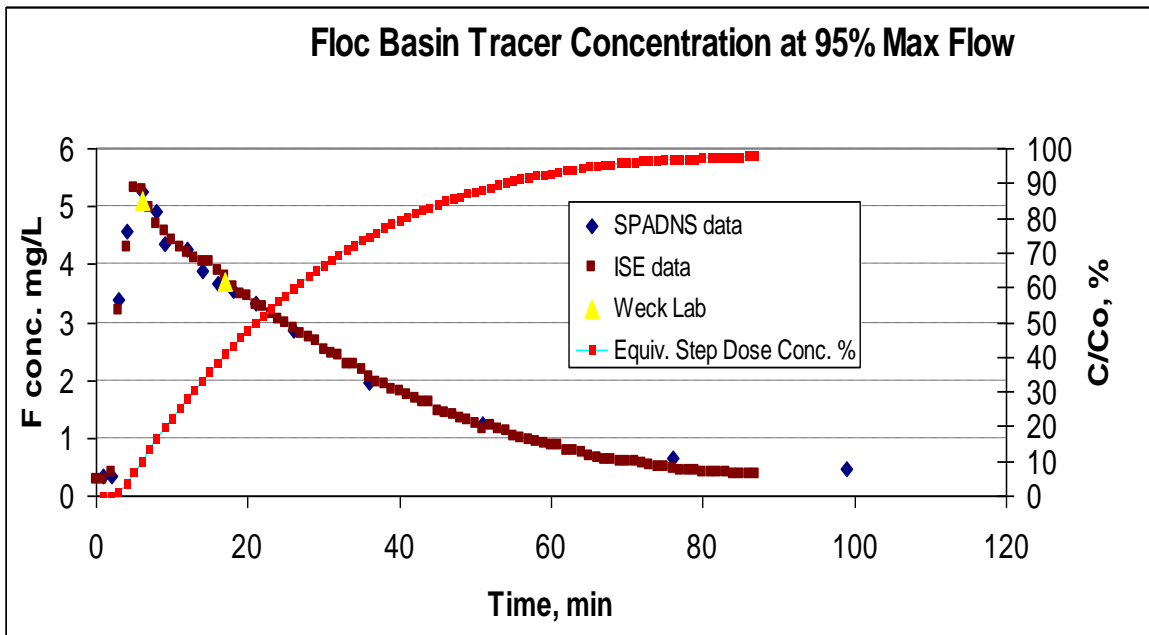

Figure 3-6: Tracer Study of Flocculent Basin at 50% Max Flow

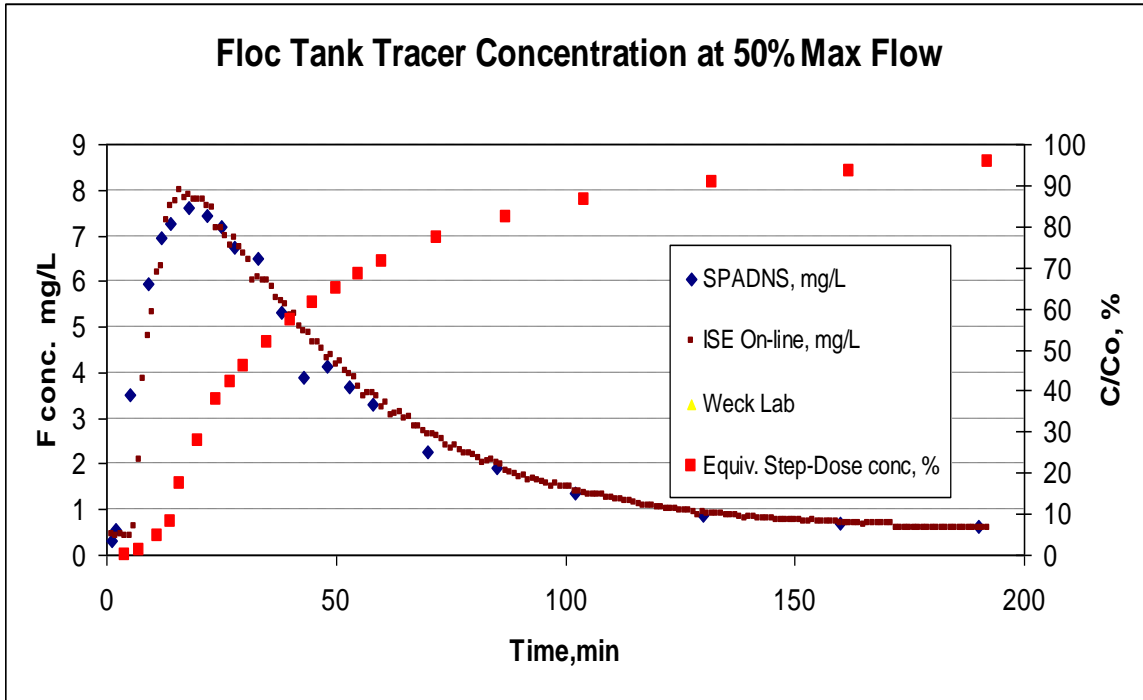

Table 3-1.  
Tracer Study for the Temple WTP

Treatment Process	Basin Volume	H <sub>2</sub> SiF <sub>6</sub> Added	Flow	HRT	T10	Baffling Factor	Tracer Recovery
	(gal)	(gal)	(gpm)	(min)	(min)		%
Filters 95% Flow	66,000	3	4350	15.2	12	0.79	101
Filters 95% Flow, Duplicate	66,000	5	4350	15.2	12	0.79	92
Filters 50% Flow	66,000	6	2150	30.7	21	0.68	93
Sed Basins 95 % Flow	440,000	7.5	4150	106.0	48	0.45	98
Sed Basins 50% Flow	440,000	12	2150	204.7	69	0.34	93
Floc Basins 95% Flow	118,500	2.5	4150	28.6	6	0.21	98
Floc Basins 50% Flow	118,500	5	2200	53.9	13	0.24	96

### 3.3. Discussion

#### Accuracy and Precision of Results

Excellent agreement was obtained between the Hach fluoride measurements performed in the field and the samples submitted for laboratory analysis. Continuous monitoring with the ISE electrode allowed for the capture of the leading edge of the tracer plume to within +/- 1 minute in all cases. Sufficient fluoride was added, and the monitoring period was

sufficiently long enough to produce recoveries greater than 90% in all cases. An instance where the reported recovery is greater than 100% is due to the analytical variation noted above.

A replicate tracer test of filter basin at 95% flow was performed; this test resulted in an identical baffling factor (0.79) with the initial tracer test.

**Variation of the Baffling Factor Estimates**

Conservative estimates of baffling factors were obtained from these tracer tests by taking the lowest baffling factor observed for each unit process (between the two flow rates) and rounding down to the nearest tenth.

**Table 3-2.  
Baffling Factors for the Temple WTP**

Unit Process	Baffling Factor
Filter Basin	0.7
Sedimentation Basin	0.3
Flocculent Basin	0.2

In several process units, there was a degradation of the baffling factor at 50% of the maximum flow rate. The T10 values became increasingly shorter relative to the theoretical detention time. The effects were observed when there was less dispersion such as in the sedimentation basin and, to a lesser extent, in the filter basin. This may be attributed to less unified flow profiles at lower flow rates, leading to a higher tendency for short circuiting and depressing the ratio of T10 over the theoretical detention time.

There is also a possibility of the filter basin baffling factor changing noticeably depending on the actual water held inside the filter. The total filter volume was estimated to be 66,000 gal, of which 22,000 gal was contained in two long and narrow clear water channels flanking both sides of a filter (Figure 3-8). The remaining water was mostly located within the filter. The depth of the water stream in the narrow clear channels (3'W x 110'L) was observed at 4.5 ft, but it can vary between 4-5 ft. The water level inside the filter can also vary from 3.5 ft to more than 4 ft. The levels change constantly during operation depending on the instantaneous variations between supply and demand. An error in the volume estimate can affect the calculated baffling factor as much as 20%-25%. Surveying the water levels in the filter section is important to accurately estimate the volume being held.

**Figure 3-7: Filter Basin Layout**

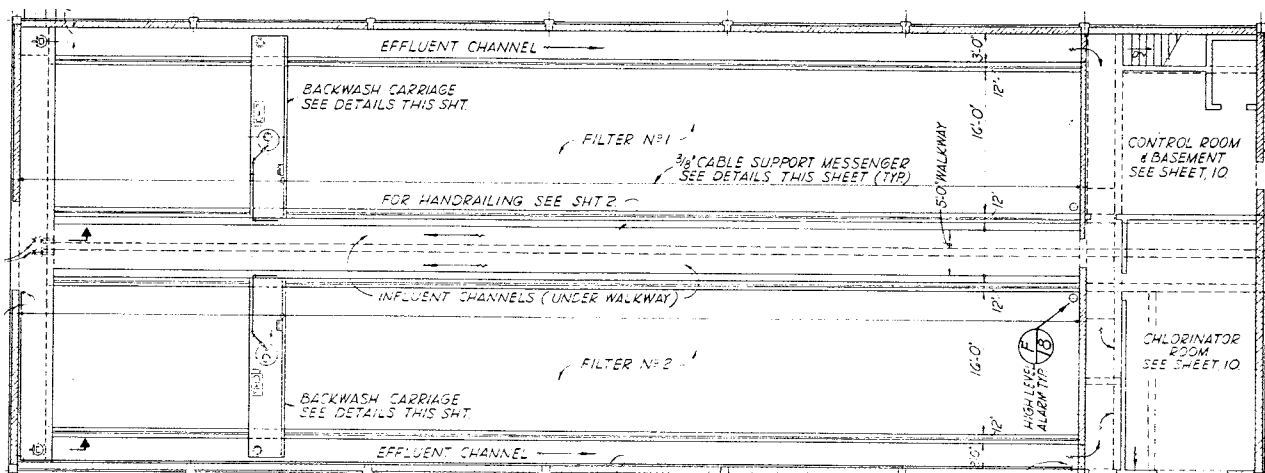

At 95% max flow, the total plant baffling factor was calculated to be 0.45 by dividing the total T10 over the sum of theoretical detention times. The factor reduced to 0.36 at the 50% flow condition.

### **3.4. Conclusions**

Accurate and reproducible tracer tests using fluoride were performed for the Temple WTP. The results will be used to calculate the CT under the current practice of using free chlorine disinfection for both primary and residual disinfection. The baffling factors are important if the Filter is used for a possible chlorine/chloramines DBP compliance strategy. The calculation of CT based on the calculated baffling factors will be included in Section 4, which is dedicated to the disinfection profiling of the Temple WTP.

## 4. Disinfection Profiling and Benchmarking

---

In this chapter, the results of the tracer study (described in Chapter 3) are applied to predict the Disinfection capability of the plant after the proposed UV and chloramine disinfection retrofit is completed.

### 4.1. Methods to Construct the Disinfection Profile and Benchmarking

The proposed retrofit of the Temple WTP with UV disinfection and chloramine residual requires the following modifications:

- Move the chlorine injection point
- Change the type of disinfectant
- Change the disinfection process

According to the EPA guidelines EPA 815-R-99-013 <sup>1</sup>, The Temple WTP is required to develop existing disinfection profile & benchmarking for *Giardia Lamblia Cysts* and viruses. The log inactivation requirements for viruses with free chlorine are much smaller than the *Giardia* requirements; therefore, meeting the requirements of *Giardia* log inactivation also qualifies the Temple WTP for the virus inactivation requirements.

The log inactivation requirements for viruses will be provided with free chlorine after the retrofit with UV, based on the tracer study results for the filter. The projected *Giardia* inactivation after the retrofit will be provided separately by the UV disinfection system.

### 4.2. Disinfection Profile

The Surface Water Treatment Rule<sup>2</sup> (SWTR) requires physical removal and/or inactivation of 3-log (99.9 percent) of *Giardia* and 4-log (99.99 percent) of viruses. For the Temple WTP at elevated turbidities the CDPH requires an additional log *Giardia* and Virus removal for a total of 4-log *Giardia* and 5-log virus removal. The filters are given 2-log *Giardia* credit so an additional 2-log *Giardia* is required under high turbidity conditions.

For disinfection profiling and benchmarking, the contact time (CT) approach will be used to compute the log inactivation achieved during water treatment. The CT required for 2-log inactivation of *Giardia* is roughly an order of magnitude higher than the CT required for 4-log or 5-log inactivation of viruses. Fulfilling the requirement for *Giardia* inactivation would be sufficient for virus inactivation. No data on virus inactivation is included in this disinfection profile and benchmarking.

The SWTR CT Tables were used along with data on residual chlorine, temperature, pH, and peak hour flow rate to calculate the ratio of the actual plant CT to the CT corresponding to the required 2-log *Giardia* inactivation. As described above, the Temple WTP has two symmetrical units for each conventional process, and each unit process has identical hydraulic properties. Sodium Hypochlorite is injected at the influent of the flocculent basin and the residual is monitored at the filter effluent. A second injection point is located at the plant effluent to raise the chlorine residual further if needed. The log inactivation was calculated based on the residual chlorine level exiting the filters.

The total log inactivation for *Giardia* is the sum of log inactivation for the plant and the transmission line to the first retail agency. The conventional plant has a volume of 1,249,000 gallons. The transmission line volume is 62,000 gallons. The baffling factors for these segments are 0.46 and 1.00, respectively. The Temple WTP receives 2-log *Giardia* removal from the continuous backwash filters, which is reduced to 1-log credit based on raw water turbidity values (typically when water is diverted directly from the San Gabriel River).

From the daily estimated plant log inactivation data spanning four years (2004 through 2007), a disinfection profile for three complete years was created (November 2004 through October 2007 - see Figures 4-1 through 4-3). The required *Giardia* log inactivation varied from 1 to 2, as illustrated in the figures, depending on the influent turbidity into the plant. When turbidity values are lower, an additional 1-log inactivation of *Giardia* is required. The required log activation is raised to 2-log when the turbidity of the source water is elevated.

Figure 4-1: Profiling Data from November 2004 to October 2005

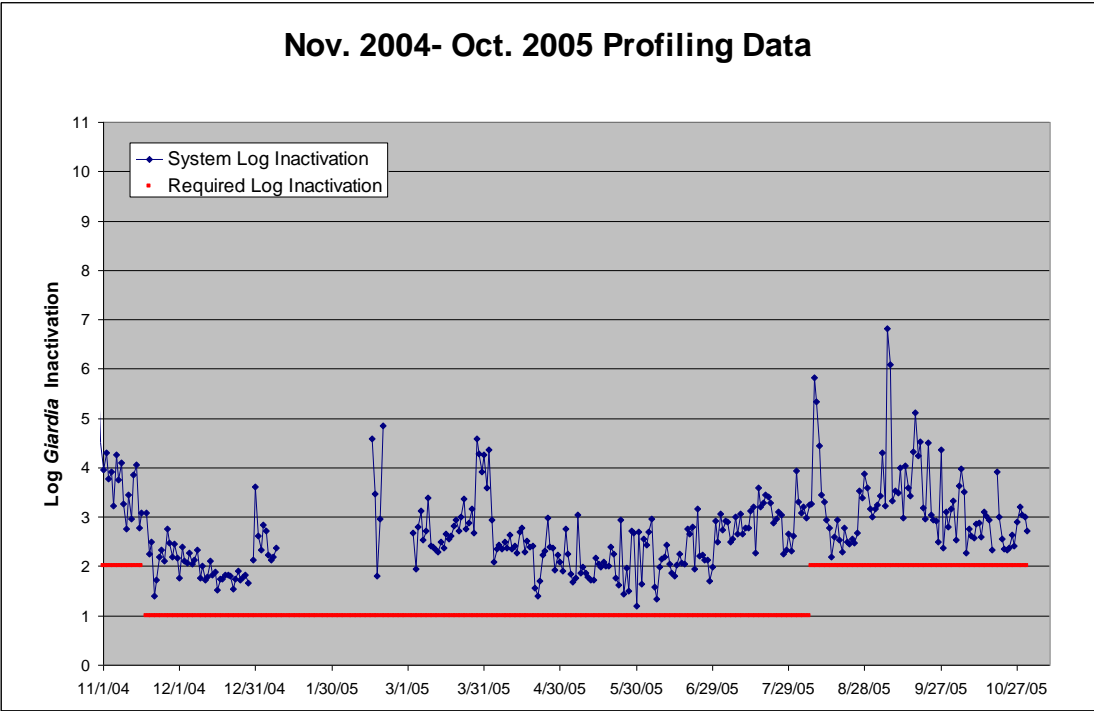

NOTE: The Temple WTP shut down for more than a month in early 2005 because of high turbidity of raw influent water

Figure 4-2: Profiling Data from November 2005 to October 2006

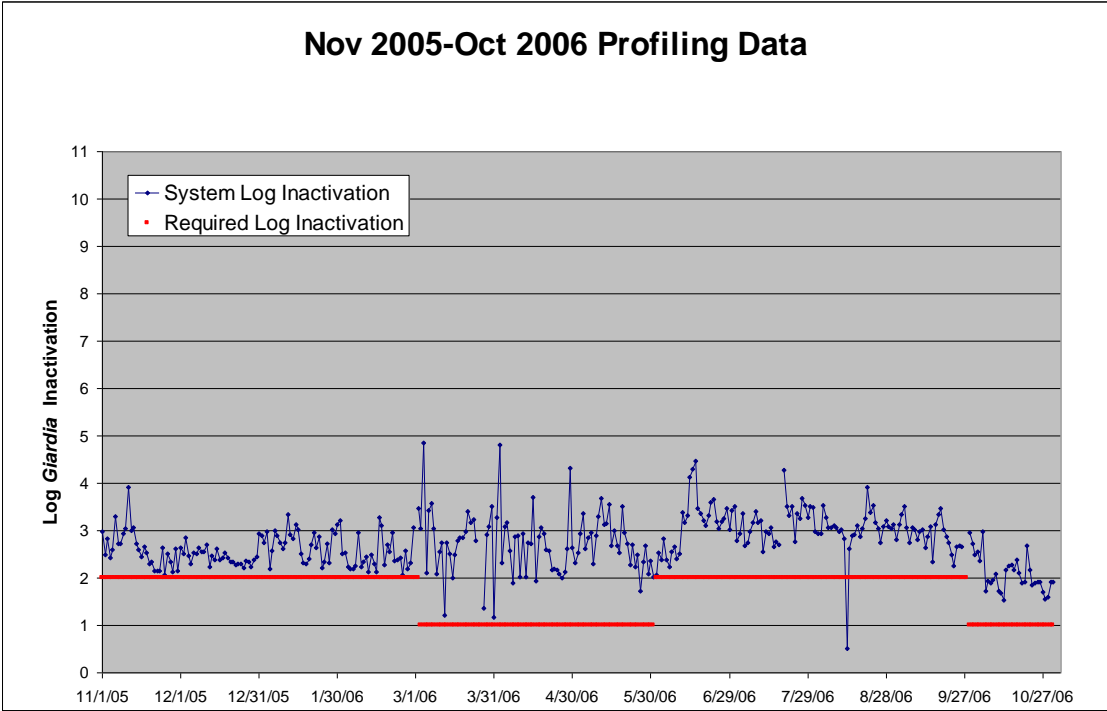
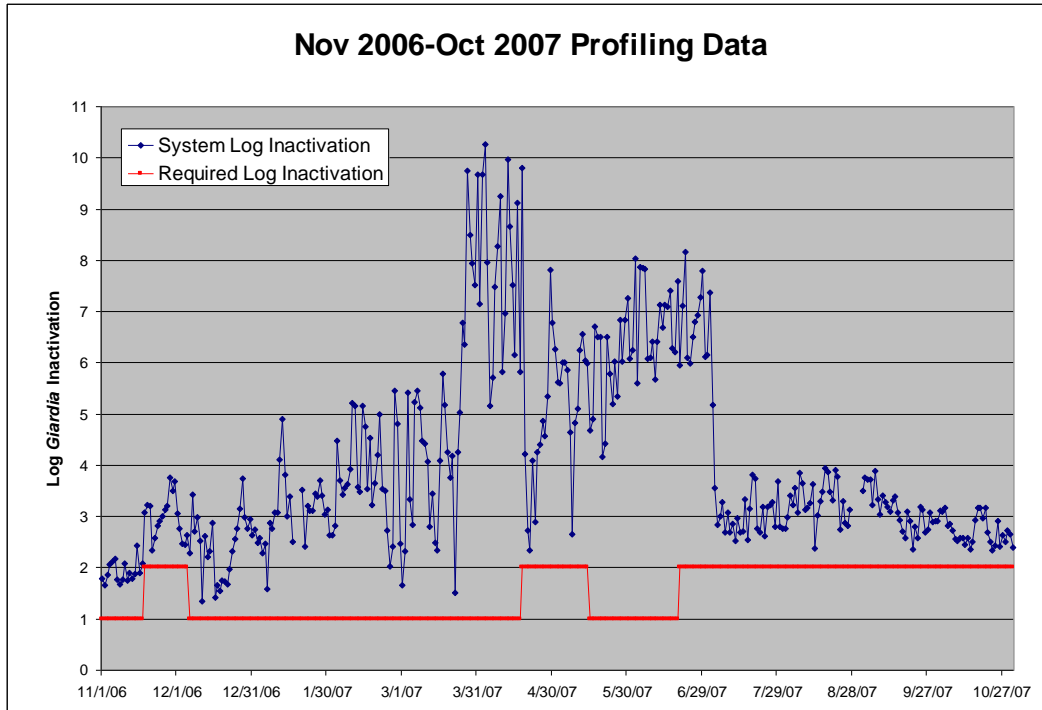

Figure 4-3: Profiling Data from November 2006 to October 2007



### 4.3. Disinfection Benchmark

From the daily plant log inactivation records, the average log inactivation for each calendar month was computed. The lowest monthly average log inactivation values for each 12-month period were then averaged to determine the benchmark. Results of the benchmark calculations are included in the Table 4-1.

Table 4-1.  
Critical Periods for Existing Disinfection Practice

Year	Month of Critical Period for <i>Giardia</i> Inactivation	Log Inactivation of <i>Giardia</i>
Nov 2004- Oct 2005	December	1.96
Nov 2005- Oct 2006	October	2.04
Nov 2006- Oct 2007	November	2.44
<b>Average</b>		<b>2.15</b>



Figure 4-4: Log *Giardia* Benchmark for three years ending October 2007

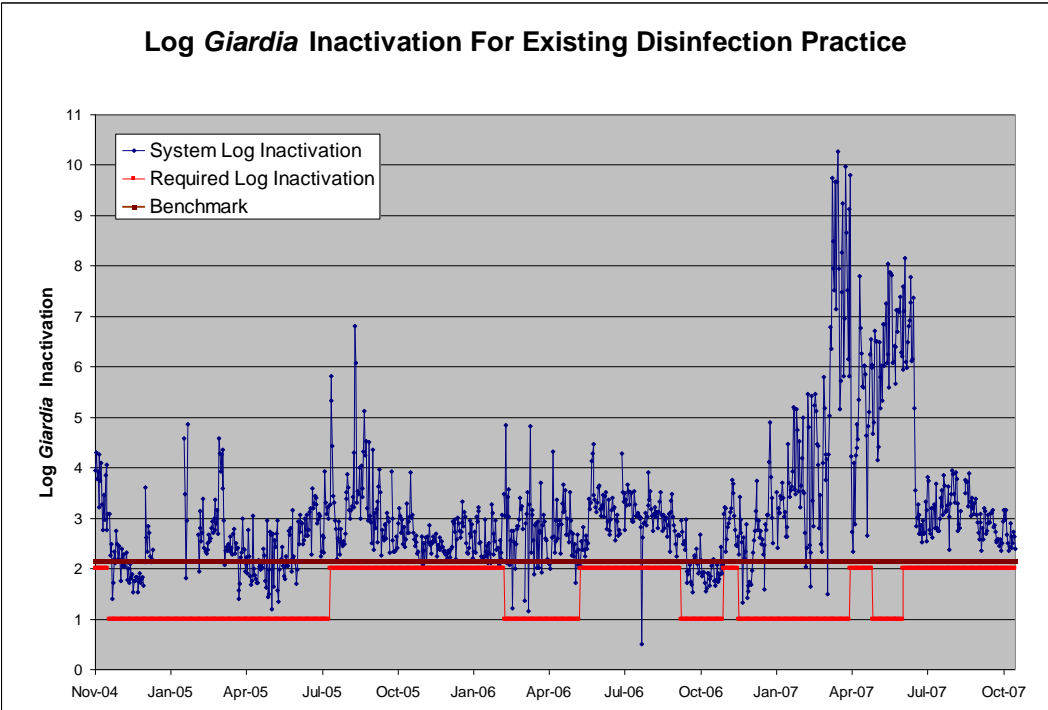

#### 4.4. Temple WTP Turbidity and Coliform Data

Data on turbidity and coliform counts of influent water to the Temple WTP collected from 2005 to 2007 are presented in Figure 4-5. The plant was shut-down temporarily from January 10, 2005 to February 28, 2005 due to an increase in turbidity in the raw water to above 100.

Figure 4-5: Influent Turbidity and Coliform Counts

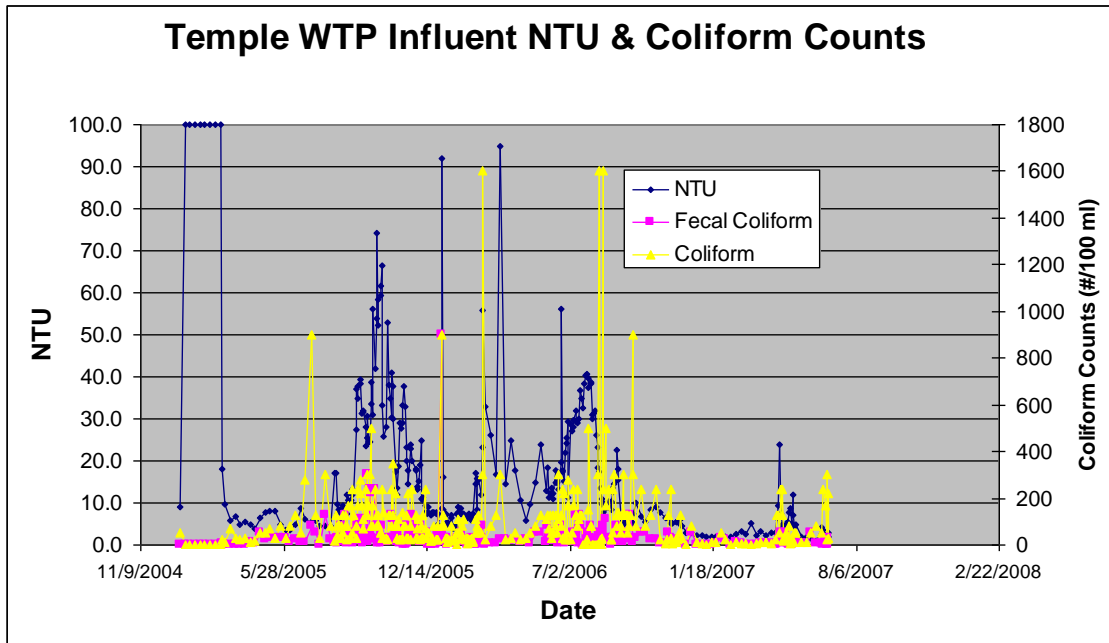

There was a general correlation between the high turbidity values and high coliform counts but there were inconsistencies due to time shifts between peak values. The coliform counts were within the treatment capability of the filters based on the Guidelines<sup>3</sup>. The current supply of raw water to the Temple WTP is not expected to generate issues related to the treatment capacity of the plant in the foreseeable future.

#### 4.5. Predicted Inactivation Levels after UV/Chloramine Retrofit

With the proposed UV/Chloramine retrofit, *Giardia* disinfection will be provided primarily by the UV treatment. A level of chloramine residual is maintained by injecting hypochlorite into the influent and ammonia at the effluent of the filter. Due to the location of the injection point of hypochlorite and ammonia, the total filter CT with free chlorine can be applied to the virus and *Giardia* log inactivation.

The results of the tracer study indicate that the baffling factor of the filter basin is 0.7. Assuming conservative treatment conditions (when flow and pH are maximized at the lowest temperature), the CT value for 4-log inactivation of virus was estimated from the Guidelines<sup>2</sup> to be 6 mg-min/L, maximum.

**Table 4-2.**  
**Projected Log Inactivation of Virus and *Giardia* in the Temple WTP Filter Section**

Basin Volume (gal)	Flow (gpm)	Theoretical Residence Time (TRT) (min)	Baffling Factor	Effective Retention Time (min)	CT <sub>calc</sub> (mg-min/L)	CT <sub>calc</sub> /CT <sub>required</sub>	Log Inactivation
<b><u>Virus Inactivation</u></b>							
66,000	4340	15.2	0.7	10.6	27	4.5	18
<b><u>Giardia Inactivation</u></b>							
66,000	4340	15.2	0.7	10.6	27	0.84	0.4

Based on Chlorine residual: 2.5 mg/L CT for 4 log-inactivation of viruses: 6 mg/min-L. CT for 1/2 log *Giardia*: 32 mg/min-L  
Temperature: 10°C pH: 8 Flow: 12.5 MGD

The total virus inactivation was estimated to be 18, which exceeds the required 3 or 4 log virus inactivation. The *Giardia* inactivation will be less than 0.5-log and fails to meet either the 1-log requirement with low turbidity source water or the 2-log requirements with elevated source water turbidity. However, with the addition of UV disinfection, 3-log *Giardia* and *Cryptosporidium* inactivation will be provided, exceeding the current plant disinfection capability and providing a multi-barrier disinfection process.

#### 4.6. Discussion

With the proposed retrofit, the *Giardia* log-inactivation will be mostly provided by UV disinfection. As discussed above the relocation of the chlorine addition point and use of chloramines will reduce the *Giardia* inactivation to less than 0.5-log with free chlorine. In order to provide a level of safety for *Giardia*, the full *Giardia* inactivation will be met using UV disinfection. The chlorine residual after the retrofit will be designed for 2.5 mg/L to ensure the Temple WTP consistently meets the CT requirements. With the high value of anticipated virus log inactivation of 18, the residual chlorine values can be as low as 0.6 mg/L without the risk of not achieving the required log inactivation. This difference provides the plant the ability to optimize dosages to reduce DBP formation and also provide a beneficial factor of safety.

#### 4.7. Conclusions

The Temple WTP has met the requirements for *Giardia* log inactivation, and the influent water turbidity and coliform counts were considered to be acceptable.

The proposed UV/Chloramine retrofit would improve the disinfection capability of the Temple WTP and will allow the Temple WTP to meet current and foreseeable regulatory requirements for disinfection. By changing the injection point of hypochlorite from the

plant influent to the influent of the filters, DBP's are expected to decrease, and the WTP disinfection requirements for *Giardia* and virus can be met with an additional level of safety.

#### **4.8. References**

1. Disinfection Profiling and Benchmarking Guidance Manual, US EPA Document 815-R-99-013, August 1999.
2. Guidance Manual for Compliance with the Filtration and Disinfection Requirements for Public Water Systems using Surface Water Sources, Publication based on Contract No 68-01-6989, Malcolm Pirnie Inc and HDR Engineering, Inc, October 1990.
3. Guidelines for Determining When Surface Waters Will Require More Than The Minimum Levels of Treatment Defined in The Surface Water Treatment Regulations, Table 4-2.

# 5. Basis of Facility Design

## 5.1. Treatment Process Hydraulics

The WTP currently controls the flow into the plant through the inlet flow control valve. The plant feeds by gravity through the flocculation/sedimentation basins to the filters, then to the high service pumps. The flow out of the plant is controlled by the operation of the high service pumps. Currently there are 5 high service pumps; three pumps feed a lower pressure zone and two pumps feed a higher pressure zone. The existing pumps are mounted vertical turbine pumps, and the design parameters for the existing pumps are shown in Table 5-1.

**Table 5-1. Design capacity of high service pumps.**

<b>Pump</b>	<b>HP</b>	<b>Design Flow</b>	<b>Design TDH</b>	<b>Shutoff Head</b>
Low Pressure Zone Pump 1 (D-1)	40	2,000	45	70
Low Pressure Zone Pump 2 (D-2)	40	2,000	45	70
Low Pressure Zone Pump 3 (D-3)	100	8,000	37	85
High Pressure Zone Pump 1 (T-1)	40	480	280	455
High Pressure Zone Pump 2 (T-2)	60	720	280	455

The UV reactors will be installed post-filtration in order to treat the water with the highest UV transmittance (UVT), which will minimize energy usage. The water surface elevation downstream of the filters is only a few feet above the existing grade and the UV reactors must be installed in a configuration in which they will not be exposed to low or negative pressures. Therefore, the UV reactors can either be installed below grade between the filters and the high service pumps, or be installed above grade with a booster pump station installed between the filters and high service pumps. The above grade system would require continuous pumping of the full plant flow under all hydraulic conditions and would result in a configuration that would be subject to potential surge

problems. Surge events could result in negative pressures at the reactors. The installation of the reactors below grade represents the best option for the CICO WTP. This configuration will minimize the hydraulic impacts to the site by only adding the small additional headloss associated with the reactors (1-2') and eliminating inter-stage pumping. In addition, since the high service pumps are near the end of their expected operating life, the high service pumps station can be replaced and modified to accommodate this configuration. The high service pumps will be installed in a wetwell downstream of the UV reactors, which will help minimize any potential surge problems for the UV reactors. Since the addition of the UV reactors between the filters and pumps will not have a significant impact on the design conditions for the high service pumps, the new high service pumps will be based on the existing pumps design conditions shown in Table 5-1. Figure 5-1 shows the proposed hydraulic configuration of the WTP after the addition of the UV facilities and the wetwell. Figure 5-1 illustrates that under certain hydraulic conditions, it is possible to gravity feed the low pressure zone; therefore a gravity feed line from the wetwell to the low pressure zone will be provided.

**Figure 5-1: Proposed Hydraulics with UV/Chloramine**

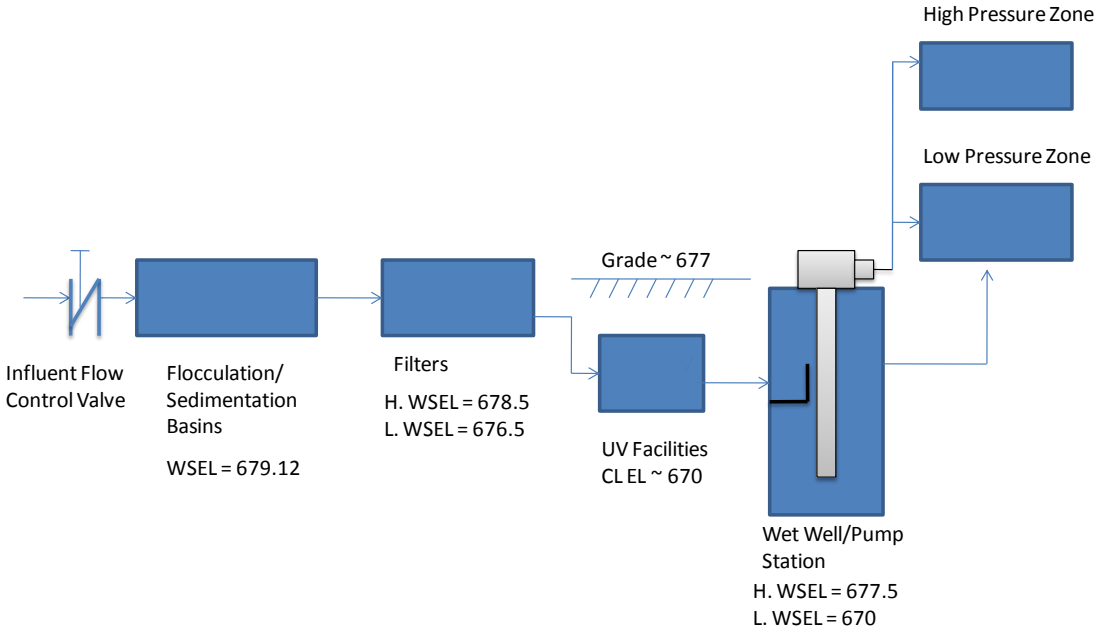

**5.2. Basic Design Assumptions**

The following assumptions for capacity and redundancy were made in developing the basis of design for the disinfection facilities:

- The disinfection facilities will be designed to treat the maximum day flow rate of 12.5 MGD based on the maximum daily flow observed between January 2005 and June 2007
- The proposed facilities will be designed to provide a level of safety over the required inactivation requirements. The proposed facilities will be designed for the minimum level of inactivation shown below in Table 5-2.
- The UV facility will be designed to achieve 3-log *Giardia* and *Cryptosporidium* inactivation and will be operated for 3-log *Giardia*.
- The free chlorine contact time will be sized to achieve a minimum of 4-log virus inactivation, but will likely operate under a higher level of virus inactivation.
- Aqueous ammonia will be added to form chloramines after the required CT for virus inactivation is achieved. Chloramines will be used as the secondary disinfectant.

**Table 5-2. Minimum Level of Activation for Proposed UV Facility**

Process	<i>Giardia</i> Inactivation	Virus Inactivation	<i>Cryptosporidium</i> Inactivation
Filtration <sup>1</sup>	2-log	1	2-log
Free Chlorine	0	4-log	0
UV Disinfection	3-log	0	2-log
Total	5-log	5-log	4-log

1. The Automatic Backwashing filters are not given full filtration credit by the CDPH.

## 6. Chemical Facilities

---

The chemical facilities include chlorine and ammonia to form chloramines. This section describes the chlorine and ammonia design criteria and assumptions.

### 6.1. Chemical Facility Overview

Modifications will be made to the existing sodium hypochlorite (NaOCl) storage and feed facility, and a new aqueous ammonia (NH<sub>4</sub>OH) storage and feed facility will be constructed. As shown in Figures 5-2 and 6-1, two new tanks, one for sodium hypochlorite and one for ammonium hydroxide, will be located in a new chemical storage area west of the filter building. The area west of the filter building is on CICO property but is currently leased to another company. The sodium hypochlorite storage area will have two transfer pumps (one duty, one standby) for transferring NaOCl from the new hypochlorite storage tank to the existing storage tank. The existing hypochlorite metering pumps will be replaced with four peristaltic metering pumps. One pair of metering pumps (duty/standby) will be dedicated to the raw water and post filtration feed points. The other pair will be dedicated to the pre-filtration and post-flocculation feed points. It is anticipated that under typical conditions chlorine will be fed pre-filtration and boosted post-filtration. The aqueous ammonia containment area will include two chemical metering pumps (one duty, one standby).

Sodium hypochlorite will be injected prior to UV disinfection to provide free chlorine disinfection. Aqueous ammonia will be injected downstream of the chlorine injection points. The ammonia will react with the chlorine residual and form chloramines. The design criteria for the sodium hypochlorite and aqueous ammonia facilities are summarized in Table 6-1. The hypochlorite and ammonia tanks are designed to provide a minimum of 21 days of storage for maximum flow and dose.



**Table 6-1.  
Chemical Facilities Design Criteria**

Parameter	NaOCl	NH <sub>4</sub> OH
Peak Design Flow	12.5 MGD	12.5 MGD
Maximum Dose	6 mg/L as Cl <sub>2</sub>	0.72 mg/L as NH <sub>3</sub> <sup>1</sup>
Average Dose	3.5 mg/L as Cl <sub>2</sub>	0.67 mg/L as NH <sub>3</sub> <sup>2</sup>
Maximum Usage at Design Flow (Maximum Dose)	625 ppd	75 ppd
Design Solution Strength (%)	12.5% as Cl <sub>2</sub>	19% as NH <sub>3</sub>
Maximum Usage at Design Flow (Maximum Dose)	530 gpd	51 gpd
Days of Storage at Design Flow (Maximum Dose)	21	21
Minimum Usable Storage Volume	11,130 gallons	1,071 gallons
Type of Storage Tank	Single Wall	Single Wall
Material	Fiberglass Reinforced Plastic (FRP)	Steel or Stainless Steel
Number of Metering Pumps	4 (2 duty, 2 standby)	2 (1 duty, 1 standby)
Type of Metering Pump	Peristaltic	Peristaltic
Metering Pump Capacity	22 gal/hr	2.1 gal/hr
Pipe and Valve Materials	PVC	PVC
Secondary Containment Area	Concrete	Concrete

1. Dose based on a residual of 2.5 mg/l and a Cl<sub>2</sub>:NH<sub>3</sub>-N ratio of 5.2:1
2. Dose based on a residual of 2.5 mg/l and a Cl<sub>2</sub>:NH<sub>3</sub>-N ratio of 4.5:1

## 6.2. Storage Tank Design

To minimize chemical delivery at the plant, 21-day storage of both ammonium hydroxide and sodium hypochlorite will be kept on site. For sodium hypochlorite, 11,130 gallons of storage is required, but the Temple WTP has an existing sodium hypochlorite storage tank on site with a working volume of 6,500 gallons, so additional storage of only 4,630 gallons is needed. The sodium hypochlorite storage tank will have a 5,000 gallon working volume and the aqueous ammonia tank will have a 1,500 gallon working volume to meet the 21-day storage requirement. Additional volume will be provided to allow a minimum chemical height above the pump elevation and between the tank high level and overflow pipe. Sodium hypochlorite will be pumped from the new storage tank to the existing tank via a new transfer pump, and the sodium hypochlorite injection will take place using the existing tank and pumps. The aqueous ammonia will be injected downstream of the UV facility using the new pumps. Table 6-2 summarizes the recommended chemical storage tank parameters.

**Table 6-2.  
Storage Tank Design Parameters**

Tank Identification	Active Capacity per Tank (gals)	Total Capacity per Tank (gals)	Tank Dia. (ft)	Straight Shell Height (ft)	Chemical
Existing NaOCL Tank	6,500				12.5% NaOCl Solution
New NaOCl Storage Tank	5,000	6,500	10	11	
New NH <sub>4</sub> OH Storage Tank	1,500	2,254	8	6	19% NH <sub>4</sub> OH Solution
New NH <sub>4</sub> OH Neutralization Tank	200	250	3	4	Water

The new sodium hypochlorite tank will be constructed of fiberglass and have the following tank connections and appurtenances:

- 2-inch diameter pump suction
- 3-inch tank drain
- 2-inch fill nozzle with internal draft tube
- 3-inch overflow
- 30-inch side manway
- 4-inch gooseneck vent
- Sight glass
- Ultrasonic level indicator
- FRP ladder with safety cage

The new ammonium hydroxide tank will be constructed of stainless steel or steel and will be designed as a pressure vessel for 35 psig, due to the high vapor pressure associated with 19% ammonia hydroxide. A relief valve will be routed to a neutralization tank if the internal design operating pressure is exceeded. The ammonia tank will have the following tank connections and appurtenances:

- 2-inch diameter pump suction
- 3-inch tank drain
- 2-inch liquid fill nozzle with internal draft tube
- 2-inch vapor return
- 2-inch pressure relief routed to the neutralization tank.
- 30-inch side manway
- Sight glass
- Ultrasonic level indicator
- FRP ladder with safety cage

### 6.3. Containment Area

The new chemical storage tanks will be located in a concrete containment area consisting of a concrete slab, 30-inch high containment walls, a sunshade roof, and surrounded by privacy fencing. Each tank will have a separate containment area, with the capacity to contain the entire volume of the tank plus an additional 10%. Sufficient clearance will be provided around the tanks and pump for access and maintenance.

Each tank will have a fill station for unloading chemicals from a tanker truck. A fully supported fill pipe with quick disconnect will be located inside the containment area walls to allow spills to be captured in a chemical trench connected to a sump to allow chemical removal. All chemical deliveries will be received at the new chemical area. Sodium hypochlorite will be supplied to the existing storage tank with two transfer pumps located within the new sodium hypochlorite containment area to transfer to the existing tank.

Four emergency shower and eyewash stations will be located at the new chemical storage facility. Each fill station will have an emergency shower and eyewash located adjacent to it. Additionally, one emergency shower and eyewash will be provided inside each tank containment area near the pump pads.

### 6.4. Metering Pumps

Metering pumps will be used to distribute chemicals to the application sites in the Temple WTP. Four (4) peristaltic metering pumps will be provided. Two (1 duty + 1 standby) will be used to feed either the rapid mix or post-filtration application points and two (1 duty + 1 standby) will be used to feed either the post flocculation or pre-sedimentation application points. It is anticipated that typical operation will be to dose chlorine pre-filtration and boost the chlorine post filtration.

**Table 6-3.  
Sodium Hypochlorite Requirements**

Temple WTP Flow	Dose (mg/L)	Metering Pump Flow (gph)
1 MGD	3	0.89
	6	1.8
12.5 MGD	3	11
	6	22

**Table 6-4.  
Aqueous Ammonia Requirements**

Temple WTP Flow	Dose (mg/L)	Metering Pump Flow (gph)
1 MGD	0.7	0.2
12.5 MGD	0.7	2.1

The ammonia metering pumps will be located in the chemical containment area. The ammonia hydroxide discharge point will be immediately downstream of the filters. Both metering pumps will be fed directly to the application point. In order to prevent scaling in the feed lines, no carrier water will be used.

## 6.5. Sodium Hypochlorite Transfer Pumps

To take advantage of existing facilities, the existing sodium hypochlorite tank will be used and a new tank installed to provide additional storage capacity. The existing tank is located at the east end of the plant and the new tank will be housed in a new containment area located on the west side of the plant. A transfer pump will be used to convey sodium hypochlorite from the new tank to the existing one. The transfer pump will have the following characteristics:

Number of Units:	2 (1 duty + 1 standby)
Type:	Seal-less magnetic drive centrifugal
Materials of construction:	Polypropylene Body, Viton Seals w/ Teflon bushings
Capacity:	25 gpm
Drive type:	Constant speed

With the transfer pump, the contents of the new sodium hypochlorite storage tank could be transferred to the existing tank in approximately 4 hours. A single transfer pump will be provided. In the event that the transfer pumps fail and cannot be repaired or replaced before sodium hypochlorite is required or if the new tank needs to be taken of line for service, the chemical unloading facilities at the existing storage tank will be maintained and used as necessary.

## 6.6. Additional Application Points

To provide CICO with maximum flexibility for the point of sodium hypochlorite dosing, two additional application points will be provided: the front of each sedimentation basin and following sedimentation. There are existing application points at rapid mix and following filtration. Based on influent water quality, sodium hypochlorite can be fed in four locations in the water treatment process: at rapid mix, after flocculation, prior to filtration or after filtration. New chemical distribution piping will be installed from the sodium hypochlorite metering pumps piping to the two new application points. The piping material will be CPVC.

## 7. UV Disinfection Facility

---

The UV facilities will provide 3-log *Giardia* and *Cryptosporidium* inactivation. This section describes the UV facility design criteria and assumptions.

### 7.1. Integrating UV Disinfection into the Treatment Process

The UV dose tables in the Long Term 2 Enhanced Surface Water Treatment Rule (LT2ESWTR) and the design and operational recommendations in the USEPA UV Disinfection Guidance Manual (UVDGM) apply to UV disinfection facilities after filtration or systems that meet filtration avoidance criteria. The UV disinfection facility at the Temple WTP will be downstream of the filters on the combined filter effluent piping and downstream of the chloramine addition point. High-service pumps will be located directly downstream of the facility.

UV reactors are typically constructed to withstand operating pressures greater than 150 psi. However, negative pressures less than -1.5 psi may cause lamps to break. Since this UV facility is located directly before the high service pumps, the pumps will be installed in a wet well to provide surge protection.

### 7.2. Key Design Parameters

The key design parameters for the UV facility are summarized in Table 7-1 and are described in more detail in the following sections.

**Table 7-1.  
Key Design Parameters for the UV Disinfection Facility**

Design Parameter	Value
Target Pathogen	3-log inactivation of <i>Cryptosporidium</i> <sup>1</sup>
Required UV Dose	12 millijoules/square centimeter (mJ/cm <sup>2</sup> ) (does not include validation factor)
Flow Rate	13.0 mgd
UVT	80%
Fouling/Aging Factor	0.8
Off-Specification Requirement	<5% of water off-specification (minimize to the extent possible)
Power Quality	Uninterruptable power supply (UPS) system required
Lamp Type	Medium pressure UV lamps
Validation Considerations	Off-site validation with male-specific-2 (MS2)

<sup>1</sup> Operation will be based on 3-log *Giardia* inactivation.

### 7.2.1. Target Pathogen and UV Dose

The required UV dose specified in the LT2ESWTR to achieve 3-log inactivation of *Giardia* is 11 millijoules/square centimeter (mJ/cm<sup>2</sup>). Although *Giardia* is the target pathogen, the UV facility will be designed to achieve 3-log inactivation of *Cryptosporidium*, which has a required dose of 12 mJ/cm<sup>2</sup>. Designing for *Cryptosporidium* inactivation is more conservative and will allow flexibility in the future if a change in source water quality requires additional *Cryptosporidium* inactivation. To receive inactivation credit, the UV reactors must deliver a validated dose that is greater than or equal to the required dose. Validated dose is the UV dose in mJ/cm<sup>2</sup> delivered by the UV reactor as determined through validation testing and documented in the validation report.

$$\text{Validated Dose} = \frac{\text{RED}_{\text{Calc}}}{\text{VF}} \quad \text{Equation 1}$$

where:  $\text{RED}_{\text{Calc}}$  = Calculated RED based on validation testing  
VF = Validation Factor determined in validation testing

### 7.2.2. Flow Rate

The design flow rate for the UV facility is 12.5 mgd and is based on the maximum daily flow observed between January 2005 and June 2007. The median daily flow over the same period was 8.4 mgd. The instantaneous flow was higher than 12.5 mgd in less than one percent of the values recorded on ten minute intervals in the SCADA system. To ensure that the flow through the facility does not exceed the validated limits, the flow reading will be programmed to decrease the plant influent and effluent flows if the design flow exceeds 12.5 mgd.

### 7.2.3. UV Transmittance

UVT is a measure of the amount of UV light at a specific wavelength (typically 254 nm) that passes through a water sample and is available for disinfection. The higher the UVT of a water, the more cost-effective UV disinfection will be. Historical filtered water UVT data is not available for the Temple WTP. Three UVT samples were collected in February and March of 2008. Raw water UVT ranged from 89.1 to 89.9 percent and filtered water UVT ranged from 94.4 to 95.3 percent. However, this is only two data points, and State Project Water typically has lower raw water UVT around 82%. Therefore, a conservative estimate of 80 percent UVT will be used in this design. Once the facility is operating and more UVT data are available, it is likely that the facility will operate at a much higher UVT, thereby reducing operational costs.

### 7.2.4. Fouling/Aging Factor

Lamp sleeve fouling and lamp aging are important factors to consider in design because both affect how much UV light is transmitted to the target pathogens. The fouling factor is a measure of the degree of fouling that may be present at a facility due to water quality and is site-specific. The aging factor is a measure of the difference in light output between new lamps and aged lamps.

Because the fouling factor is site-specific, reactor manufacturers typically use a combined fouling/aging factor to account for them. Based on conversations with the UV manufacturers, a factor of 0.8 that accounts for both lamp aging and lamp fouling is being used for the Temple WTP. However, the reactors under consideration have automated cleaning systems that are typically sufficient to mitigate fouling.

### 7.2.5. Off-Specification Requirements and Power Quality

The LT2ESWTR requires at least 95 percent of UV-treated water delivered to the public each month to be treated by UV reactors operating within validated limits. Operating outside of validated limits is defined as “off-specification”, which is accordingly limited to 5 percent by the LT2ESWTR. The 5 percent limit is calculated on a monthly basis and is determined based on the volume of off-specification water created. The reasons a UV reactor may be operating off-specification are as follows:

- A reactor operating outside its validated limits for flow, UVT, or UV intensity
- The intensity sensors or UVT analyzer (if required) are not in calibration
- The equipment in the reactor is of lesser quality than the equipment that was validated
- The validated dose is less than the required dose
- The one or more lamps are not energized while water flows through the reactor (unless validated with lamps off)

Although up to 5 percent of water may be off specification, it is recommended to minimize such operation to better protect public health. As such, the design criteria for

the UV facility at Temple WTP will be conservative to reduce the risk of operating off specification.

To reduce the potential for the reactor to operate outside its validated limits, conservative design values for flow and UVT were selected. A detailed maintenance and calibration program will also be followed to ensure the proper equipment is installed and to reduce the potential for equipment to be out of calibration.

Power quality issues can cause UV lamps to lose power. Because lamps can take up to 10 minutes to regain full power, even a brief interruption can result in under-disinfected water to be released for several minutes. At the Temple WTP, there is no downstream contact time available for emergency *Giardia* disinfection, so maintaining lamp power is particularly important. To mitigate the potential of lamp outages due to power quality issues, the UV facility at the Temple WTP will be designed with an uninterruptible power supply (UPS). In addition to the UPS, a back-up generator will also be supplied to power the facility in the event of prolonged power outages.

Because of the high operating temperature of medium pressure (MP) UV lamps, a minimal amount of cooling water is needed during startup. As it may take several minutes for the lamps to reach full power, the cooling water is considered off specification. To avoid releasing this water to the distribution system, The cooling water will be returned to the UV reactor influent by a pump.

### 7.2.6. Lamp Type

Two main types of UV lamps are typically used in drinking water applications (i.e., medium pressure (MP) and low-pressure high-output (LPHO)). Both lamp types have distinct advantages and disadvantages as summarized in Table 7-2.

**Table 7-2.  
UV Lamp Comparative Advantages**

Low-pressure high-output	Medium-pressure
<ul style="list-style-type: none"> <li>• Higher germicidal efficiency; nearly all output at 254 nm</li> <li>• Smaller power draw per lamp</li> <li>• Longer lamp life</li> </ul>	<ul style="list-style-type: none"> <li>• Higher power output</li> <li>• Fewer lamps for a given application</li> <li>• Lower facility footprint</li> <li>• Less operations and maintenance because of fewer lamps and UV sensors</li> </ul>

The optimal lamp technology for a given application depends on many factors, including footprint, energy consumption, reactor controls, and facility maintenance. During the conceptual design (completed in October 2006), several UV reactor designs available



from various manufacturers were evaluated. Although the UV reactors using low pressure lamps were more energy efficient, the smaller footprint of the reactors using medium pressure lamps made them more desirable. In addition, the maintenance tasks for MP reactors typically require less labor because there are fewer lamps to replace.

### 7.2.7. Validation Considerations

The LT2ESWTR requires that UV reactors be validated to receive inactivation credit. It was assumed for the design of this facility that only pre-validated UV reactors would be purchased. The selected reactor must have been validated according to the November 2006 UVDGM requirements and recommendations. The reactor must also have been validated under all of the conditions specified in Table 7-1. The UV facility piping configuration assumes that the UV reactors were validated with a 90 degree elbow immediately before the inlet to the UV reactor. According to the UVDGM, under this assumption, five pipe diameters of straight pipe will be necessary upstream of where the UV reactors are installed. The downstream piping configuration is not specified in the UVDGM; however, discussions with UV manufacturers recommended two pipe diameters downstream. The UV disinfection equipment specification will provide detailed validation requirements.

## 7.3. Facility Layout

The preliminary layout of the UV facility is shown in Figure 7-1. To develop the facility layout, information from two UV manufacturers was collected, and the preliminary layout was based on the larger of the two systems to provide a more conservative estimate for the building footprint. Each manufacturer recommended a design to achieve design criteria described previously. The following considerations were used with developing the facility layout:

- Number of reactors – The 12.5 mgd facility is being designed with two reactors (one duty and one standby). The hydraulic capacity may provide for additional flow through the reactors at higher UVT or when lower inactivation is required.
- Piping – As recommended by the UVDGM, five pipe diameters of straight pipe are provided prior to the reactor. Two pipe diameters of straight pipe are provided after the reactor.
- Reactor spacing – The spacing between reactors provides adequate space for maintenance tasks for the reactors, piping, valves and meters.
- Control panel location – The distance must be less than the allowable separation distance required by the manufacturers. The control panel will be installed in the electrical room on the ground floor. This room is climate controlled to protect the PLC in the panel and also protect the panels from flooding. A remote HMI screen will be provided at the reactors on the lower level to assist with routine maintenance.

- Electrical equipment – The UPS and other electrical equipment are located at grade in the climate control electrical building. The generator will be located outside of the UV facility building in a self-contained enclosure.
- Valves – Valves are provided for isolation (to facilitate reactor maintenance) and air/vacuum relief.
- Storage – A storage area for spare parts is provided.

## 8. Other Improvements

---

### 8.1. Grit Chamber

To protect the pump in the existing clarifier for backwash water and to make maintenance less troublesome, a grit chamber will be installed after the filters and prior to the clarifier. A horizontal-flow grit chamber will need to be approximately 4 feet wide, 4 feet long, and 2 feet deep to allow enough settling time for sand particles. Sizing of the grit chamber was based upon a backwash flow of 500 gpm and a settling velocity of 4.5 ft/min.

### 8.2. Recycle Piping and Pumping

Currently, water used for backwashing the filters at the Temple WTP is released into an adjacent channel. To mitigate this water loss, piping will be installed to bring backwash wastewater to the front of the plant so it can undergo treatment. Based on a 500 gpm discharge rate of backwash water, a 40 foot length between the east and west end of the plant, and a 10 foot change in elevation between the two ends of the plant, a 4 inch pipe is needed.

In order for the water to be recycled from the west end of the plant to the east end, an additional pump will be needed. This pump will need to be able to overcome a 10 foot elevation difference as well as any head from the rapid mix basin. The water to be pumped will have already undergone treatment via a grit chamber and clarifier so a centrifugal pump can be used. The capacity of the pump will need to be 500 gpm. The pump will be located behind the existing clarifier and will be mounted to building wall along with the return piping.

### 8.3. High Service Pump Station

In order to accommodate the installation of the UV reactors between the filters and high service pumps, a new high service pump station will be installed. Since the installation of the UV reactors will not have a significant impact on the design conditions for the downstream pumps, the high service pumps will match the existing pumps in capacity and design TDH as shown in Table 5-1. A more detailed evaluation of the hydraulics and requirements for the High Service Pump Station will be conducted during detailed design. Vertical turbine pumps will be used. The low pressure zone pumps will be installed in a wetwell configuration, and the high pressure zone pumps will be mounted in a can due to space constraints.

## 9. Site Design

---

### 9.1. Site Design Civil

To accommodate the proposed changes at the Temple WTP site, some modifications to the existing features will be needed. The site plan is shown in Figure 5-2. Due to site constraints, the existing planter area along the south edge of the filter building will be removed for construction of the proposed UV facility. The UV facility will be constructed immediately adjacent to the filter building, with minimum separation for construction and placement of sheeting and shoring, and as required for seismic design of the facility. The existing high pressure zone and low pressure zone pumps will be replaced and relocated to accommodate the hydraulics of the proposed UV facility.

Other site modifications include miscellaneous paving demolition and replacement, replacement of site fencing if needed, and minor site grading for drainage.

# 10. Design Specialties

---

## 10.1. Introduction

The proposed site structures include the UV building, high service pump station, grit chamber, and the containment areas for the sodium hypochlorite and ammonia. The containment areas will be covered by a painted steel canopy and surrounded by privacy fencing. The UV building will be an enclosed concrete masonry unit (CMU) building with a flat built up roof.

## 10.2. Structural

### 10.2.1. General

The structural design for the UV Building, containment areas for the sodium hypochlorite and ammonia, and the canopy will be designed to comply with the latest applicable building and materials codes as follows:

- 2007 California Building Code and Applicable Local Building Codes
- Code Requirements for Reinforced Concrete (ACI 318-05)
- Code Requirements for Environmental Engineering Concrete Structures and Commentary (ACI 350-06)
- Code Requirements for Masonry Structures (ACI 530-05)
- Specification for Structural Steel Buildings (ANSI/AISC 360-05)
- Standard Specification for Open Web Steel Joists.

### 10.2.2. UV Building

The UV Building will be a two story structure with the bottom level consisting of a below grade cast-in-place concrete structure. The bottom level will support the building wall for the top level. This is based on the assumption that the existing soils are adequate to support the building loads. The allowable bearing design pressures will be confirmed as a part of the soils investigation. A cast-in-place concrete slab will be provided for the support of equipment and piping within the building for both levels.

The top level will have masonry walls that will be designed to provide support for the roof as well as provide lateral resistance to the wind and seismic loads. The masonry walls will be reinforced as required to provide adequate strength to resist the code mandated loads.

The flat roof system will consist of open web steel joists that will span the length of the building. The joists will support the roof live and dead loads with the depth of the joists

sufficient to minimize the live load deflections per the requirements of the code. Steel roof deck will be designed to span between the joists to support the roof dead and live loads. The painted steel roof deck also acts as a diaphragm to transfer the lateral loads from top of the masonry walls to the masonry shear walls.

### 10.2.3. Chemical Containment Area and Canopy

The containment area will consist of a cast-in-place concrete slab with containment walls. The slab will be designed to support the weight of the chemical tanks and equipment. The canopy will consist of a pre-engineered painted steel canopy with privacy fencing. The shallow sloped roof will be constructed of steel roof purlins and painted steel roof deck. The foundation system for the canopy steel support columns will consist of individual concrete footings properly sized to support the roof loading.

## 10.3. Architectural

The building will utilize concrete masonry unit (CMU) construction. The CMU materials will match the existing appearance of the filtration building. A single ply roof installed on a flat metal decking below a parapet wall will be provided. The roof will slope to scuppers and downspouts for drainage.

The UV Facility will be designed based on a 2007 California Building Code (CBC) Factory Industrial Group F-2 building classification corresponding to a Low-Hazard occupancy. The chemical storage areas will be designed based on a High-Hazard Group H-3 building classification. Sodium hypochlorite is a moderate oxidizer and corrosive. Aqueous ammonia is a weak base. Table 10-1 provides additional details regarding the building classifications.

**Table 10-1.  
Building Classification Summary**

Building	UV Facility	Chemical Containment Areas
Design Code	2007 CBC	2007 CBC
Building Occupancy Classification	Group F-2 (2007 CBC Chapter 3)	Group H-3
Type of Construction	II (2007 CBC Chapter 6)	NA
Approximate Area	700 SF	1,000 SF
Approximate Height	12 feet	20 feet
Fire Suppression System	NA	Sprinklers

## 10.4. Instrumentation and Control

### 10.4.1. Control System Philosophy/System Architecture

New UV facilities will have a PLC-based control panel (MCP) and individual local control panels (PLC-based or Non-PLC based) for each sub-facility.

The MCP will be located in the UV building. Monitoring and control of new UV facilities will be done in existing control room. Communication type between MCP and existing SCADA will depend on existing network capabilities and will be determined during detailed design.

### **UV Reactors**

Each UV reactor will have a vendor supplied local HMI unit at the reactor and a vendor supplied PLC-based field control panel (FCP) which will communicate with the MCP via Ethernet or Modbus protocol. Provisions for local control are included at the HMI.

### **High Service Pumps**

The High Service Booster pumps will be controlled manually from the VFD panel and automatically from MCP. VFD panel will include Hand/off/Remote switch, reset switch, on and overload status for manual operation and monitoring. Remote monitoring will be done at operator workstation (HMI) in the existing control room.

### **Chemical metering pumps**

Each set of chemical metering pumps, chemical transfer pumps and storage tanks will have a field control panel for local operation and monitoring and will be hardwired to the MCP for automatic control. Remote monitoring will be done at the operator workstation in the existing control room or at CICO offices via SCADA.

All other field instruments and valve actuators will be hardwired to the MCP for monitoring and control.

## **10.4.2. Hardware and software concept/configuration**

The MCP will be a PLC-based control system. The PLC system will be Modicon or Allen Bradley PLC. Depending on existing network capabilities, MCP will communicate with existing SCADA or will be connected to a new operator workstation in the existing control room. MCP will also communicate with UV reactor control panels via Modbus or Ethernet. Communication protocol will be verified during detail design.

The UV reactor control panels are PLC-based and will be provided by the UV vendor. Operator Interface Terminal (OIT) can be located in UV reactor control panel inside electrical room or locally close to the reactor.

Filed Control Panels for chemical transfer and metering pumps are relay based and will include necessary pushbutton and lights and process indicators. These FCPs will be hardwired to the MCP for monitoring and automatic control.

In following section, HMI denotes the operator workstation in existing SCADA and OIT denotes local HMI for UV reactors.

### 10.4.3. Preliminary Control Strategies

#### Chemical Storage Tank

1. Overview:

Storage tanks will be provided for sodium hypochlorite and aqueous ammonia storage. The station is equipped with a field control panel for each tank which provides audible and visual alarms and appropriate warning signals in SCADA.

2. Monitoring and Control:

The chemical tanks are provided with an ultrasonic level transmitter and a high-high level switch. The level transmitter transfers a signal to the field control panel (FCP) and will be repeated to the MCP for indication of tank level on HMI and SCADA.

High-high level switch will be connected to the FCP for local alarm and will be sent back to MCP for remote alarm on HMI.

New hypochlorite storage tank will have a low-low level switch hardwired to hypochlorite transfer pumps FCP to shutdown the pumps at low-low level. This signal will be repeated to MCP for low-low level alarm on HMI.

The 4-20mA signal will also be utilized to develop three separate setpoints through PLC software switches in the MCP (High, Low and Low-Low). High and Low level switches will be used for alarm annunciation, and the Low-Low level switch will be used for feed pump shut down. The setpoints will be determined during final design based on storage tank selection.

Ammonia storage tank will be equipped with pressure and temperature transmitters which will be connected to MCP for indication of tank temperature and pressure on HMI.

3. Local Display/Control:

- Instrument Display:

Tank Level indication

- Field Control Panel:

Tank Level digital indicator

Silence pushbutton

Reset pushbutton

- Alarms on FCP:



High-High Level light, beacon

4. Remote Manual Control (HMI):

N/A

5. Remote Auto Control (MCP):

N/A

6. Interlocks and IO from other processes

- Feed pump(s) shutdown on low-low tank level signal for ammonia tank.
- Transfer Pump(s) shutdown on low-low tank level signal for hypochlorite tank.

7. HMI generated signal and indications

- Storage Tank Continuous Level Indication
- Storage Tank Level High
- Storage Tank Level Low
- Storage Tank Level Low-Low
- Storage Tank Level High-High
- Storage Tank Pressure (Ammonia only)
- Storage Tank Pressure High (Ammonia only)
- Storage Tank Pressure Low (Ammonia only)
- Storage Tank Temperature (Ammonia only)

### **Hypochlorite Transfer Pumps**

1. Overview:

Two hypochlorite transfer pumps (main and standby) will be used to feed the chlorine from the new storage tank to the existing storage tank. Operator will assign main and standby pumps at the HMI.

2. Monitoring and Control:

Field instruments used for controlling the transfer pumps will include:

- Pressure switches on the pump's inlet and outlet
- Level transmitter and level switch on the new and existing Hypochlorite storage tank

The transfer pumps will be operated in manual mode only. In manual mode (local at FCP or remote at HMI), the pump start/stop will be controlled by the operator. The Low and High pressure switches at the pump's inlet and outlet will initiate alarm at HMI. The transfer pump will be stopped on Low-Low level signal from the new storage tank, High-High level from the existing storage tank, Low pressure signal from the pump suction, or on High pressure signal from the pump discharge to protect the system and transfer pump.

3. Local Display/Control:

At Field Control Panel:

Hand/Remote mode will be locally selected by the operator on the Field Control panel. In hand mode, the operator will start and stop the pump from the FCP.

Alarms and display at FCP for the transfer pumps:

- Pump overload light
- Pump suction low pressure light
- Pump discharge high pressure light
- Reset button for alarm lights
- Existing Storage Tank low level
- New Storage Tank high level

4. Remote Manual Control (HMI):

In Remote Manual mode, the operator will start/stop the transfer pumps.

5. Interlocks and IO from other processes

- Shutdown on Low-Low level from the existing storage tank, High-high level from new storage, Low pressure signal from the pump suction, or on High pressure signal from the pump discharge.

6. HMI generated alarms and indications

- Pump No 1, 2 On
- Pump No 1, 2 Overload
- Pump No 1, 2 in Remote
- Pump No.1, 2 Inlet Pressure Low

- Pump No.1, 2 Outlet Pressure High

### **Hypochlorite Feed Pumps**

#### 1. Overview:

Four hypochlorite feed pumps will be installed and configured in two sets. The first set will be used to feed the chlorine from the existing storage tank to the existing addition points. Second set will be used to feed chlorine to the new addition points. Operator will assign main and standby pumps for each set at the HMI.

#### 2. Monitoring and Control:

Field instruments used for controlling the feed pumps will include:

- Water flow meters in the UV Building
- Total chlorine analyzers
- Pressure switches on the feed pump's inlet and outlet
- Level transmitter on the Hypochlorite storage tank

In remote auto mode, the pump speed control will be based on flow pacing or the chlorine residual. When selected for flow pacing the pump speed will be based on a dosage setpoint and the total water flow rate measured as the sum of the flow meters on the UV reactors outlet. When selected for residual control, the pump speed will be based on a chlorine residual setpoint and the chlorine residual signal from the analyzer.

In manual mode (local or remote), the pump speed will be adjusted by the operator. The chlorine analyzer will have two separate setpoints (Low and High software switches). The Low and High setpoints will initiate alarm at HMI. The chlorine feed pump will be stopped on Low-Low level signal from the storage tank, on leak detection signal from leak detector on the pump, on Low pressure signal from the feed pump suction, or on High pressure signal from the feed pump discharge to protect the system and feed pump.

#### 3. Local Display/Control:

At pump:

Local/Remote mode will be locally selected by the operator on the feed pump local panel/keypad. In local mode, the operator will adjust the feed pump speed at the individual pumps. The running, speed indication, and fault status are displayed on the pump local VFD panel/keypad.

At Field Control Panel:

Hardwired interlock will be implemented in FCP to stop the feed pumps on low suction pressure, high discharge pressure or pump leak detection.

Alarms at FCP for the feed pumps:

- Pump leak detection light
- Pump suction low pressure light
- Pump discharge high pressure light
- Reset button for alarm lights

4. Remote Manual Control (HMI):

The operator can select auto or manual mode. In manual mode the pump speed will be adjusted by the operator.

5. Remote Auto Control (PLC):

In Auto mode, the operator selects either residual or flow paced control. In flow paced control the operator selects a dosage setpoint, which would be converted to speed by PLC and sent to the pump. In residual based control the operator selects a target residual and the pump speed is adjusted based on the residual measured by the chlorine analyzer. The operator can also set Pump 1 or 2 as main or Standby.

The following signals will be sent from each pump to the PLC:

- In Remote
- Speed
- Trouble
- On

The following commands will be sent to the pump in remote mode:

- Run
- Dosing rate

When the operator selects auto in remote mode, “Run” and “Dosing rate” command will be sent to the main feed pump which is selected to be Pump 1 or 2 by the operator. If the main pump has stopped due to any failure, the standby pump will be started and speed control resumed.

6. Interlocks and IO from other processes

- Shutdown on Low-Low level from the storage tank, Pump Leak detection, Low feed pump suction pressure and High feed pump discharge pressure.

7. HMI generated alarms and indications

- Pump No 1, 2 On

- Pump No 1, 2 Trouble
- Pump No 1, 2 Speed
- Pump No 1, 2 in Remote/Local
- Pump No 1, 2 in Auto/Manual
- Pump No.1, 2 Leak Detected
- Pump No.1, 2 Inlet Pressure Low
- Pump No.1, 2 Outlet Pressure High
- Chlorine High
- Chlorine Low

### **Ammonia Feed Pumps**

#### 1. Overview:

Two ammonia feed pumps (main and standby) will be used to feed the ammonia from storage tank to the addition point. Operator can assign main and standby pumps at HMI.

#### 2. Monitoring and Control:

Field instruments & valve actuators used for controlling the feed pumps will include:

- Water Flow Meters in the UV Building
- Total chlorine analyzer
- Ammonia Analyzer
- Pressure switch on the feed pump's inlet and outlet
- Level transmitter on the ammonia storage tank

In remote auto mode, the pump speed control (dosing rate) shall either be flow paced based on total water flow rate measured as the sum of the flow meters on the UV reactor outlet or operate in a ratio control mode. In ratio control the ratio is set in relation to the measured chlorine residual prior to ammonia addition.

In manual mode (local or remote), the pump speed will be adjusted by the operator. The ammonia feed pump will be stopped on Low-Low level signal from the storage tank, on leak detection on the feed pump, on Low pressure signal from the feed pump suction, or on High pressure signal from the feed pump discharge to protect the system and feed pump.

#### 3. Local Display/Control:

At pump:

Local/Remote mode will be locally selected by the operator. In local mode, the operator will adjust the feed pump speed at pump local panel/keypad. In local mode,

operator will adjust the feed pump speed at the individual pumps. The run, speed indication, and fault status are displayed on the pump local panel/keypad.

#### At Field Control Panel

Hardwired interlock will be implemented in FCP to stop the feed pumps on low suction pressure, high discharge pressure or pump leak detection.

Following alarms will be provided at FCP with Reset pushbutton:

- Pump leak detection light
- Pump suction low pressure light
- Pump discharge high pressure light

#### 4. Remote Manual Control (HMI):

The operator can select auto or manual mode. In manual mode the pump speed will be adjusted by the operator at HMI.

#### 5. Remote Auto Control (PLC):

In Auto mode, the operator selects either ratio or flow paced control. In flow paced control the operator selects a dosage setpoint, which would be converted to speed by PLC and sent to the pump. In ratio based control the dosage is set based on the chlorine residual prior to the application point and a set ratio of ammonia to chlorine. The operator can also set Pump 1 or 2 as main or standby.

The following signals will be sent from each pump to the PLC:

- In Remote
- Speed
- Trouble
- On

The following commands will be sent to the pump in remote mode:

- Run
- Dosing rate

When the operator selects auto in remote mode, “Run” and “Dosing rate” command will be sent to the main feed pump which is selected to be Pump 1 or 2 by the operator. If the main pump has stopped due to any failure, the standby pump will be started and speed control resumed.

#### 6. Interlocks and IO from other processes

- Shutdown on Low-Low level from the storage tank, Leak Detector on the feed pump, Low feed pump suction pressure, High feed pump discharge pressure.

7. HMI generated alarms and indications

- Pump No 1, 2 Pump On
- Pump No 1, 2 Trouble
- Pump No 1, 2 Speed
- Pump No 1, 2 in Remote/Local
- Pump No 1, 2 in Auto/Manual
- Pump No 1, 2 Leak detected
- Pump No 1, 2 Inlet Pressure Low
- Pump No 1, 2 Outlet Pressure High
- Ammonia High

**UV System**

1. Overview

The UV system consists of the UV reactors and associated equipment and instruments to monitor and control the process.

2. Monitoring and Control:

Each UV reactor will have an associated control panel which will be furnished and programmed by the UV manufacturer. The UV control panel will communicate with the Master Control Panel (MCP) thru the communication network.

Field instruments & valve actuators used for controlling the UV reactors will include:

- Water flow meters in the UV Building
- Temperature switches on UV reactors
- Temperature transmitter on UV reactors
- Level switch on UV reactors
- UVT transmitter on wet well

**UV Control Panel**

This panel will be furnished and programmed by the UV manufacturer. Auto/Manual and Local/Remote selector switches shall be provided for each reactor to control reactor function:

- In Remote mode, reactor will be controlled/monitored by MCP/HMI. In Local mode, operator can select “Auto” or “Manual” mode.
- In the “Manual” mode, reactors will operate independent of the MCP at a constant lamp power setting. This lamp power setting shall be operator adjustable.

- In the “Auto” mode, reactors will dose pace (based on a validated dose setpoint) in response to a system flow rate signal, a UVT signal, and UV sensor measurements. A signal shall be transmitted to the MCP when the reactor is in the “Auto” mode.

The dose pacing system shall function in conjunction with the signal from the UVT analyzer, flow meter, and UV sensors. The system shall be dose-paced such that as the flow, UV sensor intensity, and UVT change, the validated dose delivered is optimized and meets the required setpoint. The validated dose shall never go below the validated dose setpoint. The UV control panel shall automatically adjust the validated dose through modulation of the power to the reactor lamps to meet the validated dose setpoint.

Logic and time delays shall be provided to regulate the UV reactor On/Off cycle to prevent excessive cycling on both start-up and shutdown of the UV reactors.

**UV Intensity Monitoring:**

A UV sensor will be furnished for each lamp. The intensity sensor will continuously monitor the UV intensity of the lamps. UV intensity in milliwatts per centimeter will be indicated on the OIT of the reactor and also will be sent to MCP to be displayed on the HMI.

**On-Line UV Transmittance Analyzer:**

An on-line UVT analyzer will be provided to automatically track the transmittance of the water at 253.7 nm.

The following signals will be sent from MCP to UV control panel via communication network:

- Flow rate
- UVT
- On/Off command
- Validated dose setpoint
- Cleaning mechanism frequency
- Emergency stop
- Validation factor setpoint (if not calculated by FCP)

Following signals will be sent from UV control panel to MCP via communication network:

- Validated dose
- Calculated RED (if applicable)
- Calculated validation factor
- Lamp/electrical compartment door access
- UV sensor readings for all lamps
- Cleaning mechanism status and position
- Cleaning cycle counts



- Reactor on/off
- Reactor ready
- Lamp current
- Individual lamp run hours – resettable and non-resettable
- Individual lamp starts– resettable and non-resettable
- Lamp status
- Lamp power setting
- Electrical compartment door access
- Emergency stop condition
- Auto or Manual Mode
- Alarms (see item 7 below)

#### Master Control Panel

- The operator can select local or remote mode from OIT at the reactor. In remote mode the on/off control of each UV reactor will be done with the MCP.
- Operator can assign main and standby reactors at HMI.
- In the event of a voltage interruption or sag that is not covered by the UPS and results in the main reactor losing arc and shutting down, the standby UV reactor will be energized (as opposed to the UV reactor that was energized before the power quality event).
- When reactor outlet control valve and UV drain valve are in remote position, UV startup phase can be controlled by the MCP. The MCP will open the individual UV drain valve as required for the selected reactor during the start-up of each individual UV reactor. The valve will open on an adjustable time delay. The UV drain valve will close and the reactor outlet valve will open based on this time delay.
- The normal operating mode of the UV reactors is remote mode which must be selected at UV reactor OIT, UV outlet valve and UV drain valve

#### 3. Local Display/Control (OIT):

Local display and control including local/remote and auto/manual selection will be done at OIT at each reactor.

#### 4. Remote Manual Control (HMI):

When Remote mode is selected at UV reactor OIT, the operator can select auto or manual mode at the HMI (in existing control room). In remote manual mode, the dose setpoint will be adjusted by the operator and sent to the UV reactor control panel and the UV reactors will be operated at an adjustable constant lamp power as described above. The operator can also set the reactors as main or standby.

#### 5. Remote Auto Control (PLC):

In remote auto mode, validated dose setpoint will be sent from MCP to the UV reactor control panel and the UV reactors will be operated using dose pacing to vary power based on signal from the UVT analyzer, flow meter, and UV sensors as described above.

6. Interlocks and IO from other processes

High Temperature Switch:

- Each reactor shall be equipped with a switch that automatically shuts down the reactor when the internal temperature in the reactor exceeds 50° C.
- When the high temperature switch is triggered on a reactor, a manual reset at the OIT shall be performed to restart the reactor.

7. Alarms and indications

The following alarms shall be integrated into the UV control panel and OIT:

- Lamp failure
- Ballast failure
- Ballast high temperature
- GFI failure
- Low UV intensity
- Low calculated/validated UV dose
- Reactor high water temperature
- Time to check UV sensor calibration
- Lamp runtime hours exceeded
- Wiper failure
- Low water level
- Low UVT
- High flow rate
- Electrical cabinet high temperature

### **High Service Pumps**

1. Overview:

Five variable speed high service pumps will be used to supply the distribution system. Two pumps are dedicated to the high pressure system and three are dedicated to the low pressure system. Operator can assign lead/lag and standby pumps at HMI.

2. Monitoring and Control:

Field instruments & valve actuators used for controlling the feed pumps will include:

- Downstream Pressure Transmitter
- Level transmitter in the wet well
- Pressure switch on the feed pump's outlet

In remote auto mode, the pump speed control shall be based on a downstream pressure setpoint and wet well level. The pump speed and number of pumps in service will vary based on the wet well level.

In remote manual mode, the pump speed will be controlled by the operator.

In local mode, the pump speed will be controlled at the pump's VFD panel.

### 3. Local Display/Control at VFD panel:

Operator can place the pump in local or remote and start and stop the pump and set pump speed.

Indicator/Status light

- Pump speed
- On
- Ready

Alarms

- High wet well level
- Low wet well level
- High discharge pressure

### 4. Remote Manual Control (HMI):

Operator can start and stop the pump and set the pump speed.

### 5. Remote Auto Control (MCP):

Operator enters a discharge pressure setpoint for the pumps to maintain and a dead band. The number of pumps in service and pump speed varies based on wet well level. As wet well level rises pump speed is increased and as needed more pumps are placed in service, as wet well level drops pump speed is decreased and as-needed pumps are taken out of service.

### 6. Interlocks and IO from other processes

Pumps will be shutdown on Low-low wet well level or High-High discharge pressure.

### 7. HMI generated alarms and indications at HMI

- Pump No.1,2,3,4,5 on
- Pump No.1,2,3,4,5 ready
- Pump No.1,2,3,4,5 in remote
- Pump No.1,2,3,4,5 VFD trouble
- Pump No.1,2,3,4,5 high winding temperature
- Pump No.1,2,3,4,5 high moisture
- Pump No.1,2,3,4,5 speed
- Pump No.1,2,3,4,5 high discharge pressure
- High wet well level
- Low wet well level

## 10.5. Electrical

A detailed evaluation of the existing electrical feed to the site will be done during detailed design. It is anticipated that facilities will be served either from the existing utility connection or via a new underground service from a 12kv, 480/277-volt, 3-phase, 4-wire pad mount transformer. These potential power sources will be sized to feed the new power distribution system configuration that will be developed from the PDR review.

A motor control center with critical and non-critical busses will distribute power to facility electrical equipment. The UV reactors will be fed from a battery type uninterruptible power supply (UPS) via the critical section of the motor control center. The preliminary one-line diagram is shown on Drawing E-1 in Appendix A.

An emergency diesel generator, rated to serve the entire facility via an automatic transfer switch incorporated in the motor control center, will provide power during potential power outages. The generator will be designed with an integral double walled full tank. The amount of fuel storage will be determined during final design based on the desired operating period.

The UPS will maintain seamless constant operation of the UV reactors and associated critical instrumentation and equipment during the period between utility failure and generator on-line operation. This period is nominally less than 10 seconds. The electrical room layout is shown on Drawing M-4 of Appendix A.

During any momentary power fluctuation events such as voltage dips, voltage spikes and short term interruptions the Standby Generator/ UPS Combination will seamlessly provide rated power to the motor control center critical bus to maintain continuous operation of the UV reactors.

## 10.6. HVAC

The chemical facilities are not enclosed and the chemicals stored do not have heating or cooling requirements. The chemical facilities will not include any ventilation, heating or cooling equipment.

The UV Building will include the UV equipment, electrical equipment, and control equipment. The building will be separated into two areas: one with the UV equipment and one with the control panels, and electrical equipment. The equipment area will be ventilated with a minimum design ventilation rate of 6 air changes per hour. The electrical room will be equipped with an HVAC system to maintain the room at a comfortable temperature and ensure a maximum allowable temperature of 104 degrees F to protect the PLCs, UPS and VFDs.

## 10.7. Plumbing/Fire Suppression

### 10.7.1. Utility Water and Drainage

The chemical facilities will be equipped with four eyewash showers and a washdown station. The UV Building will also be equipped with a washdown station. The estimated total utility water demand is as shown in Table 10-2.

**Table 10-2.**  
**Utility Water Demand**

<b>Component</b>	<b>Flow Rate (gpm)</b>
Washdown Station (assume only one in use)	15
Eyewash/Shower	20
Total	35

The chemical areas will be equipped with a manually operated sump pump that will discharge either to a chemical waste truck if a spill occurs or to grade for disposal of rainwater. The UV building will have a drainage sump for the floor drains.

### 10.7.2. Fire Suppression

The Chemical building will include a wet pipe water based fire sprinkler system even though it is not required for the Group F-2 occupancy. The estimated total Fire Flow Demand is as shown in Table 10-3

**Table 10-3.  
Fire Flow Demand**

<b>Component</b>	<b>Flow Rate (gpm)</b>
Hydrant (assume only one in use)	500
Sprinkler System Chemical Building	500
Total	1,000

# 11. Impact to Existing Facilities

---

## 11.1. Impacts to Existing Facilities

The facilities will be constructed on-site adjacent to the existing facilities. The majority of the facilities can be constructed without impacting the operation of Temple WTP. A full shutdown of the Temple WTP will be required to modify the existing hypochlorite system and the existing tie-in to the piping on site. Electrical improvements will be required at the site. The connection into the existing electrical systems and shutdowns associated with this will be evaluated in detailed design.

## 12. Permitting

---

CICo as a water agency is generally exempt from obtaining county and city permits. CICo will need to verify their permitting arrangement with local agencies including the local fire department.

A permit to operate will be required from the California Department of Public Health (CDPH) for the facility.



---

***UV/CHLORAMINES PROJECT***

***TEMPLE WATER TREATMENT PLANT***

**PROJECT MANUAL**

---

**COVINA IRRIGATING COMPANY  
UV/CHLORAMINES PROJECT  
TEMPLE WATER TREATMENT PLANT  
GLEN DORA, CA**

**DECEMBER 2009**



**MALCOLM PIRNIE, INC.  
8001 Irvine Center Drive, Suite 1100  
Irvine, CA 92618**

---

# COVINA IRRIGATING COMPANY

---



[Contractor Name]  
[Address]  
[Address]  
[Address]

Dear Mr. [Ms, Mrs, etc]:

Your firm has been invited to bid for the construction contract of the UV/Chloramines Project at the Temple Water Treatment Plant in Glendora, CA. Sealed Bids for the construction of the UV/Chloramines Facility will be received, from invited bidders only, by the Covina Irrigating Company, at their office, until 1:00 PM Local Time on **February 16, 2010**, at which time they will be privately opened and read.

Bids shall be on a lump sum basis for the General Construction Contract.

Bidding Documents are enclosed with this letter; additional copies may be purchased for \$\_\_\_\_\_ per set from \_\_\_\_\_. Neither the Owner nor the Engineer will be responsible for full or partial sets of Bidding Documents, including any addenda, obtained from other sources.

Bid security shall be provided in accordance with Article 10 of the Instructions to Bidders.

Bidders shall provide proof of qualifications to perform the Work as described in Article 5 of the Instructions to Bidders.

Contract time of commencement and completion will be in accordance with Article 4 of the Agreement.

**Location & Description of the Work:**

The work is located on the site of Covina Irrigating Company's Temple Water Treatment Plant at 255 West Arrow Highway, Glendora, CA 91740. The project includes construction of a new UV treatment facility and pump station, a new chemical feed facility, and various site improvements. The new UV treatment facility and pump station will be a single sub-grade concrete structure with an above-ground air-conditioned masonry electrical building. The pump station will include five vertical turbine pumps of various sizes with a pre-fabricated metal canopy overhead and a wet well for storage of finished water. The new chemical feed facility will include a new FRP chemical storage tank, a new steel chemical storage tank, chemical feed pumps and piping, a concrete containment area, and pre-fabricated metal canopy. Chemical feed pumps and piping shall be installed within existing facilities and areas of the site

as well. Site improvements such as a new security fence and paving of the entire site are also included, as well as a new sand settling basin and installation of backwash recycle pumps.

**Questions:**

For questions related to the project or regarding this bidding process, please contact the Engineer:

Mark Strahota, PE  
Malcolm Pirnie, Inc.  
8001 Irvine Center Drive  
Suite 1100  
Irvine, CA 92618

All communications concerning this Invitation to Bid (ITB) must be in writing. Written questions regarding details of this ITB will be accepted (i.e., must be received) by the Engineer until 5:00 P.M., Pacific Standard Time (PST), **February 5, 2010**. Written questions must be sent via standard mail to the address above, via facsimile at (949) 450-9902, or via electronic telecommunication (email) at [mstrahota@pirnie.com](mailto:mstrahota@pirnie.com). All questions submitted to the Engineer's street address or by facsimile shall contain the following title in the inquiry; questions submitted via e-mail shall contain the following title in the Subject line: "UV/Chloramines Project: Bidder Questions." Telephone questions will not be accepted. Any questions received after the indicated date may not receive a response.

Sincerely,

David D. De Jesus  
President  
Covina Irrigating Company

**GENERAL CONDITIONS  
OF THE CONSTRUCTION CONTRACT**

Adapted from Standard General Conditions of the  
Construction Contract, EJCDC No. C-700 (2002 Edition).

[This page was left blank intentionally.]

## TABLE OF CONTENTS

	<u>Page</u>
ARTICLE 1 - DEFINITIONS AND TERMINOLOGY .....	00710 - 7
1.01 <i>Defined Terms</i> .....	00710 - 7
1.02 <i>Terminology</i> .....	00710 - 10
ARTICLE 2 - PRELIMINARY MATTERS .....	00710 - 11
2.01 <i>Delivery of Bonds and Evidence of Insurance</i> .....	00710 - 11
2.02 <i>Copies of Documents</i> .....	00710 - 12
2.03 <i>Commencement of Contract Times; Notice to Proceed</i> .....	00710 - 12
2.04 <i>Starting the Work</i> .....	00710 - 12
2.05 <i>Before Starting Construction</i> .....	00710 - 12
2.06 <i>Preconstruction Conference</i> .....	00710 - 12
2.07 <i>Initial Acceptance of Schedules</i> .....	00710 - 12
ARTICLE 3 - CONTRACT DOCUMENTS: INTENT, AMENDING, REUSE .....	00710 - 13
3.01 <i>Intent</i> .....	00710 - 13
3.02 <i>Reference Standards</i> .....	00710 - 13
3.03 <i>Reporting and Resolving Discrepancies</i> .....	00710 - 13
3.04 <i>Amending and Supplementing Contract Documents</i> .....	00710 - 14
3.05 <i>Reuse of Documents</i> .....	00710 - 14
3.06 <i>Electronic Data</i> .....	00710 - 15
ARTICLE 4 - AVAILABILITY OF LANDS; SUBSURFACE AND PHYSICAL CONDITIONS; REFERENCE POINTS .....	00710 - 15
4.01 <i>Availability of Lands</i> .....	00710 - 15
4.02 <i>Subsurface and Physical Conditions</i> .....	00710 - 15
4.03 <i>Differing Subsurface or Physical Conditions</i> .....	00710 - 16
4.04 <i>Underground Facilities</i> .....	00710 - 17
4.05 <i>Reference Points</i> .....	00710 - 18
4.06 <i>Hazardous Environmental Condition at Site</i> .....	00710 - 18
ARTICLE 5 - BONDS AND INSURANCE .....	00710 - 19
5.01 <i>Performance, Payment, and Other Bonds</i> .....	00710 - 19
5.02 <i>Licensed Sureties and Insurers</i> .....	00710 - 20
5.03 <i>Certificates of Insurance</i> .....	00710 - 20
5.04 <i>Contractor's Liability Insurance</i> .....	00710 - 20
5.05 <i>Owner's Liability Insurance</i> .....	00710 - 21
5.06 <i>Property Insurance</i> .....	00710 - 21
5.07 <i>Waiver of Rights</i> .....	00710 - 21
5.08 <i>Receipt and Application of Insurance Proceeds</i> .....	00710 - 21
5.09 <i>Acceptance of Bonds and Insurance; Option to Replace</i> .....	00710 - 21
5.10 <i>Partial Utilization Acknowledgment of Property Insurer</i> .....	00710 - 21
ARTICLE 6 - CONTRACTOR'S RESPONSIBILITIES .....	00710 - 22
6.01 <i>Supervision and Superintendence</i> .....	00710 - 22
6.02 <i>Labor; Working Hours</i> .....	00710 - 22
6.03 <i>Services, Materials, and Equipment</i> .....	00710 - 22
6.04 <i>Progress Schedule</i> .....	00710 - 23
6.05 <i>Substitutes and "Or-Equals"</i> .....	00710 - 23
6.06 <i>Concerning Subcontractors, Suppliers, and Others</i> .....	00710 - 25
6.07 <i>Patent Fees and Royalties</i> .....	00710 - 26
6.08 <i>Permits</i> .....	00710 - 26
6.09 <i>Laws and Regulations</i> .....	00710 - 26

TABLE OF CONTENTS (Continued)

	<u>Page</u>
6.10	<i>Taxes</i> .....00710 - 27
6.11	<i>Use of Site and Other Areas</i> .....00710 - 27
6.12	<i>Record Documents</i> .....00710 - 28
6.13	<i>Safety and Protection</i> .....00710 - 28
6.14	<i>Safety Representative</i> .....00710 - 28
6.15	<i>Hazard Communication Programs</i> .....00710 - 29
6.16	<i>Emergencies</i> .....00710 - 29
6.17	<i>Shop Drawings and Samples</i> .....00710 - 29
6.18	<i>Continuing the Work</i> .....00710 - 30
6.19	<i>Contractor's General Warranty and Guarantee</i> .....00710 - 31
6.20	<i>Indemnification</i> .....00710 - 31
6.21	<i>Delegation of Professional Design Services</i> .....00710 - 32
ARTICLE 7 - OTHER WORK .....00710 - 32	
7.01	<i>Related Work at Site</i> .....00710 - 32
7.02	<i>Legal Relationships</i> .....00710 - 33
ARTICLE 8 - OWNER'S RESPONSIBILITIES.....00710 - 33	
8.01	<i>Communications to Contractor</i> .....00710 - 33
8.02	<i>Furnish Data</i> .....00710 - 33
8.03	<i>Pay When Due</i> .....00710 - 33
8.04	<i>Lands and Easements; Reports and Tests</i> .....00710 - 33
8.05	<i>Insurance</i> .....00710 - 34
8.06	<i>Change Orders</i> .....00710 - 34
8.07	<i>Inspections, Tests, and Approvals</i> .....00710 - 34
8.08	<i>Limitations on Owner's Responsibilities</i> .....00710 - 34
8.09	<i>Undisclosed Hazardous Environmental Condition</i> .....00710 - 34
8.10	<i>Evidence of Financial Arrangements</i> .....00710 - 34
ARTICLE 9 - ENGINEER'S STATUS DURING CONSTRUCTION .....00710 - 34	
9.01	<i>Owner's Representative</i> .....00710 - 34
9.02	<i>Visits to Site</i> .....00710 - 34
9.03	<i>Project Representative</i> .....00710 - 35
9.04	<i>Authorized Variations in Work</i> .....00710 - 35
9.05	<i>Rejecting Defective Work</i> .....00710 - 35
9.06	<i>Shop Drawings, Change Orders and Payments</i> .....00710 - 35
9.07	<i>Determinations for Unit Price Work</i> .....00710 - 35
9.08	<i>Decisions on Requirements of Contract Documents and Acceptability of Work</i> .....00710 - 36
9.09	<i>Limitations on Engineer's Authority and Responsibilities</i> .....00710 - 36
ARTICLE 10 - CHANGES IN THE WORK; CLAIMS .....00710 - 37	
10.01	<i>Authorized Changes in the Work</i> .....00710 - 37
10.02	<i>Unauthorized Changes in the Work</i> .....00710 - 37
10.03	<i>Execution of Change Orders</i> .....00710 - 37
10.04	<i>Notification to Surety</i> .....00710 - 37
10.05	<i>Claims</i> .....00710 - 37

## TABLE OF CONTENTS (Continued)

	<u>Page</u>
ARTICLE 11 - COST OF THE WORK; ALLOWANCES; UNIT PRICE WORK .....	00710 - 38
11.01 <i>Cost of the Work</i> .....	00710 - 38
11.02 <i>Allowances</i> .....	00710 - 40
11.03 <i>Unit Price Work</i> .....	00710 - 41
ARTICLE 12 - CHANGE OF CONTRACT PRICE; CHANGE OF CONTRACT TIMES.....	00710 - 42
12.01 <i>Change of Contract Price</i> .....	00710 - 42
12.02 <i>Change of Contract Times</i> .....	00710 - 43
12.03 <i>Delays</i> .....	00710 - 43
ARTICLE 13 - TESTS AND INSPECTIONS; CORRECTION, REMOVAL OR ACCEPTANCE OF DEFECTIVE WORK .....	00710 - 43
13.01 <i>Notice of Defects</i> .....	00710 - 43
13.02 <i>Access to Work</i> .....	00710 - 43
13.03 <i>Tests and Inspections</i> .....	00710 - 44
13.04 <i>Uncovering Work</i> .....	00710 - 44
13.05 <i>Owner May Stop the Work</i> .....	00710 - 45
13.06 <i>Correction or Removal of Defective Work</i> .....	00710 - 45
13.07 <i>Correction Period</i> .....	00710 - 45
13.08 <i>Acceptance of Defective Work</i> .....	00710 - 46
13.09 <i>Owner May Correct Defective Work</i> .....	00710 - 46
ARTICLE 14 - PAYMENTS TO CONTRACTOR AND COMPLETION.....	00710 - 47
14.01 <i>Schedule of Values</i> .....	00710 - 47
14.02 <i>Progress Payments</i> .....	00710 - 47
14.03 <i>Contractor's Warranty of Title</i> .....	00710 - 49
14.04 <i>Substantial Completion</i> .....	00710 - 49
14.05 <i>Partial Utilization</i> .....	00710 - 50
14.06 <i>Final Inspection</i> .....	00710 - 50
14.07 <i>Final Payment</i> .....	00710 - 50
14.08 <i>Final Completion Delayed</i> .....	00710 - 51
14.09 <i>Waiver of Claims</i> .....	00710 - 52
ARTICLE 15 - SUSPENSION OF WORK AND TERMINATION .....	00710 - 52
15.01 <i>Owner May Suspend Work</i> .....	00710 - 52
15.02 <i>Owner May Terminate for Cause</i> .....	00710 - 52
15.03 <i>Owner May Terminate For Convenience</i> .....	00710 - 53
15.04 <i>Contractor May Stop Work or Terminate</i> .....	00710 - 53
ARTICLE 16 - DISPUTE RESOLUTION .....	00710 - 54
16.01 <i>Methods and Procedures</i> .....	00710 - 54
ARTICLE 17 - MISCELLANEOUS.....	00710 - 54
17.01 <i>Giving Notice</i> .....	00710 - 54
17.02 <i>Computation of Times</i> .....	00710 - 54
17.03 <i>Cumulative Remedies</i> .....	00710 - 54
17.04 <i>Survival of Obligations</i> .....	00710 - 54
17.05 <i>Controlling Law</i> .....	00710 - 55
17.06 <i>Headings</i> .....	00710 - 55



# GENERAL CONDITIONS

## ARTICLE 1 - DEFINITIONS AND TERMINOLOGY

### 1.01 *Defined Terms*

- A. Wherever used in the Bidding Requirements or Contract Documents and printed with initial capital letters, the terms listed below will have the meanings indicated which are applicable to both the singular and plural thereof. In addition to terms specifically defined, terms with initial capital letters in the Contract Documents include references to identified articles and paragraphs, and the titles of other documents or forms.
1. *Addenda* - Written or graphic instruments issued prior to the opening of Bids which clarify, correct, or change the Bidding Requirements or the proposed Contract Documents.
  2. *Agreement* - The written instrument which is evidence of the agreement between Owner and Contractor covering the Work.
  3. *Application for Payment* - The form acceptable to Engineer which is to be used by Contractor during the course of the Work in requesting progress or final payments and which is to be accompanied by such supporting documentation as is required by the Contract Documents.
  4. *Asbestos* - Any material that contains more than one percent asbestos and is friable or is releasing asbestos fibers into the air above current action levels established by the United States Occupational Safety and Health Administration.
  5. *Bid* - The offer or proposal of a Bidder submitted on the prescribed form setting forth the prices for the Work to be performed.
  6. *Bidder* - The individual or entity who submits a Bid directly to Owner.
  7. *Bidding Documents* - The Bidding Requirements and the proposed Contract Documents (including all Addenda).
  8. *Bidding Requirements* - The Advertisement or Invitation to Bid, Instructions to Bidders, bid security of acceptable form, if any, and the Bid Form with any supplements.
  9. *Change Order* - A document recommended by Engineer which is signed by Contractor and Owner and authorizes an addition, deletion, or revision in the Work or an adjustment in the Contract Price or the Contract Times, issued on or after the Effective Date of the Agreement.
  10. *Claim* - A demand or assertion by Owner or Contractor seeking an adjustment of Contract Price or Contract Times, or both, or other relief with respect to the terms of the Contract. A demand for money or services by a third party is not a Claim.
  11. *Contract* - The entire and integrated written agreement between the Owner and Contractor concerning the Work. The Contract supersedes prior negotiations, representations, or agreements, whether written or oral.
  12. *Contract Documents* - Those items so designated in the Agreement. Only printed or hard copies of the items listed in the Agreement are Contract Documents. Approved Shop Drawings, other Contractor's submittals, and the reports and drawings of subsurface and physical conditions are not Contract Documents.
  13. *Contract Price* - The moneys payable by Owner to Contractor for completion of the Work in

accordance with the Contract Documents as stated in the Agreement (subject to the provisions of Paragraph 11.03 in the case of Unit Price Work).

14. *Contract Times* - The number of days or the dates stated in the Agreement to: (i) achieve Milestones, if any, (ii) achieve Substantial Completion; and (iii) complete the Work so that it is ready for final payment as evidenced by Engineer's written recommendation of final payment.
15. *Contractor or CONTRACTOR* - The individual or entity with whom Owner has entered into the Agreement.
16. *Cost of the Work* - See Paragraph 11.01.A for definition.
17. *Drawings* - That part of the Contract Documents prepared or approved by Engineer which graphically shows the scope, extent, and character of the Work to be performed by Contractor. Shop Drawings and other Contractor submittals are not Drawings as so defined.
18. *Effective Date of the Agreement* - The date indicated in the Agreement on which it becomes effective, but if no such date is indicated, it means the date on which the Agreement is signed and delivered by the last of the two parties to sign and deliver.
19. *Engineer or ENGINEER* - The individual or entity named as such in the Agreement, or an authorized representative of the Owner.
20. *Field Order* - A written order issued by Engineer which requires minor changes in the Work but which does not involve a change in the Contract Price or the Contract Times.
21. *General Requirements* - Sections of Division 1 of the Specifications. The General Requirements pertain to all sections of the Specifications.
22. *Hazardous Environmental Condition* - The presence at the Site of Asbestos, PCBs, Petroleum, Hazardous Waste, or Radioactive Material in such quantities or circumstances that may present a substantial danger to persons or property exposed thereto in connection with the Work.
23. *Hazardous Waste* - The term Hazardous Waste shall have the meaning provided in Section 1004 of the Solid Waste Disposal Act (42 USC Section 6903) as amended from time to time.
24. *Laws and Regulations; Laws or Regulations* - Any and all applicable laws, rules, regulations, ordinances, codes, and orders of any and all governmental bodies, agencies, authorities, and courts having jurisdiction.
25. *Liens* - Charges, security interests, or encumbrances upon Project funds, real property, or personal property.
26. *Milestone* - A principal event specified in the Contract Documents relating to an intermediate completion date or time prior to Substantial Completion of all the Work.
27. *Notice of Award* - The written notice by Owner to the Successful Bidder stating that upon timely compliance by the Successful Bidder with the conditions precedent listed therein, Owner will sign and deliver the Agreement.
28. *Notice to Proceed* - A written notice given by Owner to Contractor fixing the date on which the Contract Times will commence to run and on which Contractor shall start to perform the Work under the Contract Documents.
29. *Owner or OWNER* - The individual or entity with whom Contractor has entered into the Agreement

and for whom the Work is to be performed.

30. *PCBs* - Polychlorinated biphenyls.
31. *Petroleum* - Petroleum, including crude oil or any fraction thereof which is liquid at standard conditions of temperature and pressure (60 degrees Fahrenheit and 14.7 pounds per square inch absolute), such as oil, petroleum, fuel oil, oil sludge, oil refuse, gasoline, kerosene, and oil mixed with other non-Hazardous Waste and crude oils.
32. *Progress Schedule* - A schedule, prepared and maintained by Contractor, describing the sequence and duration of the activities comprising the Contractor's plan to accomplish the Work within the Contract Times.
33. *Project* - The total construction of which the Work to be performed under the Contract Documents may be the whole, or a part.
34. *Project Manual* - The bound documentary information prepared for bidding and constructing the Work. A listing of the contents of the Project Manual, which may be bound in one or more volumes, is contained in the table(s) of contents.
35. *Radioactive Material* - Source, special nuclear, or byproduct material as defined by the Atomic Energy Act of 1954 (42 USC Section 2011 et seq.) as amended from time to time.
36. *Related Entity* - An officer, director, partner, employee, agent, consultant, or subcontractor.
37. *Resident Project Representative* - The authorized representative of Engineer who may be assigned to the Site or any part thereof.
38. *Samples* - Physical examples of materials, equipment, or workmanship that are representative of some portion of the Work and which establish the standards by which such portion of the Work will be judged.
39. *Schedule of Submittals* - A schedule, prepared and maintained by Contractor, of required submittals and the time requirements to support scheduled performance of related construction activities.
40. *Schedule of Values* - A schedule, prepared and maintained by Contractor, allocating portions of the Contract Price to various portions of the Work and used as the basis for reviewing Contractor's Applications for Payment.
41. *Shop Drawings* - All drawings, diagrams, illustrations, schedules, and other data or information which are specifically prepared or assembled by or for Contractor and submitted by Contractor to illustrate some portion of the Work.
42. *Site* - Lands or areas indicated in the Contract Documents as being furnished by Owner upon which the Work is to be performed, including rights-of-way and easements for access thereto, and such other lands furnished by Owner which are designated for the use of Contractor.
43. *Specifications* - That part of the Contract Documents consisting of written requirements for materials, equipment, systems, standards and workmanship as applied to the Work, and certain administrative requirements and procedural matters applicable thereto.
44. *Subcontractor* - An individual or entity having a direct contract with Contractor or with any other Subcontractor for the performance of a part of the Work at the Site.
45. *Substantial Completion* - The time at which the Work (or a specified part thereof) has progressed to

the point where, in the opinion of Engineer, the Work (or a specified part thereof) is sufficiently complete, in accordance with the Contract Documents, so that the Work (or a specified part thereof) can be utilized for the purposes for which it is intended. The terms “substantially complete” and “substantially completed” as applied to all or part of the Work refer to Substantial Completion thereof.

46. *Successful Bidder* - The Bidder submitting a responsive Bid to whom Owner makes an award.
47. *Supplementary Conditions* - That part of the Contract Documents which amends or supplements these General Conditions.
48. *Supplier* - A manufacturer, fabricator, supplier, distributor, materialman, or vendor having a direct contract with Contractor or with any Subcontractor to furnish materials or equipment to be incorporated in the Work by Contractor or any Subcontractor.
49. *Underground Facilities* - All underground pipelines, conduits, ducts, cables, wires, manholes, vaults, tanks, tunnels, or other such facilities or attachments, and any encasements containing such facilities, including those that convey electricity, gases, steam, liquid petroleum products, telephone or other communications, cable television, water, wastewater, storm water, other liquids or chemicals, or traffic or other control systems.
50. *Unit Price Work* - Work to be paid for on the basis of unit prices.
51. *Work* - The entire construction or the various separately identifiable parts thereof required to be provided under the Contract Documents. Work includes and is the result of performing or providing all labor, services, and documentation necessary to produce such construction, and furnishing, installing, and incorporating all materials and equipment into such construction, all as required by the Contract Documents.
52. *Work Change Directive* - A written statement to Contractor issued on or after the Effective Date of the Agreement and signed by Owner and recommended by Engineer ordering an addition, deletion, or revision in the Work, or responding to differing or unforeseen subsurface or physical conditions under which the Work is to be performed or to emergencies. A Work Change Directive will not change the Contract Price or the Contract Times but is evidence that the parties expect that the change ordered or documented by a Work Change Directive will be incorporated in a subsequently issued Change Order following negotiations by the parties as to its effect, if any, on the Contract Price or Contract Times.

#### 1.02 *Terminology*

- A. The following words or terms are not defined but, when used in the Bidding Requirements or Contract Documents, have the following meaning.
- B. *Intent of Certain Terms or Adjectives*
  1. The Contract Documents include the terms “as allowed,” “as approved,” “as ordered,” “as directed” or terms of like effect or import to authorize an exercise of professional judgment by Engineer. In addition, the adjectives “reasonable,” “suitable,” “acceptable,” “proper,” “satisfactory,” or adjectives of like effect or import are used to describe an action or determination of Engineer as to the Work. It is intended that such exercise of professional judgment, action or determination will be solely to evaluate, in general, the Work for compliance with the requirements of and information in the Contract Documents and conformance with the design concept of the completed Project as a functioning whole as shown or indicated in the Contract Documents (unless there is a specific statement indicating otherwise). The use of any such term or adjective is not intended to and shall not be effective to assign to Engineer any duty or authority to supervise or direct the performance of the

Work or any duty or authority to undertake responsibility contrary to the provisions of Paragraph 9.09 or any other provision of the Contract Documents.

C. *Day*

1. The word "day" means a calendar day of 24 hours measured from midnight to the next midnight.

D. *Defective*

1. The word "defective," when modifying the word "Work," refers to Work that is unsatisfactory, faulty, or deficient in that it:
  - a. does not conform to the Contract Documents, or
  - b. does not meet the requirements of any applicable inspection, reference standard, test, or approval referred to in the Contract Documents, or
  - c. has been damaged prior to Engineer's recommendation of final payment (unless responsibility for the protection thereof has been assumed by Owner at Substantial Completion in accordance with Paragraph 14.04 or 14.05).

E. *Furnish, Install, Perform, Provide*

1. The word "furnish," when used in connection with services, materials, or equipment, shall mean to supply and deliver said services, materials, or equipment to the Site (or some other specified location) ready for use or installation and in usable or operable condition.
2. The word "install," when used in connection with services, materials, or equipment, shall mean to put into use or place in final position said services, materials, or equipment complete and ready for intended use.
3. The words "perform" or "provide," when used in connection with services, materials, or equipment, shall mean to furnish and install said services, materials, or equipment complete and ready for intended use.
4. When "furnish," "install," "perform," or "provide" is not used in connection with services, materials, or equipment in a context clearly requiring an obligation of Contractor, "provide" is implied.

- F. Unless stated otherwise in the Contract Documents, words or phrases which have a well-known technical or construction industry or trade meaning are used in the Contract Documents in accordance with such recognized meaning.

## **ARTICLE 2 - PRELIMINARY MATTERS**

### 2.01 *Delivery of Bonds and Evidence of Insurance*

- A. When Contractor delivers the executed counterparts of the Agreement to Owner, Contractor shall also deliver to Owner such bonds as Contractor may be required to furnish.
- B. *Evidence of Insurance:* Before any Work at the Site is started, Contractor and Owner shall each deliver to the other, with copies to each additional insured identified in the Supplementary Conditions, certificates of insurance (and other evidence of insurance which either of them or any additional insured may reasonably request) which Contractor and Owner respectively are required to purchase and maintain in accordance with Article 5.

2.02 *Copies of Documents*

- A. Owner shall furnish to Contractor up to ten printed or hard copies of the Drawings and Project Manual. Additional copies will be furnished upon request at the cost of reproduction.

2.03 *Commencement of Contract Times; Notice to Proceed*

- A. The Contract Times will commence to run on the thirtieth day after the Effective Date of the Agreement or, if a Notice to Proceed is given, on the day indicated in the Notice to Proceed. A Notice to Proceed may be given at any time within 30 days after the Effective Date of the Agreement. In no event will the Contract Times commence to run later than the sixtieth day after the day of Bid opening or the thirtieth day after the Effective Date of the Agreement, whichever date is earlier.

2.04 *Starting the Work*

- A. Contractor shall start to perform the Work on the date when the Contract Times commence to run. No Work shall be done at the Site prior to the date on which the Contract Times commence to run.

2.05 *Before Starting Construction*

- A. *Preliminary Schedules:* Within 10 days after the Effective Date of the Agreement (unless otherwise specified in the General Requirements), Contractor shall submit to Engineer for timely review:
  - 1. a preliminary Progress Schedule;
  - 2. a preliminary Schedule of Submittals; and
  - 3. a preliminary Schedule of Values for all of the Work which includes quantities and prices of items which when added together equal the Contract Price and subdivides the Work into component parts in sufficient detail to serve as the basis for progress payments during performance of the Work. Such prices will include an appropriate amount of overhead and profit applicable to each item of Work.

2.06 *Preconstruction Conference*

- A. Before any Work at the Site is started, a conference attended by Owner, Contractor, Engineer, and others as appropriate will be held to establish a working understanding among the parties as to the Work and to discuss the schedules referred to in Paragraph 2.05.A, procedures for handling Shop Drawings and other submittals, processing Applications for Payment, and maintaining required records.

2.07 *Initial Acceptance of Schedules*

- A. At least 10 days before submission of the first Application for Payment a conference attended by Contractor, Engineer, and others as appropriate will be held to review for acceptability to Engineer as provided below the schedules submitted in accordance with Paragraph 2.05.A. Contractor shall have an additional 10 days to make corrections and adjustments and to complete and resubmit the schedules. No progress payment shall be made to Contractor until acceptable schedules are submitted to Engineer.
  - 1. The Progress Schedule will be acceptable to Engineer if it provides an orderly progression of the Work to completion within the Contract Times. Such acceptance will not impose on Engineer responsibility for the Progress Schedule, for sequencing, scheduling, or progress of the Work nor interfere with or relieve Contractor from Contractor's full responsibility therefor.
  - 2. Contractor's Schedule of Submittals will be acceptable to Engineer if it provides a workable arrangement for reviewing and processing the required submittals.

3. Contractor's Schedule of Values will be acceptable to Engineer as to form and substance if it provides a reasonable allocation of the Contract Price to component parts of the Work.

### **ARTICLE 3 - CONTRACT DOCUMENTS: INTENT, AMENDING, REUSE**

#### 3.01 *Intent*

- A. The Contract Documents are complementary; what is required by one is as binding as if required by all.
- B. It is the intent of the Contract Documents to describe a functionally complete Project (or part thereof) to be constructed in accordance with the Contract Documents. Any labor, documentation, services, materials, or equipment that may reasonably be inferred from the Contract Documents or from prevailing custom or trade usage as being required to produce the intended result will be provided whether or not specifically called for at no additional cost to Owner.
- C. Clarifications and interpretations of the Contract Documents shall be issued by Engineer as provided in Article 9.

#### 3.02 *Reference Standards*

##### A. *Standards, Specifications, Codes, Laws, and Regulations*

1. Reference to standards, specifications, manuals, or codes of any technical society, organization, or association, or to Laws or Regulations, whether such reference be specific or by implication, shall mean the standard, specification, manual, code, or Laws or Regulations in effect at the time of opening of Bids (or on the Effective Date of the Agreement if there were no Bids), except as may be otherwise specifically stated in the Contract Documents.
2. No provision of any such standard, specification, manual or code, or any instruction of a Supplier shall be effective to change the duties or responsibilities of Owner, Contractor, or Engineer, or any of their subcontractors, consultants, agents, or employees from those set forth in the Contract Documents. No such provision or instruction shall be effective to assign to Owner, or Engineer, or any of their Related Entities, any duty or authority to supervise or direct the performance of the Work or any duty or authority to undertake responsibility inconsistent with the provisions of the Contract Documents.

#### 3.03 *Reporting and Resolving Discrepancies*

##### A. *Reporting Discrepancies*

1. *Contractor's Review of Contract Documents Before Starting Work:* Before undertaking each part of the Work, Contractor shall carefully study and compare the Contract Documents and check and verify pertinent figures therein and all applicable field measurements. Contractor shall promptly report in writing to Engineer any conflict, error, ambiguity, or discrepancy which Contractor may discover and shall obtain a written interpretation or clarification from Engineer before proceeding with any Work affected thereby.
2. *Contractor's Review of Contract Documents During Performance of Work:* If, during the performance of the Work, Contractor discovers any conflict, error, ambiguity, or discrepancy within the Contract Documents or between the Contract Documents and any provision of any Law or Regulation applicable to the performance of the Work or of any standard, specification, manual or code, or of any instruction of any Supplier, Contractor shall promptly report it to Engineer in writing. Contractor shall not proceed with the Work affected thereby (except in an emergency as required by

Paragraph 6.16.A) until an amendment or supplement to the Contract Documents has been issued by one of the methods indicated in Paragraph 3.04.

3. Contractor shall not be liable to Owner or Engineer for failure to report any conflict, error, ambiguity, or discrepancy in the Contract Documents unless Contractor knew or reasonably should have known thereof.

B. *Resolving Discrepancies*

1. Except as may be otherwise specifically stated in the Contract Documents, the provisions of the Contract Documents shall take precedence in resolving any conflict, error, ambiguity, or discrepancy between the provisions of the Contract Documents and:
  - a. the provisions of any standard, specification, manual, code, or instruction (whether or not specifically incorporated by reference in the Contract Documents); or
  - b. the provisions of any Laws or Regulations applicable to the performance of the Work (unless such an interpretation of the provisions of the Contract Documents would result in violation of such Law or Regulation).

3.04 *Amending and Supplementing Contract Documents*

- A. The Contract Documents may be amended to provide for additions, deletions, and revisions in the Work or to modify the terms and conditions thereof by either a Change Order or a Work Change Directive.
- B. The requirements of the Contract Documents may be supplemented, and minor variations and deviations in the Work may be authorized, by one or more of the following ways:
  1. a Field Order;
  2. Engineer's approval of a Shop Drawing or Sample; (subject to the provisions of Paragraph 6.17.D.3);  
or
  3. Engineer's written interpretation or clarification.

3.05 *Reuse of Documents*

- A. Contractor and any Subcontractor or Supplier or shall not:
  1. have or acquire any title to or ownership rights in any of the Drawings, Specifications, or other documents (or copies of any thereof) prepared by or bearing the seal of Engineer or Engineer's consultants, including electronic media editions; or
  2. reuse any of such Drawings, Specifications, other documents, or copies thereof on extensions of the Project or any other project without written consent of Owner and Engineer and specific written verification or adaption by Engineer.
- B. The prohibition of this Paragraph 3.05 will survive final payment, or termination of the Contract. Nothing herein shall preclude Contractor from retaining copies of the Contract Documents for record purposes.



3.06 *Electronic Data*

- A. Copies of data furnished by Owner or Engineer to Contractor or Contractor to Owner or Engineer that may be relied upon are limited to the printed copies (also known as hard copies). Files in electronic media format of text, data, graphics, or other types are furnished only for the convenience of the receiving party. Any conclusion or information obtained or derived from such electronic files will be at the user's sole risk. If there is a discrepancy between the electronic files and the hard copies, the hard copies govern.
- B. Because data stored in electronic media format can deteriorate or be modified inadvertently or otherwise without authorization of the data's creator, the party receiving electronic files agrees that it will perform acceptance tests or procedures within 60 days, after which the receiving party shall be deemed to have accepted the data thus transferred. Any errors detected within the 60-day acceptance period will be corrected by the transferring party.
- C. When transferring documents in electronic media format, the transferring party makes no representations as to long term compatibility, usability, or readability of documents resulting from the use of software application packages, operating systems, or computer hardware differing from those used by the data's creator.

**ARTICLE 4 - AVAILABILITY OF LANDS; SUBSURFACE AND PHYSICAL CONDITIONS; HAZARDOUS ENVIRONMENTAL CONDITIONS; REFERENCE POINTS**

4.01 *Availability of Lands*

- A. Owner shall furnish the Site. Owner shall notify Contractor of any encumbrances or restrictions not of general application but specifically related to use of the Site with which Contractor must comply in performing the Work. Owner will obtain in a timely manner and pay for easements for permanent structures or permanent changes in existing facilities. If Contractor and Owner are unable to agree on entitlement to or on the amount or extent, if any, of any adjustment in the Contract Price or Contract Times, or both, as a result of any delay in Owner's furnishing the Site or a part thereof, Contractor may make a Claim therefor as provided in Paragraph 10.05.
- B. Contractor shall provide for all additional lands and access thereto that may be required for temporary construction facilities or storage of materials and equipment.

4.02 *Subsurface and Physical Conditions*

- A. *Reports and Drawings:* The Supplementary Conditions identify:
  - 1. those reports of explorations and tests of subsurface conditions at or contiguous to the Site that Engineer has used in preparing the Contract Documents; and
  - 2. those drawings of physical conditions in or relating to existing surface or subsurface structures at or contiguous to the Site (except Underground Facilities) that Engineer has used in preparing the Contract Documents.
- B. *Limited Reliance by Contractor on Technical Data Authorized:* Contractor may rely upon the general accuracy of the "technical data" contained in such reports and drawings, but such reports and drawings are not Contract Documents. Such "technical data" is identified in the Supplementary Conditions. Except for such reliance on such "technical data," Contractor may not rely upon or make any claim against Owner or Engineer, or any of their Related Entities with respect to:

1. the completeness of such reports and drawings for Contractor's purposes, including, but not limited to, any aspects of the means, methods, techniques, sequences, and procedures of construction to be employed by Contractor, and safety precautions and programs incident thereto; or
2. other data, interpretations, opinions, and information contained in such reports or shown or indicated in such drawings; or
3. any Contractor interpretation of or conclusion drawn from any "technical data" or any such other data, interpretations, opinions, or information.

4.03 *Differing Subsurface or Physical Conditions*

- A. *Notice:* If Contractor believes that any subsurface or physical condition at or contiguous to the Site that is uncovered or revealed either:
1. is of such a nature as to establish that any "technical data" on which Contractor is entitled to rely as provided in Paragraph 4.02 is materially inaccurate; or
  2. is of such a nature as to require a change in the Contract Documents; or
  3. differs materially from that shown or indicated in the Contract Documents; or
  4. is of an unusual nature, and differs materially from conditions ordinarily encountered and generally recognized as inherent in work of the character provided for in the Contract Documents;

then Contractor shall, promptly after becoming aware thereof and before further disturbing the subsurface or physical conditions or performing any Work in connection therewith (except in an emergency as required by Paragraph 6.16.A), notify Owner and Engineer in writing about such condition. Contractor shall not further disturb such condition or perform any Work in connection therewith (except as aforesaid) until receipt of written order to do so.

- B. *Engineer's Review:* After receipt of written notice as required by Paragraph 4.03.A, Engineer will promptly review the pertinent condition, determine the necessity of Owner's obtaining additional exploration or tests with respect thereto, and advise Owner in writing (with a copy to Contractor) of Engineer's findings and conclusions.

C. *Possible Price and Times Adjustments*

1. The Contract Price or the Contract Times, or both, will be equitably adjusted to the extent that the existence of such differing subsurface or physical condition causes an increase or decrease in Contractor's cost of, or time required for, performance of the Work; subject, however, to the following:
  - a. such condition must meet any one or more of the categories described in Paragraph 4.03.A; and
  - b. with respect to Work that is paid for on a Unit Price Basis, any adjustment in Contract Price will be subject to the provisions of Paragraphs 9.07 and 11.03.
2. Contractor shall not be entitled to any adjustment in the Contract Price or Contract Times if:
  - a. Contractor knew of the existence of such conditions at the time Contractor made a final commitment to Owner with respect to Contract Price and Contract Times by the submission of a Bid or becoming bound under a negotiated contract; or

- b. the existence of such condition could reasonably have been discovered or revealed as a result of any examination, investigation, exploration, test, or study of the Site and contiguous areas required by the Bidding Requirements or Contract Documents to be conducted by or for Contractor prior to Contractor's making such final commitment; or
  - c. Contractor failed to give the written notice as required by Paragraph 4.03.A.
3. If Owner and Contractor are unable to agree on entitlement to or on the amount or extent, if any, of any adjustment in the Contract Price or Contract Times, or both, a Claim may be made therefor as provided in Paragraph 10.05. However, Owner and Engineer, and any of their Related Entities shall not be liable to Contractor for any claims, costs, losses, or damages (including but not limited to all fees and charges of engineers, architects, attorneys, and other professionals and all court or arbitration or other dispute resolution costs) sustained by Contractor on or in connection with any other project or anticipated project.

#### 4.04 *Underground Facilities*

- A. *Shown or Indicated:* The information and data shown or indicated in the Contract Documents with respect to existing Underground Facilities at or contiguous to the Site is based on information and data furnished to Owner or Engineer by the owners of such Underground Facilities, including Owner, or by others. Unless it is otherwise expressly provided in the Supplementary Conditions:
- 1. Owner and Engineer shall not be responsible for the accuracy or completeness of any such information or data; and
  - 2. the cost of all of the following will be included in the Contract Price, and Contractor shall have full responsibility for:
    - a. reviewing and checking all such information and data,
    - b. locating all Underground Facilities shown or indicated in the Contract Documents,
    - c. coordination of the Work with the owners of such Underground Facilities, including Owner, during construction, and
    - d. the safety and protection of all such Underground Facilities and repairing any damage thereto resulting from the Work.
- B. *Not Shown or Indicated*
- 1. If an Underground Facility is uncovered or revealed at or contiguous to the Site which was not shown or indicated, or not shown or indicated with reasonable accuracy in the Contract Documents, Contractor shall, promptly after becoming aware thereof and before further disturbing conditions affected thereby or performing any Work in connection therewith (except in an emergency as required by Paragraph 6.16.A), identify the owner of such Underground Facility and give written notice to that owner and to Owner and Engineer. Engineer will promptly review the Underground Facility and determine the extent, if any, to which a change is required in the Contract Documents to reflect and document the consequences of the existence or location of the Underground Facility. During such time, Contractor shall be responsible for the safety and protection of such Underground Facility.
  - 2. If Engineer concludes that a change in the Contract Documents is required, a Work Change Directive or a Change Order will be issued to reflect and document such consequences. An equitable adjustment shall be made in the Contract Price or Contract Times, or both, to the extent that they are attributable to the existence or location of any Underground Facility that was not shown or indicated

or not shown or indicated with reasonable accuracy in the Contract Documents and that Contractor did not know of and could not reasonably have been expected to be aware of or to have anticipated. If Owner and Contractor are unable to agree on entitlement to or on the amount or extent, if any, of any such adjustment in Contract Price or Contract Times, Owner or Contractor may make a Claim therefor as provided in Paragraph 10.05.

4.05 *Reference Points*

- A. Owner shall provide engineering surveys to establish reference points for construction which in Engineer's judgment are necessary to enable Contractor to proceed with the Work. Contractor shall be responsible for laying out the Work, shall protect and preserve the established reference points and property monuments, and shall make no changes or relocations without the prior written approval of Owner. Contractor shall report to Engineer whenever any reference point or property monument is lost or destroyed or requires relocation because of necessary changes in grades or locations, and shall be responsible for the accurate replacement or relocation of such reference points or property monuments by professionally qualified personnel.

4.06 *Hazardous Environmental Condition at Site*

- A. *Reports and Drawings:* Reference is made to the Supplementary Conditions for the identification of those reports and drawings relating to a Hazardous Environmental Condition identified at the Site, if any, that have been utilized by the Engineer in the preparation of the Contract Documents.
- B. *Limited Reliance by Contractor on Technical Data Authorized:* Contractor may rely upon the general accuracy of the "technical data" contained in such reports and drawings, but such reports and drawings are not Contract Documents. Such "technical data" is identified in the Supplementary Conditions. Except for such reliance on such "technical data," Contractor may not rely upon or make any claim against Owner or Engineer, or any of their Related Entities with respect to:
  - 1. the completeness of such reports and drawings for Contractor's purposes, including, but not limited to, any aspects of the means, methods, techniques, sequences and procedures of construction to be employed by Contractor and safety precautions and programs incident thereto; or
  - 2. other data, interpretations, opinions and information contained in such reports or shown or indicated in such drawings; or
  - 3. any Contractor interpretation of or conclusion drawn from any "technical data" or any such other data, interpretations, opinions or information.
- C. Contractor shall not be responsible for any Hazardous Environmental Condition uncovered or revealed at the Site which was not shown or indicated in Drawings or Specifications or identified in the Contract Documents to be within the scope of the Work. Contractor shall be responsible for a Hazardous Environmental Condition created with any materials brought to the Site by Contractor, Subcontractors, Suppliers, or anyone else for whom Contractor is responsible.
- D. If Contractor encounters a Hazardous Environmental Condition or if Contractor or anyone for whom Contractor is responsible creates a Hazardous Environmental Condition, Contractor shall immediately: (i) secure or otherwise isolate such condition; (ii) stop all Work in connection with such condition and in any area affected thereby (except in an emergency as required by Paragraph 6.16.A); and (iii) notify Owner and Engineer (and promptly thereafter confirm such notice in writing). Owner shall promptly consult with Engineer concerning the necessity for Owner to retain a qualified expert to evaluate such condition or take corrective action, if any.
- E. Contractor shall not be required to resume Work in connection with such condition or in any affected area until after Owner has obtained any required permits related thereto and delivered to Contractor written

notice: (i) specifying that such condition and any affected area is or has been rendered safe for the resumption of Work; or (ii) specifying any special conditions under which such Work may be resumed safely. If Owner and Contractor cannot agree as to entitlement to or on the amount or extent, if any, of any adjustment in Contract Price or Contract Times, or both, as a result of such Work stoppage or such special conditions under which Work is agreed to be resumed by Contractor, either party may make a Claim therefor as provided in Paragraph 10.05.

- F. If after receipt of such written notice Contractor does not agree to resume such Work based on a reasonable belief it is unsafe, or does not agree to resume such Work under such special conditions, then Owner may order the portion of the Work that is in the area affected by such condition to be deleted from the Work. If Owner and Contractor cannot agree as to entitlement to or on the amount or extent, if any, of an adjustment in Contract Price or Contract Times as a result of deleting such portion of the Work, then either party may make a Claim therefor as provided in Paragraph 10.05. Owner may have such deleted portion of the Work performed by Owner's own forces or others in accordance with Article 7.
- G. To the fullest extent permitted by Laws and Regulations, Contractor shall indemnify and hold harmless Owner and Engineer, and the officers, directors, partners, employees, agents, consultants, and subcontractors of each and any of them from and against all claims, costs, losses, and damages (including but not limited to all fees and charges of engineers, architects, attorneys, and other professionals and all court or arbitration or other dispute resolution costs) arising out of or relating to a Hazardous Environmental Condition created by Contractor or by anyone for whom Contractor is responsible. Nothing in this Paragraph 4.06.G shall obligate Contractor to indemnify any individual or entity from and against the consequences of that individual's or entity's own negligence.
- H. The provisions of Paragraphs 4.02, 4.03, and 4.04 do not apply to a Hazardous Environmental Condition uncovered or revealed at the Site.

## **ARTICLE 5 - BONDS AND INSURANCE**

### *5.01 Performance, Payment, and Other Bonds*

- A. Contractor shall furnish performance and payment bonds, each in an amount at least equal to the Contract Price as security for the faithful performance and payment of all of Contractor's obligations under the Contract Documents. These bonds shall remain in effect until one year after the date when final payment becomes due or until completion of the correction period specified in Paragraph 13.07, whichever is later, except as provided otherwise by Laws or Regulations or by the Contract Documents. Contractor shall also furnish such other bonds as are required by the Contract Documents.
- B. All bonds shall be in the form prescribed by the Contract Documents except as provided otherwise by Laws or Regulations, and shall be executed by such sureties as are named in the current list of "Companies Holding Certificates of Authority as Acceptable Sureties on Federal Bonds and as Acceptable Reinsuring Companies" as published in Circular 570 (amended) by the Financial Management Service, Surety Bond Branch, U.S. Department of the Treasury. All bonds signed by an agent must be accompanied by a certified copy of the agent's authority to act.
- C. If the surety on any bond furnished by Contractor is declared bankrupt or becomes insolvent or its right to do business is terminated in any state where any part of the Project is located or it ceases to meet the requirements of Paragraph 5.01.B, Contractor shall promptly notify Owner and Engineer and shall, within 20 days after the event giving rise to such notification, provide another bond and surety, both of which shall comply with the requirements of Paragraphs 5.01.B and 5.02.

5.02 *Licensed Sureties and Insurers*

- A. All bonds and insurance required by the Contract Documents to be purchased and maintained by Owner or Contractor shall be obtained from surety or insurance companies that are duly licensed or authorized in the jurisdiction in which the Project is located to issue bonds or insurance policies for the limits and coverages so required. Such surety and insurance companies shall also meet such additional requirements and qualifications as may be provided in the Supplementary Conditions.

5.03 *Certificates of Insurance*

- A. Contractor shall deliver to Owner, with copies to each additional insured identified in the Supplementary Conditions, certificates of insurance (and other evidence of insurance requested by Owner or any other additional insured) which Contractor is required to purchase and maintain.
- B. Owner shall deliver to Contractor, with copies to each additional insured identified in the Supplementary Conditions, certificates of insurance (and other evidence of insurance requested by Contractor or any other additional insured) which Owner is required to purchase and maintain.

5.04 *Contractor's Liability Insurance*

- A. Contractor shall purchase and maintain such liability and other insurance as is appropriate for the Work being performed and as will provide protection from claims set forth below which may arise out of or result from Contractor's performance of the Work and Contractor's other obligations under the Contract Documents, whether it is to be performed by Contractor, any Subcontractor or Supplier, or by anyone directly or indirectly employed by any of them to perform any of the Work, or by anyone for whose acts any of them may be liable:
  - 1. claims under workers' compensation, disability benefits, and other similar employee benefit acts;
  - 2. claims for damages because of bodily injury, occupational sickness or disease, or death of Contractor's employees;
  - 3. claims for damages because of bodily injury, sickness or disease, or death of any person other than Contractor's employees;
  - 4. claims for damages insured by reasonably available personal injury liability coverage which are sustained:
    - a. by any person as a result of an offense directly or indirectly related to the employment of such person by Contractor, or
    - b. by any other person for any other reason;
  - 5. claims for damages, other than to the Work itself, because of injury to or destruction of tangible property wherever located, including loss of use resulting therefrom; and
  - 6. claims for damages because of bodily injury or death of any person or property damage arising out of the ownership, maintenance or use of any motor vehicle.
- B. The policies of insurance required by this Paragraph 5.04 shall:
  - 1. with respect to insurance required by Paragraphs 5.04.A.3 through 5.04.A.6 inclusive, include as additional insureds (subject to any customary exclusion regarding professional liability) Owner and Engineer, and any other individuals or entities identified in the Supplementary Conditions, all of whom shall be listed as additional insureds, and include coverage for the respective officers,

directors, partners, employees, agents, consultants and subcontractors of each and any of all such additional insureds, and the insurance afforded to these additional insureds shall provide primary coverage for all claims covered thereby;

2. include at least the specific coverages and be written for not less than the limits of liability provided in the Supplementary Conditions or required by Laws or Regulations, whichever is greater;
3. include completed operations insurance;
4. include contractual liability insurance covering Contractor's indemnity obligations under Paragraphs 6.11 and 6.20;
5. contain a provision or endorsement that the coverage afforded will not be canceled, materially changed or renewal refused until at least 30 days prior written notice has been given to Owner and Contractor and to each other additional insured identified in the Supplementary Conditions to whom a certificate of insurance has been issued (and the certificates of insurance furnished by the Contractor pursuant to Paragraph 5.03 will so provide);
6. remain in effect at least until final payment and at all times thereafter when Contractor may be correcting, removing, or replacing defective Work in accordance with Paragraph 13.07; and
7. with respect to completed operations insurance, and any insurance coverage written on a claims-made basis, remain in effect for at least two years after final payment.
  - a. Contractor shall furnish Owner and each other additional insured identified in the Supplementary Conditions, to whom a certificate of insurance has been issued, evidence satisfactory to Owner and any such additional insured of continuation of such insurance at final payment and one year thereafter.

5.05 *Owner's Liability Insurance*

- A. In addition to the insurance required to be provided by Contractor under Paragraph 5.04, Owner, at Owner's option, may purchase and maintain at Owner's expense Owner's own liability insurance as will protect Owner against claims which may arise from operations under the Contract Documents.

5.06 (Not Used)

5.07 (Not Used)

5.08 (Not Used)

5.09 (Not Used)

5.10 *Acceptance of Bonds and Insurance; Option to Replace*

- A. If either Owner or Contractor has any objection to the coverage afforded by or other provisions of the bonds or insurance required to be purchased and maintained by the other party in accordance with Article 5 on the basis of non-conformance with the Contract Documents, the objecting party shall so notify the other party in writing within 10 days after receipt of the certificates (or other evidence requested) required by Paragraph 2.01.B. Contractor shall provide such additional information in respect of insurance provided. If Contractor does not purchase or maintain all of the bonds and insurance required of such party by the Contract Documents, Contractor shall notify the Owner in writing of such failure to purchase prior to the start of the Work, or of such failure to maintain prior to any change in the required coverage. Without prejudice to any other right or remedy, the other party may elect to obtain equivalent bonds or insurance to

protect such other party's interests at the expense of the party who was required to provide such coverage, and a Change Order shall be issued to adjust the Contract Price accordingly.

## **ARTICLE 6 - CONTRACTOR'S RESPONSIBILITIES**

### *6.01 Supervision and Superintendence*

- A. Contractor shall supervise, inspect, and direct the Work competently and efficiently, devoting such attention thereto and applying such skills and expertise as may be necessary to perform the Work in accordance with the Contract Documents. Contractor shall be solely responsible for the means, methods, techniques, sequences, and procedures of construction. Contractor shall not be responsible for the negligence of Owner or Engineer in the design or specification of a specific means, method, technique, sequence, or procedure of construction which is shown or indicated in and expressly required by the Contract Documents.
- B. At all times during the progress of the Work, Contractor shall assign a competent resident superintendent who shall not be replaced without written notice to Owner and Engineer except under extraordinary circumstances. The superintendent will be Contractor's representative at the Site and shall have authority to act on behalf of Contractor. All communications given to or received from the superintendent shall be binding on Contractor.

### *6.02 Labor; Working Hours*

- A. Contractor shall provide competent, suitably qualified personnel to survey and lay out the Work and perform construction as required by the Contract Documents. Contractor shall at all times maintain good discipline and order at the Site.
- B. Except as otherwise required for the safety or protection of persons or the Work or property at the Site or adjacent thereto, and except as otherwise stated in the Contract Documents, all Work at the Site shall be performed during regular working hours. Contractor will not permit the performance of Work on a Saturday, Sunday, or any legal holiday without Owner's written consent (which will not be unreasonably withheld) given after prior written notice to Engineer.

### *6.03 Services, Materials, and Equipment*

- A. Unless otherwise specified in the Contract Documents, Contractor shall provide and assume full responsibility for all services, materials, equipment, labor, transportation, construction equipment and machinery, tools, appliances, fuel, power, light, heat, telephone, water, sanitary facilities, temporary facilities, and all other facilities and incidentals necessary for the performance, testing, start-up, and completion of the Work.
- B. All materials and equipment incorporated into the Work shall be as specified or, if not specified, shall be of good quality and new, except as otherwise provided in the Contract Documents. All special warranties and guarantees required by the Specifications shall expressly run to the benefit of Owner. If required by Engineer, Contractor shall furnish satisfactory evidence (including reports of required tests) as to the source, kind, and quality of materials and equipment.
- C. All materials and equipment shall be stored, applied, installed, connected, erected, protected, used, cleaned, and conditioned in accordance with instructions of the applicable Supplier, except as otherwise may be provided in the Contract Documents.



6.04 *Progress Schedule*

- A. Contractor shall adhere to the Progress Schedule established in accordance with Paragraph 2.07 as it may be adjusted from time to time as provided below.
  - 1. Contractor shall submit to Engineer for acceptance (to the extent indicated in Paragraph 2.07) proposed adjustments in the Progress Schedule that will not result in changing the Contract Times. Such adjustments will comply with any provisions of the General Requirements applicable thereto.
  - 2. Proposed adjustments in the Progress Schedule that will change the Contract Times shall be submitted in accordance with the requirements of Article 12. Adjustments in Contract Times may only be made by a Change Order.

6.05 *Substitutes and "Or-Equals"*

- A. Whenever an item of material or equipment is specified or described in the Contract Documents by using the name of a proprietary item or the name of a particular Supplier, the specification or description is intended to establish the type, function, appearance, and quality required. Unless the specification or description contains or is followed by words reading that no like, equivalent, or "or-equal" item or no substitution is permitted, other items of material or equipment or material or equipment of other Suppliers may be submitted to Engineer for review under the circumstances described below.
  - 1. "*Or-Equal*" Items: If in Engineer's sole discretion an item of material or equipment proposed by Contractor is functionally equal to that named and sufficiently similar so that no change in related Work will be required, it may be considered by Engineer as an "or-equal" item, in which case review and approval of the proposed item may, in Engineer's sole discretion, be accomplished without compliance with some or all of the requirements for approval of proposed substitute items. For the purposes of this Paragraph 6.05.A.1, a proposed item of material or equipment will be considered functionally equal to an item so named if:
    - a. in the exercise of reasonable judgment Engineer determines that:
      - 1) it is at least equal in materials of construction, quality, durability, appearance, strength, and design characteristics,
      - 2) it will reliably perform at least equally well the function and achieve the results imposed by the design concept of the completed Project as a functioning whole,
      - 3) it has a proven record of performance and availability of responsive service; and
    - b. Contractor certifies that, if approved and incorporated into the Work:
      - 1) there will be no increase in cost to the Owner or increase in Contract Times, and
      - 2) it will conform substantially to the detailed requirements of the item named in the Contract Documents.
  - 2. *Substitute Items*
    - a. If in Engineer's sole discretion an item of material or equipment proposed by Contractor does not qualify as an "or-equal" item under Paragraph 6.05.A.1, it will be considered a proposed substitute item.
    - b. Contractor shall submit sufficient information as provided below to allow Engineer to determine that the item of material or equipment proposed is essentially equivalent to that named and an

acceptable substitute therefor. Requests for review of proposed substitute items of material or equipment will not be accepted by Engineer from anyone other than Contractor.

- c. The requirements for review by Engineer will be as set forth in Paragraph 6.05.A.2.d, as supplemented in the General Requirements and as Engineer may decide is appropriate under the circumstances.
  - d. Contractor shall make written application to Engineer for review of a proposed substitute item of material or equipment that Contractor seeks to furnish or use. The application:
    - 1) shall certify that the proposed substitute item will:
      - a) perform adequately the functions and achieve the results called for by the general design,
      - b) be similar in substance to that specified, and
      - c) be suited to the same use as that specified;
    - 2) will state:
      - a) the extent, if any, to which the use of the proposed substitute item will prejudice Contractor's achievement of Substantial Completion on time;
      - b) whether or not use of the proposed substitute item in the Work will require a change in any of the Contract Documents (or in the provisions of any other direct contract with Owner for other work on the Project) to adapt the design to the proposed substitute item; and
      - c) whether or not incorporation or use of the proposed substitute item in connection with the Work is subject to payment of any license fee or royalty;
    - 3) will identify:
      - a) all variations of the proposed substitute item from that specified, and
      - b) available engineering, sales, maintenance, repair, and replacement services,
    - 4) and shall contain an itemized estimate of all costs or credits that will result directly or indirectly from use of such substitute item, including costs of redesign and claims of other contractors affected by any resulting change.
- B. *Substitute Construction Methods or Procedures:* If a specific means, method, technique, sequence, or procedure of construction is expressly required by the Contract Documents, Contractor may furnish or utilize a substitute means, method, technique, sequence, or procedure of construction approved by Engineer. Contractor shall submit sufficient information to allow Engineer, in Engineer's sole discretion, to determine that the substitute proposed is equivalent to that expressly called for by the Contract Documents. The requirements for review by Engineer will be similar to those provided in Paragraph 6.05.A.2.
- C. *Engineer's Evaluation:* Engineer will be allowed a reasonable time within which to evaluate each proposal or submittal made pursuant to Paragraphs 6.05.A and 6.05.B. Engineer may require Contractor to furnish additional data about the proposed substitute item. Engineer will be the sole judge of acceptability. No "or equal" or substitute will be ordered, installed or utilized until Engineer's review is complete, which will be evidenced by either a Change Order for a substitute or an approved Shop Drawing for an "or equal." Engineer will advise Contractor in writing of any negative determination.

- D. *Special Guarantee:* Owner may require Contractor to furnish at Contractor's expense a special performance guarantee or other surety with respect to any substitute.
- E. *Engineer's Cost Reimbursement:* Engineer will record Engineer's costs in evaluating a substitute proposed or submitted by Contractor pursuant to Paragraphs 6.05.A.2 and 6.05.B. Whether or not Engineer approves a substitute item so proposed or submitted by Contractor, Contractor shall reimburse Owner for the charges of Engineer for evaluating each such proposed substitute. Contractor shall also reimburse Owner for the charges of Engineer for making changes in the Contract Documents (or in the provisions of any other direct contract with Owner) resulting from the acceptance of each proposed substitute.
- F. *Contractor's Expense:* Contractor shall provide all data in support of any proposed substitute or "or-equal" at Contractor's expense.

6.06 *Concerning Subcontractors, Suppliers, and Others*

- A. Contractor shall not employ any Subcontractor, Supplier, or other individual or entity (including those acceptable to Owner as indicated in Paragraph 6.06.B), whether initially or as a replacement, against whom Owner may have reasonable objection. Contractor shall not be required to employ any Subcontractor, Supplier, or other individual or entity to furnish or perform any of the Work against whom Contractor has reasonable objection.
- B. If the Supplementary Conditions require the identity of certain Subcontractors, Suppliers, or other individuals or entities to be submitted to Owner in advance for acceptance by Owner by a specified date prior to the Effective Date of the Agreement, and if Contractor has submitted a list thereof in accordance with the Supplementary Conditions, Owner's acceptance (either in writing or by failing to make written objection thereto by the date indicated for acceptance or objection in the Bidding Documents or the Contract Documents) of any such Subcontractor, Supplier, or other individual or entity so identified may be revoked on the basis of reasonable objection after due investigation. Contractor shall submit an acceptable replacement for the rejected Subcontractor, Supplier, or other individual or entity, and the Contract Price will be adjusted by the difference in the cost occasioned by such replacement, and an appropriate Change Order will be issued. No acceptance by Owner of any such Subcontractor, Supplier, or other individual or entity, whether initially or as a replacement, shall constitute a waiver of any right of Owner or Engineer to reject defective Work.
- C. Contractor shall be fully responsible to Owner and Engineer for all acts and omissions of the Subcontractors, Suppliers, and other individuals or entities performing or furnishing any of the Work just as Contractor is responsible for Contractor's own acts and omissions. Nothing in the Contract Documents:
  - 1. shall create for the benefit of any such Subcontractor, Supplier, or other individual or entity any contractual relationship between Owner or Engineer and any such Subcontractor, Supplier or other individual or entity; nor
  - 2. shall anything in the Contract Documents create any obligation on the part of Owner or Engineer to pay or to see to the payment of any moneys due any such Subcontractor, Supplier, or other individual or entity except as may otherwise be required by Laws and Regulations.
- D. Contractor shall be solely responsible for scheduling and coordinating the Work of Subcontractors, Suppliers, and other individuals or entities performing or furnishing any of the Work under a direct or indirect contract with Contractor.
- E. Contractor shall require all Subcontractors, Suppliers, and such other individuals or entities performing or furnishing any of the Work to communicate with Engineer through Contractor.

- F. The divisions and sections of the Specifications and the identifications of any Drawings shall not control Contractor in dividing the Work among Subcontractors or Suppliers or delineating the Work to be performed by any specific trade.
- G. All Work performed for Contractor by a Subcontractor or Supplier will be pursuant to an appropriate agreement between Contractor and the Subcontractor or Supplier which specifically binds the Subcontractor or Supplier to the applicable terms and conditions of the Contract Documents for the benefit of Owner and Engineer. Whenever any such agreement is with a Subcontractor or Supplier who is listed as an additional insured on the property insurance provided in Paragraph 5.06, the agreement between the Contractor and the Subcontractor or Supplier will contain provisions whereby the Subcontractor or Supplier waives all rights against Owner, Contractor, and Engineer, and all other individuals or entities identified in the Supplementary Conditions to be listed as insureds or additional insureds (and the officers, directors, partners, employees, agents, consultants and subcontractors of each and any of them) for all losses and damages caused by, arising out of, relating to, or resulting from any of the perils or causes of loss covered by such policies and any other property insurance applicable to the Work. If the insurers on any such policies require separate waiver forms to be signed by any Subcontractor or Supplier, Contractor will obtain the same.

6.07 *Patent Fees and Royalties*

- A. Contractor shall pay all license fees and royalties and assume all costs incident to the use in the performance of the Work or the incorporation in the Work of any invention, design, process, product, or device which is the subject of patent rights or copyrights held by others. If a particular invention, design, process, product, or device is specified in the Contract Documents for use in the performance of the Work and if to the actual knowledge of Owner or Engineer its use is subject to patent rights or copyrights calling for the payment of any license fee or royalty to others, the existence of such rights shall be disclosed by Owner in the Contract Documents.
- B. To the fullest extent permitted by Laws and Regulations, Contractor shall indemnify and hold harmless Owner and Engineer, and the officers, directors, partners, employees, agents, consultants and subcontractors of each and any of them from and against all claims, costs, losses, and damages (including but not limited to all fees and charges of engineers, architects, attorneys, and other professionals and all court or arbitration or other dispute resolution costs) arising out of or relating to any infringement of patent rights or copyrights incident to the use in the performance of the Work or resulting from the incorporation in the Work of any invention, design, process, product, or device not specified in the Contract Documents.

6.08 *Permits*

- A. Unless otherwise provided in the Supplementary Conditions, Contractor shall obtain and pay for all construction permits and licenses. Owner shall assist Contractor, when necessary, in obtaining such permits and licenses. Contractor shall pay all governmental charges and inspection fees necessary for the prosecution of the Work which are applicable at the time of opening of Bids, or, if there are no Bids, on the Effective Date of the Agreement. Owner shall pay all charges of utility owners for connections for providing permanent service to the Work.

6.09 *Laws and Regulations*

- A. Contractor shall give all notices required by and shall comply with all Laws and Regulations applicable to the performance of the Work. Except where otherwise expressly required by applicable Laws and Regulations, neither Owner nor Engineer shall be responsible for monitoring Contractor's compliance with any Laws or Regulations.
- B. If Contractor performs any Work knowing or having reason to know that it is contrary to Laws or Regulations, Contractor shall bear all claims, costs, losses, and damages (including but not limited to all fees and charges of engineers, architects, attorneys, and other professionals and all court or arbitration or

other dispute resolution costs) arising out of or relating to such Work. However, it shall not be Contractor's primary responsibility to make certain that the Specifications and Drawings are in accordance with Laws and Regulations, but this shall not relieve Contractor of Contractor's obligations under Paragraph 3.03.

- C. Changes in Laws or Regulations not known at the time of opening of Bids (or, on the Effective Date of the Agreement if there were no Bids) having an effect on the cost or time of performance of the Work shall be the subject of an adjustment in Contract Price or Contract Times. If Owner and Contractor are unable to agree on entitlement to or on the amount or extent, if any, of any such adjustment, a Claim may be made therefor as provided in Paragraph 10.05.

6.10 *Taxes*

- A. Contractor shall pay all sales, consumer, use, and other similar taxes required to be paid by Contractor in accordance with the Laws and Regulations of the place of the Project which are applicable during the performance of the Work.

6.11 *Use of Site and Other Areas*

A. *Limitation on Use of Site and Other Areas*

1. Contractor shall confine construction equipment, the storage of materials and equipment, and the operations of workers to the Site and other areas permitted by Laws and Regulations, and shall not unreasonably encumber the Site and other areas with construction equipment or other materials or equipment. Contractor shall assume full responsibility for any damage to any such land or area, or to the owner or occupant thereof, or of any adjacent land or areas resulting from the performance of the Work.
2. Should any claim be made by any such owner or occupant because of the performance of the Work, Contractor shall promptly settle with such other party by negotiation or otherwise resolve the claim by arbitration or other dispute resolution proceeding or at law.
3. To the fullest extent permitted by Laws and Regulations, Contractor shall indemnify and hold harmless Owner and Engineer, and the officers, directors, partners, employees, agents, consultants and subcontractors of each and any of them from and against all claims, costs, losses, and damages (including but not limited to all fees and charges of engineers, architects, attorneys, and other professionals and all court or arbitration or other dispute resolution costs) arising out of or relating to any claim or action, legal or equitable, brought by any such owner or occupant against Owner, Engineer, or any other party indemnified hereunder to the extent caused by or based upon Contractor's performance of the Work.

- B. *Removal of Debris During Performance of the Work:* During the progress of the Work Contractor shall keep the Site and other areas free from accumulations of waste materials, rubbish, and other debris. Removal and disposal of such waste materials, rubbish, and other debris shall conform to applicable Laws and Regulations.

- C. *Cleaning:* Prior to Substantial Completion of the Work, Contractor shall clean the Site and the Work and make it ready for utilization by Owner. At the completion of the Work Contractor shall remove from the Site all tools, appliances, construction equipment and machinery, and surplus materials and shall restore to original condition all property not designated for alteration by the Contract Documents.

- D. *Loading Structures:* Contractor shall not load nor permit any part of any structure to be loaded in any manner that will endanger the structure, nor shall Contractor subject any part of the Work or adjacent property to stresses or pressures that will endanger it.

6.12 *Record Documents*

- A. Contractor shall maintain in a safe place at the Site one record copy of all Drawings, Specifications, Addenda, Change Orders, Work Change Directives, Field Orders, and written interpretations and clarifications in good order and annotated to show changes made during construction. These record documents together with all approved Samples and a counterpart of all approved Shop Drawings will be available to Engineer for reference. Upon completion of the Work, these record documents, Samples, and Shop Drawings will be delivered to Engineer for Owner.

6.13 *Safety and Protection*

- A. Contractor shall be solely responsible for initiating, maintaining and supervising all safety precautions and programs in connection with the Work. Contractor shall take all necessary precautions for the safety of, and shall provide the necessary protection to prevent damage, injury or loss to:
  - 1. all persons on the Site or who may be affected by the Work;
  - 2. all the Work and materials and equipment to be incorporated therein, whether in storage on or off the Site; and
  - 3. other property at the Site or adjacent thereto, including trees, shrubs, lawns, walks, pavements, roadways, structures, utilities, and Underground Facilities not designated for removal, relocation, or replacement in the course of construction.
- B. Contractor shall comply with all applicable Laws and Regulations relating to the safety of persons or property, or to the protection of persons or property from damage, injury, or loss; and shall erect and maintain all necessary safeguards for such safety and protection. Contractor shall notify owners of adjacent property and of Underground Facilities and other utility owners when prosecution of the Work may affect them, and shall cooperate with them in the protection, removal, relocation, and replacement of their property.
- C. All damage, injury, or loss to any property referred to in Paragraph 6.13.A.2 or 6.13.A.3 caused, directly or indirectly, in whole or in part, by Contractor, any Subcontractor, Supplier, or any other individual or entity directly or indirectly employed by any of them to perform any of the Work, or anyone for whose acts any of them may be liable, shall be remedied by Contractor (except damage or loss attributable to the fault of Drawings or Specifications or to the acts or omissions of Owner or Engineer or, or anyone employed by any of them, or anyone for whose acts any of them may be liable, and not attributable, directly or indirectly, in whole or in part, to the fault or negligence of Contractor or any Subcontractor, Supplier, or other individual or entity directly or indirectly employed by any of them).
- D. Contractor's duties and responsibilities for safety and for protection of the Work shall continue until such time as all the Work is completed and Engineer has issued a notice to Owner and Contractor in accordance with Paragraph 14.07.B that the Work is acceptable (except as otherwise expressly provided in connection with Substantial Completion).

6.14 *Safety Representative*

- A. Contractor shall designate a qualified and experienced safety representative at the Site whose duties and responsibilities shall be the prevention of accidents and the maintaining and supervising of safety precautions and programs.

6.15 *Hazard Communication Programs*

- A. Contractor shall be responsible for coordinating any exchange of material safety data sheets or other hazard communication information required to be made available to or exchanged between or among employers at the Site in accordance with Laws or Regulations.

6.16 *Emergencies*

- A. In emergencies affecting the safety or protection of persons or the Work or property at the Site or adjacent thereto, Contractor is obligated to act to prevent threatened damage, injury, or loss. Contractor shall give Engineer prompt written notice if Contractor believes that any significant changes in the Work or variations from the Contract Documents have been caused thereby or are required as a result thereof. If Engineer determines that a change in the Contract Documents is required because of the action taken by Contractor in response to such an emergency, a Work Change Directive or Change Order will be issued.

6.17 *Shop Drawings and Samples*

- A. Contractor shall submit Shop Drawings and Samples to Engineer for review and approval in accordance with the acceptable Schedule of Submittals (as required by Paragraph 2.07). Each submittal will be identified as Engineer may require.

- 1. *Shop Drawings*

- a. Submit number of copies specified in the General Requirements.
- b. Data shown on the Shop Drawings will be complete with respect to quantities, dimensions, specified performance and design criteria, materials, and similar data to show Engineer the services, materials, and equipment Contractor proposes to provide and to enable Engineer to review the information for the limited purposes required by Paragraph 6.17.D.

- 2. *Samples*

- a. Submit number of Samples specified in the Specifications.
- b. Clearly identify each Sample as to material, Supplier, pertinent data such as catalog numbers, the use for which intended and other data as Engineer may require to enable Engineer to review the submittal for the limited purposes required by Paragraph 6.17.D.

- B. Where a Shop Drawing or Sample is required by the Contract Documents or the Schedule of Submittals, any related Work performed prior to Engineer's review and approval of the pertinent submittal will be at the sole expense and responsibility of Contractor.

- C. *Submittal Procedures*

- 1. Before submitting each Shop Drawing or Sample, Contractor shall have determined and verified:
  - a. all field measurements, quantities, dimensions, specified performance and design criteria, installation requirements, materials, catalog numbers, and similar information with respect thereto;
  - b. the suitability of all materials with respect to intended use, fabrication, shipping, handling, storage, assembly, and installation pertaining to the performance of the Work;

- c. all information relative to Contractor's responsibilities for means, methods, techniques, sequences, and procedures of construction, and safety precautions and programs incident thereto; and
  - d. shall also have reviewed and coordinated each Shop Drawing or Sample with other Shop Drawings and Samples and with the requirements of the Work and the Contract Documents.
2. Each submittal shall bear a stamp or specific written certification that Contractor has satisfied Contractor's obligations under the Contract Documents with respect to Contractor's review and approval of that submittal.
  3. With each submittal, Contractor shall give Engineer specific written notice of any variations, that the Shop Drawing or Sample may have from the requirements of the Contract Documents. This notice shall be both a written communication separate from the Shop Drawing or Sample submittal; and, in addition, by a specific notation made on each Shop Drawing or Sample submitted to Engineer for review and approval of each such variation.

D. *Engineer's Review*

1. Engineer will provide timely review of Shop Drawings and Samples in accordance with the Schedule of Submittals acceptable to Engineer. Engineer's review and approval will be only to determine if the items covered by the submittals will, after installation or incorporation in the Work, conform to the information given in the Contract Documents and be compatible with the design concept of the completed Project as a functioning whole as indicated by the Contract Documents.
2. Engineer's review and approval will not extend to means, methods, techniques, sequences, or procedures of construction (except where a particular means, method, technique, sequence, or procedure of construction is specifically and expressly called for by the Contract Documents) or to safety precautions or programs incident thereto. The review and approval of a separate item as such will not indicate approval of the assembly in which the item functions.
3. Engineer's review and approval shall not relieve Contractor from responsibility for any variation from the requirements of the Contract Documents unless Contractor has complied with the requirements of Paragraph 6.17.C.3 and Engineer has given written approval of each such variation by specific written notation thereof incorporated in or accompanying the Shop Drawing or Sample. Engineer's review and approval shall not relieve Contractor from responsibility for complying with the requirements of Paragraph 6.17.C.1.

E. *Resubmittal Procedures*

1. Contractor shall make corrections required by Engineer and shall return the required number of corrected copies of Shop Drawings and submit, as required, new Samples for review and approval. Contractor shall direct specific attention in writing to revisions other than the corrections called for by Engineer on previous submittals.

6.18 *Continuing the Work*

- A. Contractor shall carry on the Work and adhere to the Progress Schedule during all disputes or disagreements with Owner. No Work shall be delayed or postponed pending resolution of any disputes or disagreements, except as permitted by Paragraph 15.04 or as Owner and Contractor may otherwise agree in writing.



6.19 *Contractor's General Warranty and Guarantee*

- A. Contractor warrants and guarantees to Owner that all Work will be in accordance with the Contract Documents and will not be defective. Engineer and its Related Entities shall be entitled to rely on representation of Contractor's warranty and guarantee.
- B. Contractor's warranty and guarantee hereunder excludes defects or damage caused by:
  - 1. abuse, modification, or improper maintenance or operation by persons other than Contractor, Subcontractors, Suppliers, or any other individual or entity for whom Contractor is responsible; or
  - 2. normal wear and tear under normal usage.
- C. Contractor's obligation to perform and complete the Work in accordance with the Contract Documents shall be absolute. None of the following will constitute an acceptance of Work that is not in accordance with the Contract Documents or a release of Contractor's obligation to perform the Work in accordance with the Contract Documents:
  - 1. observations by Engineer;
  - 2. recommendation by Engineer or payment by Owner of any progress or final payment;
  - 3. the issuance of a certificate of Substantial Completion by Engineer or any payment related thereto by Owner;
  - 4. use or occupancy of the Work or any part thereof by Owner;
  - 5. any review and approval of a Shop Drawing or Sample submittal or the issuance of a notice of acceptability by Engineer;
  - 6. any inspection, test, or approval by others; or
  - 7. any correction of defective Work by Owner.

6.20 *Indemnification*

- A. To the fullest extent permitted by Laws and Regulations, Contractor shall indemnify and hold harmless Owner and Engineer, and the officers, directors, partners, employees, agents, consultants and subcontractors of each and any of them from and against all claims, costs, losses, and damages (including but not limited to all fees and charges of engineers, architects, attorneys, and other professionals and all court or arbitration or other dispute resolution costs) arising out of or relating to the performance of the Work, provided that any such claim, cost, loss, or damage:
  - 1. is attributable to bodily injury, sickness, disease, or death, or to injury to or destruction of real or personal property (other than the Work itself), including the loss of use resulting therefrom; and
  - 2. is caused by any act or omission of Contractor, any Subcontractor, any Supplier, or any individual or entity directly or indirectly employed by any of them to perform any of the Work or anyone for whose acts any of them may be liable, regardless of whether or not caused in part by an individual or entity indemnified hereunder or whether liability is imposed upon such indemnified party by Laws or Regulations.
- B. In any and all claims against Owner or Engineer or any of their respective consultants, agents, officers, directors, partners, or employees by any employee (or the survivor or personal representative of such employee) of Contractor, any Subcontractor, any Supplier, or any individual or entity directly or indirectly

- employed by any of them to perform any of the Work, or anyone for whose acts any of them may be liable, the indemnification obligation under Paragraph 6.20.A shall not be limited in any way by any limitation on the amount or type of damages, compensation, or benefits payable by or for Contractor or any such Subcontractor, Supplier, or other individual or entity under workers' compensation acts, disability benefit acts, or other employee benefit acts.
- C. The indemnification obligations of Contractor under Paragraph 6.20.A shall not be limited in any way by the amount or types of insurance provided by Contractor under Article 5 of the General Conditions.
  - D. The indemnification obligations of Contractor under Paragraph 6.20.A shall not extend to the sole negligence or willful misconduct of Owner or Engineer or to the officers, directors, partners, employees, agents, and consultants and subcontractors of each and any of them.

6.21 *Delegation of Professional Design Services*

- A. Contractor will not be required to provide professional design services unless such services are specifically required by the Contract Documents for a portion of the Work or unless such services are required to carry out Contractor's responsibilities for construction means, methods, techniques, sequences and procedures. Contractor shall not be required to provide professional services in violation of applicable law.
- B. If professional design services or certifications by a design professional related to systems, materials or equipment are specifically required of Contractor by the Contract Documents, Owner and Engineer will specify all performance and design criteria that such services must satisfy. Contractor shall cause such services or certifications to be provided by a properly licensed professional, whose signature and seal shall appear on all drawings, calculations, specifications, certifications, Shop Drawings and other submittals prepared by such professional. Shop Drawings and other submittals related to the Work designed or certified by such professional, if prepared by others, shall bear such professional's written approval when submitted to Engineer.
- C. Owner and Engineer shall be entitled to rely upon the adequacy, accuracy and completeness of the services, certifications or approvals performed by such design professionals, provided Owner and Engineer have specified to Contractor all performance and design criteria that such services must satisfy.
- D. Pursuant to this Paragraph 6.21, Engineer's review and approval of design calculations and design drawings will be only for the limited purpose of checking for conformance with performance and design criteria given and the design concept expressed in the Contract Documents. Engineer's review and approval of Shop Drawings and other submittals (except design calculations and design drawings) will be only for the purpose stated in Paragraph 6.17.D.1.
- E. Contractor shall not be responsible for the adequacy of the performance or design criteria required by the Contract Documents.

**ARTICLE 7 - OTHER WORK AT THE SITE**

7.01 *Related Work at Site*

- A. Owner may perform other work related to the Project at the Site with Owner's employees, or via other direct contracts therefor, or have other work performed by utility owners. If such other work is not noted in the Contract Documents, then:
  - 1. written notice thereof will be given to Contractor prior to starting any such other work; and
  - 2. if Owner and Contractor are unable to agree on entitlement to or on the amount or extent, if any, of any adjustment in the Contract Price or Contract Times that should be allowed as a result of such other work, a Claim may be made therefor as provided in Paragraph 10.05.

- B. Contractor shall afford each other contractor who is a party to such a direct contract, each utility owner and Owner, if Owner is performing other work with Owner's employees, proper and safe access to the Site, a reasonable opportunity for the introduction and storage of materials and equipment and the execution of such other work, and shall properly coordinate the Work with theirs. Contractor shall do all cutting, fitting, and patching of the Work that may be required to properly connect or otherwise make its several parts come together and properly integrate with such other work. Contractor shall not endanger any work of others by cutting, excavating, or otherwise altering their work and will only cut or alter their work with the written consent of Engineer and the others whose work will be affected. The duties and responsibilities of Contractor under this Paragraph are for the benefit of such utility owners and other contractors to the extent that there are comparable provisions for the benefit of Contractor in said direct contracts between Owner and such utility owners and other contractors.
- C. If the proper execution or results of any part of Contractor's Work depends upon work performed by others under this Article 7, Contractor shall inspect such other work and promptly report to Engineer in writing any delays, defects, or deficiencies in such other work that render it unavailable or unsuitable for the proper execution and results of Contractor's Work. Contractor's failure to so report will constitute an acceptance of such other work as fit and proper for integration with Contractor's Work except for latent defects and deficiencies in such other work.

#### 7.02 *Legal Relationships*

- A. Paragraph 7.01.A is not applicable for utilities not under the control of Owner.
- B. Each other direct contract of Owner under Paragraph 7.01.A shall provide that the other contractor is liable to Owner and Contractor for the reasonable direct delay and disruption costs incurred by Contractor as a result of the other contractor's actions or inactions.
- C. Contractor shall be liable to Owner and any other contractor for the reasonable direct delay and disruption costs incurred by such other contractor as a result of Contractor's action or inactions.

### **ARTICLE 8 - OWNER'S RESPONSIBILITIES**

#### 8.01 *Communications to Contractor*

- A. Except as otherwise provided in these General Conditions, Owner shall issue all communications to Contractor through Engineer.

#### 8.02 *Furnish Data*

- A. Owner shall promptly furnish the data required of Owner under the Contract Documents.

#### 8.03 *Pay When Due*

- A. Owner shall make payments to Contractor when they are due as provided in Paragraphs 14.02.C and 14.07.C.

#### 8.04 *Lands and Easements; Reports and Tests*

- A. Owner's duties in respect of providing lands and easements and providing engineering surveys to establish reference points are set forth in Paragraphs 4.01 and 4.05. Paragraph 4.02 refers to Owner's identifying and making available to Contractor copies of reports of explorations and tests of subsurface conditions and drawings of physical conditions in or relating to existing surface or subsurface structures at or contiguous to the Site that have been utilized by Engineer in preparing the Contract Documents.

8.05 *Insurance*

- A. Owner's responsibilities, if any, in respect to purchasing and maintaining liability and property insurance are set forth in Article 5.

8.06 *Change Orders*

- A. Owner is obligated to execute Change Orders as indicated in Paragraph 10.03.

8.07 *Inspections, Tests, and Approvals*

- A. Owner's responsibility in respect to certain inspections, tests, and approvals is set forth in Paragraph 13.03.B.

8.08 *Limitations on Owner's Responsibilities*

- A. The Owner shall not supervise, direct, or have control or authority over, nor be responsible for, Contractor's means, methods, techniques, sequences, or procedures of construction, or the safety precautions and programs incident thereto, or for any failure of Contractor to comply with Laws and Regulations applicable to the performance of the Work. Owner will not be responsible for Contractor's failure to perform the Work in accordance with the Contract Documents.

8.09 *Undisclosed Hazardous Environmental Condition*

- A. Owner's responsibility in respect to an undisclosed Hazardous Environmental Condition is set forth in Paragraph 4.06.

8.10 *Evidence of Financial Arrangements*

- A. If and to the extent Owner has agreed to furnish Contractor reasonable evidence that financial arrangements have been made to satisfy Owner's obligations under the Contract Documents, Owner's responsibility in respect thereof will be as set forth in the Supplementary Conditions.

**ARTICLE 9 - ENGINEER'S STATUS DURING CONSTRUCTION**

9.01 *Owner's Representative*

- A. Engineer will be Owner's representative during the construction period. The duties and responsibilities and the limitations of authority of Engineer as Owner's representative during construction are set forth in the Contract Documents and will not be changed without written consent of Owner and Engineer.

9.02 *Visits to Site*

- A. Engineer will make visits to the Site at intervals appropriate to the various stages of construction as Engineer deems necessary in order to observe as an experienced and qualified design professional the progress that has been made and the quality of the various aspects of Contractor's executed Work. Based on information obtained during such visits and observations, Engineer, for the benefit of Owner, will determine, in general, if the Work is proceeding in accordance with the Contract Documents. Engineer will not be required to make exhaustive or continuous inspections on the Site to check the quality or quantity of the Work. Engineer's efforts will be directed toward providing for Owner a greater degree of confidence that the completed Work will conform generally to the Contract Documents. On the basis of such visits and observations, Engineer will keep Owner informed of the progress of the Work and will endeavor to guard Owner against defective Work.

- B. Engineer's visits and observations are subject to all the limitations on Engineer's authority and responsibility set forth in Paragraph 9.09. Particularly, but without limitation, during or as a result of Engineer's visits or observations of Contractor's Work, Engineer will not supervise, direct, or have control over Contractor's Work, nor shall Engineer have authority over or responsibility for the means, methods, techniques, sequences, or procedures of construction selected by Contractor, for safety precautions and programs incident to Contractor's Work in progress, nor for any failure of Contractor to comply with Laws and Regulations applicable to Contractor's furnishing and performing the Work.

9.03 *Project Representative*

- A. If Owner and Engineer agree, Engineer will furnish a Resident Project Representative to assist Engineer in providing more extensive observation of the Work. The authority and responsibilities of any such Resident Project Representative and assistants will be as provided in the Supplementary Conditions, and limitations on the responsibilities thereof will be as provided in Paragraph 9.09. If Owner designates another representative or agent to represent Owner at the Site who is not Engineer's consultant, agent or employee, the responsibilities and authority and limitations thereon of such other individual or entity will be as provided in the Supplementary Conditions.

9.04 *Authorized Variations in Work*

- A. Engineer may authorize minor variations in the Work from the requirements of the Contract Documents which do not involve an adjustment in the Contract Price or the Contract Times and are compatible with the design concept of the completed Project as a functioning whole as indicated by the Contract Documents. These may be accomplished by a Field Order and will be binding on Owner and also on Contractor, who shall perform the Work involved promptly. If Owner or Contractor believes that a Field Order justifies an adjustment in the Contract Price or Contract Times, or both, and the parties are unable to agree on entitlement to or on the amount or extent, if any, of any such adjustment, a Claim may be made therefor as provided in Paragraph 10.05.

9.05 *Rejecting Defective Work*

- A. Engineer will have authority to reject Work which Engineer believes to be defective, or that Engineer believes will not produce a completed Project that conforms to the Contract Documents or that will prejudice the integrity of the design concept of the completed Project as a functioning whole as indicated by the Contract Documents. Engineer will also have authority to require special inspection or testing of the Work as provided in Paragraph 13.04, whether or not the Work is fabricated, installed, or completed.

9.06 *Shop Drawings, Change Orders and Payments*

- A. In connection with Engineer's authority, and limitations thereof, as to Shop Drawings and Samples, see Paragraph 6.17.
- B. In connection with Engineer's authority, and limitations thereof, as to design calculations and design drawings submitted in response to a delegation of professional design services, if any, see Paragraph 6.21.
- C. In connection with Engineer's authority as to Change Orders, see Articles 10, 11, and 12.
- D. In connection with Engineer's authority as to Applications for Payment, see Article 14.

9.07 *Determinations for Unit Price Work*

- A. Engineer will determine the actual quantities and classifications of Unit Price Work performed by Contractor. Engineer will review with Contractor the Engineer's preliminary determinations on such matters before rendering a written decision thereon (by recommendation of an Application for Payment or otherwise). Engineer's written decision thereon will be final and binding (except as modified by Engineer

to reflect changed factual conditions or more accurate data) upon Owner and Contractor, subject to the provisions of Paragraph 10.05.

9.08 *Decisions on Requirements of Contract Documents and Acceptability of Work*

- A. Engineer will be the initial interpreter of the requirements of the Contract Documents and judge of the acceptability of the Work thereunder. All matters in question and other matters between Owner and Contractor arising prior to the date final payment is due relating to the acceptability of the Work, and the interpretation of the requirements of the Contract Documents pertaining to the performance of the Work, will be referred initially to Engineer in writing within 30 days of the event giving rise to the question.
- B. Engineer will, with reasonable promptness, render a written decision on the issue referred. If Owner or Contractor believes that any such decision entitles them to an adjustment in the Contract Price or Contract Times or both, a Claim may be made under Paragraph 10.05. The date of Engineer's decision shall be the date of the event giving rise to the issues referenced for the purposes of Paragraph 10.05.B.
- C. Engineer's written decision on the issue referred will be final and binding on Owner and Contractor, subject to the provisions of Paragraph 10.05.
- D. When functioning as interpreter and judge under this Paragraph 9.08, Engineer will not show partiality to Owner or Contractor and will not be liable in connection with any interpretation or decision rendered in good faith in such capacity.

9.09 *Limitations on Engineer's Authority and Responsibilities*

- A. Neither Engineer's authority or responsibility under this Article 9 or under any other provision of the Contract Documents nor any decision made by Engineer in good faith either to exercise or not exercise such authority or responsibility or the undertaking, exercise, or performance of any authority or responsibility by Engineer shall create, impose, or give rise to any duty in contract, tort, or otherwise owed by Engineer to Contractor, any Subcontractor, any Supplier, any other individual or entity, or to any surety for or employee or agent of any of them.
- B. Engineer will not supervise, direct, control, or have authority over or be responsible for Contractor's means, methods, techniques, sequences, or procedures of construction, or the safety precautions and programs incident thereto, or for any failure of Contractor to comply with Laws and Regulations applicable to the performance of the Work. Engineer will not be responsible for Contractor's failure to perform the Work in accordance with the Contract Documents.
- C. Engineer will not be responsible for the acts or omissions of Contractor or of any Subcontractor, any Supplier, or of any other individual or entity performing any of the Work.
- D. Engineer's review of the final Application for Payment and accompanying documentation and all maintenance and operating instructions, schedules, guarantees, bonds, certificates of inspection, tests and approvals, and other documentation required to be delivered by Paragraph 14.07.A will only be to determine generally that their content complies with the requirements of, and in the case of certificates of inspections, tests, and approvals that the results certified indicate compliance with the Contract Documents.
- E. The limitations upon authority and responsibility set forth in this Paragraph 9.09 shall also apply to the Resident Project Representative, if any, and assistants, if any.

## ARTICLE 10 - CHANGES IN THE WORK; CLAIMS

### 10.01 *Authorized Changes in the Work*

- A. Without invalidating the Contract and without notice to any surety, Owner may, at any time or from time to time, order additions, deletions, or revisions in the Work by a Change Order, or a Work Change Directive. Upon receipt of any such document, Contractor shall promptly proceed with the Work involved which will be performed under the applicable conditions of the Contract Documents (except as otherwise specifically provided).
- B. If Owner and Contractor are unable to agree on entitlement to, or on the amount or extent, if any, of an adjustment in the Contract Price or Contract Times, or both, that should be allowed as a result of a Work Change Directive, a Claim may be made therefor as provided in Paragraph 10.05.

### 10.02 *Unauthorized Changes in the Work*

- A. Contractor shall not be entitled to an increase in the Contract Price or an extension of the Contract Times with respect to any work performed that is not required by the Contract Documents as amended, modified, or supplemented as provided in Paragraph 3.04, except in the case of an emergency as provided in Paragraph 6.16 or in the case of uncovering Work as provided in Paragraph 13.04.B.

### 10.03 *Execution of Change Orders*

- A. Owner and Contractor shall execute appropriate Change Orders recommended by Engineer covering:
  - 1. changes in the Work which are: (i) ordered by Owner pursuant to Paragraph 10.01.A, (ii) required because of acceptance of defective Work under Paragraph 13.08.A or Owner's correction of defective Work under Paragraph 13.09, or (iii) agreed to by the parties;
  - 2. changes in the Contract Price or Contract Times which are agreed to by the parties, including any undisputed sum or amount of time for Work actually performed in accordance with a Work Change Directive; and
  - 3. changes in the Contract Price or Contract Times which embody the substance of any written decision rendered by Engineer pursuant to Paragraph 10.05; provided that, in lieu of executing any such Change Order, an appeal may be taken from any such decision in accordance with the provisions of the Contract Documents and applicable Laws and Regulations, but during any such appeal, Contractor shall carry on the Work and adhere to the Progress Schedule as provided in Paragraph 6.18.A.

### 10.04 *Notification to Surety*

- A. If notice of any change affecting the general scope of the Work or the provisions of the Contract Documents (including, but not limited to, Contract Price or Contract Times) is required by the provisions of any bond to be given to a surety, the giving of any such notice will be Contractor's responsibility. The amount of each applicable bond will be adjusted to reflect the effect of any such change.

### 10.05 *Claims*

- A. *Engineer's Decision Required:* All Claims, except those waived pursuant to Paragraph 14.09, shall be referred to the Engineer for decision. A decision by Engineer shall be required as a condition precedent to any exercise by Owner or Contractor of any rights or remedies either may otherwise have under the Contract Documents or by Laws and Regulations in respect of such Claims.

- B. *Notice:* Written notice stating the general nature of each Claim shall be delivered by the claimant to Engineer and the other party to the Contract promptly (but in no event later than 30 days) after the start of the event giving rise thereto. The responsibility to substantiate a Claim shall rest with the party making the Claim. Notice of the amount or extent of the Claim, with supporting data shall be delivered to the Engineer and the other party to the Contract within 60 days after the start of such event (unless Engineer allows additional time for claimant to submit additional or more accurate data in support of such Claim). A Claim for an adjustment in Contract Price shall be prepared in accordance with the provisions of Paragraph 12.01.B. A Claim for an adjustment in Contract Times shall be prepared in accordance with the provisions of Paragraph 12.02.B. Each Claim shall be accompanied by claimant's written statement that the adjustment claimed is the entire adjustment to which the claimant believes it is entitled as a result of said event. The opposing party shall submit any response to Engineer and the claimant within 30 days after receipt of the claimant's last submittal (unless Engineer allows additional time).
- C. *Engineer's Action:* Engineer will review each Claim and, within 30 days after receipt of the last submittal of the claimant or the last submittal of the opposing party, if any, take one of the following actions in writing:
1. deny the Claim in whole or in part,
  2. approve the Claim, or
  3. notify the parties that the Engineer is unable to resolve the Claim if, in the Engineer's sole discretion, it would be inappropriate for the Engineer to do so. For purposes of further resolution of the Claim, such notice shall be deemed a denial.
- D. In the event that Engineer does not take action on a Claim within said 30 days, the Claim shall be deemed denied.
- E. Engineer's written action under Paragraph 10.05.C or denial pursuant to Paragraphs 10.05.C.3 or 10.05.D will be final and binding upon Owner and Contractor, unless Owner or Contractor invoke the dispute resolution procedure set forth in Article 16 within 30 days of such action or denial.
- F. No Claim for an adjustment in Contract Price or Contract Times will be valid if not submitted in accordance with this Paragraph 10.05.

## **ARTICLE 11 - COST OF THE WORK; ALLOWANCES; UNIT PRICE WORK**

### **11.01 *Cost of the Work***

- A. *Costs Included:* The term Cost of the Work means the sum of all costs, except those excluded in Paragraph 11.01.B, necessarily incurred and paid by Contractor in the proper performance of the Work. When the value of any Work covered by a Change Order or when a Claim for an adjustment in Contract Price is determined on the basis of Cost of the Work, the costs to be reimbursed to Contractor will be only those additional or incremental costs required because of the change in the Work or because of the event giving rise to the Claim. Except as otherwise may be agreed to in writing by Owner, such costs shall be in amounts no higher than those prevailing in the locality of the Project, shall include only the following items, and shall not include any of the costs itemized in Paragraph 11.01.B.
1. Payroll costs for employees in the direct employ of Contractor in the performance of the Work under schedules of job classifications agreed upon by Owner and Contractor. Such employees shall include, without limitation, superintendents, foremen, and other personnel employed full time at the Site. Payroll costs for employees not employed full time on the Work shall be apportioned on the basis of their time spent on the Work. Payroll costs shall include, but not be limited to, salaries and wages plus the cost of fringe benefits, which shall include social security contributions, unemployment,



excise, and payroll taxes, workers' compensation, health and retirement benefits, bonuses, sick leave, vacation and holiday pay applicable thereto. The expenses of performing Work outside of regular working hours, on Saturday, Sunday, or legal holidays, shall be included in the above to the extent authorized by Owner.

2. Cost of all materials and equipment furnished and incorporated in the Work, including costs of transportation and storage thereof, and Suppliers' field services required in connection therewith. All cash discounts shall accrue to Contractor unless Owner deposits funds with Contractor with which to make payments, in which case the cash discounts shall accrue to Owner. All trade discounts, rebates and refunds and returns from sale of surplus materials and equipment shall accrue to Owner, and Contractor shall make provisions so that they may be obtained.
3. Payments made by Contractor to Subcontractors for Work performed by Subcontractors. If required by Owner, Contractor shall obtain competitive bids from subcontractors acceptable to Owner and Contractor and shall deliver such bids to Owner, who will then determine, with the advice of Engineer, which bids, if any, will be acceptable. If any subcontract provides that the Subcontractor is to be paid on the basis of Cost of the Work plus a fee, the Subcontractor's Cost of the Work and fee shall be determined in the same manner as Contractor's Cost of the Work and fee as provided in this Paragraph 11.01.
4. Costs of special consultants (including but not limited to Engineers, architects, testing laboratories, surveyors, attorneys, and accountants) employed for services specifically related to the Work.
5. Supplemental costs including the following:
  - a. The proportion of necessary transportation, travel, and subsistence expenses of Contractor's employees incurred in discharge of duties connected with the Work.
  - b. Cost, including transportation and maintenance, of all materials, supplies, equipment, machinery, appliances, office, and temporary facilities at the Site, and hand tools not owned by the workers, which are consumed in the performance of the Work, and cost, less market value, of such items used but not consumed which remain the property of Contractor.
  - c. Rentals of all construction equipment and machinery, and the parts thereof whether rented from Contractor or others in accordance with rental agreements approved by Owner with the advice of Engineer, and the costs of transportation, loading, unloading, assembly, dismantling, and removal thereof. All such costs shall be in accordance with the terms of said rental agreements. The rental of any such equipment, machinery, or parts shall cease when the use thereof is no longer necessary for the Work.
  - d. Sales, consumer, use, and other similar taxes related to the Work, and for which Contractor is liable, imposed by Laws and Regulations.
  - e. Deposits lost for causes other than negligence of Contractor, any Subcontractor, or anyone directly or indirectly employed by any of them or for whose acts any of them may be liable, and royalty payments and fees for permits and licenses.
  - f. Losses and damages (and related expenses) caused by damage to the Work, not compensated by insurance or otherwise, sustained by Contractor in connection with the performance of the Work (except losses and damages within the deductible amounts of property insurance established in accordance with Paragraph 5.06.D), provided such losses and damages have resulted from causes other than the negligence of Contractor, any Subcontractor, or anyone directly or indirectly employed by any of them or for whose acts any of them may be liable. Such losses shall include settlements made with the written consent and approval of Owner. No such losses, damages, and

expenses shall be included in the Cost of the Work for the purpose of determining Contractor's fee.

- g. The cost of utilities, fuel, and sanitary facilities at the Site.
- h. Minor expenses such as telegrams, long distance telephone calls, telephone service at the Site, expressage, and similar petty cash items in connection with the Work.
- i. The costs of premiums for all bonds and insurance Contractor is required by the Contract Documents to purchase and maintain.

B. *Costs Excluded:* The term Cost of the Work shall not include any of the following items:

- 1. Payroll costs and other compensation of Contractor's officers, executives, principals (of partnerships and sole proprietorships), general managers, safety managers, engineers, architects, estimators, attorneys, auditors, accountants, purchasing and contracting agents, expeditors, timekeepers, clerks, and other personnel employed by Contractor, whether at the Site or in Contractor's principal or branch office for general administration of the Work and not specifically included in the agreed upon schedule of job classifications referred to in Paragraph 11.01.A.1 or specifically covered by Paragraph 11.01.A.4, all of which are to be considered administrative costs covered by the Contractor's fee.
- 2. Expenses of Contractor's principal and branch offices other than Contractor's office at the Site.
- 3. Any part of Contractor's capital expenses, including interest on Contractor's capital employed for the Work and charges against Contractor for delinquent payments.
- 4. Costs due to the negligence of Contractor, any Subcontractor, or anyone directly or indirectly employed by any of them or for whose acts any of them may be liable, including but not limited to, the correction of defective Work, disposal of materials or equipment wrongly supplied, and making good any damage to property.
- 5. Other overhead or general expense costs of any kind and the costs of any item not specifically and expressly included in Paragraphs 11.01.A and 11.01.B.

C. *Contractor's Fee:* When all the Work is performed on the basis of cost-plus, Contractor's fee shall be determined as set forth in the Agreement. When the value of any Work covered by a Change Order or when a Claim for an adjustment in Contract Price is determined on the basis of Cost of the Work, Contractor's fee shall be determined as set forth in Paragraph 12.01.C.

D. *Documentation:* Whenever the Cost of the Work for any purpose is to be determined pursuant to Paragraphs 11.01.A and 11.01.B, Contractor will establish and maintain records thereof in accordance with generally accepted accounting practices and submit in a form acceptable to Engineer an itemized cost breakdown together with supporting data.

#### 11.02 Allowances

A. It is understood that Contractor has included in the Contract Price all allowances so named in the Contract Documents and shall cause the Work so covered to be performed for such sums and by such persons or entities as may be acceptable to Owner and Engineer.

B. *Cash Allowances*

1. Contractor agrees that:
  - a. the cash allowances include the cost to Contractor (less any applicable trade discounts) of materials and equipment required by the allowances to be delivered at the Site, and all applicable taxes; and
  - b. Contractor's costs for unloading and handling on the Site, labor, installation, overhead, profit, and other expenses contemplated for the cash allowances have been included in the Contract Price and not in the allowances, and no demand for additional payment on account of any of the foregoing will be valid.

C. *Contingency Allowance*

1. Contractor agrees that a contingency allowance, if any, is for the sole use of Owner to cover unanticipated costs.

- D. Prior to final payment, an appropriate Change Order will be issued as recommended by Engineer to reflect actual amounts due Contractor on account of Work covered by allowances, and the Contract Price shall be correspondingly adjusted.

11.03 *Unit Price Work*

- A. Where the Contract Documents provide that all or part of the Work is to be Unit Price Work, initially the Contract Price will be deemed to include for all Unit Price Work an amount equal to the sum of the unit price for each separately identified item of Unit Price Work times the estimated quantity of each item as indicated in the Agreement.
- B. The estimated quantities of items of Unit Price Work are not guaranteed and are solely for the purpose of comparison of Bids and determining an initial Contract Price. Determinations of the actual quantities and classifications of Unit Price Work performed by Contractor will be made by Engineer subject to the provisions of Paragraph 9.07.
- C. Each unit price will be deemed to include an amount considered by Contractor to be adequate to cover Contractor's overhead and profit for each separately identified item.
- D. Owner or Contractor may make a Claim for an adjustment in the Contract Price in accordance with Paragraph 10.05 if:
  1. the quantity of any item of Unit Price Work performed by Contractor differs materially and significantly from the estimated quantity of such item indicated in the Agreement; and
  2. there is no corresponding adjustment with respect to any other item of Work; and
  3. Contractor believes that Contractor is entitled to an increase in Contract Price as a result of having incurred additional expense or Owner believes that Owner is entitled to a decrease in Contract Price and the parties are unable to agree as to the amount of any such increase or decrease.

## ARTICLE 12 - CHANGE OF CONTRACT PRICE; CHANGE OF CONTRACT TIMES

### 12.01 *Change of Contract Price*

- A. The Contract Price may only be changed by a Change Order. Any Claim for an adjustment in the Contract Price shall be based on written notice submitted by the party making the Claim to the Engineer and the other party to the Contract in accordance with the provisions of Paragraph 10.05.
- B. The value of any Work covered by a Change Order or of any Claim for an adjustment in the Contract Price will be determined as follows:
  - 1. where the Work involved is covered by unit prices contained in the Contract Documents, by application of such unit prices to the quantities of the items involved (subject to the provisions of Paragraph 11.03); or
  - 2. where the Work involved is not covered by unit prices contained in the Contract Documents, by a mutually agreed lump sum (which may include an allowance for overhead and profit not necessarily in accordance with Paragraph 12.01.C.2); or
  - 3. where the Work involved is not covered by unit prices contained in the Contract Documents and agreement to a lump sum is not reached under Paragraph 12.01.B.2, on the basis of the Cost of the Work (determined as provided in Paragraph 11.01) plus a Contractor's fee for overhead and profit (determined as provided in Paragraph 12.01.C).
- C. *Contractor's Fee:* The Contractor's fee for overhead and profit shall be determined as follows:
  - 1. a mutually acceptable fixed fee; or
  - 2. if a fixed fee is not agreed upon, then a fee based on the following percentages of the various portions of the Cost of the Work:
    - a. for costs incurred under Paragraphs 11.01.A.1 and 11.01.A.2, the Contractor's fee shall be 15 percent;
    - b. for costs incurred under Paragraph 11.01.A.3, the Contractor's fee shall be five percent;
    - c. where one or more tiers of subcontracts are on the basis of Cost of the Work plus a fee and no fixed fee is agreed upon, the intent of Paragraph 12.01.C.2.a is that the Subcontractor who actually performs the Work, at whatever tier, will be paid a fee of 15 percent of the costs incurred by such Subcontractor under Paragraphs 11.01.A.1 and 11.01.A.2 and that any higher tier Subcontractor and Contractor will each be paid a fee of five percent of the amount paid to the next lower tier Subcontractor;
    - d. no fee shall be payable on the basis of costs itemized under Paragraphs 11.01.A.4, 11.01.A.5, and 11.01.B;
    - e. the amount of credit to be allowed by Contractor to Owner for any change which results in a net decrease in cost will be the amount of the actual net decrease in cost plus a deduction in Contractor's fee by an amount equal to five percent of such net decrease; and
    - f. when both additions and credits are involved in any one change, the adjustment in Contractor's fee shall be computed on the basis of the net change in accordance with Paragraphs 12.01.C.2.a through 12.01.C.2.e, inclusive.

12.02 *Change of Contract Times*

- A. The Contract Times may only be changed by a Change Order. Any Claim for an adjustment in the Contract Times shall be based on written notice submitted by the party making the Claim to the Engineer and the other party to the Contract in accordance with the provisions of Paragraph 10.05.
- B. Any adjustment of the Contract Times covered by a Change Order or any Claim for an adjustment in the Contract Times will be determined in accordance with the provisions of this Article 12.

12.03 *Delays*

- A. Where Contractor is prevented from completing any part of the Work within the Contract Times due to delay beyond the control of Contractor, the Contract Times will be extended in an amount equal to the time lost due to such delay if a Claim is made therefor as provided in Paragraph 12.02.A. Delays beyond the control of Contractor shall include, but not be limited to, acts or neglect by Owner, acts or neglect of utility owners or other contractors performing other work as contemplated by Article 7, fires, floods, epidemics, abnormal weather conditions, or acts of God.
- B. Contractor shall not be entitled to an adjustment in Contract Price or Contract Times for delays within the control of Contractor. Delays attributable to and within the control of a Subcontractor or Supplier shall be deemed to be delays within the control of Contractor.
- C. If Owner, Engineer, or utility owners performing other work for Owner as contemplated by Article 7, or anyone for whom Owner is responsible, delays, disrupts, or interferes with the performance or progress of the Work, then Contractor shall be entitled to an equitable adjustment in the Contract Price or the Contract Times, or both. Contractor's entitlement to an adjustment of the Contract Times is conditioned on such adjustment being essential to Contractor's ability to complete the Work within the Contract Times.
- D. If Contractor is delayed in the performance or progress of the Work by fire, flood, epidemic, abnormal weather conditions, acts of God, acts or failures to act of other contractors or utility owners, or other causes not the fault of and beyond control of Owner and Contractor, then Contractor shall be entitled to an equitable adjustment in Contract Times, if such adjustment is essential to Contractor's ability to complete the Work within the Contract Times. Such an adjustment shall be Contractor's sole and exclusive remedy for the delays described in this Paragraph 12.03.D.
- E. Owner, Engineer and the Related Entities of each of them shall not be liable to Contractor for any claims, costs, losses, or damages (including but not limited to all fees and charges of engineers, architects, attorneys, and other professionals and all court or arbitration or other dispute resolution costs) sustained by Contractor on or in connection with any other project or anticipated project.

**ARTICLE 13 - TESTS AND INSPECTIONS; CORRECTION, REMOVAL OR ACCEPTANCE OF DEFECTIVE WORK**

13.01 *Notice of Defects*

- A. Prompt notice of all defective Work of which Owner or Engineer has actual knowledge will be given to Contractor. All defective Work may be rejected, corrected, or accepted as provided in this Article 13.

13.02 *Access to Work*

- A. Owner, Engineer, their consultants and other representatives and personnel of Owner, independent testing laboratories, and governmental agencies with jurisdictional interests will have access to the Site and the Work at all times for their observation, inspecting, and testing. Contractor shall provide them proper and safe conditions for such access and advise them of Contractor's Site safety procedures and programs so that

they may comply therewith as applicable. Contractor shall provide Owner, Engineer, and their consultants with every reasonable facility for ascertaining full knowledge respecting the progress, workmanship and character of materials used and employed in the work.

13.03 *Tests and Inspections*

- A. Contractor shall give Engineer timely notice of readiness of the Work for all required inspections, tests, or approvals and shall cooperate with inspection and testing personnel to facilitate required inspections or tests. The inspection of the work shall not relieve the Contractor of any of his obligations to fulfill the contract as prescribed.
- B. Owner shall employ and pay for the services of an independent testing laboratory to perform all inspections, tests, or approvals required by the Contract Documents except:
  - 1. for inspections, tests, or approvals covered by Paragraphs 13.03.C and 13.03.D below;
  - 2. that costs incurred in connection with tests or inspections conducted pursuant to Paragraph 13.04.B shall be paid as provided in said Paragraph 13.04.C; and
  - 3. as otherwise specifically provided in the Contract Documents.
- C. If Laws or Regulations of any public body having jurisdiction require any Work (or part thereof) specifically to be inspected, tested, or approved by an employee or other representative of such public body, Contractor shall assume full responsibility for arranging and obtaining such inspections, tests, or approvals, pay all costs in connection therewith, and furnish Engineer the required certificates of inspection or approval.
- D. Contractor shall be responsible for arranging and obtaining and shall pay all costs in connection with any inspections, tests, or approvals required for Owner's and Engineer's acceptance of materials or equipment to be incorporated in the Work; or acceptance of materials, mix designs, or equipment submitted for approval prior to Contractor's purchase thereof for incorporation in the Work. Such inspections, tests, or approvals shall be performed by organizations acceptable to Owner and Engineer.
- E. No materials shall be applied until approved by the Engineer. All areas which are to be covered or painted shall be inspected and approved by the Engineer prior to covering or painting, and the Contractor shall give due notice in advance to the Engineer so that proper inspection may be provided. If any Work (or the work of others) that is to be inspected, tested, or approved is covered by Contractor without written concurrence of Engineer, it must, if requested by Engineer, be uncovered for observation.
- F. Uncovering Work as provided in Paragraph 13.03.E shall be at Contractor's expense unless Contractor has given Engineer timely notice of Contractor's intention to cover the same and Engineer has not acted with reasonable promptness in response to such notice.

13.04 *Uncovering Work*

- A. If any Work is covered contrary to the written request of Engineer, it must, if requested by Engineer, be uncovered for Engineer's observation and replaced at Contractor's expense.
- B. If Engineer considers it necessary or advisable that covered Work be observed by Engineer or inspected or tested by others, Contractor, at Engineer's request, shall uncover, expose, or otherwise make available for observation, inspection, or testing as Engineer may require, that portion of the Work in question, furnishing all necessary labor, material, and equipment.
- C. If it is found that the uncovered Work is defective, Contractor shall pay all claims, costs, losses, and damages (including but not limited to all fees and charges of engineers, architects, attorneys, and other

professionals and all court or arbitration or other dispute resolution costs) arising out of or relating to such uncovering, exposure, observation, inspection, and testing, and of satisfactory replacement or reconstruction (including but not limited to all costs of repair or replacement of work of others); and Owner shall be entitled to an appropriate decrease in the Contract Price. If the parties are unable to agree as to the amount thereof, Owner may make a Claim therefor as provided in Paragraph 10.05.

- D. If, the uncovered Work is not found to be defective, Contractor shall be allowed an increase in the Contract Price or an extension of the Contract Times, or both, directly attributable to such uncovering, exposure, observation, inspection, testing, replacement, and reconstruction. If the parties are unable to agree as to the amount or extent thereof, Contractor may make a Claim therefor as provided in Paragraph 10.05.

13.05 *Owner May Stop the Work*

- A. If the Work is defective, or Contractor fails to supply sufficient skilled workers or suitable materials or equipment, or fails to perform the Work in such a way that the completed Work will conform to the Contract Documents, Owner may order Contractor to stop the Work, or any portion thereof, until the cause for such order has been eliminated; however, this right of Owner to stop the Work shall not give rise to any duty on the part of Owner to exercise this right for the benefit of Contractor, any Subcontractor, any Supplier, any other individual or entity, or any surety for, or employee or agent of any of them.

13.06 *Correction or Removal of Defective Work*

- A. Promptly after receipt of notice, Contractor shall correct all defective Work, whether or not fabricated, installed, completed, or previously inspected, or, if the Work has been rejected by Engineer, remove it from the Project and replace it with Work that is not defective. Contractor shall pay all claims, costs, losses, and damages (including but not limited to all fees and charges of engineers, architects, attorneys, and other professionals and all court or arbitration or other dispute resolution costs) arising out of or relating to such correction or removal (including but not limited to all costs of repair or replacement of work of others).
- B. When correcting defective Work under the terms of this Paragraph 13.06 or Paragraph 13.07, Contractor shall take no action that would void or otherwise impair Owner's special warranty and guarantee, if any, on said Work.

13.07 *Correction Period*

- A. If within one year after the date of Substantial Completion (or such longer period of time as may be prescribed by the terms of any applicable special guarantee required by the Contract Documents) or by any specific provision of the Contract Documents, any Work is found to be defective, or if the repair of any damages to the land or areas made available for Contractor's use by Owner or permitted by Laws and Regulations as contemplated in Paragraph 6.11.A is found to be defective, Contractor shall promptly, without cost to Owner and in accordance with Owner's written instructions:
  - 1. repair such defective land or areas; or
  - 2. correct such defective Work; or
  - 3. if the defective Work has been rejected by Owner, remove it from the Project and replace it with Work that is not defective, and
  - 4. satisfactorily correct or repair or remove and replace any damage to other Work, to the work of others or other land or areas resulting therefrom.
- B. If Contractor does not promptly comply with the terms of Owner's written instructions, or in an emergency where delay would cause serious risk of loss or damage, Owner may have the defective Work corrected or repaired or may have the rejected Work removed and replaced. All claims, costs, losses, and damages

(including but not limited to all fees and charges of engineers, architects, attorneys, and other professionals and all court or arbitration or other dispute resolution costs) arising out of or relating to such correction or repair or such removal and replacement (including but not limited to all costs of repair or replacement of work of others) will be paid by Contractor.

- C. In special circumstances where a particular item of equipment is placed in continuous service before Substantial Completion of all the Work, the correction period for that item may start to run from an earlier date if so provided in the Specifications.
- D. Where defective Work (and damage to other Work resulting therefrom) has been corrected or removed and replaced under this Paragraph 13.07, the correction period hereunder with respect to such Work will be extended for an additional period of one year after such correction or removal and replacement has been satisfactorily completed.
- E. Contractor's obligations under this Paragraph 13.07 are in addition to any other obligation or warranty. The provisions of this Paragraph 13.07 shall not be construed as a substitute for or a waiver of the provisions of any applicable statute of limitation or repose.

13.08 *Acceptance of Defective Work*

- A. If, instead of requiring correction or removal and replacement of defective Work, Owner (and, prior to Engineer's recommendation of final payment, Engineer) prefers to accept it, Owner may do so. Contractor shall pay all claims, costs, losses, and damages (including but not limited to all fees and charges of engineers, architects, attorneys, and other professionals and all court or arbitration or other dispute resolution costs) attributable to Owner's evaluation of and determination to accept such defective Work (such costs to be approved by Engineer as to reasonableness) and the diminished value of the Work to the extent not otherwise paid by Contractor pursuant to this sentence. If any such acceptance occurs prior to Engineer's recommendation of final payment, a Change Order will be issued incorporating the necessary revisions in the Contract Documents with respect to the Work, and Owner shall be entitled to an appropriate decrease in the Contract Price, reflecting the diminished value of Work so accepted. If the parties are unable to agree as to the amount thereof, Owner may make a Claim therefor as provided in Paragraph 10.05. If the acceptance occurs after such recommendation, an appropriate amount will be paid by Contractor to Owner.

13.09 *Owner May Correct Defective Work*

- A. If Contractor fails within a reasonable time after written notice from Engineer to correct defective Work or to remove and replace rejected Work as required by Engineer in accordance with Paragraph 13.06.A, or if Contractor fails to perform the Work in accordance with the Contract Documents, or if Contractor fails to comply with any other provision of the Contract Documents, Owner may, after seven days written notice to Contractor, correct or remedy any such deficiency.
- B. In exercising the rights and remedies under this Paragraph 13.09, Owner shall proceed expeditiously. In connection with such corrective or remedial action, Owner may exclude Contractor from all or part of the Site, take possession of all or part of the Work and suspend Contractor's services related thereto, take possession of Contractor's tools, appliances, construction equipment and machinery at the Site, and incorporate in the Work all materials and equipment stored at the Site or for which Owner has paid Contractor but which are stored elsewhere. Contractor shall allow Owner, Owner's representatives, agents and employees, Owner's other contractors, and Engineer and Engineer's consultants access to the Site to enable Owner to exercise the rights and remedies under this Paragraph.
- C. All claims, costs, losses, and damages (including but not limited to all fees and charges of engineers, architects, attorneys, and other professionals and all court or arbitration or other dispute resolution costs) incurred or sustained by Owner in exercising the rights and remedies under this Paragraph 13.09 will be charged against Contractor, and a Change Order will be issued incorporating the necessary revisions in the



Contract Documents with respect to the Work; and Owner shall be entitled to an appropriate decrease in the Contract Price. If the parties are unable to agree as to the amount of the adjustment, Owner may make a Claim therefor as provided in Paragraph 10.05. Such claims, costs, losses and damages will include but not be limited to all costs of repair, or replacement of work of others destroyed or damaged by correction, removal, or replacement of Contractor's defective Work.

- D. Contractor shall not be allowed an extension of the Contract Times because of any delay in the performance of the Work attributable to the exercise by Owner of Owner's rights and remedies under this Paragraph 13.09.

## **ARTICLE 14 - PAYMENTS TO CONTRACTOR AND COMPLETION**

### *14.01 Schedule of Value*

- A. The Schedule of Values established as provided in Paragraph 2.07.A will serve as the basis for progress payments and will be incorporated into a form of Application for Payment acceptable to Engineer. Progress payments on account of Unit Price Work will be based on the number of units completed.

### *14.02 Progress Payments*

#### *A. Applications for Payments*

1. At least 20 days before the date established in the Agreement for each progress payment (but not more often than once a month), Contractor shall submit to Engineer for review an Application for Payment filled out and signed by Contractor covering the Work completed as of the date of the Application and accompanied by such supporting documentation as is required by the Contract Documents. If payment is requested on the basis of materials and equipment not incorporated in the Work but delivered and suitably stored at the Site or at another location agreed to in writing, the Application for Payment shall also be accompanied by a bill of sale, invoice, or other documentation warranting that Owner has received the materials and equipment free and clear of all Liens and evidence that the materials and equipment are covered by appropriate property insurance or other arrangements to protect Owner's interest therein, all of which must be satisfactory to Owner.
2. Beginning with the second Application for Payment, each Application shall include an affidavit of Contractor stating that all previous progress payments received on account of the Work have been applied on account to discharge Contractor's legitimate obligations associated with prior Applications for Payment.
3. The amount of retainage with respect to progress payments will be as stipulated in the Agreement.

#### *B. Review of Applications*

1. Engineer will, within 10 days after receipt of each Application for Payment, either indicate in writing a recommendation of payment and present the Application to Owner or return the Application to Contractor indicating in writing Engineer's reasons for refusing to recommend payment. In the latter case, Contractor may make the necessary corrections and resubmit the Application.
2. Engineer's recommendation of any payment requested in an Application for Payment will constitute a representation by Engineer to Owner, based on Engineer's observations on the Site of the executed Work as an experienced and qualified design professional and on Engineer's review of the Application for Payment and the accompanying data and schedules, that to the best of Engineer's knowledge, information and belief:
  - a. the Work has progressed to the point indicated;

- b. the quality of the Work is generally in accordance with the Contract Documents (subject to an evaluation of the Work as a functioning whole prior to or upon Substantial Completion, to the results of any subsequent tests called for in the Contract Documents, to a final determination of quantities and classifications for Unit Price Work under Paragraph 9.07, and to any other qualifications stated in the recommendation); and
    - c. the conditions precedent to Contractor's being entitled to such payment appear to have been fulfilled in so far as it is Engineer's responsibility to observe the Work.
- 3. By recommending any such payment Engineer will not thereby be deemed to have represented that:
  - a. inspections made to check the quality or the quantity of the Work as it has been performed have been exhaustive, extended to every aspect of the Work in progress, or involved detailed inspections of the Work beyond the responsibilities specifically assigned to Engineer in the Contract Documents; or
  - b. that there may not be other matters or issues between the parties that might entitle Contractor to be paid additionally by Owner or entitle Owner to withhold payment to Contractor.
- 4. Neither Engineer's review of Contractor's Work for the purposes of recommending payments nor Engineer's recommendation of any payment, including final payment, will impose responsibility on Engineer:
  - a. to supervise, direct, or control the Work, or
  - b. for the means, methods, techniques, sequences, or procedures of construction, or the safety precautions and programs incident thereto, or
  - c. for Contractor's failure to comply with Laws and Regulations applicable to Contractor's performance of the Work, or
  - d. to make any examination to ascertain how or for what purposes Contractor has used the moneys paid on account of the Contract Price, or
  - e. to determine that title to any of the Work, materials, or equipment has passed to Owner free and clear of any Liens.
- 5. Engineer may refuse to recommend the whole or any part of any payment if, in Engineer's opinion, it would be incorrect to make the representations to Owner stated in Paragraph 14.02.B.2. Engineer may also refuse to recommend any such payment or, because of subsequently discovered evidence or the results of subsequent inspections or tests, revise or revoke any such payment recommendation previously made, to such extent as may be necessary in Engineer's opinion to protect Owner from loss because:
  - a. the Work is defective, or completed Work has been damaged, requiring correction or replacement;
  - b. the Contract Price has been reduced by Change Orders;
  - c. Owner has been required to correct defective Work or complete Work in accordance with Paragraph 13.09; or
  - d. Engineer has actual knowledge of the occurrence of any of the events enumerated in Paragraph 15.02.A.

C. *Payment Becomes Due*

1. Thirty days after presentation of the Application for Payment to Owner with Engineer's recommendation, the amount recommended will (subject to the provisions of Paragraph 14.02.D) become due, and when due will be paid by Owner to Contractor.

D. *Reduction in Payment*

1. Owner may refuse to make payment of the full amount recommended by Engineer because:
  - a. claims have been made against Owner on account of Contractor's performance or furnishing of the Work;
  - b. Liens have been filed in connection with the Work, except where Contractor has delivered a specific bond satisfactory to Owner to secure the satisfaction and discharge of such Liens;
  - c. there are other items entitling Owner to a set-off against the amount recommended; or
  - d. Owner has actual knowledge of the occurrence of any of the events enumerated in Paragraphs 14.02.B.5.a through 14.02.B.5.c or Paragraph 15.02.A.
2. If Owner refuses to make payment of the full amount recommended by Engineer, Owner will give Contractor immediate written notice (with a copy to Engineer) stating the reasons for such action and promptly pay Contractor any amount remaining after deduction of the amount so withheld. Owner shall promptly pay Contractor the amount so withheld, or any adjustment thereto agreed to by Owner and Contractor, when Contractor corrects to Owner's satisfaction the reasons for such action.
3. If it is subsequently determined that Owner's refusal of payment was not justified, the amount wrongfully withheld shall be treated as an amount due as determined by Paragraph 14.02.C.1.

14.03 *Contractor's Warranty of Title*

- A. Contractor warrants and guarantees that title to all Work, materials, and equipment covered by any Application for Payment, whether incorporated in the Project or not, will pass to Owner no later than the time of payment free and clear of all Liens.

14.04 *Substantial Completion*

- A. When Contractor considers the entire Work ready for its intended use Contractor shall notify Owner and Engineer in writing that the entire Work is substantially complete (except for items specifically listed by Contractor as incomplete) and request that Engineer issue a certificate of Substantial Completion.
- B. Promptly after Contractor's notification, Owner, Contractor, and Engineer shall make an inspection of the Work to determine the status of completion. If Engineer does not consider the Work substantially complete, Engineer will notify Contractor in writing giving the reasons therefor.
- C. If Engineer considers the Work substantially complete, Engineer will deliver to Owner a tentative certificate of Substantial Completion which shall fix the date of Substantial Completion. There shall be attached to the certificate a tentative list of items to be completed or corrected before final payment. Owner shall have seven days after receipt of the tentative certificate during which to make written objection to Engineer as to any provisions of the certificate or attached list. If, after considering such objections, Engineer concludes that the Work is not substantially complete, Engineer will within 14 days after submission of the tentative certificate to Owner notify Contractor in writing, stating the reasons therefor. If, after consideration of Owner's objections, Engineer considers the Work substantially complete, Engineer will within said 14 days execute and deliver to Owner and Contractor a definitive certificate of Substantial

Completion (with a revised tentative list of items to be completed or corrected) reflecting such changes from the tentative certificate as Engineer believes justified after consideration of any objections from Owner.

- D. At the time of delivery of the tentative certificate of Substantial Completion, Engineer will deliver to Owner and Contractor a written recommendation as to division of responsibilities pending final payment between Owner and Contractor with respect to security, operation, safety, and protection of the Work, maintenance, heat, utilities, insurance, and warranties and guarantees. Unless Owner and Contractor agree otherwise in writing and so inform Engineer in writing prior to Engineer's issuing the definitive certificate of Substantial Completion, Engineer's aforesaid recommendation will be binding on Owner and Contractor until final payment.
- E. Owner shall have the right to exclude Contractor from the Site after the date of Substantial Completion subject to allowing Contractor reasonable access to complete or correct items on the tentative list.

#### 14.05 *Partial Utilization*

- A. Prior to Substantial Completion of all the Work, Owner may use or occupy any substantially completed part of the Work which has specifically been identified in the Contract Documents, or which Owner, Engineer, and Contractor agree constitutes a separately functioning and usable part of the Work that can be used by Owner for its intended purpose without significant interference with Contractor's performance of the remainder of the Work, subject to the following conditions.
  - 1. Owner at any time may request Contractor in writing to permit Owner to use or occupy any such part of the Work which Owner believes to be ready for its intended use and substantially complete. If and when Contractor agrees that such part of the Work is substantially complete, Contractor will certify to Owner and Engineer that such part of the Work is substantially complete and request Engineer to issue a certificate of Substantial Completion for that part of the Work.
  - 2. Contractor at any time may notify Owner and Engineer in writing that Contractor considers any such part of the Work ready for its intended use and substantially complete and request Engineer to issue a certificate of Substantial Completion for that part of the Work.
  - 3. Within a reasonable time after either such request, Owner, Contractor, and Engineer shall make an inspection of that part of the Work to determine its status of completion. If Engineer does not consider that part of the Work to be substantially complete, Engineer will notify Owner and Contractor in writing giving the reasons therefor. If Engineer considers that part of the Work to be substantially complete, the provisions of Paragraph 14.04 will apply with respect to certification of Substantial Completion of that part of the Work and the division of responsibility in respect thereof and access thereto.
  - 4. No use or occupancy or separate operation of part of the Work may occur prior to compliance with the requirements of Paragraph 5.10 regarding property insurance.

#### 14.06 *Final Inspection*

- A. Upon written notice from Contractor that the entire Work or an agreed portion thereof is complete, Engineer will promptly make a final inspection with Owner and Contractor and will notify Contractor in writing of all particulars in which this inspection reveals that the Work is incomplete or defective. Contractor shall immediately take such measures as are necessary to complete such Work or remedy such deficiencies.

#### 14.07 *Final Payment*

- A. *Application for Payment*

1. After Contractor has, in the opinion of Engineer, satisfactorily completed all corrections identified during the final inspection and has delivered, in accordance with the Contract Documents, all maintenance and operating instructions, schedules, guarantees, bonds, certificates or other evidence of insurance, certificates of inspection, marked-up record documents (as provided in Paragraph 6.12), and other documents, Contractor may make application for final payment following the procedure for progress payments.
2. The final Application for Payment shall be accompanied (except as previously delivered) by:
  - a. all documentation called for in the Contract Documents, including but not limited to the evidence of insurance required by Paragraph 5.04.B.7;
  - b. consent of the surety, if any, to final payment;
  - c. a list of all Claims against Owner that Contractor believes are unsettled; and
  - d. complete and legally effective releases or waivers (satisfactory to Owner) of all Lien rights arising out of or Liens filed in connection with the Work.
3. In lieu of the releases or waivers of Liens specified in Paragraph 14.07.A.2 and as approved by Owner, Contractor may furnish receipts or releases in full and an affidavit of Contractor that: (i) the releases and receipts include all labor, services, material, and equipment for which a Lien could be filed; and (ii) all payrolls, material and equipment bills, and other indebtedness connected with the Work for which Owner or Owner's property might in any way be responsible have been paid or otherwise satisfied. If any Subcontractor or Supplier fails to furnish such a release or receipt in full, Contractor may furnish a bond or other collateral satisfactory to Owner to indemnify Owner against any Lien.

*B. Engineer's Review of Application and Acceptance*

1. If, on the basis of Engineer's observation of the Work during construction and final inspection, and Engineer's review of the final Application for Payment and accompanying documentation as required by the Contract Documents, Engineer is satisfied that the Work has been completed and Contractor's other obligations under the Contract Documents have been fulfilled, Engineer will, within ten days after receipt of the final Application for Payment, indicate in writing Engineer's recommendation of payment and present the Application for Payment to Owner for payment. At the same time Engineer will also give written notice to Owner and Contractor that the Work is acceptable subject to the provisions of Paragraph 14.09. Otherwise, Engineer will return the Application for Payment to Contractor, indicating in writing the reasons for refusing to recommend final payment, in which case Contractor shall make the necessary corrections and resubmit the Application for Payment.

*C. Payment Becomes Due*

1. Thirty days after the presentation to Owner of the Application for Payment and accompanying documentation, the amount recommended by Engineer, less any sum Owner is entitled to set off against Engineer's recommendation, including but not limited to liquidated damages, will become due and will be paid by Owner to Contractor.

14.08 *Final Completion Delayed*

- A. If, through no fault of Contractor, final completion of the Work is significantly delayed, and if Engineer so confirms, Owner shall, upon receipt of Contractor's final Application for Payment (for Work fully completed and accepted) and recommendation of Engineer, and without terminating the Contract, make payment of the balance due for that portion of the Work fully completed and accepted. If the remaining

balance to be held by Owner for Work not fully completed or corrected is less than the retainage stipulated in the Agreement, and if bonds have been furnished as required in Paragraph 5.01, the written consent of the surety to the payment of the balance due for that portion of the Work fully completed and accepted shall be submitted by Contractor to Engineer with the Application for such payment. Such payment shall be made under the terms and conditions governing final payment, except that it shall not constitute a waiver of Claims.

14.09 *Waiver of Claims*

- A. The making and acceptance of final payment will constitute:
  - 1. a waiver of all Claims by Owner against Contractor, except Claims arising from unsettled Liens, from defective Work appearing after final inspection pursuant to Paragraph 14.06, from failure to comply with the Contract Documents or the terms of any special guarantees specified therein, or from Contractor's continuing obligations under the Contract Documents; and
  - 2. a waiver of all Claims by Contractor against Owner other than those previously made in accordance with the requirements herein and expressly acknowledged by Owner in writing as still unsettled.

**ARTICLE 15 - SUSPENSION OF WORK AND TERMINATION**

15.01 *Owner May Suspend Work*

- A. At any time and without cause, Owner may suspend the Work or any portion thereof for a period of not more than 90 consecutive days by notice in writing to Contractor and Engineer which will fix the date on which Work will be resumed. Contractor shall resume the Work on the date so fixed. Contractor shall be granted an adjustment in the Contract Price or an extension of the Contract Times, or both, directly attributable to any such suspension if Contractor makes a Claim therefor as provided in Paragraph 10.05.

15.02 *Owner May Terminate for Cause*

- A. The occurrence of any one or more of the following events will justify termination for cause:
  - 1. Contractor's persistent failure to perform the Work in accordance with the Contract Documents (including, but not limited to, failure to supply sufficient skilled workers or suitable materials or equipment or failure to adhere to the Progress Schedule established under Paragraph 2.07 as adjusted from time to time pursuant to Paragraph 6.04);
  - 2. Contractor's disregard of Laws or Regulations of any public body having jurisdiction;
  - 3. Contractor's disregard of the authority of Engineer; or
  - 4. Contractor's violation in any substantial way of any provisions of the Contract Documents.
- B. If one or more of the events identified in Paragraph 15.02.A occur, Owner may, after giving Contractor (and surety) seven days written notice of its intent to terminate the services of Contractor:
  - 1. exclude Contractor from the Site, and take possession of the Work and of all Contractor's tools, appliances, construction equipment, and machinery at the Site, and use the same to the full extent they could be used by Contractor (without liability to Contractor for trespass or conversion);
  - 2. incorporate in the Work all materials and equipment stored at the Site or for which Owner has paid Contractor but which are stored elsewhere; and

3. complete the Work as Owner may deem expedient.
- C. If Owner proceeds as provided in Paragraph 15.02.B, Contractor shall not be entitled to receive any further payment until the Work is completed. If the unpaid balance of the Contract Price exceeds all claims, costs, losses, and damages (including but not limited to all fees and charges of engineers, architects, attorneys, and other professionals and all court or arbitration or other dispute resolution costs) sustained by Owner arising out of or relating to completing the Work, such excess will be paid to Contractor. If such claims, costs, losses, and damages exceed such unpaid balance, Contractor shall pay the difference to Owner. Such claims, costs, losses, and damages incurred by Owner will be reviewed by Engineer as to their reasonableness and, when so approved by Engineer, incorporated in a Change Order. When exercising any rights or remedies under this Paragraph Owner shall not be required to obtain the lowest price for the Work performed.
  - D. Notwithstanding Paragraphs 15.02.B and 15.02.C, Contractor's services will not be terminated if Contractor begins within seven days of receipt of notice of intent to terminate to correct its failure to perform and proceeds diligently to cure such failure within no more than 30 days of receipt of said notice.
  - E. Where Contractor's services have been so terminated by Owner, the termination will not affect any rights or remedies of Owner against Contractor then existing or which may thereafter accrue. Any retention or payment of moneys due Contractor by Owner will not release Contractor from liability.
  - F. If and to the extent that Contractor has provided a performance bond under the provisions of Paragraph 5.01.A, the termination procedures of that bond shall supersede the provisions of Paragraphs 15.02.B, and 15.02.C.

15.03 *Owner May Terminate For Convenience*

- A. Upon seven days written notice to Contractor and Engineer, Owner may, without cause and without prejudice to any other right or remedy of Owner, terminate the Contract. In such case, Contractor shall be paid for (without duplication of any items):
  1. completed and acceptable Work executed in accordance with the Contract Documents prior to the effective date of termination, including fair and reasonable sums for overhead and profit on such Work;
  2. expenses sustained prior to the effective date of termination in performing services and furnishing labor, materials, or equipment as required by the Contract Documents in connection with uncompleted Work, plus fair and reasonable sums for overhead and profit on such expenses;
  3. all claims, costs, losses, and damages (including but not limited to all fees and charges of engineers, architects, attorneys, and other professionals and all court or arbitration or other dispute resolution costs) incurred in settlement of terminated contracts with Subcontractors, Suppliers, and others; and
  4. reasonable expenses directly attributable to termination.
- B. Contractor shall not be paid on account of loss of anticipated profits or revenue or other economic loss arising out of or resulting from such termination.

15.04 *Contractor May Stop Work or Terminate*

- A. If, through no act or fault of Contractor, (i) the Work is suspended for more than 90 consecutive days by Owner or under an order of court or other public authority, or (ii) Engineer fails to act on any Application for Payment within 30 days after it is submitted, or (iii) Owner fails for 30 days to pay Contractor any sum finally determined to be due, then Contractor may, upon seven days written notice to Owner and Engineer,

and provided Owner or Engineer do not remedy such suspension or failure within that time, terminate the Contract and recover from Owner payment on the same terms as provided in Paragraph 15.03.

- B. In lieu of terminating the Contract and without prejudice to any other right or remedy, if Engineer has failed to act on an Application for Payment within 30 days after it is submitted, or Owner has failed for 30 days to pay Contractor any sum finally determined to be due, Contractor may, seven days after written notice to Owner and Engineer, stop the Work until payment is made of all such amounts due Contractor, including interest thereon. The provisions of this Paragraph 15.04 are not intended to preclude Contractor from making a Claim under Paragraph 10.05 for an adjustment in Contract Price or Contract Times or otherwise for expenses or damage directly attributable to Contractor's stopping the Work as permitted by this Paragraph.

## **ARTICLE 16 - DISPUTE RESOLUTION**

### *16.01 Methods and Procedures*

- A. Dispute resolution methods and procedures, if any, shall be as set forth in the Supplementary Conditions. If no method and procedure has been set forth, and subject to the provisions of Paragraph 10.05, Owner and Contractor may exercise such rights or remedies as either may otherwise have under the Contract Documents or by Laws or Regulations in respect of any dispute.

## **ARTICLE 17 - MISCELLANEOUS**

### *17.01 Giving Notice*

- A. Whenever any provision of the Contract Documents requires the giving of written notice, it will be deemed to have been validly given if:
  - 1. delivered in person to the individual or to a member of the firm or to an officer of the corporation for whom it is intended, or
  - 2. delivered at or sent by registered or certified mail, postage prepaid, to the last business address known to the giver of the notice.

### *17.02 Computation of Times*

- A. When any period of time is referred to in the Contract Documents by days, it will be computed to exclude the first and include the last day of such period. If the last day of any such period falls on a Saturday or Sunday or on a day made a legal holiday by the law of the applicable jurisdiction, such day will be omitted from the computation.

### *17.03 Cumulative Remedies*

- A. The duties and obligations imposed by these General Conditions and the rights and remedies available hereunder to the parties hereto are in addition to, and are not to be construed in any way as a limitation of, any rights and remedies available to any or all of them which are otherwise imposed or available by Laws or Regulations, by special warranty or guarantee, or by other provisions of the Contract Documents. The provisions of this Paragraph will be as effective as if repeated specifically in the Contract Documents in connection with each particular duty, obligation, right, and remedy to which they apply.

### *17.04 Survival of Obligations*



- A. All representations, indemnifications, warranties, and guarantees made in, required by, or given in accordance with the Contract Documents, as well as all continuing obligations indicated in the Contract Documents, will survive final payment, completion, and acceptance of the Work or termination or completion of the Contract or termination of the services of Contractor.

17.05 *Controlling Law*

- A. This Contract is to be governed by the law of the state in which the Project is located.

17.06 *Headings*

- A. Article and paragraph headings are inserted for convenience only and do not constitute parts of these General Conditions.

++ END OF GENERAL CONDITIONS ++

**PAYMENT BOND**

Any singular reference to Contractor, Surety, Owner, or other party shall be considered plural where applicable.

CONTRACTOR (*Name and Address*):

SURETY (*Name, and Address of Principal Place of Business*):

OWNER (*Name and Address*):

Covina Irrigating Company  
146 East College Street  
Covina, CA 91723

**CONTRACT**

Effective Date of Agreement:  
Amount:  
Description (*Name and Location*):

**BOND**

Bond Number:  
Date (*Not earlier than Effective Date of Agreement*):  
Amount:  
Modifications to this Bond Form:

Surety and Contractor, intending to be legally bound hereby, subject to the terms set forth below, do each cause this Payment Bond to be duly executed by an authorized officer, agent, or representative.

**CONTRACTOR AS PRINCIPAL**

**SURETY**

\_\_\_\_\_  
Contractor's Name and Corporate Seal (Seal)

\_\_\_\_\_  
Surety's Name and Corporate Seal (Seal)

By: \_\_\_\_\_  
Signature

By: \_\_\_\_\_  
Signature (Attach Power of Attorney)

\_\_\_\_\_  
Print Name

\_\_\_\_\_  
Print Name

\_\_\_\_\_  
Title

\_\_\_\_\_  
Title

Attest: \_\_\_\_\_  
Signature

Attest: \_\_\_\_\_  
Signature

\_\_\_\_\_  
Title

\_\_\_\_\_  
Title

*Note: Provide execution by additional parties, such as joint venturers, if necessary.*

1. Contractor and Surety, jointly and severally, bind themselves, their heirs, executors, administrators, successors, and assigns to Owner to pay for labor, materials, and equipment furnished by Claimants for use in the performance of the Contract, which is incorporated herein by reference.
2. With respect to Owner, this obligation shall be null and void if Contractor:
  - 2.1 Promptly makes payment, directly or indirectly, for all sums due Claimants, and
  - 2.2 Defends, indemnifies, and holds harmless Owner from all claims, demands, liens, or suits alleging non-payment by Contractor by any person or entity who furnished labor, materials, or equipment for use in the performance of the Contract, provided Owner has promptly notified Contractor and Surety (at the addresses described in Paragraph 12) of any claims, demands, liens, or suits and tendered defense of such claims, demands, liens, or suits to Contractor and Surety, and provided there is no Owner Default.
3. With respect to Claimants, this obligation shall be null and void if Contractor promptly makes payment, directly or indirectly, for all sums due.
4. Surety shall have no obligation to Claimants under this Bond until:
  - 4.1 Claimants who are employed by or have a direct contract with Contractor have given notice to Surety (at the address described in Paragraph 12) and sent a copy, or notice thereof, to Owner, stating that a claim is being made under this Bond and, with substantial accuracy, the amount of the claim.
  - 4.2 Claimants who do not have a direct contract with Contractor:
    1. Have furnished written notice to Contractor and sent a copy, or notice thereof, to Owner, within 90 days after having last performed labor or last furnished materials or equipment included in the claim stating, with substantial accuracy, the amount of the claim and the name of the party to whom the materials or equipment were furnished or supplied, or for whom the labor was done or performed; and
    2. Have either received a rejection in whole or in part from Contractor, or not received within 30 days of furnishing the above notice any communication from Contractor by which Contractor had indicated the claim will be paid directly or indirectly; and
    3. Not having been paid within the above 30 days, have sent a written notice to Surety (at the address described in Paragraph 12) and sent a copy, or notice thereof, to Owner, stating that a claim is being made under this Bond and enclosing a copy of the previous written notice furnished to Contractor.
5. If a notice by a Claimant required by Paragraph 4 is provided by Owner to Contractor or to Surety, that is sufficient compliance.
6. (Not Used.)
7. Surety's total obligation shall not exceed the amount of this Bond, and the amount of this Bond shall be credited for any payments made in good faith by Surety.
8. Amounts owed by Owner to Contractor under the Contract shall be used for the performance of the Contract and to satisfy claims, if any, under any performance bond. By Contractor furnishing and Owner accepting this Bond, they agree that all funds earned by Contractor in the performance of the Contract are dedicated to satisfy obligations of Contractor and Surety under this Bond, subject to Owner's priority to use the funds for the completion of the Work.
9. Surety shall not be liable to Owner, Claimants, or others for obligations of Contractor that are unrelated to the Contract. Owner shall not be liable for payment of any costs or expenses of any Claimant under this Bond, and shall have under this Bond no obligations to make payments to, give notices on behalf of, or otherwise have obligations to Claimants under this Bond.

10. Surety hereby waives notice of any change, including changes of time, to the Contract or to related subcontracts, purchase orders, and other obligations.

11. No suit or action shall be commenced by a Claimant under this Bond other than in a court of competent jurisdiction in the location in which the Work or part of the Work is located or after the expiration of one year from the date (1) on which the Claimant gave the notice required by Paragraph 4.1 or Paragraph 4.2.3, or (2) on which the last labor or service was performed by anyone or the last materials or equipment were furnished by anyone under the Contract, whichever of (1) or (2) first occurs. If the provisions of this paragraph are void or prohibited by law, the minimum period of limitation available to sureties as a defense in the jurisdiction of the suit shall be applicable.

12. Notice to Surety, Owner, or Contractor shall be mailed or delivered to the addresses shown on the signature page. Actual receipt of notice by Surety, Owner, or Contractor, however accomplished, shall be sufficient compliance as of the date received at the address shown on the signature page.

13. When this Bond has been furnished to comply with a statutory requirement in the location where the Contract was to be performed, any provision in this Bond conflicting with said statutory requirement shall be deemed deleted herefrom and provisions conforming to such statutory requirement shall be deemed incorporated herein. The intent is that this Bond shall be construed as a statutory Bond and not as a common law bond.

14. Upon request of any person or entity appearing to be a potential beneficiary of this Bond, Contractor shall promptly furnish a copy of this Bond or shall permit a copy to be made.

15. Definitions

15.1 Claimant: An individual or entity having a direct contract with Contractor, or with a first-tier subcontractor of Contractor, to furnish labor, materials, or equipment for use in the performance of the Contract. The intent of this Bond shall be to include without limitation in the terms “labor, materials or equipment” that part of water, gas, power, light, heat, oil, gasoline, telephone service, or rental equipment used in the Contract, architectural and engineering services required for performance of the Work of Contractor and Contractor’s subcontractors, and all other items for which a mechanic’s lien may be asserted in the jurisdiction where the labor, materials, or equipment were furnished.

15.2 Contract: The agreement between Owner and Contractor identified on the signature page, including all Contract Documents and changes thereto.

15.3 Owner Default: Failure of Owner, which has neither been remedied nor waived, to pay Contractor as required by the Contract, or to perform and complete or otherwise comply with the other terms thereof.

FOR INFORMATION ONLY – *(Name, Address, and Telephone)*

Surety Agency or Broker:

Owner’s Representative *(Engineer or other)*:

# PERFORMANCE BOND

Any singular reference to Contractor, Surety, Owner, or other party shall be considered plural where applicable.

CONTRACTOR (Name and Address):

SURETY (Name and Address of Principal Place of Business):

OWNER (Name and Address):

Covina Irrigating Company  
146 East College Street  
Covina, CA 91723

CONTRACT

Date:

Amount:

Description (Name and Location):

BOND

Bond Number:

Date (Not earlier than Contract Date):

Amount:

Modifications to this Bond Form:

Surety and Contractor, intending to be legally bound hereby, subject to the terms printed on the reverse side hereof, do each cause this Performance Bond to be duly executed on its behalf by its authorized officer, agent, or representative.

CONTRACTOR AS PRINCIPAL

Company:

Signature: \_\_\_\_\_ (Seal)

Name and Title:

SURETY

\_\_\_\_\_  
(Seal)

Surety's Name and Corporate Seal

By:

\_\_\_\_\_  
Signature and Title

(Attach Power of Attorney)

(Space is provided below for signatures of additional parties, if required.)

Attest:

\_\_\_\_\_  
Signature and Title

CONTRACTOR AS PRINCIPAL

Company:

Signature: \_\_\_\_\_ (Seal)

Name and Title:

SURETY

\_\_\_\_\_  
(Seal)

Surety's Name and Corporate Seal

By:

\_\_\_\_\_  
Signature and Title

(Attach Power of Attorney)

Attest:

\_\_\_\_\_  
Signature and Title:

EJCDC No. C-610 (2002 Edition)

Originally prepared through the joint efforts of the Surety Association of America, Engineers Joint Contract Documents Committee, the Associated General Contractors of America, and the American Institute of Architects.

1. Contractor and Surety, jointly and severally, bind themselves, their heirs, executors, administrators, successors, and assigns to Owner for the performance of the Contract, which is incorporated herein by reference.

2. If Contractor performs the Contract, Surety and Contractor have no obligation under this Bond, except to participate in conferences as provided in Paragraph 3.1.

3. If there is no Owner Default, Surety's obligation under this Bond shall arise after:

3.1. Owner has notified Contractor and Surety, at the addresses described in Paragraph 10 below, that Owner is considering declaring a Contractor Default and has requested and attempted to arrange a conference with Contractor and Surety to be held not later than 15 days after receipt of such notice to discuss methods of performing the Contract. If Owner, Contractor and Surety agree, Contractor shall be allowed a reasonable time to perform the Contract, but such an agreement shall not waive Owner's right, if any, subsequently to declare a Contractor Default; and

3.2. Owner has declared a Contractor Default and formally terminated Contractor's right to complete the Contract. Such Contractor Default shall not be declared earlier than 20 days after Contractor and Surety have received notice as provided in Paragraph 3.1; and

3.3. Owner has agreed to pay the Balance of the Contract Price to:

1. Surety in accordance with the terms of the Contract;
2. Another contractor selected pursuant to Paragraph 4.3 to perform the Contract.

4. When Owner has satisfied the conditions of Paragraph 3, Surety shall promptly and at Surety's expense take one of the following actions:

4.1. Arrange for Contractor, with consent of Owner, to perform and complete the Contract; or

4.2. Undertake to perform and complete the Contract itself, through its agents or through independent contractors; or

4.3. Obtain bids or negotiated proposals from qualified contractors acceptable to Owner for a contract for performance and completion of the Contract, arrange for a contract to be prepared for execution by Owner and Contractor selected with Owner's concurrence, to be secured with performance and payment bonds executed by a qualified surety equivalent to the bonds issued on the Contract, and pay to Owner the amount of damages as described in Paragraph 6 in excess of the Balance of the Contract Price incurred by Owner resulting from Contractor Default; or

4.4. Waive its right to perform and complete, arrange for completion, or obtain a new contractor and with reasonable promptness under the circumstances:

1. After investigation, determine the amount for which it may be liable to Owner and, as soon as practicable after the amount is determined, tender payment therefor to Owner; or
2. Deny liability in whole or in part and notify Owner citing reasons therefor.

5. If Surety does not proceed as provided in Paragraph 4 with reasonable promptness, Surety shall be deemed to be in default on this Bond 15 days after receipt of an additional written notice from Owner to Surety demanding that Surety perform its obligations under this Bond, and Owner shall be entitled to enforce any remedy available to Owner. If Surety proceeds as provided in Paragraph 4.4, and Owner refuses the payment tendered or Surety has denied liability, in whole or in part, without further notice Owner shall be entitled to enforce any remedy available to Owner.

6. After Owner has terminated Contractor's right to complete the Contract, and if Surety elects to act under Paragraph 4.1, 4.2, or 4.3 above, then the responsibilities of Surety to Owner shall not be greater than those of Contractor under the Contract, and the responsibilities of Owner to Surety shall not be greater than those of Owner under the Contract. To a limit of the amount of this Bond, but subject to commitment by Owner of the Balance of the Contract Price to mitigation of costs and damages on the Contract, Surety is obligated without duplication for:

6.1. The responsibilities of Contractor for correction of defective Work and completion of the Contract;

6.2. Additional legal, design professional, and delay costs resulting from Contractor's Default, and resulting from the actions or failure to act of Surety under Paragraph 4; and

6.3. Liquidated damages, or if no liquidated damages are specified in the Contract, actual damages caused by delayed performance or non-performance of Contractor.

7. Surety shall not be liable to Owner or others for obligations of Contractor that are unrelated to the Contract, and the Balance of the Contract Price shall not be reduced or set off on account of any such unrelated obligations. No right of action shall accrue on this Bond to any person or entity other than Owner or its heirs, executors, administrators, or successors.

8. Surety hereby waives notice of any change, including changes of time, to Contract or to related subcontracts, purchase orders, and other obligations.

9. Any proceeding, legal or equitable, under this Bond may be instituted in any court of competent jurisdiction in the location in which the Work or part of the Work is located and shall be instituted within two years after Contractor Default or within two years after Contractor ceased working or within two years after Surety refuses or fails to perform its obligations under this Bond, whichever occurs first. If the provisions of this paragraph are void or prohibited by law, the minimum period of limitation available to sureties as a defense in the jurisdiction of the suit shall be applicable.

10. Notice to Surety, Owner, or Contractor shall be mailed or delivered to the address shown on the signature page.

11. When this Bond has been furnished to comply with a statutory requirement in the location where the Contract was to be performed, any provision in this Bond conflicting with said statutory requirement shall be deemed deleted herefrom and provisions conforming to such statutory requirement shall be deemed incorporated herein. The intent is that this Bond shall be construed as a statutory bond and not as a common law bond.

12. Definitions.

12.1 Balance of the Contract Price: The total amount payable by Owner to Contractor under the Contract after all proper adjustments have been made, including allowance to Contractor of any amounts received or to be received by Owner in settlement of insurance or other Claims for damages to which Contractor is entitled, reduced by all valid and proper payments made to or on behalf of Contractor under the Contract.

12.2 Contract: The agreement between Owner and Contractor identified on the signature page, including all Contract Documents and changes thereto.

12.3 Contractor Default: Failure of Contractor, which has neither been remedied nor waived, to perform or otherwise to comply with the terms of the Contract.

12.4 Owner Default: Failure of Owner, which has neither been remedied nor waived, to pay Contractor as required by the Contract or to perform and complete or comply with the other terms thereof.

FOR INFORMATION ONLY – Name, Address and Telephone  
Surety Agency or Broker  
Owner's Representative (engineer or other party)

**COVINA IRRIGATING COMPANY  
UV/CHLORAMINES PROJECT  
TEMPLE WATER TREATMENT PLANT  
GLEN DORA, CA**

AGREEMENT

THIS AGREEMENT is dated as of the \_\_\_\_\_ day of \_\_\_\_\_ in the year \_\_\_\_\_, by and between the Covina Irrigating Company, 146 East College Street, Covina, CA (hereinafter called Owner) and

\_\_\_\_\_  
(hereinafter called Contractor).

WITNESSETH: Owner and Contractor, in consideration of the mutual covenants hereinafter set forth, agree as follows:

ARTICLE 1 - WORK

1.01 Contractor shall at its own cost and expense furnish all labor, services, tools, materials, equipment and incidentals necessary to complete all Work as specified or indicated in the Contract Documents to construct the UV/Chloramines at the Temple Water Treatment Plant. The Work is generally described in Section 01110 of the General Requirements.

ARTICLE 2 - PROJECT

2.01 The Project for which the Work under the Contract Documents may be the whole or only a part is generally described as follows:

UV facility, pump station, and chemical feed facilities.

ARTICLE 3 - ENGINEER

3.01 The Project has been designed by Malcolm Pirnie Inc., who is hereinafter called Engineer and who is to act as Owner's representative, assume all duties and responsibilities and have the rights and authority assigned to Engineer in the Contract Documents in connection with completion of the Work in accordance with the Contract Documents.

ARTICLE 4 - CONTRACT TIMES

4.01 Time is of the Essence

- A. All time limits for Milestones, if any, Substantial Completion and completion and readiness for final payment as stated in the Contract Documents are of the essence of the Contract.

#### 4.02 Days to Achieve Substantial Completion and Final Payment

- A. The Work will be substantially completed within 520 days after the date when the Contract Times commence to run as provided in Paragraph 2.03 of the General Conditions, and completed and ready for final payment in accordance with Paragraph 14.07 of the General Conditions within 580 days from the date when the Contract Times commence to run.

#### 4.03 Liquidated Damages

- A. Owner and Contractor recognize that time is of the essence of this Agreement and Owner will suffer financial loss, apart from the costs described in Paragraph 4.04.A, if the Work is not substantially completed within the time specified in Paragraph 4.02.A for Substantial Completion, plus any extensions thereof allowed in accordance with Article 12 of the General Conditions. Owner and Contractor also recognize the delays, expense and difficulties involved in proving in a legal or arbitration proceeding the actual loss suffered by Owner if the Work is not substantially completed on time. Accordingly, instead of requiring any such proof, Owner and Contractor agree that as liquidated damages for delay (but not as a penalty) Contractor shall pay Owner \$1,200 for each day that expires after the time specified in Paragraph 4.02.A for Substantial Completion (adjusted for any changes thereof made in accordance with Article 12 of the General Conditions) until the Work is substantially complete.

#### 4.04 Special Damages

- A. In addition to the amount provided for liquidated damages, Contractor shall pay OWNER \$10,000 for each day, beyond the allowable number of shutdown days specified in Section 01143, that the Temple Water Treatment Plant is not able to produce potable water at its current full capacity due to construction activities. This loss of production cost shall be incurred regardless of schedule or project status.
- B. In addition to the amount provided for liquidated damages, Contractor shall pay OWNER the actual costs reasonably incurred by Owner for engineering and inspection forces employed for the Work for each day that expires after the days specified in Paragraph. 4.02.A for Substantial Completion (adjusted for any changes thereof made in accordance with Article 12 of the General Conditions) until the Work is substantially complete.
- C. After Substantial Completion, if Contractor shall neglect, refuse or fail to complete the remaining Work within the Contract Time or any proper extension



thereof granted by Owner, Contractor shall pay Owner the actual costs reasonably incurred by Owner for engineering and inspection forces employed for the Work for each day that expires after the time specified in Article 3 for Work to be completed and ready for final payment (adjusted for any extensions thereof made in accordance with Article 12 of the General Conditions) until the Work is completed and ready for final payment.

- 4.05 Owner may deduct liquidated damages and special damages as determined by the provisions of this Article 4 from progress payments due Contractor under this Agreement.

#### ARTICLE 5 - CONTRACT PRICE

- 5.01 Owner shall pay Contractor, in current funds, for completion of the Work in accordance with the Contract Documents the prices stated in Contractor's Bid, which Bid is attached hereto and identified as Exhibit 1 of this Agreement. As provided in Paragraph 11.03 of the General Conditions, estimated quantities are not guaranteed, and determinations of actual quantities and classifications are to be made by Engineer as provided in Paragraph 9.07 of the General Conditions. Unit prices have been computed as provided in Paragraph 11.03 of the General Conditions.

#### ARTICLE 6 - PAYMENT PROCEDURES

##### 6.01 Submittal and Processing of Payments

- A. Contractor shall submit Applications for Payment in accordance with Article 14 of the General Conditions. Applications for Payment will be processed as provided in the General Conditions.

##### 6.02 Progress Payments; Retainage

- A. Owner shall make monthly progress payments on account of the Contract Price on the basis of Contractor's Applications for Payment as recommended by Engineer. Contractor's Applications for Payment will be due on the 28th day of the month. All progress payments will be on the basis of the progress of the Work measured by the schedule of values provided for in Paragraph 2.07.A of the General Conditions (and in the case of Unit Price Work, based on the number of units completed) or, in the event there is no schedule of values, as provided in the General Requirements. A progress payment will not be made whenever the value of the Work completed since the last previous progress payment is less than \$5,000.

1. Prior to Substantial Completion

- a. Progress payments will be made in the amount of 90 percent of the Work completed, (with the balance being retainage), less the aggregate of payments previously made and less such amounts as Engineer shall determine, or Owner may withhold, in accordance with Paragraph 14.02 of the General Conditions; and
  - b. 90 percent of the cost of materials and equipment not incorporated in the Work but suitably stored (with the balance being retainage).
2. Upon Substantial Completion, Owner shall pay an amount sufficient to increase total payments to Contractor to 100 percent of the Work completed, less such amounts as Engineer shall determine in accordance with Paragraph 14.02.B.5 of the General Conditions and less 200 percent of Engineer's estimate of the value of Work to be completed or corrected as shown on the tentative list of items to be completed or corrected attached to the certificate of Substantial Completion.

6.03 Final Payment:

- A. Upon final completion and acceptance of the Work in accordance with Paragraph 14.07 of the General Conditions, Owner shall pay the remainder of the Contract Price as recommended by Engineer as provided in said Paragraph 14.07.

ARTICLE 7 - INTEREST

- 7.01 All moneys not paid when due hereunder shall bear interest at the maximum rate allowed by law at the place of the Project.

ARTICLE 8 - CONTRACTOR'S REPRESENTATIONS

- 8.01 As part of the inducement for Owner to enter into this Agreement Contractor makes the following representations:
- A. Contractor has examined and carefully studied the Contract Documents and the other related data identified in the Bidding Documents.
  - B. Contractor has visited the Site and become familiar with and is satisfied as to the general, local and Site conditions that may affect cost, progress, and performance of the Work.
  - C. Contractor is familiar with and is satisfied as to all federal, state and local Laws and Regulations that may affect cost, progress and performance of the Work.
  - D. Contractor has carefully studied all reports of explorations and tests of subsurface conditions at or contiguous to the Site and all drawings of physical conditions in

or relating to existing surface or subsurface structures at or contiguous to the Site (except Underground Facilities) which have been identified in the Supplementary Conditions as provided in Paragraph 4.02 of the General Conditions.

- E. Contractor does not consider that any further examinations, investigations, explorations, tests, studies or data are necessary for the performance of the Work at the Contract Price, within the Contract Times and in accordance with the other terms and conditions of the Contract Documents.
- F. Contractor is aware of the general nature of work to be performed by Owner and others at the Site that relates to the Work as indicated in the Contract Documents.
- G. Contractor has correlated the information known to Contractor, information and observations obtained from visits to the Site, reports and drawings identified in the Contract Documents and all additional examinations, investigations, explorations, tests, studies and data with the Contract Documents.
- H. Contractor has given Engineer written notice of all conflicts, errors, ambiguities, or discrepancies that Contractor has discovered in the Contract Documents and the written resolution thereof by Engineer is acceptable to Contractor.
- I. The Contract Documents are generally sufficient to indicate and convey understanding of all terms and conditions for the performance of the Work.

## ARTICLE 9 - CONTRACT DOCUMENTS

9.01 The Contract Documents consist of the following:

- A. This Agreement (\_\_\_\_\_ pages).
- B. Performance Bond (\_\_\_\_\_ pages).
- C. Payment Bond (\_\_\_\_\_ pages).
- D. General Conditions (\_\_\_\_\_ pages).
- E. Supplementary Conditions (\_\_\_\_\_ pages).
- F. Specifications, as listed in the table of contents of the Project Manual.
- H. The Drawings comprising a set entitled UV/Chloramines for Temple Water Treatment Plant, dated October 2009, and including the following:

Title Sheet  
Index Sheet  
Sheets numbered C-1 through I-9, inclusive

- I. Addenda consisting of Numbers\_\_\_\_ to \_\_\_\_\_, inclusive.
  - J. Exhibits to the Agreement enumerated as follows:
    - 1. Exhibit 1, Contractor's Bid (\_\_\_\_\_ pages).
  - K. The following, which may be delivered or issued on or after the Effective Date of the Agreement, and are not attached hereto:
    - 1. Notice to Proceed
    - 2. Work Change Directives
    - 3. Change Order(s)
- 9.02 The documents listed in Paragraph 9.01 above are attached to this Agreement (except as expressly noted otherwise above). Documents not attached are incorporated by reference. There are no Contract Documents other than those listed in this Article 9.
- 9.03 The Contract Documents may only be amended or supplemented as provided in Paragraph 3.04 of the General Conditions.

## ARTICLE 10 - MISCELLANEOUS

### 10.01 Terms

- A. Terms used in this Agreement will have the meanings indicated in the General Conditions and the Supplementary Conditions.

### 10.02 Assignment of Contract

- A. No assignment by a party hereto of any rights under or interests in the Contract will be binding on another party hereto without the written consent of the party sought to be bound; and, specifically but without limitation, moneys that may become due and moneys that are due may not be assigned without such consent (except to the extent that the effect of this restriction may be limited by law), and unless specifically stated to the contrary in any written consent to an assignment, no assignment will release or discharge the assignor from any duty or responsibility under the Contract Documents.

### 10.03 Successors and Assigns

- A. Owner and Contractor each binds itself, its partners, successors, assigns and legal representatives to the other party hereto, its partners, successors, assigns and legal

representatives in respect to all covenants, agreements and obligations contained in the Contract Documents.

#### 10.04 Severability

- A. Any provision or part of the Contract Documents, held to be void or unenforceable under any Law or Regulation shall be deemed stricken, and all remaining provisions shall continue to be valid and binding upon Owner and Contractor, who agree that the Contract Documents shall be reformed to replace such stricken provision or part thereof with a valid and enforceable provision that comes as close as possible to expressing the intention of the stricken provision.

#### 10.05 Waiver

- A. The waiver by the Owner of any breach or violation of any term, covenant, or condition of this Agreement or of any Law or Regulation shall not be deemed to be a waiver of any other term, covenant, condition, or Law or Regulation or of any subsequent breach or violation of the same or of any other term, covenant, condition, or Law or Regulation. The subsequent payment of any monies or fee by the Owner which may become due hereunder shall not be deemed to be a waiver of any preceding breach or violation by Contractor of any term, covenant, condition of this Agreement or of any applicable Law or Regulation.

IN WITNESS WHEREOF, Owner and Contractor have signed this Agreement on the day and year first written above.

This Agreement will be effective on \_\_\_\_\_, 20\_\_\_\_ (which is the Effective Date of the Agreement).

Owner: Covina Irrigating Company Contractor: \_\_\_\_\_

By: \_\_\_\_\_ By: \_\_\_\_\_

David D. De Jesus

Title: President Title: \_\_\_\_\_

[CORPORATE SEAL]

[CORPORATE SEAL]

Attest \_\_\_\_\_

Attest \_\_\_\_\_

Title: \_\_\_\_\_

Title: \_\_\_\_\_

Address for giving notices

Address for giving notices

146 E. College St.

\_\_\_\_\_

Covina, CA 91723

\_\_\_\_\_

(If Owner is a corporation, partnership, or limited liability company, attach evidence of authority to sign) (If Owner is a public body, attach evidence of authority to sign and resolution or other documents authorizing execution of Agreement.)

License No. \_\_\_\_\_  
(where applicable)

Agent for service of process: \_\_\_\_\_

\_\_\_\_\_

(If Contractor is a corporation, partnership, or limited liability company, attach evidence of authority to sign.)

Designated Representative:

Name: \_\_\_\_\_

Title: \_\_\_\_\_

Address: \_\_\_\_\_

Phone No.: \_\_\_\_\_

Fax No.: \_\_\_\_\_

Designated Representative:

Name: \_\_\_\_\_

Title: \_\_\_\_\_

Address: \_\_\_\_\_

Phone No.: \_\_\_\_\_

Fax No.: \_\_\_\_\_

++END OF AGREEMENT++

**BID BOND**  
(Damages Form)

Any singular reference to Bidder, Surety, Owner or other party shall be  
considered plural where applicable

---

**BIDDER (Name and Address):**

\_\_\_\_\_  
\_\_\_\_\_  
\_\_\_\_\_

**SURETY (Name and Address of Principal Place of Business):**

\_\_\_\_\_  
\_\_\_\_\_  
\_\_\_\_\_

**OWNER:**

Covina Irrigating Company  
146 East College Street  
Covina, CA 91723

**BID**

Bid Due Date: \_\_\_\_\_

Project:  
UV/Chloramines at Temple Water Treatment Plant



**BOND**

Bond Number: \_\_\_\_\_

Date: (Not later than Bid due date): \_\_\_\_\_

Penal Sum: \_\_\_\_\_

(Words)

(Figures)

Surety and Bidder, intending to be legally bound hereby, subject to the terms printed on the reverse side hereof, do each cause this Bid Bond to be duly executed on its behalf by its authorized officer, agent, or representative.

**BIDDER**

**SURETY**

\_\_\_\_\_(Seal)

Bidder's Name and Corporate Seal

\_\_\_\_\_(Seal)

Surety's Name and Corporate Seal

By: \_\_\_\_\_

Signature and Title

By: \_\_\_\_\_

Signature and Title

(Attach Power of Attorney)

Attest: \_\_\_\_\_

Signature and Title

Attest: \_\_\_\_\_

Signature and Title

---

Notes: (1) Above addresses are to be used for giving required notice.

(2) Adapted from EJCDC No. C-435 (2002 Edition).

1.0 Bidder and Surety, jointly and severally, bind themselves, their heirs, executors, administrators, successors and assigns to pay to Owner upon default of Bidder any difference between the total amount of Bidder's Bid and the total amount of the Bid of the next lowest, responsible Bidder who submitted a responsive Bid as determined by Owner for the Work required by the Bidding Documents, provided that:

1.1 If there is no such next Bidder, and Owner does not abandon the Project, then Bidder and Surety shall pay to Owner the penal sum set forth on the face of this Bond, and

1.2 In no event shall Bidder's and Surety's obligation hereunder exceed the penal sum set forth on the face of this Bond.

2.0 Default of Bidder shall occur upon the failure of Bidder to deliver within the time required by the Bidding Documents (or any extension thereof agreed to in writing by Owner) the executed Agreement required by the Bidding Documents and any performance and payment bonds required by the Bidding Documents.

3.0 This obligation shall be null and void if:

3.1 Owner accepts Bidder's Bid and Bidder delivers within the time required by the Bidding Documents (or any extension thereof agreed to in writing by Owner) the executed Agreement required by the Bidding Documents and any performance and payment Bonds required by the Bidding Documents, or

3.2 All Bids are rejected by Owner, or

3.3 Owner fails to issue a Notice of Award to Bidder within the time specified in the Bidding Documents (or any extension thereof agreed to in writing by Bidder and, if applicable, consented to by Surety when required by Paragraph 5.0 hereof).

4.0 Payment under this Bond will be due and payable upon default by Bidder and within 30 calendar days after receipt by Bidder and Surety of written notice of default from Owner, which notice will be given with reasonable promptness, identifying this Bond and the Project and including a statement of the amount due.

5.0 Surety waives notice of and any and all defenses based on or arising out of any time extension to issue Notice of Award agreed to in writing by Owner and Bidder, provided that the total time for issuing Notice of Award including extensions shall not in the aggregate exceed 120 days from Bid due date without Surety's written consent.

6.0 No suit or action shall be commenced under this Bond prior to 30 calendar days after the notice of default required in Paragraph 4.0 above is received by Bidder and Surety and in no case later than one year after Bid due date.

7.0 Any suit or action under this Bond shall be commenced only in a court of competent jurisdiction located in the state in which the Project is located.

8.0 Notices required hereunder shall be in writing and sent to Bidder and Surety at their respective addresses shown on the face of this Bond. Such notices may be sent by personal delivery, commercial courier or by United States Registered or Certified Mail, return receipt requested, postage pre-paid, and shall be deemed to be effective upon receipt by the party concerned.

9.0 Surety shall cause to be attached to this Bond a current and effective Power or Attorney evidencing the authority of the officer, agent or representative who executed this Bond on behalf of Surety to execute, seal and deliver such Bond and bind the Surety thereby.

10.0 This Bond is intended to conform to all applicable statutory requirements. Any applicable requirement of any applicable statute that has been omitted from this Bond shall be deemed to be included herein as if set forth at length. If any provision of this Bond conflicts with any applicable statute, then the provision of said statute shall govern and the remainder of this Bond that is not in conflict therewith shall continue in full force and effect.

11.0 The term "Bid" as used herein includes a Bid, offer or proposal as applicable.

++END OF BID BOND++



BID FORM

COVINA IRRIGATING COMPANY

UV/CHLORAMINES AT TEMPLE WATER TREATMENT PLANT

TABLE OF ARTICLES

1. Bid Recipient
2. Bidder's Acknowledgements
3. Bidder's Representations
4. Basis of Bid
5. Time of Completion
6. Attachments to this Bid
7. Defined Terms
8. Bid Submittal

ARTICLE 1 - BID RECIPIENT

1.01 This Bid is submitted to:

Covina Irrigating Company  
146 East College Street  
Covina, CA 91723

1.02 The undersigned Bidder proposes and agrees, if this Bid is accepted, to enter into an Agreement with Owner in the form included in the Bidding Documents to perform all Work as specified or indicated in the Bidding Documents for the price(s) and within the times indicated in this Bid and in accordance with the Bidding Documents.

ARTICLE 2 - BIDDER’S ACKNOWLEDGEMENTS

2.01 Bidder accepts all of the terms and conditions of the Advertisement or Invitation to Bid and Instructions to Bidders, including without limitation those dealing with the disposition of Bid security. This Bid will remain subject to acceptance for sixty (60) days after the Bid opening, or for such longer period of time that Bidder may agree to in writing upon request of Owner. Bidder will sign the Agreement and will furnish the required contract security, and other required documents within the time periods set forth in the Bidding Documents.

ARTICLE 3 - BIDDER’S REPRESENTATIONS

3.01 In submitting this Bid, Bidder represents that:

A. Bidder has examined and carefully studied the Bidding Documents, the other related data identified in the Bidding Documents, if any, and the following Addenda, receipt of all of which is hereby acknowledged.

Addendum No.	Date Received	Addendum No.	Date Received
_____	_____	_____	_____
_____	_____	_____	_____
_____	_____	_____	_____

B. Bidder has visited the Site and become familiar with and is satisfied as to the general, local and Site conditions that may affect cost, progress, and performance of the Work.

- C. Bidder is familiar with and is satisfied as to all federal, state and local Laws and Regulations that may affect cost, progress and performance of the Work.
- D. Bidder has carefully studied all reports of explorations and tests of subsurface conditions at or contiguous to the Site and all drawings of physical conditions in or relating to existing surface or subsurface structures at or contiguous to the Site (except Underground Facilities) which have been identified in the Supplementary Conditions as provided in Paragraph 4.02 of the General Conditions.
- E. Bidder does not consider that any further examinations, investigations, explorations, tests, studies or data are necessary for the determination of this Bid for performance of the Work at the price(s) bid and within the times and in accordance with the other terms and conditions of the Bidding Documents.
- F. Bidder is aware of the general nature of work (if any) to be performed by Owner and others at the Site that relates to the Work as indicated in the Bidding Documents.
- G. Bidder has correlated the information known to Bidder, information and observations obtained from visits to the Site, reports and drawings identified in the Bidding Documents, and all additional examinations, investigations, explorations, tests, studies and data with the Bidding Documents.
- H. Bidder has given Engineer written notice of all conflicts, errors, ambiguities, or discrepancies that Bidder has discovered in the Bidding Documents, and the written resolution thereof by Engineer is acceptable to Bidder.
- I. The Bidding Documents are generally sufficient to indicate and convey understanding of all terms and conditions for the performance of the Work for which this Bid is submitted.

3.02 Bidder further represents that:

- A. This Bid is genuine and is not made in the interest of or on behalf of any undisclosed individual or entity and is not submitted in conformity with any agreement or rules of any group, association, organization or corporation;
- B. Bidder has not directly or indirectly induced or solicited any other Bidder to submit a false or sham Bid; Bidder has not solicited or induced any individual or entity to refrain from bidding;
- C. Bidder has not sought by collusion to obtain for itself any advantage over any other Bidder or over Owner; and
- D. No person or persons acting in any official capacity for the Owner are directly or indirectly interested in this Bid, or in any portion of the profit thereof.

ARTICLE 4 - BASIS OF BID

4.01 Bidder will complete the Work in accordance with the Contract Documents for the following price(s):

Description	Estimated Quantities	Unit Price	Bid Price
(Amounts to be shown in both words and numerals.)			
Item 1 – General Construction (All Work except items 2-5)	LS	---	\$
Item 2 – UV Equipment	LS	---	\$ 599,217
Item 3 – Site Paving	12,000 SF	\$	\$
Item 4 – Site Security Fencing and Gates	1,030 SF	\$	\$
Item 5 – Suburban Water Systems Facilities	LS	---	\$
<b>TOTAL OF ALL BID PRICES</b>			\$

Unit prices have been computed in accordance with Paragraph 11.03.B of the General Conditions.

Bidder acknowledges that estimated quantities of items of Unit Price Work are not guaranteed and are solely for the purpose of comparison of Bids, and final payment for all Unit Price items will be based on actual quantities of Unit Price Work, determined as provided in the Contract Documents.

All specified cash allowances are included in the price(s) set forth above and have been computed in accordance with Paragraph 11.02 of the General Conditions.

## ARTICLE 5 - TIME OF COMPLETION

- 5.01 Bidder agrees that the Work will be substantially complete and completed and ready for final payment in accordance with Paragraph 14.07.B of the General Conditions on or before the dates or within the number of calendar days indicated in the Agreement.
- 5.02 Bidder accepts the provisions of the Agreement as to liquidated and special damages in the event of failure to complete the Work within the Contract Times.

## ARTICLE 6 - ATTACHMENTS TO THIS BID

- 6.01 The following documents are attached to and made a condition of this Bid:
- A. Required Bid security in the form of \_\_\_\_\_.
  - B. Required Bidder Qualifications Statement with supporting data.
  - C. A tabulation of Subcontractors, Suppliers and other individuals and entities required to be identified in this Bid.

## ARTICLE 7 - DEFINED TERMS

- 7.01 The terms used in this Bid with initial capital letters have the meanings stated in the Instructions to Bidders and the General Conditions and Supplementary Conditions.

## ARTICLE 8 - BID SUBMITTAL

- 8.01 This Bid submitted on \_\_\_\_\_, 20\_\_ by:



If Bidder is:

An Individual

Name (Typed or Printed): \_\_\_\_\_

By \_\_\_\_\_  
(Individual's Signature)

Doing business as \_\_\_\_\_

License or Registration Number: \_\_\_\_\_

Business Address: \_\_\_\_\_  
\_\_\_\_\_

Phone No.: \_\_\_\_\_ Facsimile: \_\_\_\_\_

A Partnership

Partnership Name: \_\_\_\_\_

By: \_\_\_\_\_  
(Signature of General Partner - Attach evidence of authority to sign)

(Name (Typed or Printed): \_\_\_\_\_

License or Registration Number: \_\_\_\_\_

Business Address: \_\_\_\_\_  
\_\_\_\_\_

Phone No.: \_\_\_\_\_ Facsimile: \_\_\_\_\_

A Corporation

Corporation Name: \_\_\_\_\_

\_\_\_\_\_  
(State of Incorporation)

By \_\_\_\_\_

(Signature - Attach evidence of authority to sign)

Name and Title (Typed or Printed): \_\_\_\_\_

(CORPORATE  
SEAL)

Attest: \_\_\_\_\_

(Secretary)

License or Registration Number: \_\_\_\_\_

Business Address: \_\_\_\_\_

\_\_\_\_\_

Phone No.: \_\_\_\_\_ Facsimile: \_\_\_\_\_

Limited Liability Company

By: \_\_\_\_\_

(Firm Name)

\_\_\_\_\_  
(State of Formation)

By: \_\_\_\_\_

(Signature of Member/Authorized to Sign)

\_\_\_\_\_  
(Printed or Typed Name and Title of Member Authorized to Sign)  
(Attach evidence of authority to sign.)

License or Registration Number: \_\_\_\_\_

Business Address: \_\_\_\_\_

\_\_\_\_\_

Phone No.: \_\_\_\_\_ Facsimile: \_\_\_\_\_

A Joint Venture

Name of Joint Venture: \_\_\_\_\_

First Joint Venturer Name: \_\_\_\_\_

By: \_\_\_\_\_  
(Signature of First Joint Venturer - Attach evidence of authority to sign)

Name (Typed or Printed): \_\_\_\_\_  
(Title)

Title: \_\_\_\_\_

Second Joint Venturer Name: \_\_\_\_\_

By: \_\_\_\_\_  
(Signature of Second Joint Venturer - Attach evidence of authority to sign)

Name (Typed or Printed): \_\_\_\_\_  
(Title)

(Each joint venturer must sign. The manner of signing for each individual, partnership, corporation or limited liability company that is a party to the joint venture shall be in the manner indicated above).

Business Address: \_\_\_\_\_

Phone and Fax number and address for receipt of communications to joint venture:

Phone: \_\_\_\_\_ Facsimile: \_\_\_\_\_

++ END OF BID FORM ++

**COVINA IRRIGATING COMPANY  
UV/CHLORAMINES PROJECT  
TEMPLE WATER TREATMENT PLANT  
GLENDORA, CA**

INSTRUCTIONS TO BIDDERS

TABLE OF ARTICLES

1. Defined Terms
2. Bids Received
3. Location and Description of Project
4. Copies of Bidding Documents
5. Qualifications of Bidders
6. Examination of Bidding Documents, Other Related Data and Site
7. Pre-Bid Conference
8. Site and Other Areas
9. Interpretations and Addenda
10. Bid Security
11. Contract Times
12. Liquidated and Special Damages
13. Substitute and "Or Equal" Items
14. Subcontractors, Suppliers and Others
15. Preparation of Bid
16. Basis of Bids; Comparison of Bids
17. Submittal of Bid
18. Modification or Withdrawal of Bid
19. Opening of Bids
20. Disqualification of Bidders
21. Bids to Remain Subject to Acceptance
22. Evaluation of Bids and Award of Contract
23. Contract Securities
24. Contractor's Insurance
25. Signing of Agreement
26. Notice to Proceed
27. Sales and Use Taxes
28. Additional Requirements

ARTICLE 1 - DEFINED TERMS

- 1.01 Terms used in these Instructions to Bidders have the meanings indicated in the General Conditions and Supplementary Conditions. Additional terms used in these Instructions to Bidders have the meanings indicated below which are applicable to both the singular and plural thereof.

1.02 Additional terms used in these Instructions to Bidders have the meanings indicated below which are applicable to both the singular and plural thereof.

- A. Issuing Office: The office from which the Bidding Documents are to be issued and where the bidding procedures are to be administered.

#### ARTICLE 2 - BIDS RECEIVED

2.01 Refer to Invitation to Bid for information on receipt of Bids.

#### ARTICLE 3 - LOCATION AND DESCRIPTION OF PROJECT

3.01 Refer to Section 01110 of the General Requirements for the location and description of the Project.

#### ARTICLE 4 - COPIES OF BIDDING DOCUMENTS

4.01 Refer to Invitation to Bid for information on location where Bidders may examine and/or obtain Bidding Documents.

4.02 Complete sets of Bidding Documents shall be used in preparing Bids; neither Owner nor Engineer assumes any responsibility for errors or misinterpretations resulting from the use of incomplete sets of Bidding Documents.

4.03 Owner and Engineer, in making copies of Bidding Documents available on the above terms, do so only for the purpose of obtaining Bids for the Work and do not confer a license or grant permission for any other use.

#### ARTICLE 5 - QUALIFICATIONS OF BIDDERS

5.01 Bidders shall be experienced in the kind of Work to be performed, shall have the necessary equipment therefor, and shall possess sufficient capital to properly execute the Work within the time allowed. Bids received from Bidders who have previously failed to complete work within the time required, or who have previously performed similar work in an unsatisfactory manner, may be rejected. A Bid may be rejected if Bidder cannot show that Bidder has the necessary ability, plant and equipment to commence the Work at the time prescribed and thereafter to prosecute and complete the Work at the rate or within the time specified. A Bid may be rejected if Bidder is already obligated for the performance of other work which would delay the commencement, prosecution or completion of the Work.

- 5.02 To demonstrate qualifications to perform the Work, Bidder shall complete and submit with its Bid a separate Bidder Qualifications Statement which will be furnished by Engineer. An example of the Bidder Qualifications Statement is bound in the Project Manual. Bidders may be asked to furnish additional data to demonstrate their qualifications.
- 5.03 Bidders shall be qualified to do business in the state where the Project is located or covenant to obtain such qualification prior to signing the Agreement.
- 5.04 Bids will be received only from contractors who are licensed or registered by the State of California.

ARTICLE 6 - EXAMINATION OF BIDDING DOCUMENTS, OTHER RELATED DATA AND SITE

6.01 Subsurface and Physical Conditions

A. The Supplementary Conditions identify:

1. Those reports of explorations and tests of subsurface conditions at or contiguous to the Site which have been utilized by Engineer in preparation of the Bidding Documents.
2. Those drawings of physical conditions in or relating to existing surface and subsurface structures (except Underground Facilities) which are at or contiguous to the Site that have been utilized by Engineer in preparation of the Bidding Documents.

B. Copies of the reports and drawings referenced in the Supplementary Conditions will be made available by Owner to any Bidder on request. Those reports and drawings are not part of the Contract Documents, but the "technical data" contained therein upon which Bidder is entitled to rely as provided in Paragraph 4.02 of the General Conditions, has been identified and established in Paragraph SC-4.02 of the Supplementary Conditions. Bidder is responsible for any interpretation or conclusion drawn from any "technical data" or any other data, interpretations, opinions or information contained in such reports or shown or indicated in such drawings.

6.02 Underground Facilities - Physical Conditions

A. Information and data shown or indicated in the Bidding Documents with respect to existing Underground Facilities at or contiguous to the Site is based upon information and data furnished to Owner and Engineer by owners of such Underground Facilities, including Owner, or others.

6.03 Hazardous Environmental Condition

- A. Owner has no actual knowledge of a Hazardous Environmental Condition at the Site.
- 6.04 Provisions concerning responsibilities for the adequacy of data, if any, furnished to prospective Bidders with respect to subsurface conditions, other physical conditions and Underground Facilities, and possible changes in the Bidding Documents due to differing or unforeseen conditions appear in Paragraphs 4.02, 4.03 and 4.04 of the General Conditions. Provisions concerning responsibilities for the adequacy of data furnished to prospective Bidders with respect to a Hazardous Environmental Condition at the Site, if any, and possible changes in the Bidding Documents due to any Hazardous Environmental Condition uncovered or revealed at the Site which was not shown or indicated in the Drawings or Specifications or identified in the Contract Documents to be within the scope of the Work appear in Paragraph 4.06 of the General Conditions.
- 6.05 A single Site visit will take place following the pre-bid conference. Participants will meet at Temple Water Treatment Plant, 255 West Arrow Highway, Glendora, CA. No other Site visits will be permitted.
- 6.06 Reference is made to the Section 01110 for identification of the general nature of other work that is to be performed at the Site by Owner or others (such as utilities and other prime contractors) that relates to the Work for which a Bid is to be submitted. On request, Owner will provide to Bidder, for examination, access to or copies of the contract documents for such other work.
- 6.07 It is the responsibility of Bidder, before submitting a Bid to:
- A. examine and carefully study the Bidding Documents, the other related data identified in the Bidding Documents and any Addenda;
  - B. visit the Site and become familiar with and satisfy Bidder as to the general, local and Site conditions that may affect cost, progress and performance of the Work;
  - C. become familiar with and satisfy Bidder as to all federal, state and local Laws and Regulations that may affect cost, progress and performance of the Work;
  - D. carefully study all reports of explorations and tests of subsurface conditions at or contiguous to the Site and all drawings of physical conditions in or relating to existing surface or subsurface structures at or contiguous to the Site (except Underground Facilities) which have been identified in the Supplementary Conditions as provided in Paragraph 4.02 of the General Conditions, and
  - E. obtain and carefully study (or assume responsibility for doing so) all additional or supplementary examinations, investigations, explorations, tests, studies, and data concerning conditions (surface, subsurface and Underground Facilities) at or

contiguous to the Site which may affect cost, progress or performance of the Work or which relate to any aspect of the means, methods, techniques, sequences and procedures of construction to be employed by Bidder, including any specific means, methods, techniques, sequences and procedures of construction expressly required by the Bidding Documents, and safety precautions and programs incident thereto;

- F. agree at the time of submitting its Bid that no further examinations, investigations, explorations, tests, studies, or data are necessary for the determination of its Bid for the performance of the Work at the price(s) bid and within the times and in accordance with the other terms and conditions of the Bidding Documents;
  - G. become aware of the general nature of work (if any) to be performed by Owner and others at the Site that relates to the Work as indicated in the Bidding Documents;
  - H. correlate the information known to Bidder, information and observations obtained from visits to the Site, reports and drawings identified in the Bidding Documents, and all additional examinations, investigations, explorations, tests, studies and data with the Bidding Documents;
  - I. promptly give Engineer written notice of all conflicts, errors, ambiguities or discrepancies that Bidder discovers in the Bidding Documents and confirm that the written resolution thereof by Engineer is acceptable to Bidder; and
  - J. determine that the Bidding Documents are generally sufficient to indicate and convey understanding of all terms and conditions for the performance of the Work.
- 6.08 The submission of a Bid will constitute an incontrovertible representation by Bidder that Bidder has complied with every requirement of this Article 6, that without exception the Bid is premised upon performing the Work required by the Bidding Documents and applying any specific means, methods, techniques, sequences or procedures of construction that may be shown or indicated and expressly required by the Bidding Documents, that Bidder has given Engineer written notice of all conflicts, errors, ambiguities and discrepancies that Bidder has discovered in the Bidding Documents and the written resolutions thereof by Engineer are acceptable to Bidder, and that the Bidding Documents are generally sufficient to indicate and convey understanding of all terms and conditions for performing the Work.

#### ARTICLE 7 - PRE-BID CONFERENCE

- 7.01 A pre-Bid conference will be held at 9:00 AM local time on Tuesday, January 26, 2010 at Temple Water Treatment Plant, 255 West Arrow Highway, Glendora, CA. Representatives of Owner and Engineer will be present to discuss the Project. Bidders are encouraged to attend and participate at the conference. Engineer will transmit to all prospective Bidders of record such Addenda as Engineer considers



necessary in response to questions raised at the conference. Oral statements may not be relied upon and will not be binding or legally effective.

#### ARTICLE 8 - SITE AND OTHER AREAS

- 8.01 The Site is identified in the Bidding Documents. Easements for permanent structures or permanent changes in existing facilities are to be obtained and paid for by Owner unless otherwise provided in the Bidding Documents. All additional lands and access thereto required for temporary construction facilities, construction equipment, or storage of materials and equipment, to be incorporated into the Work are to be obtained and paid for by Contractor.

#### ARTICLE 9 - INTERPRETATIONS AND ADDENDA

- 9.01 All questions about the meaning or intent of the Bidding Documents shall be submitted to Engineer in writing. In order to receive consideration, questions must be received by Engineer at least ten days prior to the date for the opening of Bids. Interpretations or clarifications considered necessary by Engineer in response to such questions will be issued by Addenda mailed or delivered to all parties recorded by Engineer as having received the Bidding Documents for receipt not later than three (3) days prior to the date for the opening of Bids. Only questions answered by Addenda will be binding. Oral and other interpretations or clarifications will be without legal effect.
- 9.02 Addenda may also be issued to clarify, correct or change the Bidding Documents as deemed advisable by Owner or Engineer. Such Addenda, if any, will be issued in the manner and within the time period stated in Paragraph 9.01.

#### ARTICLE 10 - BID SECURITY

- 10.01 A Bid must be accompanied by Bid security made payable to the Owner in the amount of ten percent (10%) of Bidder's maximum Bid price and in the form of Bid bond.
- 10.02 Bid bond shall be on a separate form furnished by Engineer. An example of the Bid bond is bound in the Project Manual. Bid bond shall be issued by a surety meeting the requirements of Paragraphs 5.01 and 5.02 of the General Conditions.
- 10.03 The Bid security of the Successful Bidder will be retained until such Bidder has executed the Contract Documents, furnished the required contract security and met the other conditions of the Notice of Award, whereupon the Bid security will be returned. If the Successful Bidder fails to sign and deliver the Contract Documents and furnish the required contract security within fifteen (15) days after the Notice of

Award, Owner may annul the Notice of Award and may retain from the Bid security an amount equal to the damages which Owner may suffer by reason of such failure. Said damages shall be the difference between that Bidder's Bid and the Bid of the next lowest, responsible and responsive Bidder, but such amount shall not exceed the Bid security amount, and, if there is no such next lowest, responsible and responsive Bidder, then the Bid security amount of that Bidder will be forfeited to the Owner as liquidated damages for such failure.

- 10.04 The Bid security of other Bidders whom Owner believes to have a reasonable chance of receiving the award may be retained by Owner until the earlier of the seventh day after the Effective Date of the Agreement or the sixty-first day after the Bid opening, whereupon the Bid security furnished by such Bidders will be returned. The Bid security of Bidders whom Owner believes do not have a reasonable chance of receiving an award will be returned within seven days of the Bid opening.

#### ARTICLE 11 - CONTRACT TIMES

- 11.01 The number of days within which or dates by which Milestones are to be achieved and the Work is to be substantially completed and also completed and ready for final payment (the Contract Times) are set forth in the Agreement.

#### ARTICLE 12 - LIQUIDATED AND SPECIAL DAMAGES

- 12.01 Provisions for liquidated and special damages, if any, are set forth in the Agreement.

#### ARTICLE 13 - SUBSTITUTE AND "OR EQUAL" ITEMS

- 13.01 The Contract, if awarded, will be on the basis of materials and equipment specified or described in the Bidding Documents without consideration of possible substitute or "or-equal" items. Whenever it is specified or described in the Bidding Documents that a substitute or "or-equal" item of material or equipment may be furnished or used by Contractor if acceptable to Engineer, application for such acceptance will not be considered by Engineer until after the Effective Date of the Agreement. The procedure for submittal of any such application by Contractor and consideration by Engineer is set forth in the General Conditions which may be supplemented in the General Requirements.
- 13.02 Refer to Section 01630 of the General Requirements for the period of time after the Effective Date of the Agreement during which the Engineer will accept applications for substitute items of material or equipment.

#### ARTICLE 14 - SUBCONTRACTORS, SUPPLIERS AND OTHERS

- 14.01 If the Supplementary Conditions require the identity of certain Subcontractors, Suppliers, individuals or entities to be submitted to Owner in advance of a specified date prior to the Effective Date of the Agreement, the apparent Successful Bidder, and any other Bidder so requested, shall within five (5) days after Bid opening submit to Owner a list of all such Subcontractors, Suppliers, other individuals or entities proposed for those portions of the Work for which such identification is required. Such list shall be accompanied by an experience statement with pertinent information regarding similar projects and other evidence of qualifications for each such Subcontractor, Supplier, individual or entity if requested by Owner. If Owner or Engineer, after due investigation, has reasonable objection to any proposed Subcontractor, Supplier, individual or entity, Owner may, before the Notice of Award is given, request the apparent Successful Bidder to submit an acceptable substitute without an increase in Bid price.
- 14.02 If apparent Successful Bidder declines to make any such substitution, Owner may award the Contract to the next lowest Bidder that proposes to use acceptable Subcontractors, Suppliers and other individuals or entities. Declining to make requested substitutions will not constitute grounds for forfeiture of the Bid security of any Bidder. Any Subcontractor, Supplier, individual or entity so listed and against which Owner or Engineer makes no written objection prior to the giving of the Notice of Award will be deemed acceptable to Owner and Engineer subject to revocation of such acceptance after the Effective Date of the Agreement as provided in Paragraph 6.06 of the General Conditions.
- 14.03 Where the Contract Price is on the basis of cost-plus, the apparent Successful Bidder, prior to the Notice of Award, shall identify in writing to Owner those portions of the Work that such Bidder proposes to subcontract and after the Notice of Award may only subcontract other portions of the Work with Owner's written consent.
- 14.04 Contractor shall not be required to employ any Subcontractor, Supplier, individual or entity against whom Contractor has reasonable objection.

#### ARTICLE 15 - PREPARATION OF BID

- 15.01 A Bid shall be made on the unbound copy of the Bid Form furnished by Engineer. The Bid Form shall not be altered in any way.
- 15.02 All blanks in the Bid Form shall be completed by printing in ink or by typewriter and the Bid signed in ink. Erasures or alterations shall be initialed in ink by the person signing the Bid Form. A Bid price shall be indicated for each Bid item listed therein or the words "No Bid", "No Change", or "Not Applicable" entered. Ditto marks shall not be used.
- 15.03 A Bid shall be executed as stated below.

- A. A Bid by an individual shall show the Bidder's name and official address.
  - B. A Bid by a partnership shall be executed in the partnership name and signed by a partner (whose title shall appear under the signature), accompanied by evidence of authority to sign. The official address of the partnership shall be shown below the signature.
  - C. A Bid by a joint venture shall be executed by each joint venturer in the manner indicated on the Bid Form. The official address of the joint venture shall be shown below the signature.
  - D. A Bid by a corporation shall be executed in the corporate name by an officer of the corporation and shall be accompanied by a certified copy of a resolution of the board of directors authorizing the person signing the Bid to do so on behalf of the corporation. The corporate seal shall be affixed and attested by the secretary or an assistant secretary. The state of incorporation and the official corporate address shall be shown below the signature.
  - E. A Bid by a limited liability company shall be executed in the name of the firm by a member and accompanied by evidence of authority to sign. The state of formation of the firm and the official address of the firm shall be shown below the signature.
  - F. All names shall be typed or printed in ink below the signature.
  - G. If applicable, the Bid shall contain evidence of Bidder's authority and qualification to do business in the state where the Project is located.
- 15.04 The Bid shall contain an acknowledgment of the receipt of all Addenda, the numbers of which shall be filled in at the space provided on the Bid Form.
- 15.05 The address and telephone number for communications regarding the Bid shall be shown.
- 15.06 In addition to the Bid Form, the following listed documents, which will be furnished by Engineer, shall be submitted with the Bid. Each document shall be executed in the manner described in Paragraph 15.03 unless another manner is indicated.
- A. Bid Security Form.
  - B. Bidder Qualifications Statement.
  - C. Non-collusive Bidding Certification (if required by statute).

## ARTICLE 16 - BASIS OF BIDS; COMPARISON OF BIDS

- 16.01 Base Bid with Unit Price Items and Alternatives
- A. Bidder shall submit its Bid on the basis of a single lump sum as set forth in the Bid Form.
  - B. For each unit price item on the Bid Form, Bidder shall enter the unit price Bid, and shall enter the computation of the respective quantity times the Bidder's unit price for that item. Bidder shall compute and enter in the space provided on the Bid form, the total of the products of quantity and unit price Bid for each unit price item.
  - C. Bidder shall submit its Bid on the basis of a lump sum for the Base Bid with unit price items as provided for on the Bid Form.
  - D. For determination of the relative Bid aggregate amounts, Bids will be compared on the total of lump sum Bid plus the products of quantity and unit price Bid for each unit price item.
- 16.03 Discrepancies between the multiplication of units of Work and unit prices will be resolved in favor of the unit prices. Discrepancies between the indicated sum of any column of figures and the correct sum thereof will be resolved in favor of the correct sum.

## ARTICLE 17 - SUBMITTAL OF BID

- 17.01 A Bid shall be submitted no later than the date and time prescribed and at the place indicated in the Invitation to Bid.
- 17.02 Bid shall be enclosed in an opaque sealed envelope plainly marked on the outside with the Project title and the name and address of the Bidder and its license or registration number, if applicable. Bid shall be accompanied by Bid security and other required documents.
- 17.03 If the Bid is sent by mail or other delivery system, the sealed envelope containing the Bid shall be enclosed in a separate envelope plainly marked on the outside with the notation "BID ENCLOSED". A mailed Bid shall be addressed to: Covina Irrigating Company, 146 E. College St., Covina, CA 91723-0306.

## ARTICLE 18 - MODIFICATION OR WITHDRAWAL OF BID

- 18.01 Withdrawal Prior to Bid Opening:

- A. A Bid may be withdrawn by an appropriate document duly executed, in the manner that a Bid must be executed and delivered to the place where Bids are to be submitted prior to the date and time fixed for the opening of Bids. Upon receipt of such written notice, the unopened Bid will be returned to the Bidder.

18.02 Modification Prior to Bid Opening:

- A. If a Bidder wishes to modify its Bid, Bidder must withdraw its initial Bid in the manner specified in Paragraph 18.01.A and submit a new Bid.

ARTICLE 19 - OPENING OF BIDS

- 19.01 Bids will be opened privately.
- 19.02 Bids received by mail or otherwise after the date and time specified for the opening of Bids will not be accepted and will be returned to the Bidder unopened.

ARTICLE 20 - DISQUALIFICATION OF BIDDERS

- 20.01 More than one Bid for the same Work from an individual or entity under the same or different names will not be considered. Reasonable grounds for believing that any Bidder has an interest in more than one Bid for the Work may be cause for disqualification of that Bidder and the rejection of all Bids in which that Bidder has an interest.

ARTICLE 21 - BIDS TO REMAIN SUBJECT TO ACCEPTANCE

- 21.01 All Bids shall remain subject to acceptance for the period of time stated in the Bid Form, but Owner may, in its sole discretion, release any Bid and return the Bid security prior to that date.

ARTICLE 22 - EVALUATION OF BIDS AND AWARD OF CONTRACT

- 22.01 Owner reserves the right to reject any or all Bids, including without limitation the right to reject any or all nonconforming, non-responsive, unbalanced, or conditional Bids. Owner further reserves the right to reject the Bid of any Bidder whom it finds, after reasonable inquiry and evaluation, to be non-responsible. Owner also reserves the right to waive any informality not involving price, time or changes in the Work, and to negotiate contract terms with the Successful Bidder.
- 22.02 Owner reserves the right to reject any Bid not accompanied by specified documentation and Bid security.

- 22.03 Owner reserves the right to reject any Bid that, in its sole discretion, is considered to be unbalanced or unreasonable as to the amount bid for any lump sum or unit price item.
- 22.04 In evaluating Bidders, Owner will consider the qualifications of Bidders, whether or not their Bids comply with the prescribed requirements, the alternatives, if any, the lump sum and unit prices, and other data as may be requested in the Bid Form or prior to the Notice of Award.
- 22.05 Owner may consider the qualifications and experience of Subcontractors, Suppliers and other individuals or entities proposed for those portions of the Work for which the identity of Subcontractors, Suppliers and other individuals or entities must be submitted as provided in the Supplementary Conditions.
- 22.06 Owner may conduct such investigations as Owner deems necessary to establish the responsibility, qualifications and financial ability of the Bidders to perform the Work in accordance with the Contract Documents. Owner reserves the right to reject the Bid of any Bidder who does not pass any such evaluation to Owner's satisfaction.
- 22.07 Owner reserves the right to accept any Bid deemed to be in its best interests even though the Bid chosen may result in the award of the Contract to a Bidder whose Bid is not, on a mathematical basis alone, the low Bid.

#### ARTICLE 23 - CONTRACT SECURITIES

- 23.01 Performance Bond shall be in the form of Engineers Joint Contract Documents Committee (EJCDC) "Construction Performance Bond", C-610. Payment Bond shall be in the form of EJCDC "Construction Payment Bond", C-615. The amounts of and other requirements for Performance and Payment Bonds are stated in Paragraph 5.01 of the General Conditions. The requirements for delivery of Bonds are stated in Paragraph 2.01 of the General Conditions. Additional requirements may be stated in the Supplementary Conditions.
- 23.02 Successful Bidder shall within five days from the date of the Notice of Award deliver to Owner, for Owner's review and approval, the Performance Bond and the Payment Bond Contractor proposes to furnish at the time of the execution of the Agreement.

#### ARTICLE 24 - CONTRACTOR'S INSURANCE

- 24.01 The requirements for Contractor's insurance are stated in Article 5 of the General Conditions and in the Supplementary Conditions. The requirements for delivery of certificates of insurance are stated in Paragraph 2.01.B of the General Conditions.

24.02 Successful Bidder shall within five days from the date of the Notice of Award deliver to Owner, for review and approval, the required policies of insurance. Upon approval, the policies will be returned to the Bidder and Bidder shall submit certificates of insurance to the Owner as stated in the General Conditions.

#### ARTICLE 25 - SIGNING OF AGREEMENT

25.01 When Owner gives a Notice of Award to the Successful Bidder, it will be accompanied by the required number of unsigned counterparts of the Agreement with the other Contract Documents which are identified in the Agreement as attached thereto. Within 15 days thereafter, Successful Bidder shall sign and deliver the required number of counterparts of the Agreement and attached documents to Owner. Within ten days thereafter, Owner will deliver one fully signed counterpart to Successful Bidder with a complete set of the Drawings with appropriate identification.

#### ARTICLE 26 - NOTICE TO PROCEED

26.01 Issuance of the Notice to Proceed shall be as stated in Article 2 of the General Conditions.

#### ARTICLE 27 - SALES AND USE TAXES

27.01 Refer to Supplementary Conditions paragraph SC-6.10 for information on Owner's exemption from sales and use taxes on materials and equipment to be incorporated into the Work. Do not include said taxes in Bid.

++ END OF INSTRUCTIONS TO BIDDERS ++



---

# COVINA IRRIGATING COMPANY

---



[Contractor Name]  
[Address]  
[Address]  
[Address]

Dear Mr. [Ms, Mrs, etc]:

Your firm has been invited to bid for the construction contract of the UV/Chloramines Project at the Temple Water Treatment Plant in Glendora, CA. Sealed Bids for the construction of the UV/Chloramines Facility will be received, from invited bidders only, by the Covina Irrigating Company, at their office, until 1:00 PM Local Time on **February 16, 2010**, at which time they will be privately opened and read.

Bids shall be on a lump sum basis for the General Construction Contract.

Bidding Documents are enclosed with this letter; additional copies may be purchased for \$\_\_\_\_\_ per set from \_\_\_\_\_. Neither the Owner nor the Engineer will be responsible for full or partial sets of Bidding Documents, including any addenda, obtained from other sources.

Bid security shall be provided in accordance with Article 10 of the Instructions to Bidders.

Bidders shall provide proof of qualifications to perform the Work as described in Article 5 of the Instructions to Bidders.

Contract time of commencement and completion will be in accordance with Article 4 of the Agreement.

**Location & Description of the Work:**

The work is located on the site of Covina Irrigating Company's Temple Water Treatment Plant at 255 West Arrow Highway, Glendora, CA 91740. The project includes construction of a new UV treatment facility and pump station, a new chemical feed facility, and various site improvements. The new UV treatment facility and pump station will be a single sub-grade concrete structure with an above-ground air-conditioned masonry electrical building. The pump station will include five vertical turbine pumps of various sizes with a pre-fabricated metal canopy overhead and a wet well for storage of finished water. The new chemical feed facility will include a new FRP chemical storage tank, a new steel chemical storage tank, chemical feed pumps and piping, a concrete containment area, and pre-fabricated metal canopy. Chemical feed pumps and piping shall be installed within existing facilities and areas of the site

as well. Site improvements such as a new security fence and paving of the entire site are also included, as well as a new sand settling basin and installation of backwash recycle pumps.

**Questions:**

For questions related to the project or regarding this bidding process, please contact the Engineer:

Mark Strahota, PE  
Malcolm Pirnie, Inc.  
8001 Irvine Center Drive  
Suite 1100  
Irvine, CA 92618

All communications concerning this Invitation to Bid (ITB) must be in writing. Written questions regarding details of this ITB will be accepted (i.e., must be received) by the Engineer until 5:00 P.M., Pacific Standard Time (PST), **February 5, 2010**. Written questions must be sent via standard mail to the address above, via facsimile at (949) 450-9902, or via electronic telecommunication (email) at [mstrahota@pirnie.com](mailto:mstrahota@pirnie.com). All questions submitted to the Engineer's street address or by facsimile shall contain the following title in the inquiry; questions submitted via e-mail shall contain the following title in the Subject line: "UV/Chloramines Project: Bidder Questions." Telephone questions will not be accepted. Any questions received after the indicated date may not receive a response.

Sincerely,

David D. De Jesus  
President  
Covina Irrigating Company

## SUPPLEMENTARY CONDITIONS

### SCOPE

These Supplementary Conditions amend or supplement the General Conditions. All provisions of the General Conditions that are not so amended or supplemented remain in full force and effect.

The terms used in these Supplementary Conditions which are defined in the General Conditions have the meanings assigned to them in the General Conditions. Additional terms used in these Supplementary Conditions have the meanings stated below, which are applicable to the singular and plural thereof.

SC-4.02            Add a new Paragraph immediately after Paragraph 4.02.B that is to read as follows:

SC-4.02.C In the preparation of the Drawings and Specifications, Engineer has relied upon:

1. The following report of explorations and tests of subsurface conditions at the Site.
  - a. Geotechnical Evaluation, Covina Irrigating Company, 225 West Arrow Highway, Glendora, California by Ninyo and Moore, December 2007.  
Supplemental Geotechnical Recommendations, Covina Irrigating Company, 225 West Arrow Highway, Glendora, California by Ninyo and Moore, April 2009.
  - b. The technical data contained in such report upon which Contractor may rely are: the boring method, the locations and logs of the borings, the levels of subsurface water (if any), laboratory test methods and results, and similar factual data. Bore hole information represents subsurface characteristics to the extent indicated, only for the point location of the bore hole and, with regard to the level of subsurface water (if any), only at the time the boring was made. Contractor shall make its own interpretations of the subsurface characteristics to be encountered between bore holes and its own interpretations of the fluctuation of the level of subsurface water (if any) at and between bore holes.
  - c. A copy of the above report is available for review at Covina Irrigating Company, 146 East College Street, Covina, CA, upon 48 hours' notice to the Covina Irrigating Company.

SC-4.06            Delete Paragraphs 4.06.A and 4.06.B in their entirety and insert the following:

SC-4.06.A. In the preparation of the Drawings and Specifications, Engineer has not utilized any report or drawing related to a Hazardous Environmental Condition identified at the Site.

SC-4.06.B (Not Used)

SC-5.06 through SC-5.09, inclusive.

Add new paragraphs immediately after Paragraph 5.05 that are to read as follows:

SC-5.06. *Property Insurance*

- A. Contractor shall purchase and maintain property insurance upon the Work at the Site in the amount of the full replacement cost of the Work. This insurance shall:
  - 1. include the interests of Owner, Contractor, Subcontractors, Engineer, and other individuals or entities identified herein, and the officers, directors, partners, employees, agents and other consultants and subcontractors of each and any of them, each of whom is deemed to have an insurable interest and shall be listed as an insured or additional insured;
  - 2. be written on a Builder's Risk "all-risk" or open peril or special causes of loss policy form that shall at least include insurance for physical loss or damage to the Work, temporary buildings, falsework, and materials and equipment in transit, and shall insure against at least the following perils or causes of loss: fire, lightning, extended coverage, theft, vandalism and malicious mischief, earthquake, collapse, debris removal, demolition occasioned by enforcement of Laws and Regulations, water damage, and mechanical and electrical breakdown or failure, and damage to electrical apparatus from electrical currents;
  - 3. include expenses incurred in the repair or replacement of any insured property (including but not limited to fees and charges of engineers and architects);
  - 4. cover materials and equipment stored at the Site or at another location that was agreed to in writing by Owner prior to being incorporated in the Work, provided that such materials and equipment have been included in an Application for Payment recommended by Engineer;

5. allow for partial utilization of the Work by Owner;
  6. include testing and start-up; and
  7. be maintained in effect until final payment is made unless otherwise agreed to in writing by Owner, Contractor and Engineer with 30 days written notice to each other additional insured to whom a certificate of insurance has been issued.
- B. Contractor shall purchase and maintain boiler and machinery insurance which will include the interests of Owner, Contractor, Subcontractors, Engineer, and other individuals or entities identified in this Paragraph SC-5.06, each of whom is deemed to have an insurable interest and shall be listed as an insured or additional insured.
- C. All the policies of insurance (and the certificates or other evidence thereof) required to be purchased and maintained in accordance with Paragraph SC-5.06 will contain a provision or endorsement that the coverage afforded will not be canceled or materially changed or renewal refused until at least 30 days prior written notice has been given to Owner and Contractor and to each other additional insured to whom a certificate of insurance has been issued and will contain waiver provisions in accordance with Paragraph SC-5.07.
- D. The risk of loss within any deductible amount applicable to the policies of insurance purchased in accordance with this Paragraph SC-5.06 will be borne by Contractor, Subcontractors, or others suffering such loss.

*SC-5.07. Waiver of Rights*

- A. Owner and Contractor intend that all policies purchased in accordance with Paragraph SC-5.06 will protect Owner, Contractor, Subcontractors, Engineer, and all other individuals or entities identified in Paragraph SC-5.06 to be listed as insureds or additional insureds (and the officers, directors, partners, employees, agents, and other consultants and subcontractors of each and any of them) in such policies and will provide primary coverage for all losses and damages caused by the perils or causes of loss covered thereby. All such policies shall contain provisions to the effect that in the event of payment of loss or damage the insurers will have no rights of recovery

against any of the insureds or additional insureds thereunder. Owner and Contractor waive all rights against each other and their respective officers, directors, partners, employees, agents and other consultants and subcontractors of each and any of them for all losses and damages caused by, arising out of or resulting from any of the perils or causes of loss covered by such policies and any other property insurance applicable to the Work; and, in addition, waive all such rights against Subcontractors, Engineer, and all other individuals or entities identified in Paragraph SC-5.06 to be listed as insureds or additional insureds (and the officers, directors, partners, employees, agents and other consultants and subcontractors of each and any of them) under such policies for losses and damages so caused. None of the above waivers shall extend to the rights that any party making such waiver may have to the proceeds of insurance held by Owner as trustee or otherwise payable under any policy so issued.

- B. Owner waives all rights against Contractor, Subcontractors, Engineer, and the officers, directors, partners, employees, agents, and other consultants and subcontractors of each and any of them for loss or damage to the completed Project or part thereof caused by, arising out of, or resulting from fire or other insured peril or cause of loss covered by any property insurance maintained on the completed Project or part thereof by Owner during partial utilization pursuant to Paragraph 14.05, after Substantial Completion pursuant to Paragraph 14.04 or after final payment pursuant to Paragraph 14.07.
- C. Any insurance policy maintained by Owner covering any loss, damage, or consequential loss referred to in Paragraph SC-5.07.B shall contain provisions to the effect that in the event of payment of any such loss, damage or consequential loss, the insurers will have no rights of recovery against Contractor, Subcontractors, Engineer, and the officers, directors, partners, employees, agents and other consultants and subcontractors of each and any of them.

SC-5.08. *Receipt and Application of Insurance Proceeds*

- A. Any insured loss under the policies of insurance required by Paragraph SC-5.06 will be adjusted with Owner and made payable to Owner as fiduciary for the insureds, as their interests may appear, subject to the requirements of any applicable mortgage clause and of Paragraph SC-5.08.B. Owner shall deposit in a separate account any money so received and shall distribute it in accordance with such agreement as the parties in interest may reach. If no other special agreement is reached, the damaged Work shall be repaired or replaced, the moneys so received applied on account thereof and the Work and the cost thereof covered by an appropriate Change Order.
- B. Owner as fiduciary shall have power to adjust and settle any loss with the insurers unless one of the parties in interest shall object in writing within 15 days after the occurrence of loss to Owner's exercise of this power. If such objection be made, Owner as fiduciary shall make settlement with the insurers in accordance with such agreement as the parties in interest may reach. If no such agreement among the parties in interest is reached, Owner as fiduciary shall adjust and settle the loss with the insurers and, if required in writing by any party in interest, Owner as fiduciary shall give bond for the proper performance of such duties.

SC-5.09. *Partial Utilization, Acknowledgment of Property Insurer*

- A. If Owner finds it necessary to occupy or use a portion or portions of the Work prior to Substantial Completion of all the Work as provided in Paragraph 14.05, no such use or occupancy shall commence before the insurers providing the property insurance pursuant to Paragraph SC-5.06 have acknowledged notice thereof and in writing effected any changes in coverage necessitated thereby. The insurers providing the property insurance shall consent by endorsement on the policy or policies, but the property insurance shall not be canceled or permitted to lapse on account of any such partial use or occupancy.

SC-6.02.B

Add new paragraphs immediately after Paragraph 6.02.B that are to read as follows:

SC-6.02.B.1 Except where otherwise prohibited by Laws or Regulations, regular working hours are defined as up to eight hours per day, beginning no earlier than 7:00 a.m. and ending no later than 6:00 p.m. The Contractor will be provided with the combination to the entrance gate for their entrance and exit.

SC-6.02.B.2 Maintenance and cleanup activities may be performed during hours other than regular working hours provided that such activities do not require the startup or operation of construction equipment.

SC-6.02.B.3 If it shall become absolutely necessary to perform Work at night or on Saturdays, Sundays, or legal holidays, written notice shall be submitted to Owner and Engineer at least seven days in advance of the need for such Work. Owner will only consider the performance of such Work as can be performed satisfactorily under the conditions. Good lighting and all other necessary facilities for carrying out and observing the Work shall be provided and maintained where such Work is being performed at night.

SC-6.12. Add a new paragraph immediately after Paragraph 6.12.A, that is to read as follows:

SC-6.12.B Contractor will be required to review with Engineer the status of record documents in connection with the Engineer's review of an Application for Payment. Failure to maintain record document current may be just cause for Engineer to recommend withholding of payments for Work performed.

SC-6.15 Add a new paragraph immediately after Paragraph 6.15.A that is to read as follows:

SC-6.15.B Contractor shall be responsible for coordinating exchange of material safety data sheets or other hazard communication information required to be made available to or exchanged between or among employers at the Site in accordance with all Laws and regulations. Contractor shall provide a centralized location for the maintenance of the material safety data sheets or other hazard communication information required to be made available by any employer on the Site. Location of the material safety data sheets or other hazard communication information shall be readily accessible to the employees of employers on the Site.

SC-6.17 Add the following new paragraphs immediately after Paragraph 6.17.E that are to read as follows:



SC-6.17.F Contractor shall furnish required submittals with sufficient information and accuracy to obtain required approval or acceptance of submittal with no more than three submittals. Engineer will record Engineer's time for reviewing subsequent submittals of Shop Drawings, samples or other items requiring approval or acceptance, and Contractor shall reimburse Owner for Engineer's charges for such time.

SC-6.17.G In the event that Contractor requests a substitution for a previously approved item, Contractor shall reimburse Owner for Engineer's charges for such time unless the need for such substitution is beyond the control of Contractor.

SC-9.03

Add a new paragraph immediately after Paragraph 9.03.A that is to read as follows:

SC-9.03.B Resident Project Representative (RPR) will be Owner's Representative or Engineer at the Site, will act as directed by and under the supervision of Engineer, and will confer with Engineer regarding RPR's actions. RPR's dealings in matters pertaining to the Work shall in general be with Engineer and Contractor keeping Owner advised as necessary. RPR's dealings with Subcontractors shall only be through or with the full knowledge and approval of Contractor. RPR shall generally communicate with Owner with the knowledge of and under the direction of Engineer.

1. Duties and Responsibilities to RPR:
  - a. Schedules: Review the Progress Schedule, Schedule of Submittals, and Schedule of Values prepared by Contractor and consult with Engineer concerning acceptability.
  - b. Conferences and Meetings: Attend meetings with Contractor, such as preconstruction conferences, progress meetings, job conferences, and other Project-related meetings, and prepare and circulate copies of minutes thereof.
  - c. Liaison:
    - 1) Serve as Engineer's liaison with Contractor, working principally through Contractor's superintendent, and assist in providing understanding of the intent of the Contract Documents; and assist Engineer in serving as Owner's liaison with Contractor when Contractor's operations affect Owner's operations on the Site.
    - 2) Assist in obtaining from Owner additional details or information, when required for proper execution of the Work.
  - d. Shop Drawings and Samples:
    - 1) Record date of receipt of Shop Drawings and Samples, that are received at the Site.

- 2) Receive Samples that are furnished at the Site by Contractor, and notify Engineer of availability of Samples for examination.
  - 3) Advise Engineer and Contractor of the commencement of any Work requiring a Shop Drawing or Sample if the submittal has not been approved by Engineer.
- e. Review of Work, Rejection of Defective Work, Inspections and Tests:
- 1) Conduct observations of the Work in progress on the Site to assist Engineer in determining if the Work is, in general, proceeding in accordance with the Contract Documents.
  - 2) Report to Engineer when RPR believes that any Work is unsatisfactory, faulty, or defective or does not conform generally to the Contract Documents, or has been damaged, or does not meet the requirements of any inspection, test, or approval required to be made; and advise Engineer of Work that RPR believes should be corrected or rejected or should be uncovered for observation, or requires special testing, inspection, or approval.
  - 3) Verify that tests, equipment, and systems startups, and operating and maintenance training are conducted in the presence of appropriate Owner's personnel, and that Contractor maintains adequate records thereof; and observe, record, and report to Engineer appropriate details relative to the test procedures and startups.
  - 4) Accompany visiting inspectors representing public or other agencies having jurisdiction over the Project, record the results of these inspections and report to Engineer.
- f. Interpretation of Contract Documents: Report to Engineer when clarifications and interpretations of the Contract Documents are needed and transmit to Contractor clarifications and interpretations as issued by Engineer.
- g. Modifications: Consider and evaluate Contractor's suggestions for modifications to Drawings or Specifications and report with RPR's recommendations to Engineer. Transmit to Contractor decisions issued by Engineer.
- h. Records:
- 1) Maintain at the Site orderly files for correspondence, reports of job conferences, Shop Drawings and Samples, and reproductions of original Contract Documents including all Addenda, Change Orders, Work Change Directives, Field Orders, additional Drawings issued subsequent to the execution of the Agreement, Engineer's clarifications and interpretations of the Contract

- Documents, progress reports, and other Project-related documents.
- 2) Keep a record recording Contractor's hours on the Site, weather conditions, data relative to questions on Change Orders or changed conditions, list of visitors to the Site, daily activities, decisions, observations in general, and specific observations in more detail as in the case of observing test procedures; and send copies to Engineer.
  - 3) Record names, addresses, and telephone numbers of all Contractors, Subcontractors, and major Suppliers of materials and equipment.
- i. Reports:
- 1) Furnish Engineer periodic reports as required of progress of the Work and of Contractor's compliance with the Progress Schedule and Schedule of Submittals.
  - 2) Consult with Engineer in advance of scheduled major tests, inspections, or start of important phases of the Work.
  - 3) Prepare draft of proposed Change Orders, obtaining backup documents from Contractor, and provide recommendations to Engineer regarding Change Orders and Field Orders.
  - 4) Report immediately to Engineer and Owner upon the occurrence of any Site accident, any Hazardous Environmental Condition, emergencies or acts of God endangering the Work, or property damage by fire or other cause.
- j. Payment Requests: Review Applications for Payment with Contractor for compliance with the established procedure for their submission, and submit recommendations to Engineer, noting particularly the relationship of the payment requested to the Schedule of Values, Work completed, and materials and equipment delivered at the Site but not incorporated in the Work.
- k. Certificates, Maintenance and Operation Manuals: During the course of the Work, verify that certificates, maintenance and operation manuals, and other data required by the Specifications to be assembled and furnished by Contractor are applicable to the items actually installed and in accordance with the Contract Documents, and have this material delivered to Engineer for review and forwarding to Owner prior to final payment for the Work.
- l. Completion:
- 1) Before Engineer issues a certificate of Substantial Completion, submit to Contractor a list of observed items requiring completion or correction.

- 2) Observe whether Contractor has arranged for inspections required by Laws and Regulations, including but not limited to those to be performed by public authorities having jurisdiction over the Work.
  - 3) Conduct final inspection in the company of Engineer, Owner, and Contractor, and prepare a final list of items to be completed or corrected.
  - 4) Observe that all items on final list have been completed or corrected and make recommendations to Engineer concerning acceptance of the Work.
2. Limitations of Authority of RPR: RPR shall not:
- a. Authorize any deviation from the Contract Documents or substitution of materials or equipment, including “or equal” items.
  - b. Exceed limitations of Engineer’s authority as set forth in the Contract Documents.
  - c. Undertake any of the responsibilities of Contractor, Subcontractors, or Contractor’s superintendent.
  - d. Advise on, issue directions relative to, or assume control over any aspect of the means, methods, techniques, sequences or procedures of construction, unless such advice or directions are specifically required by the Contract Documents.
  - e. Advise on, issue directions regarding, or assume control over safety precautions and programs in connection with the Work.
  - f. Accept Shop Drawing or Sample submittals from anyone other than Contractor.
  - g. Authorize Owner to occupy the Project in whole or in part.
  - h. Participate in specialized field or laboratory tests or inspections conducted by others except as specifically authorized by Engineer.

SC-16.01 Add new paragraphs immediately after Paragraph 16.01.A that are to read as follows:

SC-16.01.B Either Owner or Contractor may request mediation of any Claim submitted to Engineer for a decision under Paragraph 10.05 before such decision becomes final and binding. The mediation will be governed by the The American Arbitration Association under the Construction Industry Mediation Rules of the American Arbitration Association in effect as of the Effective Date of the Agreement. The request for mediation shall be submitted in writing to the American Arbitration Association and the other party to the Contract. Timely submission of the request shall stay the effect of Paragraph 10.05.E.

SC-16.01.C Owner and Contractor shall participate in the mediation process in good faith. The process shall be concluded within 60 days of filing of the request. The date of termination of the mediation shall be determined by application of the mediation rules referenced above.

SC-16.01.D If the Claim is not resolved by mediation, Engineer's action under Paragraph 10.05.C or a denial pursuant to Paragraphs 10.05.C.3 or 10.05.D shall become final and binding 30 days after termination of the mediation unless, within that time period, Owner or Contractor,

1. elects in writing to demand arbitration of the Claim, pursuant to Paragraph SC-16.02, or
2. agrees with the other party to submit the Claim to another dispute resolution process.

SC-16.02 Add a new paragraph immediately after Paragraph 16.01 that is to read as follows:

SC-16.02 *Arbitration*

A. All Claims or counter claims, disputes, or other matters in question between Owner and Contractor arising out of or relating to the Contract Documents or the breach thereof (except for Claims that have been waived by the making or acceptance of final payment as provided by Paragraph 14.09), including but not limited to those not resolved under the provisions of Paragraph SC-16.01.B and SC-16.01.C will be decided by arbitration in accordance with the Construction Industry Arbitration Rules of the American Arbitration Association, subject to the conditions and limitations of this Paragraph SC-16.02. This agreement to arbitrate and any other agreement or consent to arbitrate entered into will be specifically enforceable under the prevailing law of any court having jurisdiction.

B. The demand for arbitration will be filed in writing with the other party to the Contract and with the selected arbitrator or arbitration provider, and a copy will be sent to Engineer for information. The demand for arbitration will be made within the 30-day period specified in Paragraph SC-16.01.D. and in all other cases within a reasonable time after the Claim or counter claim, dispute, or other matter in question has arisen, and in no event shall any such demand be made after the date when institution of legal or equitable proceedings based on such Claim or counter claim, dispute, or other matter in question would be barred by the applicable statute of limitations.

C. No arbitration arising out of or relating to the Contract Documents shall include by consolidation, joinder, or in any other manner any

individual or entity (including Engineer, and the officers, directors, partners, employees, agents, or consultants of each and any of them) who is not party to this Contract unless:

1. the inclusion of such other individual or entity is necessary if complete relief is to be afforded among those who are already parties to the arbitration; and
2. such other individual or entity is substantially involved in a question of law or fact which is common to those who are already parties to the arbitration and which will arise in such proceedings, and

D. The award rendered by the arbitrator(s) shall be:

1. consistent with the agreement between the parties, and
2. in writing, and shall include:
  - a. a concise breakdown of the award, and
  - b. a written explanation of the award specifically citing the Contract Document provisions deemed applicable and relied on in making the award.

E. Subject to provisions of the Controlling Law relating to vacating or modifying an arbitration award, the award will be final. Judgment may be entered upon it in any court having jurisdiction thereof and it will not be subject to modification or appeal.

F. The fees and expenses of the arbitrator(s) and any arbitration service shall be shared equally by Owner and Contractor.

#### ARTICLE SC-18 – STATUTORY REQUIREMENTS

SC-18.01 This Article contains portions of certain Laws or Regulations which, by provision of Law or Regulations, are required to be included in the Contract Documents. The material included in this Article may not be complete or current. Contractor's obligation to comply with all Laws and Regulations applicable to the Work is set forth in Paragraph 6.09 of the General Conditions.

+ + END OF DOCUMENT + +

SECTION 01110

SUMMARY OF WORK

PART 1 – GENERAL

1.1 SECTION INCLUDES

A. Table of Articles for this Section is:

<u>Article</u>	<u>Title</u>
1.1	Section Includes
1.2	Location and Description of Work
1.3	Work By Others
1.4	Work By Owner
1.5	Sequence and Progress of Work
1.6	Contractor's Use of Site
1.7	Easements and Rights-of-Way
1.8	Notices to Owners and Authorities of Properties Adjacent to the Work
1.9	Salvage of Equipment and Materials
1.10	Partial Utilization by Owner

1.2 LOCATION AND DESCRIPTION OF WORK

A. The Work is located at the site of the Temple Water Treatment Plant located at 225 West Arrow Highway, Glendora, California.

B. The Work to be performed under this Contract includes, but is not limited to, constructing the Work described below and all related appurtenances. The Work shall be as follows:

1. Construction of subgrade concrete UV facility and wet well.
2. Construction of above grade masonry electrical room.
3. UV reactors with associated piping and appurtenances.
4. Five vertical turbine pumps with discharge piping and valves.
5. Relocation of an existing pump for temporary flow bypass.
6. Construction of a concrete chemical storage facility at grade.
7. Chemical metering pumps in both existing and new chemical facilities.
8. FRP and steel chemical tanks for storage of aluminum chlorohydrate solution and ammonia solution, respectively.
9. Site chemical piping and valves with analyzers and sample connections.
10. Self-priming backwash recycle pumps.
11. Grit chamber upstream of backwash clarifier.
12. Electrical service with transformer and switchboard outside.

13. Control panels and electrical equipment inside new electrical room.

C. Contracting Method: Work shall be constructed under one prime contract.

### 1.3 WORK BY OTHERS

A. Electrical service work shall be completed by Southern California Edison (SCE). CONTRACTOR shall coordinate with the utility company as required to complete the Work. CONTRACTOR shall complete all other Work as shown and/or specified.

SCE is expected to perform the following tasks:

1. Providing the material for the main electrical service conductors.
2. Pulling of electrical service conductors.
3. Termination of main service conductors
4. Supply and installation of the electrical transformer and meter.

### 1.4 WORK BY OWNER

A. Owner will perform the following in connection with the Work:

1. Operate all existing valves, gates, pumps, equipment, and appurtenances that will affect Owner's operation, unless otherwise specified or indicated.

### 1.5 SEQUENCE AND PROGRESS OF WORK

A. Requirements for sequencing and coordinating with Owner's operations, including maintenance of plant operations during construction, and requirements for tie-ins and shutdowns, are in Section 01143, Coordination with Owner's Operations.

### 1.5 CONTRACTOR'S USE OF SITE

- A. Contractor's use of the Site shall be confined to the areas shown.
- B. Move stored products that interfere with operations of Owner, other contractors, and others performing work for Owner.
- C. Limits on Contractor's use of the Site are confined to the immediate areas where Work is being performed and storage areas shown on the Contract Drawings.

### 1.6 EASEMENTS AND RIGHTS-OF-WAY

A. Easements and rights-of-way will be provided by Owner in accordance with the General Conditions. Confine construction operations within Owner's property, public rights-of-way, easements obtained by Owner, and the limits shown. Use care in placing construction tools, equipment, excavated materials, and materials and equipment to be incorporated into the Work to avoid damaging property and interfering with traffic. Do not enter private property outside the construction limits without permission from the owner of the property.



- B. Within Highway Rights-of-Way: Permits will be obtained by Owner, other than work permits to be obtained by Contractor. All Work performed and all operations of Contractor within the limits of highway rights-of-way shall conform to requirements of highway owner and applicable work permits, or authority having jurisdiction over right-of-way.

#### 1.7 NOTICES TO OWNERS AND AUTHORITIES OF PROPERTIES ADJACENT TO THE WORK

- A. Notify owners of adjacent property and utilities when prosecution of the Work may affect their property, facilities, or use of property.
- B. When it is necessary to temporarily obstruct access to property, or when utility service connection will be interrupted, provide notices sufficiently in advance to enable affected persons to provide for their needs. Conform notices to Laws and Regulations and, whether delivered orally or in writing, include appropriate information concerning the interruption and instructions on how to limit inconvenience caused thereby.
- C. Notify utility owners and other concerned entities at least 72 hours prior to cutting or closing streets or other traffic areas or excavating near Underground Facilities or exposed utilities.

#### 1.8 SALVAGE OF EQUIPMENT AND MATERIALS

- A. Existing equipment and materials removed and not shown or specified to be reused in the Work will become Contractor's property, except the following items that shall remain Owner's property:
  - 1. Chemical feed pumps.
- B. Existing equipment and materials removed by Contractor shall not be reused in the Work, except where so specified or indicated.
- C. Carefully remove in manner to prevent damage all equipment and materials specified or indicated to be salvaged and reused or to remain property of Owner. Store and protect salvaged items specified or indicated to be used in the Work. Replace in kind or with new items equipment, materials, and components damaged in removal, storage, or handling through carelessness or improper procedures.
- D. Contractor may furnish and install new items, with Engineer's approval, instead of those specified or indicated to be salvaged and reused, in which case such removed items will become Contractor's property.

#### 1.9 PARTIAL UTILIZATION BY OWNER

- A. Complete temporary bypass pump relocation and piping portion of the Work prior to Substantial Completion of the Contract. Substantially Complete this portion of the

Work by the Milestone specified in the Agreement, as applicable, in order that Owner may use the temporary bypass for the purpose of pumping finished water.

PART 2 – PRODUCTS (NOT USED)

PART 3 – EXECUTION (NOT USED)

++ END OF SECTION ++

## SECTION 01332

### SHOP DRAWING PROCEDURES

#### PART 1 - GENERAL

##### 1.1 DESCRIPTION

- A. The submittal of Shop Drawings shall conform to requirements of General Conditions and procedures described in this Section. A separate transmittal form shall be used for each specific item or class of material or equipment for which a submittal is required.
  
- B. The term “Shop Drawings” as used herein shall be understood to include detailed design calculations, fabrication and installation drawings, lists, graphs, test data, operating instructions, and other items which shall include, but are not necessarily limited to:
  - 1. Drawings and catalog information and cuts.
  - 2. Specifications, parts list, suggested spare parts lists, and equipment drawings.
  - 3. Wiring diagrams of systems and equipment.
  - 4. Complete lubrication, maintenance and operation instructions, including initial startup instructions as described in Section 01821, Instruction of Operations and Maintenance Personnel.
  - 5. Applicable certifications.
  - 6. Anchor bolt templates, mounting instructions and mounting design calculations as required.
  - 7. Required maintenance operations to allow all installed equipment to remain idle for a period of time not to exceed 24 months.
  - 8. Other technical, installation, and maintenance data as applicable.
  - 9. Unloading and handling methods and storage requirements.
  - 10. Note, highlight, and explain proposed changes to the Contract Documents.
  - 11. Paint submittal showing type of paint and the mils thickness of coating system used. The coating system shall be the approved system as submitted under Division 9, Finishes.
  - 12. Drawings showing CONTRACTOR field verifications illustrating all field dimensions. CONTRACTOR shall field verify all dimensions and existing materials shown on the Drawings. Any modifications required shall be at CONTRACTOR’S expense.

##### 1.2 PROCEDURE

- A. Submit Shop Drawings to 8001 Irvine Center Drive, Suite 1100, Irvine, CA 92618.
  
- B. A letter of transmittal shall accompany each submittal. If data for more than one Section of the Specifications is submitted, a separate transmittal letter shall accompany the data submitted for each Section.

- C. All letters of transmittal shall be submitted in duplicate.
- D. At the beginning of each letter of transmittal, provide a reference heading indicating the following:
  - 1. OWNER'S Name: Covina Irrigating Company
  - 2. Project Name: UV/Chloramines at Temple WTP
  - 3. Transmittal No.: \_\_\_\_\_
  - 4. Specification Section No.: \_\_\_\_\_
- E. If a Shop Drawing deviates from the requirements of the Contract Documents, CONTRACTOR shall specifically note each variation in his letter of transmittal.
- F. All Shop Drawings submitted for approval shall have a title block with complete identifying information satisfactory to ENGINEER.
- G. All Shop Drawings submitted shall bear the stamp of approval and signature of CONTRACTOR as evidence that they have been reviewed and verified to the completeness of the submittal by CONTRACTOR. Submittal without this stamp of approval will not be reviewed by ENGINEER and will be returned to CONTRACTOR. CONTRACTOR'S stamp shall contain the following minimum information:

Project Name: UV/Chloramines at Temple WTP  
 CONTRACTOR'S Name: \_\_\_\_\_  
 Date: \_\_\_\_\_

-----Reference-----

Item: \_\_\_\_\_  
 Specifications:  
     Section: \_\_\_\_\_  
     Page No.: \_\_\_\_\_  
     Para. No.: \_\_\_\_\_  
 Drawing No.: \_\_\_\_\_ of \_\_\_\_\_  
 Location: \_\_\_\_\_  
     Submittal No.: \_\_\_\_\_  
     Approved By: \_\_\_\_\_

- H. CONTRACTOR shall utilize the submittal identification numbering system as follows:
  - 1. The Submittal Number shall be a separate and unique number correlating to each individual submittal that is required to be tracked as a separate and unique

item. The Submittal Number shall be a two part, eight character, alpha/numeric number assigned by CONTRACTOR in the following manner:

- a. The first part of the Submittal Number shall consist of five characters that pertain to the applicable Specification Section number.
  - b. The second part of the Submittal Number shall consist of three digits (numbers 001 to 999) to number each separate and unique submittal submitted under each Specification Section.
  - c. A dash shall separate the two parts of the Submittal Number.
  - d. A typical Submittal Number for the third Working Drawing submitted under Section 15101, Ductile Iron Pipe, would be 15101-003.
2. The Review Cycle shall be a three-digit number indicating the initial submission or resubmission of the same submittal. For example:

001 = First (initial) submission.  
002 = Second submission (first resubmission).  
003 = Third submission (second resubmission).

3. An example of the typical submittal identification numbers for the first submission of the third submittal submitted under Section 15101, Ductile Iron Pipe is:

<u>Submittal Number</u>	<u>Review Cycle</u>
15101-003	001

An example of the typical submittal identification numbers for the second submission of the third submittal submitted under Section 15101, Ductile Iron Pipe is:

<u>Submittal Number</u>	<u>Review Cycle</u>
15101-003	002

- I. CONTRACTOR shall initially submit to ENGINEER a minimum of six (6) copies of all submittals that are on 11-inch by 17-inch or smaller sheets, and one unfolded reproducible and 6 prints made from that reproducible for all submittal on sheets larger than 11-inch by 17-inch.
- J. After ENGINEER completes his review, Shop Drawings will be affixed with a stamp and marked with one of the following notations:
  1. Approved.
  2. Approved as Corrected.
  3. Approved as Corrected, Resubmit.
  4. Revise and Resubmit.
  5. Not Approved.
  6. Not Reviewed.
  7. For Information Only.

- K. If a submittal is acceptable, it will be marked “Approved” or “Approved as Corrected”. Two prints or copies of the submittal will be returned to CONTRACTOR.
- L. Upon return of a submittal marked “Approved” or “Approved as Corrected”, CONTRACTOR may order, ship or fabricate the materials included on the submittal, provided it is in accordance with the corrections indicated.
- M. If a Shop Drawing marked “Approved as Corrected” has extensive corrections or corrections affecting other Shop Drawings or Work, ENGINEER may require that CONTRACTOR make the corrections indicated thereon and resubmit the Shop Drawings for record purposes. Such Shop Drawings will have the notation, “Approved as Corrected - Resubmit.” The corrected Shop Drawing shall be a pre-condition for payment for the work item of the Shop Drawing.
- N. If a submittal is unacceptable, two (2) copies will be returned to CONTRACTOR with one of the following notations:
  - 1. “Revise and Resubmit”.
  - 2. “Not Approved”.
- O. Upon return of a submittal marked “Revise and Resubmit”, CONTRACTOR shall make the corrections indicated and repeat the initial approval procedure. The “Not Approved” notation is used to indicate material or equipment that is not acceptable. Upon return of a submittal so marked, CONTRACTOR shall repeat the initial approval procedure utilizing acceptable material or equipment.
- P. Shop Drawings shall be submitted well in advance of the need for the material or equipment for construction and with ample allowance for the time required to make delivery of material or equipment after data covering such is approved. CONTRACTOR shall assume the risk for all Work, materials or equipment that are fabricated, delivered or installed prior to the approval of Shop Drawings. Materials or equipment will not be included in periodic progress payments until approval thereof has been obtained in the specified manner.
- Q. ENGINEER will review and process all submittals promptly; a reasonable time shall be allowed for this, for the Shop Drawings being revised and resubmitted, and for time required to return the approved Shop Drawings to CONTRACTOR.
- R. It is CONTRACTOR’S responsibility to review submittals made by his suppliers and subcontractors before transmitting them to the ENGINEER to assure proper coordination of the Work and to determine that each submittal is in accordance with CONTRACTOR’S desires and that there is sufficient information about materials and equipment for ENGINEER to determine compliance with the Contract Documents. Incomplete or inadequate submittals will be returned for revision without review.

- S. CONTRACTOR shall furnish required submittals with complete information and accuracy in order to achieve required approval of an item within two submittals. OWNER reserves the right to backcharge CONTRACTOR, for ENGINEER'S costs for resubmittals that account for a number greater than 20 percent of the total number of first time submittals. OWNER reserves the right to backcharge CONTRACTOR for all third submittals. The number of first time submittals shall be equal to the number of submittals agreed to by ENGINEER and CONTRACTOR in accordance with Section 01330.1.2.A.2. All costs to ENGINEER involved with subsequent submittal of Shop Drawings, Samples or other items requiring approval will be backcharged to CONTRACTOR at the rate of 3.0 times direct technical labor cost by deducting such costs from payments due CONTRACTOR for Work completed. In the event that CONTRACTOR requests a substitution for a previously approved item, all of ENGINEER'S costs in the reviewing and approval of the substitution will be backcharged to CONTRACTOR, unless the need for such substitution is beyond the control of CONTRACTOR.
- T. Mark each page of a submittal and each individual component submitted with the specification number, paragraph, and subparagraph. Arrange submittal information presentation to appear in the sequence in the Specification Section.

PART 2 - PRODUCTS (NOT USED)

PART 3 - EXECUTION (NOT USED)

++ END OF SECTION ++

## SECTION 01320

### PROGRESS SCHEDULE

#### PART 1 - GENERAL

##### 1.1 DESCRIPTION

- A. Provide Progress Schedule conforming to the requirements below, unless otherwise approved by ENGINEER.
- B. Update Progress Schedules every month, unless otherwise specified or directed by ENGINEER.
- C. ENGINEER's acceptance of the Progress Schedule, and comments or opinions concerning the various schedule documents and reports shall not control the CONTRACTOR's independent judgment concerning means, methods, techniques, sequences and procedures of construction. CONTRACTOR is solely responsible for meeting the Contract Times.

##### 1.2 CONTENT

- A. Shop Drawing submittal dates and required approval dates.
- B. Product delivery dates.
- C. Factory and field-testing dates.
- D. Dates for beginning and completing each phase of the Work by Activity and by trades.

##### 1.3 FORMAT

- A. Type: Horizontal bar chart.
- B. Sheet Size: 24-inches by 36-inches.
- C. Time Scale: Indicate first date of each work week.
- D. Organization:
  - 1. Group Shop Drawing submittals and reviews into a separate subschedule.
  - 2. Group product deliveries into a separate subschedule.
  - 3. Group construction into a separate subschedule by activity.
  - 4. Group critical activities, that dictate the rate of progress into a separate subschedule.
  - 5. Organize each subschedule by Specification Section number.



E. Activity Designations: Show title and related Specification Section number.

#### 1.4 SUBMITTALS

- A. Submit preliminary Progress Schedule in accordance with Paragraph 2.05 and the General Conditions.
- B. Submit updated Progress Schedules at progress meetings. If a Progress Schedule remains unchanged from one period to the next, submit a written notice to that effect.
- C. Unless otherwise specified, submit four copies of each Progress Schedule. One copy will be reviewed by the ENGINEER and returned. The other copies will be retained by the ENGINEER.
- D. Attach a letter of transmittal to each submittal and include the following information in the letter:
  - 1. A listing of items, which have changed since the last submittal.
  - 2. Discussion of problems causing delays, anticipated length of delays, and proposed countermeasures.

#### PART 2 - PRODUCTS (Not Used)

#### PART 3 - EXECUTION (Not Used)

++ END OF SECTION ++

## SECTION 01312

### PROGRESS MEETINGS

#### PART 1 – GENERAL

##### 1.1 DESCRIPTION

- A. Scope:
1. Progress meetings will be held throughout the Project. CONTRACTOR shall attend each progress meeting prepared to discuss in detail all items on the agenda.
  2. ENGINEER will preside at progress meetings and will prepare and distribute minutes of progress meetings to all meeting participants and others as requested.
- B. Date and Time:
1. Regular Meetings: Every two weeks on a day and time agreeable to OWNER, ENGINEER, and CONTRACTOR.
  2. Other Meetings: As required.
- C. Place: CONTRACTOR's field office at the Site or other location mutually agreed upon by OWNER, CONTRACTOR, and ENGINEER.
- D. Handouts: CONTRACTOR shall bring to each progress meeting a minimum of six copies of each of the following:
1. List of Work accomplished since the previous progress meeting.
  2. Up-to-date Progress Schedule.
  3. Up-to-date Schedule of Submittals.
  4. Detailed "look-ahead" schedule of Work planned through the next progress meeting, with specific starting and ending dates for each activity, including shutdowns, deliveries of important materials and equipment, Milestones (if any), and important activities affecting the OWNER, Project, and Site.
  5. When applicable, list of upcoming, planned time off (with dates) for personnel with significant roles on the Project, and the designated contact person in their absence.

##### 1.2 REQUIRED ATTENDANCE

- A. Representatives present for each entity shall be authorized to act on that entity's behalf.
- B. Required Attendees:

1. CONTRACTOR:
  - a. Project manager.
  - b. Site superintendent.
  - c. Safety representative.
  - d. When needed for the discussion of a particular agenda item, representatives of Subcontractors and Suppliers shall attend meetings.
2. ENGINEER:
  - a. Project manager or designated representative
  - b. Resident Project Representative (if any).
  - c. Others as required by ENGINEER.
3. OWNER's representative(s), as required.
4. Testing and inspection agencies, as required.
5. Others, as appropriate.

### 1.3 AGENDA

- A. Preliminary Agenda: Be prepared to discuss in detail the topics listed below. Revised agenda, if any, will be furnished to CONTRACTOR prior to first progress meeting. Progress meeting agenda may be modified by ENGINEER during the Project as required.
  1. Review, comment, and amendment (if required) of minutes of previous progress meeting.
  2. Review of progress since the previous progress meeting.
  3. Planned progress through next progress meeting.
  4. Review of Progress Schedule
    - a. Contract Times, including Milestones (if any)
    - b. Critical path.
    - c. Schedules for fabrication and delivery of materials and equipment.
    - d. Corrective measures, if required.
  5. Submittals:
    - a. Review of status of critical submittals.
    - b. Review revisions to Schedule of Submittals.
  6. Contract Modifications
    - a. Requests for interpretation
    - b. Clarification notices
    - c. Field Orders
    - d. Proposal requests
    - e. Change Order proposals
    - f. Work Change Directives.
    - g. Change Orders.
    - h. Claims.
  7. Applications for progress payments.
  8. Problems, conflicts, and observations.
  9. Quality standards, testing, and inspections.
  10. Coordination between parties.

11. Site management issues, including access, security, maintenance and protection of traffic, maintenance, cleaning, and other Site issues.
12. Safety.
13. Permits.
14. Construction photographic documentation.
15. Record documents status.
16. Punch list status, as applicable.
17. Other business.

PART 2 – PRODUCTS (NOT USED)

PART 3 – EXECUTION (NOT USED)

++ END OF SECTION ++

## SECTION 01310

### PROJECT COORDINATION

#### PART 1 – GENERAL

##### 1.1 DESCRIPTION

- A. CONTRACTOR shall coordinate the Work, including testing agencies, Subcontractors, Suppliers, and others with whom coordination is necessary, in accordance with the General Conditions, Supplementary Conditions, and this Section, to complete the Work within the Contract Times.
- B. In accordance with the General Conditions, CONTRACTOR shall cooperate with and coordinate the Work with other contractors, utility service companies, OWNER's employees working at the Site, and other entities working at the Site, in accordance with Section 01110, Summary of Work.
- C. CONTRACTOR will not be responsible or liable for damage unless it is through negligence of CONTRACTOR, or his Subcontractors, Supplier, or other entity employed by CONTRACTOR.
- D. Attend and participate in all project coordination and progress meetings, and report on the progress of all Work and compliance with the Progress Schedule.
- E. Maintain sufficient competent personnel, drafting and CADD equipment, and supplies at the Site for preparing layout drawings, coordination drawings, and record drawings. With the Contract Documents and Shop Drawings, use these drawings as a tool for coordinating the Work of various trades. Where such drawings are to be prepared by mechanical, electrical, plumbing, or heating and ventilating Subcontractors, ensure that each Subcontractor maintains required personnel and facilities at the Site.

#### PART 2 – PRODUCTS (NOT USED)

#### PART 3 – EXECUTION (NOT USED)

++ END OF SECTION ++

## SECTION 01291

### SCHEDULE OF VALUES

#### PART 1 – GENERAL

##### 1.1 DESCRIPTION

- A. Submit to ENGINEER for acceptance a Schedule of Values that allocates cost to each item of the Work. Schedule of Value list of line items shall correspond to each aspect of the Work, establishing in detail the portion of the Contract Price allocated to each major component of the Work.
- B. Upon request of ENGINEER, support values with data that substantiate their correctness.
- C. Submit preliminary Schedule of Values to ENGINEER for initial review. CONTRACTOR shall incorporate ENGINEER's comments into the Schedule of Values and resubmit to ENGINEER. ENGINEER may require corrections and re-submittals until Schedule of Values is acceptable.
- D. Schedule of Values and the Progress Schedule updates specified in Section 01320, Progress Schedule, shall be basis for preparing each Application for Payment. Schedule of Values may be used as a basis for negotiating price of changes, if any, in the Work.
- E. Include in Schedule of Values unit price payment items with their associated quantity. Provide in the Schedule of Values detailed breakdown of unit prices when required by ENGINEER.
- F. Requirements for preliminary Schedule of Values and Schedule of Values are:
  - 1. Schedule of Values shall show division of Work between CONTRACTOR and Subcontractors. Line items for Work to be done by Subcontractor shall include the word, "(SUBCONTRACTED)".
  - 2. Schedule of Values shall include breakdown of costs for materials and equipment, installation, and other costs used in preparing the Bid by CONTRACTOR and each Subcontractor. List purchase and delivery costs for materials and equipment for which CONTRACTOR may apply for payment as stored materials.
  - 3. Include separate amounts for each Specification Section in the Contract Documents by structure, building, and work area.

4. Identify each line item with number corresponding to the associated Specification Section number. List sub-items of major products or systems, as appropriate or when requested by ENGINEER.
5. Sum of individual values shown on the Schedule of Values shall equal the total of associated payment item. Sum of payment item totals in the Schedule of Values shall equal the Contract Price.
6. Include in each line item a directly proportional amount of CONTRACTOR's overhead and profit. Do not include overhead and profit as separate item(s).
7. Include separate line item for each allowance, and for each unit price item
8. Include line item for bonds and insurance in payment item for Item 1, in amount not exceeding 5.0 percent of the Contract Price. This may be applied for in the first Application for Payment.
9. Include items for the General Conditions, permits (when applicable), construction Progress Schedule, and other items required by ENGINEER. Include such items in Applications for Payment on schedule accepted by ENGINEER
10. Line items for Site maintenance such as dust control, compliance with storm water pollution prevention plans and permits, spill prevention control and countermeasures plans, and for construction photographic documentation; temporary utilities and temporary facilities, field offices, temporary controls, field engineering, and similar Work shall be included in the Schedule of Values and proportioned in Applications for Payment throughout duration of the Work.
11. Include separate line items under each appropriate payment item for mobilization and demobilization. Document for ENGINEER the activities included in mobilization and demobilization line items.
  - a. Mobilization will be limited to 2.0 percent of the Contract Price, and will be paid in four payments, each of 25 percent of total amount for mobilization.
  - b. Demobilization shall be at least 1.0 percent of the Contract Price and shall be included with the Application for Payment following Substantial Completion, or other schedule accepted by ENGINEER.
13. Costs for submittals, operations and maintenance manuals, field testing, and training of operations and maintenance personnel shall be as follows, unless otherwise accepted by ENGINEER:
  - a. Up to eight percent of cost (including overhead and profit) of each equipment item, exclusive of transportation and installation costs associated with that item, may be allocated to preparation of submittals and may be included in the Application for Payment following ENGINEER's approval of Shop Drawings (and acceptance of other submittals, as applicable) required for fabricating or purchasing for that item for the Work.

- b. Up to three percent of total cost of each item (including overhead and profit), including materials and equipment, and installation, may be apportioned to testing and included in the Application for Payment following ENGINEER's acceptance of the associated written Site testing report(s).
  - c. Up to a total of four percent of equipment cost (including overhead and profit), exclusive of transportation and installation costs, may be apportioned to operations and maintenance manuals and training of operations and maintenance personnel, which may be included in the Application for Payment following completion of training for that item.
- 14. Schedule of Values shall include an itemized list of Work by work area, as applicable, for Work included in Section 01143, Coordination with Owner's Operations.
  - 15. Submit Schedule of Values on 8.5-inch by 11-inch white paper, using the continuation sheets of the Application for Payment form specified in Section 01297, Progress Payment Procedures.
  - 16. Coordinate Schedule of Values with resource loading and cost loading of the Progress Schedule, in accordance with Section 01322, Progress Schedule.

## 1.2 SUBMITTALS

- A. Informational Submittals: Submit the following:
  - 1. Submit to ENGINEER five copies of Schedule of Values.
  - 2. Content of Schedule of Values submittals shall conform to Article 1.1 of this Section.
  - 3. Time Frames for Submittals:
    - a. Submit preliminary Schedule of Values within time frame specified in the General Conditions.
    - b. Submittal of the Schedule of Values shall be in accordance with the General Conditions. ENGINEER will not accept Applications for Payment without an acceptable Schedule of Values.
    - c. When required by ENGINEER, promptly submit updated Schedule of Values to include cost breakdowns for changes in the Contract Price.

## PART 2 – PRODUCTS (NOT USED)

## PART 3 – EXECUTION (NOT USED)

++ END OF SECTION ++



## SECTION 01271

### MEASUREMENT AND PAYMENT

#### PART 1 - GENERAL

##### 1.1 DESCRIPTION

- A. The items listed below beginning with Article 1.5, refer to and are the same pay items listed in the Bid Form. They constitute all pay items for completing the Work. No direct or separate payment will be made for providing miscellaneous temporary or accessory works, plant services, CONTRACTOR's or ENGINEER's field offices, layout surveys, Project signs, sanitary requirements, testing, safety devices, submittals and record drawings, water supplies, power and fuel, traffic maintenance, removal of waste, security, coordination with OWNER's operations, bonds, insurance, or all other requirements of the General Conditions, Supplementary Conditions, General Requirements, and other requirements of the Contract Documents. Compensation for all services, items, and products shall be included in prices stipulated for lump sum and unit price pay items listed in this Section and included in the Contract.
- B. Each lump sum and unit price will be deemed to include an amount considered by CONTRACTOR to be adequate to cover CONTRACTOR's overhead and profit for each separately identified item.

##### 1.2 ENGINEER'S ESTIMATE OF QUANTITIES

- A. ENGINEER's estimated quantities for unit price items, as listed in the Bid Form, are approximate only and are included solely for purpose of comparing Bids. OWNER does not expressly or by implication agree that nature of materials encountered below ground surface or actual quantities of material encountered or required will correspond with quantities on the Bid Form and reserves right to increase or decrease quantities or to eliminate quantities as OWNER may deem necessary. Except as provided in Article 1.3 of this Section, CONTRACTOR or OWNER will not be entitled to adjustment in unit bid price as a result of change in estimated quantity and agrees to accept the unit bid prices as complete and total compensation for additions caused by changes or alterations in the Work directed by OWNER.

##### 1.3 ADJUSTMENT OF UNIT PRICES FOR INCREASE OR DECREASE OF ESTIMATED QUANTITIES

- A. For items paid on a unit price basis, increases or decreases in the quantity of an item of Work will be determined by comparing total payable quantity of Work with ENGINEER's estimated quantity shown in the Bid Form.

- B. Notwithstanding other provision of the Contract Documents, if total payable quantity of unit price item of Work that has an as-bid computed total value of five percent or more of the sum of the as-bid computed total values of all items bid, varies from ENGINEER's estimated of quantity by more than 25 percent above or below ENGINEER's estimated quantity, unit price of that item will be subject to review by ENGINEER. If warranted, an equitable adjustment will be made by Change Order to credit OWNER with reduction in cost or compensate CONTRACTOR for increase in cost resulting from the change in quantity. The unit price adjustment, if any, will be based on cost increase or decrease due solely to variation above 125 percent or below 75 percent of ENGINEER's estimated quantity.
- C. ENGINEER's review for possible unit price cost adjustment will be made at time ENGINEER deems reasonable and proper.
- D. Payment for unit price item of Work that has an as-bid computed total value of less than five percent of the sum of the as-bid computed total values of all items bid will be made at the unit price bid, regardless of an increase or decrease in quantity.

#### 1.4 RELATED PROVISIONS

- A. Payments to CONTRACTOR: Refer to General Conditions, Supplementary Conditions, and Agreement.
- B. Changes in Contract Price: Refer to General Conditions and Supplementary Conditions.
- C. Schedule of Values: Refer to General Conditions, Supplementary Conditions, and Section 01291, Schedule of Values.

#### 1.5 BID ITEMS

- A. Item 1 - General Construction:
  - 1. Measurement: Furnish all labor, materials, and equipment necessary for the construction of the facilities complete and operational, in accordance with the Contract Documents. This item includes all work as specified in the Contract Documents but not specifically described in Bid Items 2 through 5. In addition, the CONTRACTOR's attention is directed to the specific construction requirements, which include but are not limited to the following:
    - a. Facility Tie-ins and Shutdowns.
    - b. Protection of existing structures and utilities, including relocation or rerouting of utilities, protection of service to utilities
    - c. Pipeline Testing.
    - d. Pre-cast vault construction and installation
    - e. Operation and Maintenance Manuals
    - f. Training of CIC Personnel
    - g. Commissioning
    - h. Chemical feed and sample piping, and analyzers.

- i. Demolition of existing structures and equipment.
    - j. All other items not specifically described in other pay items, including but not limited to the following:
      - i. Structural
      - ii. Architectural
      - iii. Civil
      - iv. HVAC
      - v. Process Mechanical Piping
      - vi. Electrical
      - vii. Instrumentation
  2. Payment: The lump sum payment for this item will be full compensation for providing all general construction complete as specified in the Contract Documents.
- B. Item 2 – UV Equipment:
  1. Measurement and Payment: Purchase and delivery of UV equipment in accordance with Section 11461 and Attachment A to this Section. Bidder shall include within his lump sum bid amount the pre-negotiated price for the purchase of new Ultraviolet Disinfection Equipment from the listed vendor as described in Section 11461 of the Specifications. Attachment A of this Section includes pre-negotiated pricing and scope of supply as well as commercial terms and conditions of sale provided by listed vendor. The attachments are not intended as a substitute for submittal requirements per the Contract Documents. The CONTRACTOR is responsible for providing any taxes/fees, material and services including any and all that may not be included in listed vendor's negotiated price.
- C. Item 3 – Site Paving:
  1. Measurement: Furnish all labor, materials and equipment necessary for all pavement resurfacing, repair and restoration of excavated or damaged areas caused in the course of construction of the Work as specified in the Contract Documents. This item shall also include all new pavement work as specified in the Contract Documents.
  2. Payment: The unit price payment for this item will be full compensation for providing AC Pavement work complete as specified in the Contract Documents.
- D. Item 4 – Site Fencing:
  1. Measurement: Furnish all labor, materials and equipment necessary for replacement of site fencing and gates as specified in the Contract Documents. This item shall include demolition of existing fencing and gates and installation of new fencing and gates as specified in the Contract Documents.
  2. Payment: The unit price payment for this item will be full compensation for replacing fencing and gates complete as specified in the Contract Documents.
- E. Item 5 – Suburban Water Systems Facilities Improvements

1. Measurement: Furnish all labor, materials and equipment necessary for improvements to the Suburban Water Systems facilities, as specified in the Contract Documents. This item shall include relocation of High Head Pump T-1, demolition of existing Low Head Pump D-1, installation of existing Pump T-1 in existing pump can, furnishing and installation of the Suburban Bypass Line including valves and flow meters, furnishing and installation of new T-1 pump, VFD, and discharge piping, and all associated electrical and instrumentation cable and conduit as specified in the Contract Documents.
2. Payment: The unit price payment for this item will be full compensation for improvements to the Suburban Water Systems facilities complete as specified in the Contract Documents.

PART 2 - PRODUCTS (NOT USED)

PART 3 - EXECUTION (NOT USED)

++ END OF SECTION ++

## SECTION 01420

### REFERENCES

#### PART 1 – GENERAL

##### 1.1 DEFINITIONS

- A. Definitions and terminology applicable to all the Contract Documents are included in the General Conditions and Supplementary Conditions.
- B. Terminology used in the Specifications includes:
  - 1. Indicated: Refers to graphic representations, notes, or schedules on the Drawings, or to other paragraphs or schedules in the Specifications and similar locations in the Contract Documents. Terminology such as “shown”, “noted”, “scheduled”, and “specified” are used to help the user locate the reference without limitation on the location.
  - 2. Installer, applicator, or erector: CONTRACTOR or another entity engaged by CONTRACTOR, either as an employee or Subcontractor, to perform a particular construction activity, including installation, erection, application or similar Work. Installers shall be experienced in the Work they are engaged to perform.
    - a. The term “experienced”, when used with the term “installer” means having successfully completed a minimum of five previous projects similar in size and scope to this Project; being familiar with the special requirements indicated; and having complied with the requirements of authorities having jurisdiction and of the Supplier of the material or equipment being installed.
  - 3. Trades: Use of a term such as “carpentry” does not imply that certain construction activities must be performed by accredited or unionized individuals of a corresponding generic name, such as “carpenter”, unless otherwise indicated in the Contract Documents or required by Laws or Regulations. Such terminology also does not imply that specified requirements apply exclusively to trade personnel of the corresponding generic name.
  - 4. Assigned Specialists: Certain Sections of the Specifications require that specific construction activities be performed by specialists recognized as experts in those operations. Engage said specialists for those activities, and their engagement is a requirement over which CONTRACTOR has no option. These requirements do not conflict with enforcement of building codes and other Laws and Regulations. Also, they are not intended to interfere with local trade union jurisdictional settlements and similar conventions. Such assignments shall not relieve CONTRACTOR of responsibility for fulfilling requirements of the Contract Documents.

## 1.2 APPLICABLE CODES

- A. References in the Contract Documents to local code(s) shall mean the following:
1. California Building Code, 2007.
  2. City of Glendora Municipal Code
  3. National Electric Code.
  4. NFPA 101, Life Safety Code.

## 1.3 ABBREVIATIONS

- A. Common abbreviations that may be found in the Contract Documents are listed below, alphabetically by their written-out meaning:

alternating current		a-c
ampere		A
ante meridian		a.m.
average		avg
biochemical oxygen demand		BOD
brake horsepower		bhp
British thermal unit		Btu
Centigrade (or Celsius)		C
chlorinated polyvinyl chloride		CPVC
cubic inch		cu in
cubic foot		cu ft
cubic yard		cu yd
cubic feet per minute		cfm
cubic feet per second		cfs
decibel		db
degree Centigrade (or Celsius)	(Write)	degrees C or °C
degree Fahrenheit (Write)		degrees F or °F
diameter		dia
direct current		d-c
dollars		\$
each		ea
efficiency		eff
Fahrenheit		F
feet per hour		fph
feet		ft

feet per minute	ftm
feet per second	fps
figure	Fig
flange	flg
foot-pound	ft-lb
gallon	gal
gallons per hour	gph
gallons per minute	gpm
gallons per second	gps
gram	g
grams per liter	g/L
Hertz	Hz
horsepower	hp
hour	hr
inch	in.
inches water gauge	in. w.g.
inch-pound	in.-lb
inside diameter	ID
thousand pounds	kips
thousand pounds per square inch	ksi
kilovolt-ampere	kva
kilowatt	kw
kilowatt-hour	kwhr
linear foot	lin ft
liter	L
maximum	max
mercury	Hg
milligram	mg
milligrams per liter	mg/l or mg/L
milliliter	ml
millimeter	mm
million gallons per day	mgd
million gallon	MG
minimum	min
National Pipe Threads	NPT
net positive suction head	NPSH

number	no.
ounce	oz
ounce-force	ozf
outside diameter	OD
parts per hundred	pph
parts per million	ppm
polyvinyl chloride	PVC
post meridian	p.m.
pound	lb
pounds per square inch	psi
pounds per square inch absolute	psia
pounds per square inch gage	psig
pounds per square foot	psf
revolutions per minute	rpm
second	sec
specific gravity	sp gr
square	sq
square foot	sq ft
square inch	sq in.
square yard	sq yd
standard	std
standard cubic feet per minute	scfm
total dynamic head	TDH
totally-enclosed-fan-cooled	TEFC
volt	V
volts alternating current	vac
volts direct current	vdc

#### 1.4 REFERENCE STANDARDS

- A. Refer to Article 3 of the General Conditions, as may be modified by the Supplementary Conditions, relative to reference standards and resolving discrepancies between reference standards and Contract Documents. Provisions of reference standards are in effect as specified in the Specifications.
- B. Copies of Standards: Each entity engaged in the Work shall be familiar with reference standards applicable to its construction activity. Copies of applicable reference standards are not bound with the Contract Documents. Where reference



standards are needed for a construction activity, obtain copies of standards from the publication source.

- C. Abbreviations and Names: Where reference standards, specifications, codes, manuals, Laws or Regulations, or other published data of international, national, regional or local organizations are referred to in the Contract Documents, the organization issuing the standard may be referred to by their acronym or abbreviation only. Following acronyms or abbreviations that may appear in the Contract Documents shall have the meanings indicated below. Listing is alphabetical by acronym.

AA	Aluminum Association
AABC	Associated Air Balance Council
AAMA	American Architectural Manufacturers Association
AASHTO	American Association of State Highway and Transportation Officials
ACI	American Concrete Institute
ACS	American Chemical Society
AEIC	Association of Edison Illuminating Companies
AF&PA	American Forest and Paper Association
ABMA	American Bearing Manufacturers Association (formerly Anti-Friction Bearing Manufacturers' Association (AFBMA))
AGMA	American Gear Manufacturers Association
AI	Asphalt Institute
AIChE	American Institute of Chemical Engineers
AISC	American Institute of Steel Construction
AISI	American Iron and Steel Institute
AITC	American Institute of Timber Construction
ALSC	American Lumber Standards Committee
AMA	Acoustical Materials Association
AMCA	Air Movement and Control Association
ANSI	American National Standards Institute
APA	The Engineered Wood Association
API	American Petroleum Institute
APHA	American Public Health Association
AREA	American Railway Engineering Association
ARI	Air Conditioning & Refrigeration Institute
ASAE	American Society of Agricultural Engineers
ASCE	American Society of Civil Engineers
ASHRAE	American Society of Heating, Refrigerating and Air Conditioning Engineers

	Engineers
	Conditioning
ASME	American Society of Mechanical Engineers
ASNT	American Society for Non-Destructive Testing
ASTM	American Society for Testing and Materials
AWCI	Association of the Wall and Ceiling Industry
AWI	Architectural Woodwork Institute
AWPA	American Wood Protection Association
AWPI	American Wood Preservers Institute
AWS	American Welding Society
AWWA	American Water Works Association
BAAQMD	Bay Area Air Quality Management District
BHMA	Builders Hardware Manufacturers Association
BIA	Brick Industry Association
CBMA	Certified Ballast Manufacturers Association
CDA	Copper Development Association
CGA	Compressed Gas Association
CISCA	Ceilings and Interior Systems Construction Association
CISPI	Cast Iron Soil Pipe Institute
CMAA	Crane Manufacturers Association of America
CRSI	Concrete Reinforcing Steel Institute
DIN	Deutsches Institut für Normung eV (German Institute for Standardization)
DIPRA	Ductile Iron Pipe Research Association
EJMA	Expansion Joint Manufacturers Association, Inc.
ETL	Intertek Testing Services, Inc. (formerly ETL Testing Laboratories, Inc.)
FCC	Federal Communications Commission
FEMA	Federal Emergency Management Agency
FM	Factory Mutual (FM Global)
FS	Federal Specification
GA	Gypsum Association
GANA	Glass Association of North America
HEW	Department of Health, Education and Welfare
HI	Hydraulic Institute
HMI	Hoist Manufacturers Institute
HUD	Department of Housing and Urban Development
ICC	International Code Council

ICEA	Insulated Cable Engineers Association
IEEE	Institute of Electrical and Electronics Engineers
IESNA	Illuminating Engineering Society of North America
IFI	Industrial Fasteners Institute
IRI	Industrial Risk Insurers
ISA	Instrumentation, Systems, and Automation Society (formerly Instrument Society of America)
ISO	Insurance Services Office
ISO	International Organization for Standardization
LEED	Leadership in Energy and Environmental Design (USGBC)
LPI	Lightning Protection Institute
MIA	Marble Institute of America
ML/SFA	Metal Lath/Steel Framing Association
MS	Military Specifications
MSS	Manufacturers' Standardization Society
MMA	Monorail Manufacturers Association
NAAMM	National Association of Architectural Metal Manufacturers
NACE	National Association of Corrosion Engineers
NAPF	National Association of Pipe Fabricators, Inc.
NARUC	National Association of Regulatory Utilities Commissioners
NBHA	National Builders Hardware Association
NCMA	National Concrete Masonry Association
NEC	National Electric Code
NELMA	Northeastern Lumber Manufacturers' Association
NEMA	National Electrical Manufacturers Association
NESC	National Electric Safety Code
NETA	International Electrical Testing Association
NFPA	National Fire Protection Association
NFRC	National Fenestration Rating Council
NGA	National Glass Association
NHLA	National Hardwood Lumber Association
NHPMA	Northern Hardwood and Pine Manufacturers Association
NIST	United States Department of Commerce, National Institute of Standards and Technology
NLGA	National Lumber Grades Authority
NRCA	National Roofing Contractors Association
NRMCA	National Ready Mixed Concrete Association
NSF	National Sanitation Foundation

NSSGA	National Stone, Sand, and Gravel Association
NTMA	National Terrazzo and Mosaic Association
OSHA	Occupational Safety and Health Administration
PCA	Portland Cement Association
PCI	Precast/Prestressed Concrete Institute
PEI	Porcelain Enamel Institute
PFI	Pipe Fabrication Institute
PPI	Plastics Pipe Institute
PGMC	Primary Glass Manufacturers Council
PS	Product Standards Section, United States Department of Commerce
RCSC	Research Council on Structural Connections (part of AISC)
RMA	Rubber Manufacturers Association
SAE	Society of Automotive Engineers
SCAQMD	Southern California Air Quality Management District
SCPRF	Structural Clay Products Research Foundation
SDI	Steel Deck Institute
SDI	Steel Door Institute
SIGMA	Sealed Insulating Glass Manufacturing Association
SJI	Steel Joist Institute
SMACNA	Sheet Metal and Air Conditioning Contractor's National Association
SPI	Society of the Plastics Industry
SPIB	Southern Pine Inspection Bureau
SSPC	Society for Protective Coatings
SWI	Steel Window Institute
TEMA	Tubular Exchanger Manufacturers Association
TCNA	Tile Council of North America
UL	Underwriters Laboratories, Inc.
USEPA	United States Environmental Protection Agency
USGBC	United States Green Building Council
USGS	United States Geological Survey
USPHS	United States Public Health Service
WCLIB	West Coast Lumber Inspection Bureau
WDMA	Window and Door Manufacturers Association
WWEMA	Water and Wastewater Equipment Manufacturers Association
WWPA	Western Wood Products Association

PART 2 – PRODUCTS (NOT USED)

PART 3 – EXECUTION (NOT USED)

++ END OF SECTION ++

# COVINA IRRIGATING COMPANY

## TEMPLE WATER TREATMENT PLANT UV/CHLORAMINES PROJECT

PROJECT LOCATION

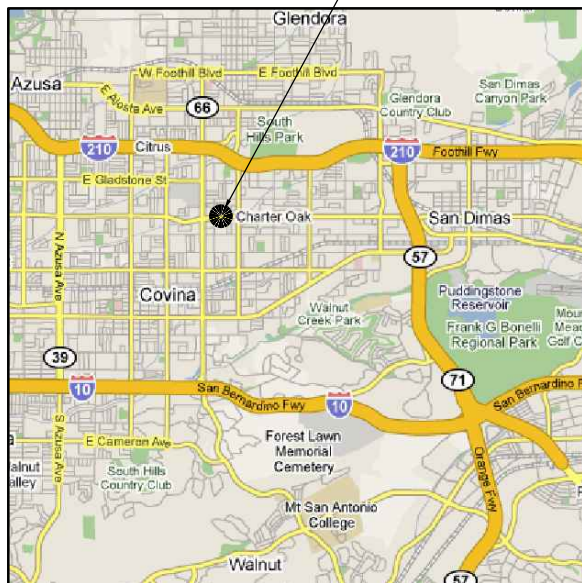

VICINITY MAP  
NOT TO SCALE

WILLIAM B. TEMPLE WTP  
255 W. ARROW HWY.  
GLENDDORA, CA

TEMPLE WTP

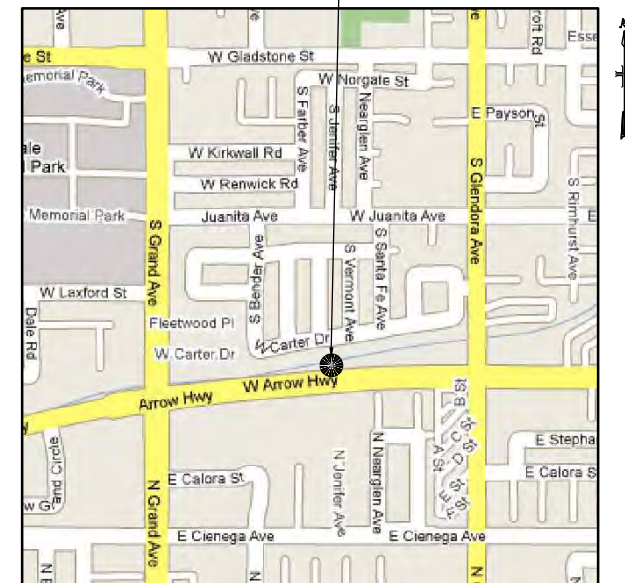

LOCATION MAP  
NOT TO SCALE



### DECEMBER 2009

COVINA IRRIGATING COMPANY

APPROVED

DAVID D. DE JESUS, PRESIDENT

DATE:

MATTHEW KUNS, FIELD OPERATIONS

DATE:

**MALCOLM  
PIRNIÉ**



REVISIONS			
NO.	BY	DATE	REMARKS

DES TD  
DWN AR  
CKD MS

COVINA IRRIGATING COMPANY  
GLENDDORA, CALIFORNIA  
UV/CHLORAMINES FOR TEMPLE WTP

TEMPLE WATER TREATMENT PLANT  
TITLE SHEET

COPYRIGHT © 2009  
MALCOLM PIRNIÉ, INC.  
DATE DECEMBER 2009  
G SHEET 1 OF 2  
CAD REF. NO. 5324A002

# ABBREVIATIONS

ACH	ALUMINUM CHLOROHYDRATE SOLUTION	JT	JOINT
AMM	AQUEOUS AMMONIA	L	ANGLE (STRUCTURAL SHAPE)
APPROX	APPROXIMATELY	LF	LINEAR FEET
BC	BOTTOM OF CURB	LG	LONG
BF	BLIND FLANGE	LIT	LEVEL INDICATING TRANSMITTER
BFV	BUTTERFLY VALVE	LLWS	LOW LOW WATER SURFACE
BLDG	BUILDING	LP	LOW POINT
BM	BENCH MARK	LR	LONG RADIUS
BOT	BOTTOM	LWS	LOW WATER SURFACE
BV	BALL VALVE	MAX	MAXIMUM
C	COMBINED	MFGR	MANUFACTURER
CAP	CAPACITY	MH	MANHOLE
CB	CATCH BASIN	MIN	MINIMUM
CC	CENTER TO CENTER	MJ	MECHANICAL JOINT
CL	CENTERLINE	#, NO	NUMBER
CEN	CENTER	NTS	NOT TO SCALE
CHEM	CHEMICAL	OC	ON CENTER
CL	CHAIN LINK	OD	OUTER DIAMETER
CLR	CLEAR	PE	PLAIN END
CLS	CHLORINE SOLUTION	PB	PULL BOX
CML	CEMENT MORTAR LINED	PL	PLATE
CMLC	CEMENT MORTAR LINED AND COATED	PV	PLUG VALVE
CW	CITY WATER	PVC	POLY VINYL CHLORIDE
CONC	CONCRETE	R	RADIUS
CONN	CONNECTION	RED	REDUCER
CONT	CONTINUATION	REINF	REINFORCED
CPLG	COUPLING	REQ'D	REQUIRED
CJ	CONSTRUCTION JOINT	REST	RESTRAINED
CIC	COVINA IRRIGATING COMPANY	SAN	SANITARY
CTRL	CONTROL	SCH	SCHEDULE
CU	COPPER	SCE	SOUTHERN CALIFORNIA EDISON
CV	CHECK VALVE	SHT	SHEET
CY	CUBIC YARD	SLP	SLOPE
D	DRAIN	SMH	SEWER MANHOLE
DET	DETAIL	SR	SHORT RADIUS
DI	DUCTILE IRON	SSPWC	STANDARD SPECIFICATIONS FOR PUBLIC WORKS CONSTRUCTION
DIA, Ø	DIAMETER	STA	STATION
DIM	DIMENSION	ST STL	STAINLESS STEEL
DWG	DRAWING	STL	STEEL
DWLS	DOWELS	STD	STANDARD
EF	EACH FACE	SD	STORM DRAIN
EW	EACH WAY	SPEC	SPECIFICATION
ELEC	ELECTRICAL	SQ	SQUARE
EHH	ELECTRICAL HAND HOLE	SQYD	SQUARE YARD
EJ	EXPANSION JOINT	ST	STREET
EL	ELEVATION	SWK	SIDEWALK
EMH	ELECTRICAL MANHOLE	T	TELEPHONE
ENGR	ENGINEER	T/C	TOP OF CONCRETE
EXIST	EXISTING	TC	TOP OF CURB
EXP	EXPANSION	THK	THICKNESS
FA	FIRE ALARM	TW	TOP OF WALK
FIN	FINISH	TYP	TYPICAL
FL	FLOOR	UG	UNDERGROUND
FLG	FLANGE	UV	ULTRAVIOLET
FM	FORCE MAIN	UVT	ULTRAVIOLET TRANSMITTANCE
FND	FOUNDATION	UON	UNLESS OTHERWISE NOTED
FRP	FIBER REINFORCED PLASTIC	V	VALVE
FT	FOOT	VERT	VERTICAL
G	GAS	W	WATER
GAL	GALLON	WT	WEIGHT
GALV	GALVANIZED	WV	WATER VALVE
GR	GRADE	WWF	WELDED WIRE FABRIC
GV	GATE VALVE	WWM	WELDED WIRE MESH
HDPE	HIGH DENSITY POLY ETHYLENE	W/	WITH
HM	HIGH MARSH	WS	WATER SURFACE
HP	HIGH POINT		
HPR	HIGH PRESSURE	E	EAST
HWS	HIGH WATER SURFACE	W	WEST
HYPO	HYPOCHLORITE SOLUTION	N	NORTH
ID	INSIDE DIAMETER	S	SOUTH
IE	INVERT ELEVATION	NE	NORTHEAST
IN	INLET	NW	NORTHWEST
INFL	INFLUENT	SE	SOUTHEAST
INV	INVERT	SW	SOUTHWEST

# LEGEND

SEE ELECTRICAL LEGENDS FOR SYMBOLS AND CONDUIT DESIGNATIONS.

EXISTING	NEW
_____	_____
_____	_____
_____	_____
_____	_____
_____	_____

EXISTING ABOVEGROUND WORK  
 EXISTING UNDERGROUND WORK  
 WORK UNDER THIS CONTRACT  
 UNDERGROUND WORK THIS CONTRACT

# LEGEND (CONT.)

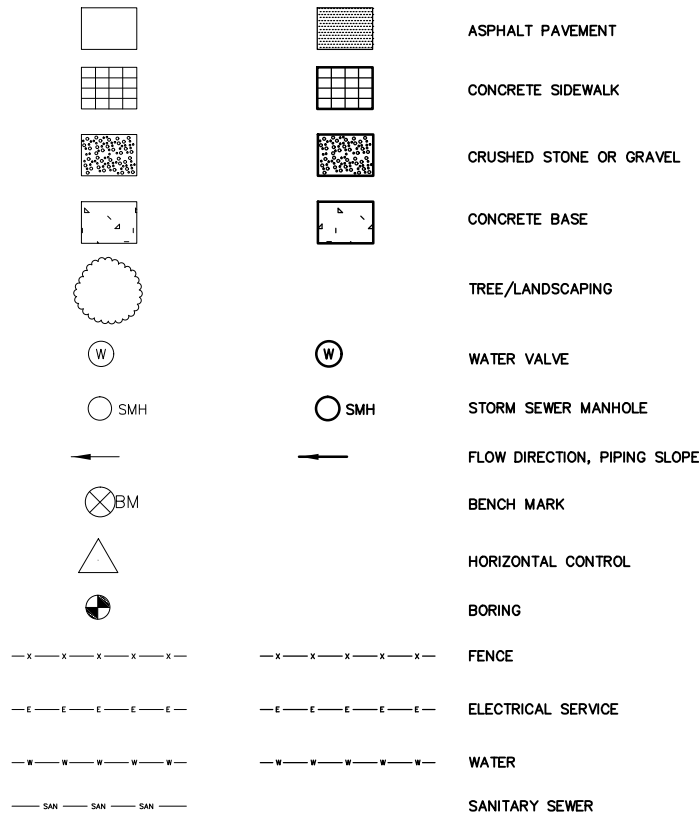

# PIPING

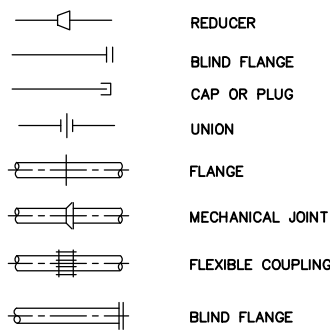

# VALVES

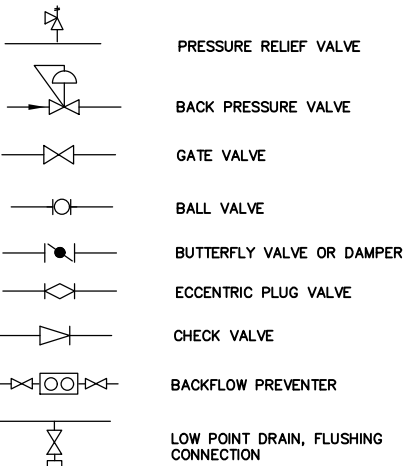

# VALVES (CONT.)

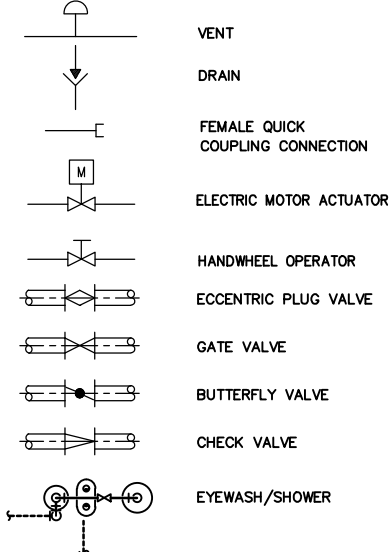

# PUMPS

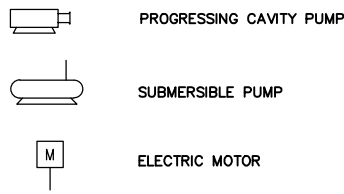

# INDEX OF DRAWINGS

DWG NO.	DISCIPLINE	DRAWING TITLE
G-1	GENERAL	TITLE SHEET
G-2	GENERAL	DRAWING INDEX, SYMBOLS, ABBREVIATIONS & GENERAL NOTES
GC-1	CIVIL	CIVIL DETAILS 1
GC-2	CIVIL	CIVIL DETAILS 2
C-1	CIVIL	EXISTING SITE AND DEMOLITION PLAN
C-2	CIVIL	SURFACE IMPROVEMENTS PLAN
C-3	CIVIL	PIPING PLAN
C-4	CIVIL	ENLARGED PIPING PLAN
C-5	CIVIL	UV FACILITY SECTIONS AND PIPE PROFILES
C-6	CIVIL	PIPING DETAILS
A-1	ARCH	SYMBOLS, ABBREVIATIONS AND GENERAL NOTES
A-2	ARCH	UV FACILITY - ELECTRICAL ROOM BUILDING PLANS
A-3	ARCH	UV FACILITY-ELECTRICAL ROOM ELEVATIONS AND WALL SECTIONS
A-4	ARCH	CHEMICAL FACILITY PLANS AND CANOPY ELEVATIONS
A-5	ARCH	DOOR SCHEDULE AND DETAILS
GS-1	STRUCT	GENERAL NOTES AND ABBREVIATIONS
GS-2	STRUCT	STRUCTURAL DETAILS 1
GS-3	STRUCT	STRUCTURAL DETAILS 2
S-1	STRUCT	UV FACILITY PLAN AT EL 658.00 UON
S-2	STRUCT	UV FACILITY PLAN AT EL 665.00 UON
S-3	STRUCT	UV FACILITY, PLAN AT EL 675.50 UON & BEAM SCHEDULE
S-4	STRUCT	UV FACILITY ROOF PLAN
S-5	STRUCT	UV FACILITY SECTIONS 1
S-6	STRUCT	UV FACILITY SECTIONS 2 AND DETAILS
S-7	STRUCT	CHEMICAL FACILITY PLAN
S-8	STRUCT	CHEMICAL FACILITY SECTIONS AND DETAILS
S-9	STRUCT	BACKWASH CLARIFIER PARTIAL PLANS AND DETAILS
GM-1	MECHANICAL	MECHANICAL DETAILS 1
GM-2	MECHANICAL	MECHANICAL DETAILS 2
M-1	MECHANICAL	UV FACILITY LOWER LEVEL PLAN
M-2	MECHANICAL	UV FACILITY UPPER LEVEL PLAN
M-3	MECHANICAL	UV FACILITY SECTIONS AND DETAILS
M-4	MECHANICAL	CHEMICAL FACILITY PLAN
M-5	MECHANICAL	CHEMICAL FACILITY SECTIONS AND MISCELLANEOUS DETAILS
M-6	MECHANICAL	CHEMICAL FEED PUMP PARTIAL PLANS AND SECTIONS
M-7	MECHANICAL	METERING PUMP ENCLOSURE/INFLUENT VAULT PLANS AND SECTION
H-1	HVAC	SYMBOLS, ABBREVIATIONS, AND GENERAL NOTES
H-2	HVAC	DETAILS, CONTROL SCHEMATICS, & EQUIPMENT SCHEDULE
H-3	HVAC	UV FACILITY UPPER AND LOWER LEVEL PLAN
GE-1	ELECTRICAL	ELECTRICAL LEGEND AND ABBREVIATIONS
GE-2	ELECTRICAL	ELECTRICAL STANDARD DETAILS
E-1	ELECTRICAL	SITE CONDUIT PLAN
E-2	ELECTRICAL	ONE LINE DIAGRAM
E-3	ELECTRICAL	MCC-UV ELEVATION/LOAD SUMMARY AND PANELBOARD SCHEDULE
E-4	ELECTRICAL	UV FACILITY UPPER LEVEL POWER PLAN
E-5	ELECTRICAL	UV FACILITY LOWER LEVEL POWER PLAN
E-6	ELECTRICAL	CHEMICAL STORAGE FACILITY POWER PLAN
E-7	ELECTRICAL	SODIUM HYPOCHLORITE/FILTRATION BUILDING POWER PLAN
E-8	ELECTRICAL	BLOCK DIAGRAM 1
E-9	ELECTRICAL	BLOCK DIAGRAM 2
E-10	ELECTRICAL	CONTROL SCHEMATICS 1
E-11	ELECTRICAL	CONTROL SCHEMATICS 2
E-12	ELECTRICAL	CABLE AND CONDUIT SCHEDULE 1
E-13	ELECTRICAL	CABLE AND CONDUIT SCHEDULE 2
E-14	ELECTRICAL	CABLE AND CONDUIT SCHEDULE 3
GI-1	I & C	INSTRUMENTATION AND CONTROL SYMBOLS AND LEGENDS
GI-2	I & C	INSTRUMENTATION INSTALLATION DETAILS 1/2
GI-3	I & C	INSTRUMENTATION INSTALLATION DETAILS 2/2
I-1	I & C	CONTROL SYSTEM ARCHITECTURE
I-2	I & C	PLANT INFLUENT P&ID
I-3	I & C	SERVICE PUMPS P&ID
I-4	I & C	UV FACILITIES P&ID
I-5	I & C	SODIUM HYPOCHLORITE STORAGE AND FEED P&ID
I-6	I & C	AQUEOUS AMMONIA STORAGE AND FEED P&ID
I-7	I & C	ACH STORAGE AND FEED P&ID
I-8	I & C	MISCELLANEOUS P&ID
I-9	I & C	MCP PANEL LAYOUT AND POWER DISTRIBUTION

# GENERAL NOTES

- ALL DIMENSIONS ARE TO EDGE OF STRUCTURES, FACE OF CURBS OR EDGE OF PAVEMENTS UNLESS SPECIFICALLY INDICATED OTHERWISE.
- EXISTING UTILITY LOCATIONS, SIZES AND ELEVATIONS SHOWN ON THE DRAWINGS ARE APPROXIMATE AND ARE INTENDED ONLY TO INDICATE THE EXISTENCE OF SUCH UTILITIES IN THE AREAS SHOWN. BEFORE PROCEEDING WITH THE WORK, THE CONTRACTOR SHALL VERIFY UTILITY LOCATIONS AND NOTIFY THE ENGINEER OF ANY DISCREPANCIES.
- ALL UTILITIES SHALL BE PROTECTED FROM ANY DAMAGE AS A RESULT OF THE WORK INCLUDED IN THIS CONTRACT. IT SHALL BE THE RESPONSIBILITY OF THE CONTRACTOR TO REPAIR AND/OR REPLACE ANY DAMAGED UTILITIES TO THE SATISFACTION OF THE UTILITY OWNER. VERIFICATION OF EXISTING UTILITIES SHALL INCLUDE CALLING "DIGALERT" HOTLINE FOR MARK-OUT BY UTILITY COMPANIES.
- EXISTING RIM ELEVATIONS FOR MANHOLES, VALVE BOXES AND CATCH BASINS SHALL BE ADJUSTED TO MEET FINISH GRADE.
- ALL AREAS DISTURBED BY THE CONTRACTOR SHALL BE RESTORED TO THEIR ORIGINAL CONDITION OR AS INDICATED ON THE CONTRACT DRAWINGS.
- CONSTRUCTION VEHICLES AND EQUIPMENT WITH LOADS GREATER THAN H-20 HIGHWAY LOADS SHALL NOT CROSS EXISTING UNDERGROUND STRUCTURES WITHOUT BRIDGING. FURTHERMORE, VEHICLES USED TO HAUL DEMOLISHED MATERIALS, UNSUITABLE MATERIAL, EARTH, CONCRETE, ETC., SHALL AVOID CROSSING OVER EXISTING UNDERGROUND STRUCTURES WHENEVER POSSIBLE. WHEN CROSSING CANNOT BE AVOIDED, SUITABLE BRIDGING SHALL BE PROVIDED.
- NEW ROADWAY, PAVEMENT, CURB AND SIDEWALKS TOP ELEVATION SHALL BE FINISHED TO MATCH ADJOINING ROADWAY, PAVEMENT, CURB AND SIDEWALK ELEVATIONS UNLESS OTHERWISE NOTED.
- CONTRACTOR TO INSTALL SHEETING, SHORING AND BRACING AS NECESSARY TO FACILITATE REMOVAL OF SUBGRADE AS DISCUSSED IN THE GEOTECHNICAL REPORT AND SPECIFIED IN SECTION 02315.
- CONTRACTOR SHALL PREPARE AND SUBMIT TRAFFIC CONTROL PLANS AND OBTAIN ROADWAY CLOSURE PERMIT FROM COUNTY OF LOS ANGELES FOR ALL WORK IN THE ROADWAY, AT NO ADDITIONAL COST TO OWNER.



REVISIONS			
NO.	BY	DATE	REMARKS

DES TD  
 DWN AR  
 CRD MS

COVINA IRRIGATING COMPANY  
 GLENDORA, CALIFORNIA  
**UV/CHLORAMINES FOR TEMPLE WTP**

TEMPLE WATER TREATMENT PLANT  
**DRAWING INDEX, SYMBOLS  
 ABBREVIATIONS AND GENERAL NOTES**

SCALE: NTS

COPYRIGHT © 2009  
 MALCOLM PIRNIE, INC.  
 DATE DECEMBER 2009  
 G SHEET 2 OF 2  
 CAD REF. NO. 5324A002

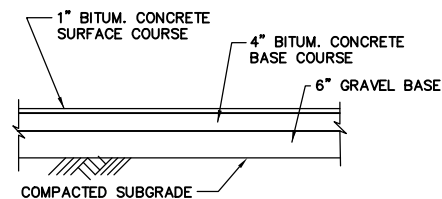

**TYPICAL ASPHALT PAVEMENT** 1  
- GC1

NOTE: PAVEMENT IN PUBLIC RIGHT-OF-WAY SHALL BE IN ACCORDING WITH STANDARD SPECIFICATIONS FOR PUBLIC WORKS CONSTRUCTION ("GREENBOOK"), 2006 EDITION, AND LOS ANGELES COUNTY ADDITIONS AND AMENDMENTS TO SSPWC ("GRAYBOOK"), 2006 EDITION.

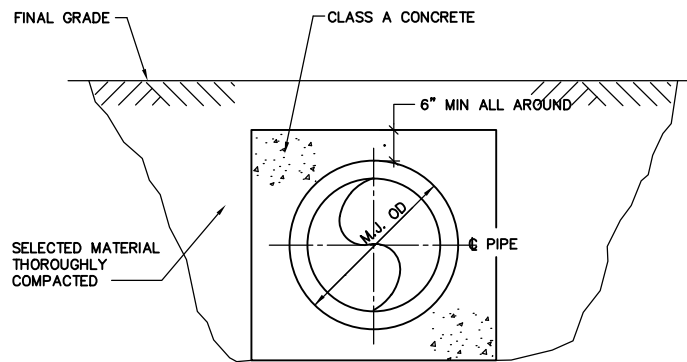

**CONCRETE ENCASEMENT DETAIL** 7  
- GC1  
NOT TO SCALE

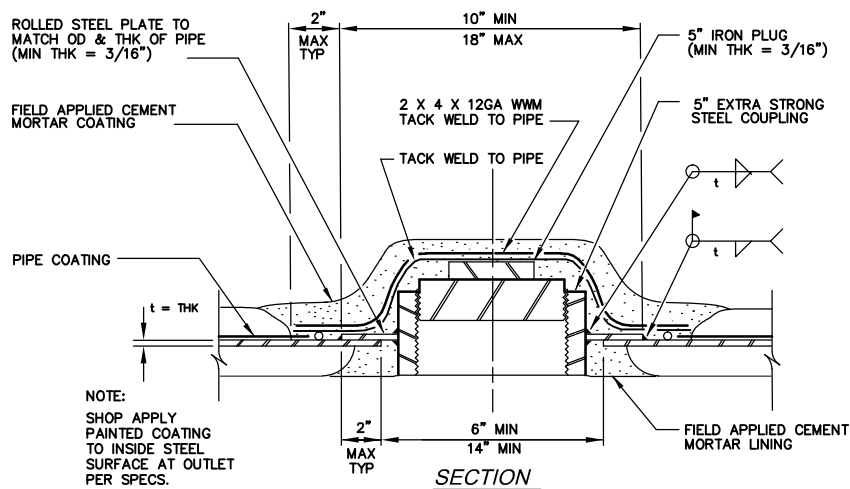

**HANDHOLE** 5  
- GC1  
NOT TO SCALE

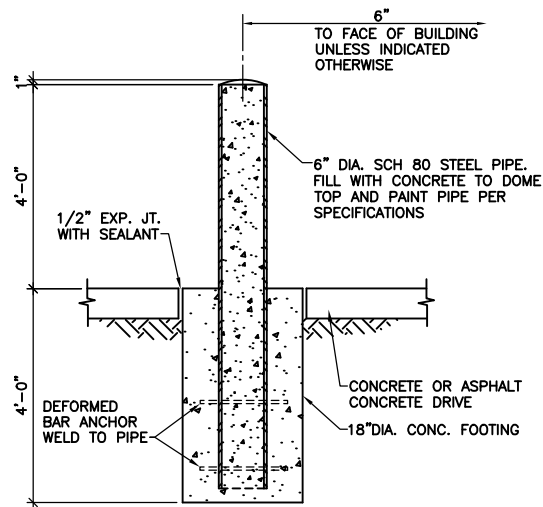

**SITE BOLLARD** 2  
- GC1  
NTS

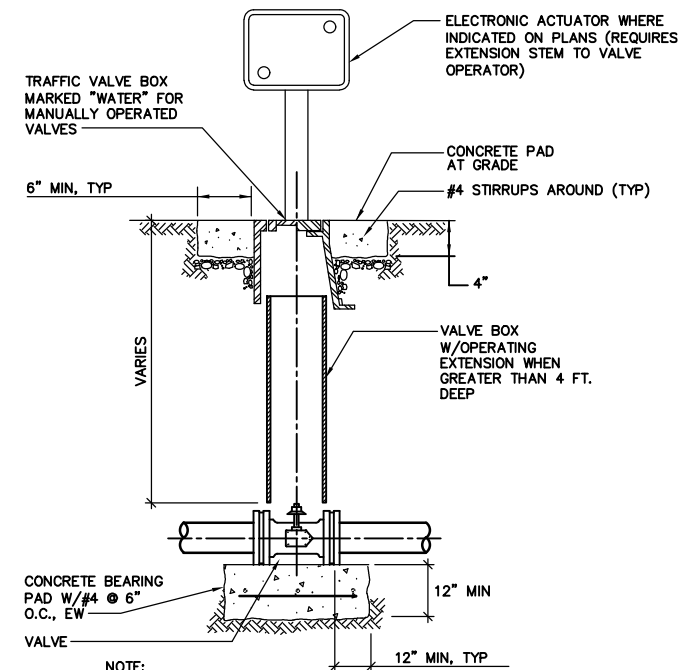

**BURIED VALVE/BOX** 3  
- GC1  
NTS

NOTE:  
1. AT BURIED VALVES 3" AND SMALLER, PROVIDE A CONCRETE UTILITY BOX FOR VALVE ACCESS.

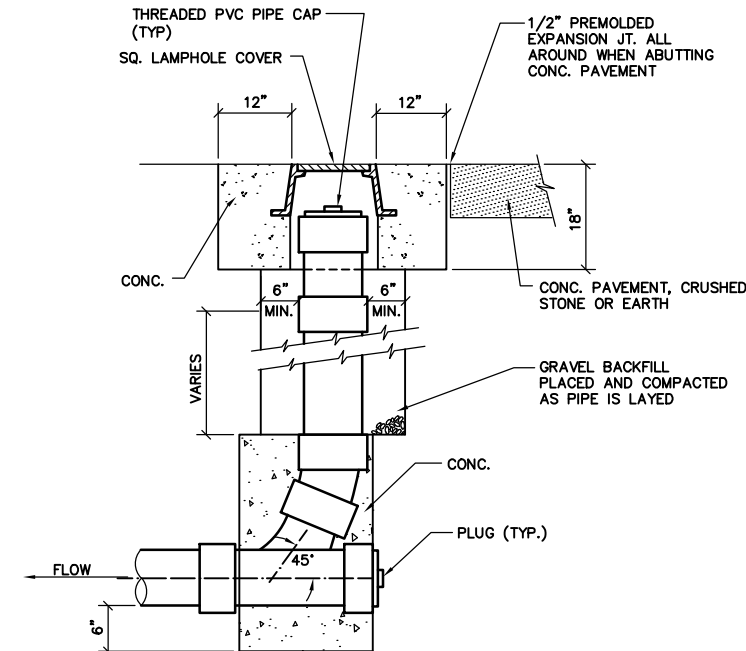

**TYPICAL DRAIN CLEANOUT** 4  
- GC1  
NTS

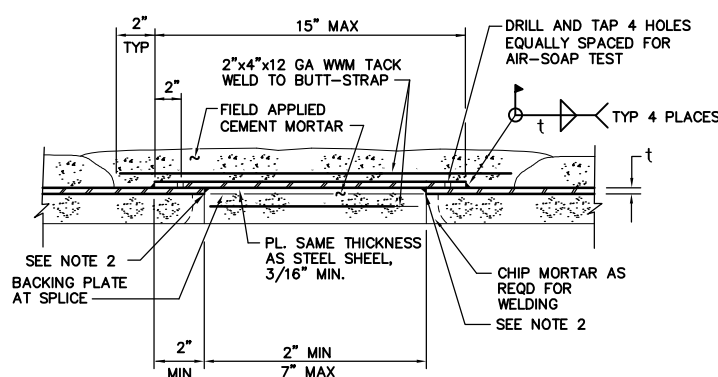

**BUTT-STRAP JOINT** 6  
- GC1  
NOT TO SCALE

NOTES:  
1. PROVIDE HANDHOLE FOR APPLICATION OF CEMENT MORTAR LINING ON PIPES 24" DIA OR LESS OR WHERE ACCESS TO THE PIPE INTERIOR IS NOT FEASIBLE. SEE HANDHOLE DETAIL THIS SHEET.  
2. INTERIOR WELD NOT REQUIRED ON PIPE 24" DIA AND SMALLER.

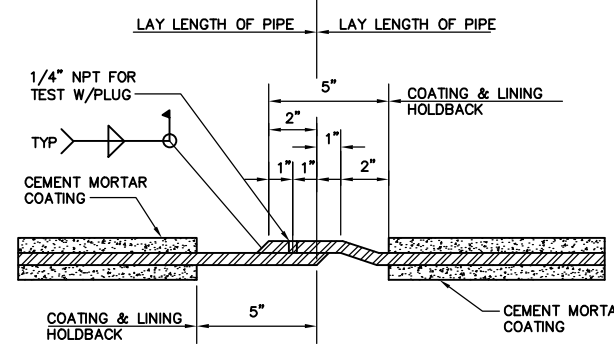

**CMLC STEEL PIPE JOINT** 8  
- GC1  
NOT TO SCALE

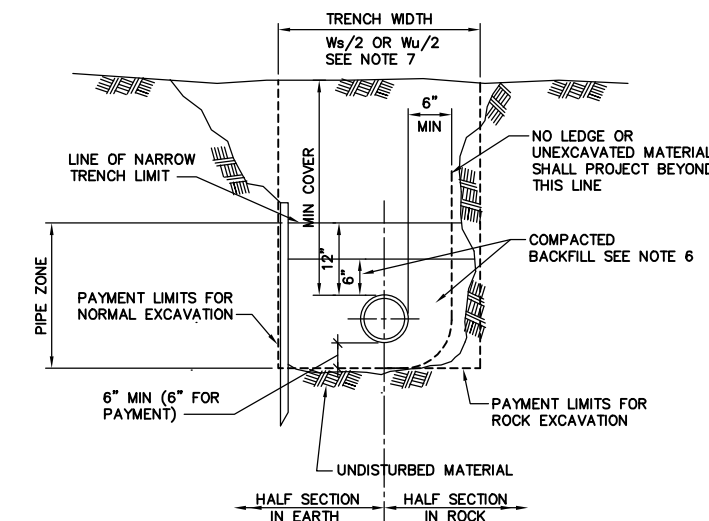

NOTES:  
1. TRENCHES MAY BE EXCAVATED WIDER THAN TRENCH WIDTH  $W_s$  ABOVE THE "LINE OF NARROW TRENCH LIMIT".  
2. BELOW THE "LINE OF NARROW TRENCH LIMIT" THE TRENCH SHALL NOT BE EXCAVATED BEYOND THE TRENCH WIDTH  $W_s$ .  
3. SHEETING IF USED IN ALL CASES SHALL BE LEFT IN PLACE BELOW A LINE 12" ABOVE THE TOP OF THE PIPE. UNLESS OTHERWISE INDICATED OR DIRECTED.  
4. "COVER" AT ANY POINT SHALL BE DEFINED AS THE VERTICAL DISTANCE FROM THE UPPER MOST POINT OF THE PIPE TO A LINE WHICH CONNECTS THE SURFACE OF UNDISTURBED GROUND AT EITHER SIDE OF THE TRENCH AND IS AT RIGHT ANGLES TO THE DIRECTION OF THE PIPE.  
5. WHERE THE FUTURE EXTENSION OF A PLUGGED PIPE OR A PLUGGED BRANCH WILL ENTAIL ROCK EXCAVATION THE TRENCH EXCAVATION IN ROCK SHALL BE EXTENDED FOR A DISTANCE OF 6'-0" BEYOND THE PLUG.  
6. SELECTED EXCAVATED MATERIAL WITH NO STONES LARGER THAN 2" FOR CAST IRON, DUCTILE IRON AND CONCRETE PIPES. SAND TO BE USED FOR PLASTIC, STEEL AND CEMENT-ASBESTOS PIPES.  
7. FOR SHEETED TRENCH  $W_s = 4/3 D + 32"$  OR 50" WHICHEVER IS GREATER. FOR UNSHEETED TRENCH  $W_u = 4/3 D + 18"$  OR 36" WHICHEVER IS GREATER.

**TRENCH SECTION FOR PIPE INSTALLATION** 9  
- GC1  
NTS

User: MARTINEZ, Spec: PIRNIE STANDARD File: I:\ACAD\PROJ\5324002.dwg Date: 06/27/2009 Time: 14:08 Layout: GC1



NO.	BY	DATE	REVISIONS	REMARKS

DES TD  
DWN AR  
CRD MS

COVINA IRRIGATING COMPANY  
GLENORA, CALIFORNIA  
**UV/CHLORAMINES FOR TEMPLE WTP**

TEMPLE WATER TREATMENT PLANT  
**CIVIL DETAILS 1**

SCALE

COPYRIGHT © 2009  
MALCOLM PIRNIE, INC.  
DATE DECEMBER 2009  
GC SHEET 1 of 2  
CAD REF. NO. 5324A031





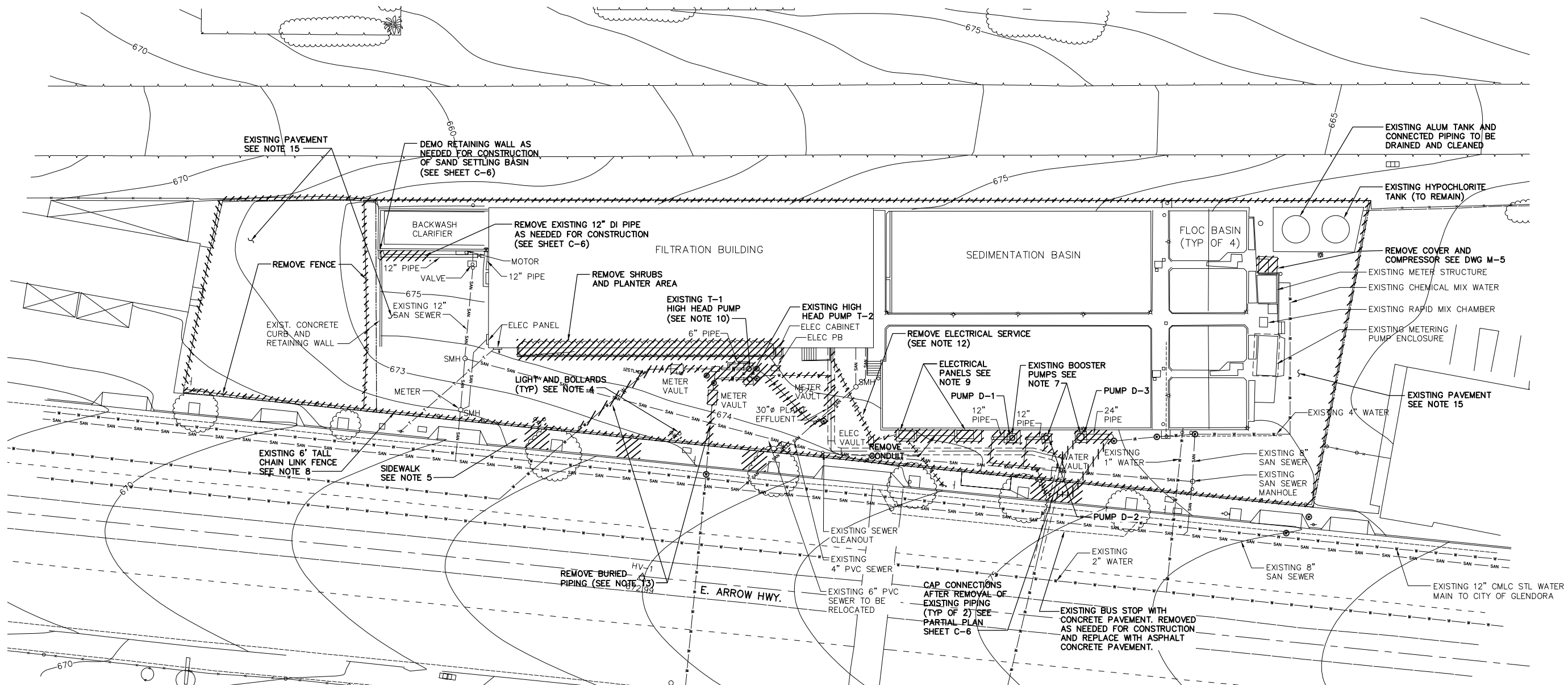

**NOTES:**

1. ALL EXISTING WATER PUMPS AND ASSOCIATED ELECTRICAL PANELS, CONDUIT AND PULL BOXES SHALL BE REMOVED AND PROPERLY DISPOSED OF.
2. UNLESS OTHERWISE SHOWN, PIPING SHALL BE REMOVED TO THE EXTENT NEEDED TO MAKE NEW CONNECTIONS SHOWN ON OTHER DRAWINGS. LIMITS OF PIPING DEMOLITION SHOWN ON THIS DRAWING ARE APPROXIMATE.
3. COORDINATE DEMOLITION ACTIVITIES WITH CIC OPERATIONS AND NEW WORK TO MINIMIZE PLANT DOWNTIME. EXISTING BOOSTER PUMPS SHALL REMAIN IN SERVICE DURING CONSTRUCTION OF NEW UV FACILITY EXCEPT AS ACCEPTED BY ENGINEER.
4. REMOVE SITE LIGHTING AND BOLLARDS. DUCT BANK AND CONDUITS SHALL BE REMOVED AS NEEDED FOR CONSTRUCTION.
5. REMOVE AND REPLACE SIDEWALK AS NEEDED FOR CONSTRUCTION. ALL PORTIONS OF SIDEWALK REMOVED SHALL BE REPLACED WITH NEW, PER CITY OF GLENDORA STANDARD DESIGN AND SPECIFICATION NO. 1.02.
6. EXISTING TREES SHALL BE PROTECTED IN PLACE.
7. REMOVE EXISTING BOOSTER PUMPS AND CANS. PUMP CANS ARE APPROXIMATELY 20-INCH DIAMETER TO 5- FEET BELOW GRADE, 20-INCH DIAMETER TO 7- FEET BELOW GRADE, AND 36-INCH DIAMETER TO 11- FEET BELOW GRADE FOR PUMPS D1, D2, AND D3, RESPECTIVELY. PUMP CAN FOR PUMP D-1 TO REMAIN UNTIL AFTER TEMPORARY BYPASS PUMPING IS COMPLETE (SEE NOTE 10).
8. ALL FENCE SHALL BE REMOVED AND REPLACED WITH NEW PER SHEET C-2. CONTRACTOR SHALL INSTALL TEMPORARY FENCING AS NEEDED TO MAINTAIN SITE SECURITY DURING CONSTRUCTION. FENCE POSTS AND CONCRETE BASES SHALL BE REMOVED COMPLETELY PRIOR TO BACK FILLING.
9. EXISTING ELECTRICAL PANELS AND EXPOSED CONDUITS ON SEDIMENTATION BASIN SOUTH WALL SHALL BE REMOVED AND REPLACED WITH BURIED JUNCTION BOX AND BURIED CONDUIT. SEE SHEET E-1.
10. EXISTING PUMPS T-1 AND T-2 SHALL BE REMOVED IN THEIR ENTIRETY. BOTH PUMP CANS ARE APPROXIMATELY 16 INCH DIAMETER TO 6- FEET BELOW GRADE. EXISTING PUMP T-1 WITH EXISTING CV, AIR RELEASE VALVE, ISOLATION VALVES AND COUPLINGS ON DISCHARGE PIPE SHALL BE RELOCATED TO EXISTING PUMP CAN FOR PUMP D-1 TO PROVIDE TEMPORARY BYPASS PUMPING BACK TO THE EXISTING 12" SUBURBAN FORCE MAIN. SEE SHEET C-3 FOR TEMPORARY BYPASS PIPING. RELOCATION OF T-1 PUMP AND INSTALLATION OF BYPASS PIPING SHALL OCCUR AT BEGINNING OF CONSTRUCTION. SEE SPECIFICATION SECTION 0114.3.
11. WHERE ITEMS TO BE DEMOLISHED ARE BELOW GRADE EITHER COMPLETELY OR IN PART, THE EXCAVATED AREA SHALL BE BACKFILLED TO FINISHED GRADE AS SHOWN ON DRAWING C-2.
12. ELECTRICAL CABLE SHALL BE REMOVED TO POWER POLE. CONDUIT SHALL BE ABANDONED OR REMOVED AS NEEDED FOR CONSTRUCTION. HANDHOLES AND MANHOLES SHALL BE REMOVED AS SHOWN. COORDINATE ELECTRICAL DISCONNECTION WITH OWNER AND SCE.
13. CONTRACTOR SHALL PROVIDE LINE STOP SERVICE ON ALL PIPES LEAVING THE OWNER'S PROPERTY PRIOR TO CUTTING THE PIPE (TOTAL OF THREE LOCATIONS) FOR ISOLATION OF FLOW. THERE ARE NO ACCESSIBLE ISOLATION VALVES FOR THESE LINES. LOCATIONS OF LINE STOPS TO BE COORDINATED WITH OWNER AND ENGINEER.
14. ALL WORK IN STREET SHALL BE IN ACCORDANCE WITH STANDARD SPECIFICATIONS FOR PUBLIC WORKS CONSTRUCTION ("GREENBOOK"), 2006 EDITION, AND LOS ANGELES COUNTY ADDITIONS AND AMENDMENTS TO SSPWC ("GRAYBOOK"), 2006 EDITION.
15. ALL EXISTING PAVEMENT ON SITE SHALL BE REMOVED PRIOR TO INSTALLATION OF NEW PAVEMENT.

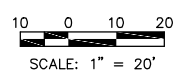
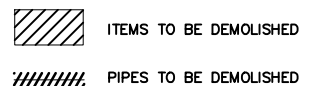

XREFS: \\VREF\PPSTGCP.dwg; \\VREF\VPSTGSP.dwg; \\VREF\5324-TBLK.dwg; IMAGES: None; User: Strachan; Spec: PIRNIE; STANDARD; File: \\VAD\PROU\5324\026.DWG; Covina\CVIL\5324\026.DWG; Scale: 1:1; Date: 08/18/2009; Time: 08:46; Layout: C1



NO.	BY	DATE	REVISIONS	REMARKS

DES TD  
 DWN AR  
 CKD MS

COVINA IRRIGATING COMPANY  
 GLENDORA, CALIFORNIA  
**UV/CHLORAMINES FOR TEMPLE WTP**

TEMPLE WATER TREATMENT PLANT  
**EXISTING SITE AND DEMOLITION PLAN**  
 SCALE: 1"=20"

COPYRIGHT © 2009  
 MALCOLM PIRNIE, INC.  
 DATE DECEMBER 2009  
 C SHEET 1 OF 6  
 CAD REF. NO. 5324A026

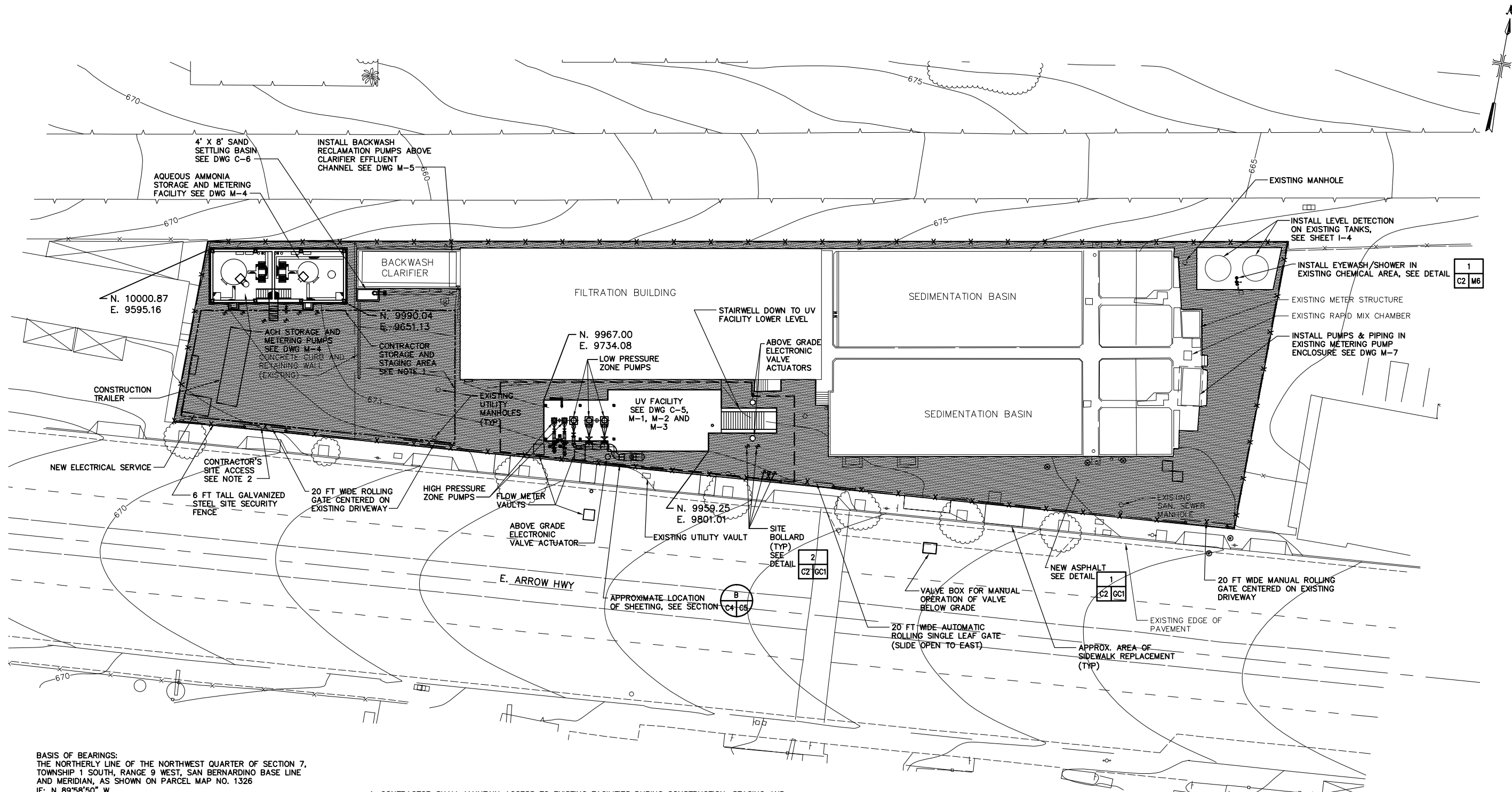

1  
C2 M6

2  
C2 GC1

B  
C4 C6

1  
C2 GC1

BASIS OF BEARINGS:  
THE NORTHERLY LINE OF THE NORTHWEST QUARTER OF SECTION 7,  
TOWNSHIP 1 SOUTH, RANGE 9 WEST, SAN BERNARDINO BASE LINE  
AND MERIDIAN, AS SHOWN ON PARCEL MAP NO. 1326  
IE: N 89°58'50" W

BENCH MARK:  
TOP OF CURB ANGLE POINT LOCATED AT THE SOUTHWEST  
CORNER OF OPERATIONS AND FILTER BUILDING AS SHOWN  
ON THE SITE PLAN AND VICINITY MAP PREPARED BY  
JAMES M. MONTGOMERY, CONSULTING ENGINEERS, INC.  
DATED 11-09-1965 ELEVATION = 674.75  
PLOTTED HEREON

- CONTRACTOR SHALL MAINTAIN ACCESS TO EXISTING FACILITIES DURING CONSTRUCTION. STAGING AND STORAGE OF MATERIAL LIMITED TO AREA SHOWN.
- CONTRACTOR SHALL MAINTAIN SECURE ACCESS AT THE LOCATION SHOWN. PRIMARY SITE ACCESS WILL BE AT THIS LOCATION EXCEPT AS REQUIRED FOR WORK ON EXISTING CHEMICAL FACILITIES.
- FENCE SHALL FOLLOW PROPERTY LINE AS CLOSELY AS POSSIBLE. FENCE POSTS SHALL BE INSTALLED ENTIRELY WITHIN CIC PROPERTY.
- PAVEMENT AREAS SHALL TERMINATE AT PROPERTY LINE OR AS SHOWN.
- CONTRACTOR SHALL OBTAIN OFF-SITE STORAGE/PARKING/LAYDOWN AREA AS NEEDED DURING CONSTRUCTION AT NO ADDITIONAL COST TO OWNER. NO ON-SITE OR OFF-SITE SPACE ADDITIONAL TO THAT SHOWN WILL BE PROVIDED BY OWNER.

6. ALL WORK IN STREET SHALL BE IN ACCORDANCE WITH STANDARD SPECIFICATIONS FOR PUBLIC WORKS CONSTRUCTION ("GREENBOOK"), 2006 EDITION, AND LOS ANGELES COUNTY ADDITIONS AND AMENDMENTS TO SSPWC ("GRAYBOOK"), 2006 EDITION.

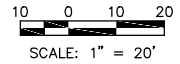

XREFS: \\XREF\SOP\UVFF1.dwg None IMAGES: None



REVISIONS			
NO.	BY	DATE	REMARKS

DES TD  
DWN JRM  
CKD MS

COVINA IRRIGATING COMPANY  
GLEN DORA, CALIFORNIA  
**UV/CHLORAMINES FOR TEMPLE WTP**

TEMPLE WATER TREATMENT PLANT  
**SURFACE IMPROVEMENTS PLAN**

SCALE: 1"=20'

COPYRIGHT © 2009  
MALCOLM PIRNIE, INC.  
DATE DECEMBER 2009  
C SHEET 2 OF 6  
CAD REF. NO. 5324A027

XREFS: None, IMAGES: None  
 User: dmjyryghyn Spec: PIRNIE STANDARD File: \\CAD\PROJ\5324A034.DWG Scale: 1:1 Date: 02/11/2010 Time: 16:39 Layout: C4

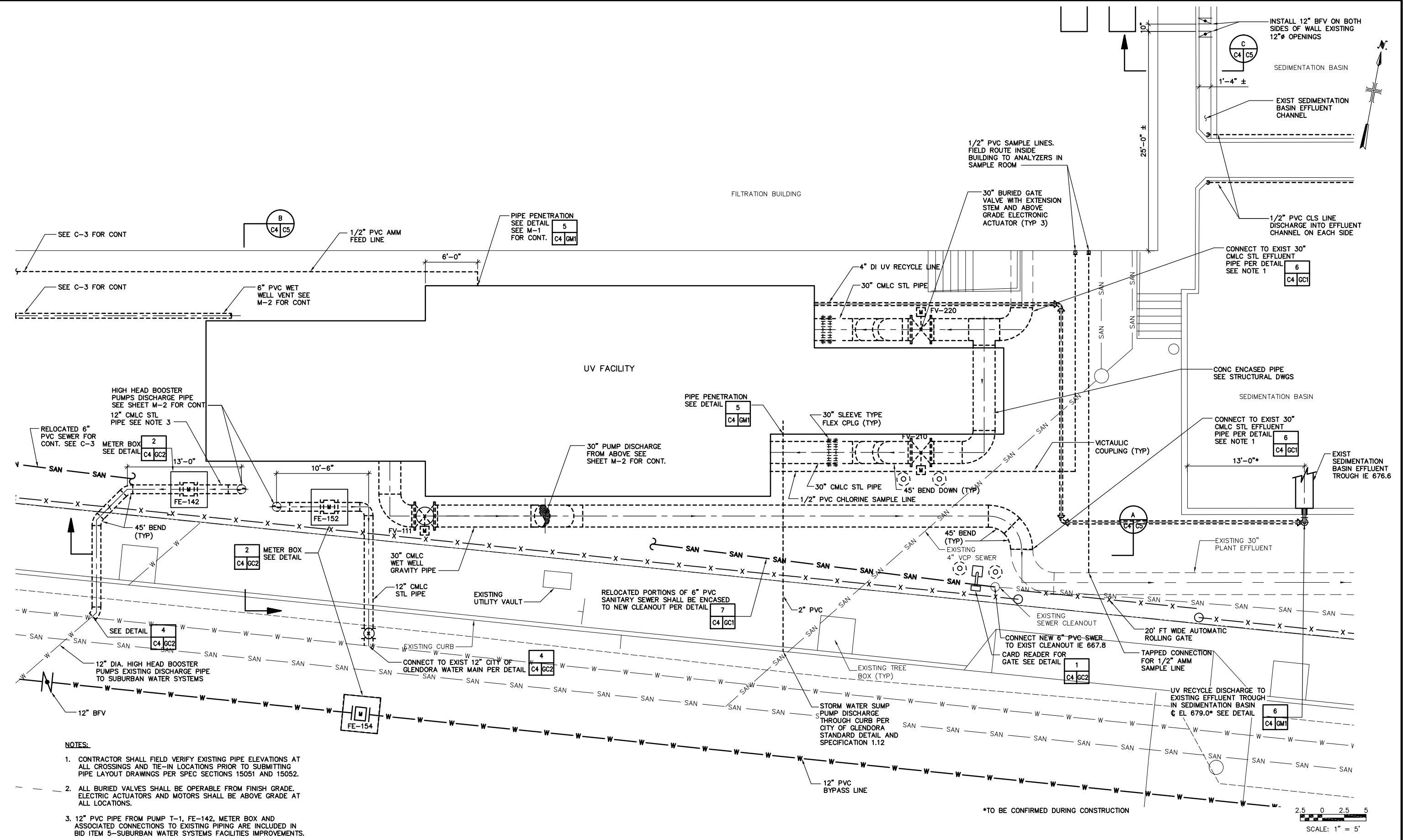

- NOTES:**
- CONTRACTOR SHALL FIELD VERIFY EXISTING PIPE ELEVATIONS AT ALL CROSSINGS AND TIE-IN LOCATIONS PRIOR TO SUBMITTING PIPE LAYOUT DRAWINGS PER SPEC SECTIONS 15051 AND 15052.
  - ALL BURIED VALVES SHALL BE OPERABLE FROM FINISH GRADE. ELECTRIC ACTUATORS AND MOTORS SHALL BE ABOVE GRADE AT ALL LOCATIONS.
  - 12" PVC PIPE FROM PUMP T-1, FE-142, METER BOX AND ASSOCIATED CONNECTIONS TO EXISTING PIPING ARE INCLUDED IN BID ITEM 5-SUBURBAN WATER SYSTEMS IMPROVEMENTS.

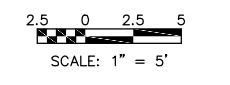

NO.	BY	DATE	REVISIONS	REMARKS

DES TD  
 DWN JRM  
 CKD MS

**COVINA IRRIGATING COMPANY**  
**GLENDORA, CALIFORNIA**  
**UV/CHLORAMINES FOR TEMPLE WTP**

**TEMPLE WATER TREATMENT PLANT**  
**ENLARGED PIPING PLAN**  
 SCALE: 1"=5'

COPYRIGHT © 2009  
 MALCOLM PIRNIE, INC.  
 DATE DECEMBER 2009  
 C SHEET 4 OF 6  
 CAD REF. NO. 5324A034

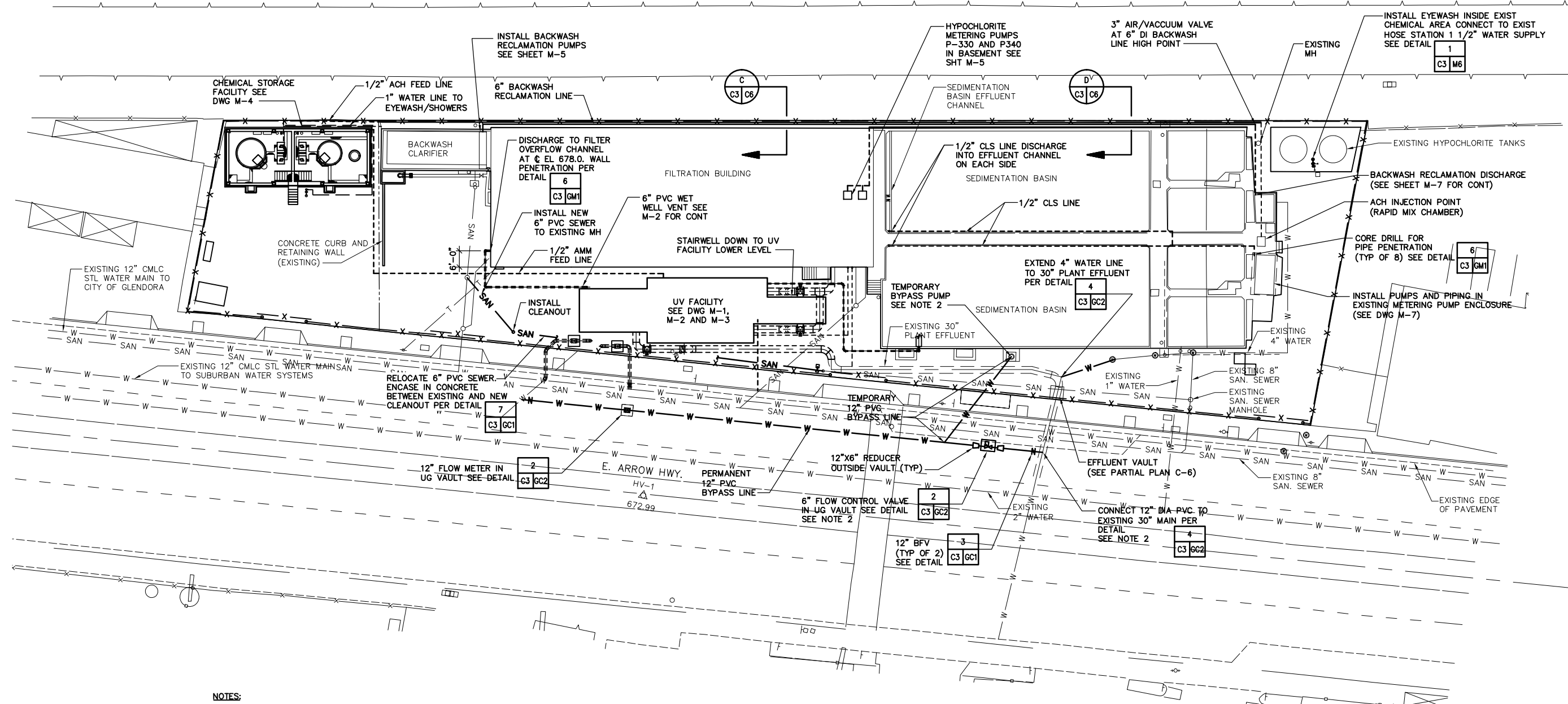

- NOTES:**
- ALL WORK IN STREET SHALL BE IN ACCORDANCE WITH STANDARD SPECIFICATIONS FOR PUBLIC WORKS CONSTRUCTION ("GREENBOOK"), 2006 EDITION, AND LOS ANGELES COUNTY ADDITIONS AND AMENDMENTS TO SSPWC ("GRAYBOOK"), 2006 EDITION.
  - TEMPORARY 12" PVC PIPE SHALL BE INSTALLED FOR BYPASS PUMPING DURING CONSTRUCTION OF UV FACILITY. PERMANENT 12" PVC BYPASS PIPE, VALVES AND FLOW METER SHALL REMAIN IN SERVICE AFTER CONSTRUCTION AS PERMANENT BYPASS CONNECTION. REMOVE PUMP T-1 AND D-1 PUMP CAN FOLLOWING TEMPORARY BYPASS PUMPING (SEE NOTE 7 ON SHEET C-1). THIS WORK IS INCLUDED IN BID ITEM 5-SUBURBAN WATER SYSTEMS FACILITIES IMPROVEMENTS.

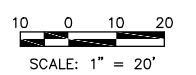

X:\REFS\REF\REF\REF.dwg None IMAGES:None User:dmyrghy File: \CAD\PROJ\5324A028.DWG Scale: 1:1 Date: 02/12/2010 Time: 09:59 Layout: C3



REVISIONS	
NO.	DATE

DES	TD
DWN	AR
CKD	MS

COVINA IRRIGATING COMPANY  
GLENORA, CALIFORNIA  
**UV/CHLORAMINES FOR TEMPLE WTP**

**TEMPLE WATER TREATMENT PLANT  
PIPING PLAN**  
SCALE: 1"=20'

DATE: DECEMBER 2009  
C SHEET 3 OF 6  
CAD REF. NO. 5324A028

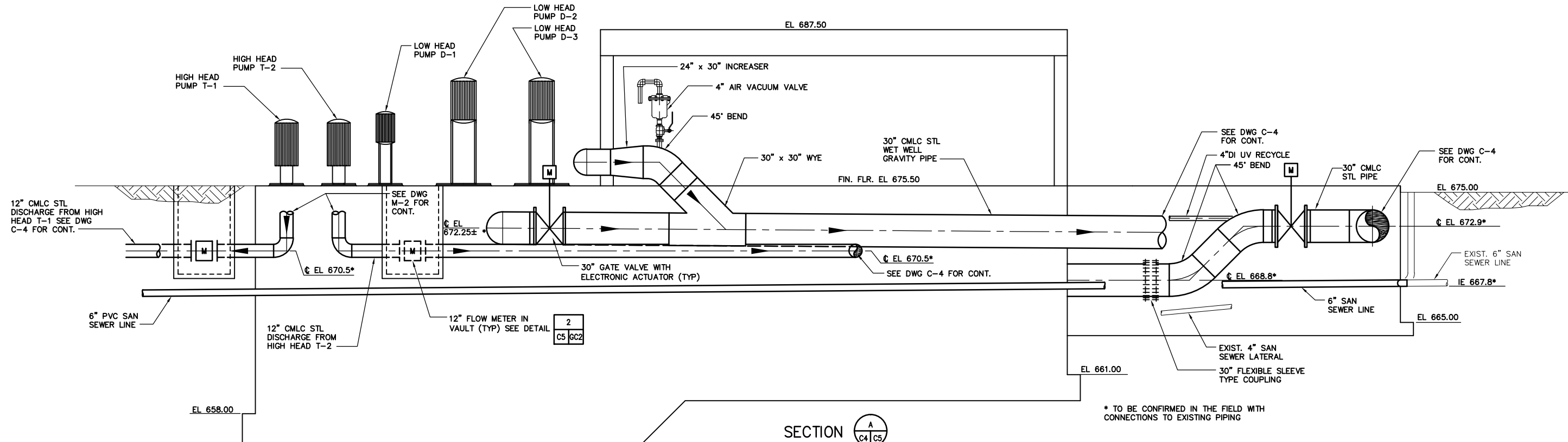

SECTION A  
C4 C5  
 SCALE: 1/4" = 1'-0"

\* TO BE CONFIRMED IN THE FIELD WITH CONNECTIONS TO EXISTING PIPING

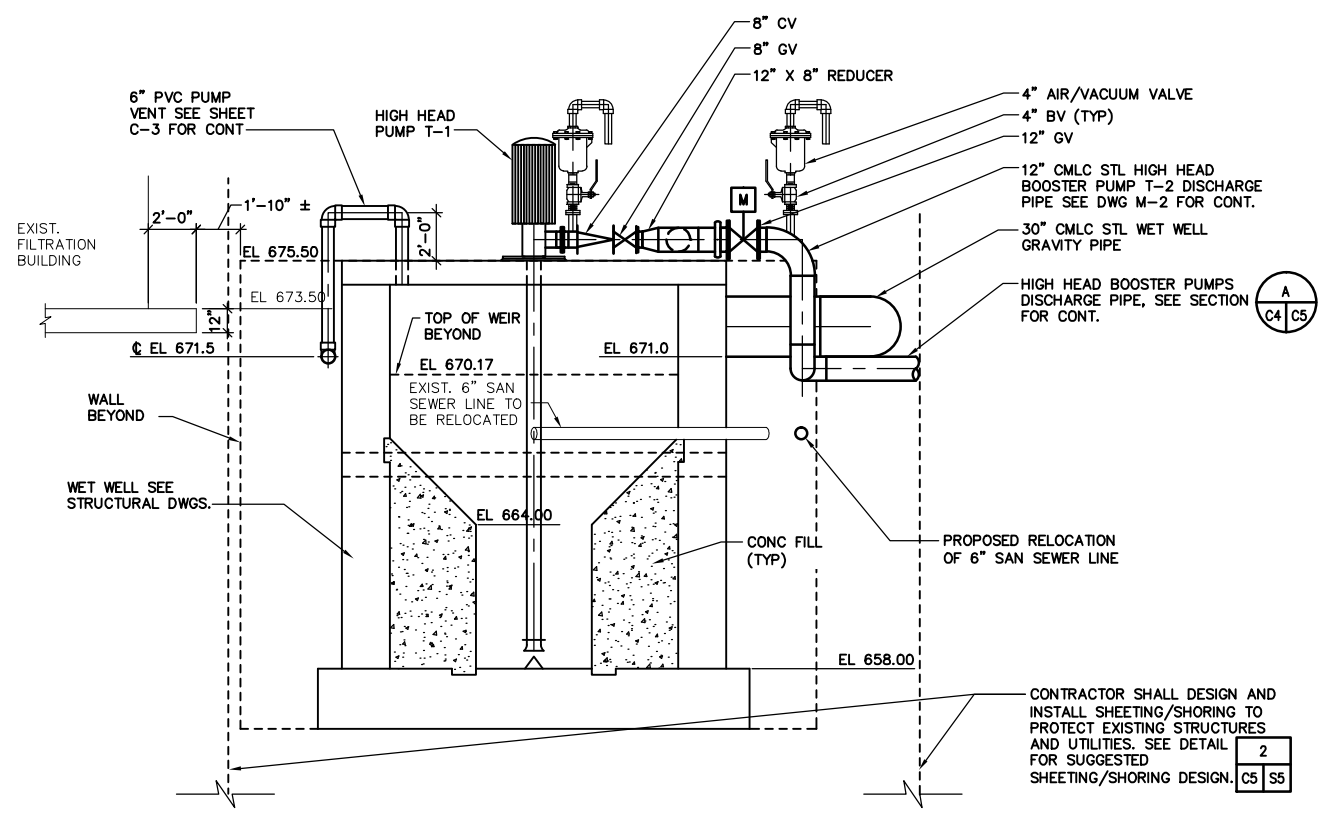

SECTION B  
C4 C5  
 SCALE: 1/4" = 1'-0"

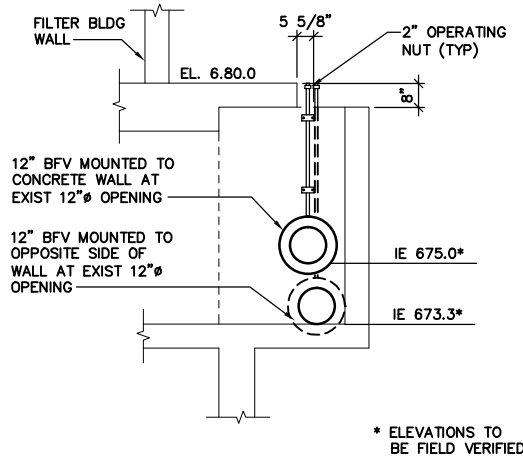

SECTION C  
C4 C5  
 SCALE: 1/4" = 1'-0"

\* ELEVATIONS TO BE FIELD VERIFIED

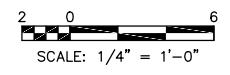

XREFS: None IMAGES: None  
 User: arivas Spec: PIRNIE STANDARD File: I:\ACAD\PROJ\5324002 Covina\CIVIL\3324A033.DWG Scale: 1:1 Date: 12/03/2009 Time: 14:55 Layout: C-5



REVISIONS		DES	TBD
NO.	BY	DATE	REMARKS

DES TBD  
 DWN JRM  
 CRD MS

COVINA IRRIGATING COMPANY  
 GLENDORA, CALIFORNIA  
**UV/CHLORAMINES FOR TEMPLE WTP**

TEMPLE WATER TREATMENT PLANT  
**UV FACILITY**  
**SECTIONS AND PIPE PROFILES**  
 SCALE: 1/4" = 1'-0"

COPYRIGHT © 2009  
 MALCOLM PIRNIE, INC.  
 DATE DECEMBER 2009  
 C SHEET 5 OF 6  
 CAD REF. NO. 5324A033



**ABBREVIATIONS**

AB -- ANCHOR BOLT	FDN. -- FOUNDATION	REINF. -- REINFORCING
ADD'L. -- ADDITIONAL	FE -- FIRE EXTINGUISHER	REQ'D. -- REQUIRED
ADJ. -- ADJUSTABLE	FIN. -- FINISH	REQ'MTS. -- REQUIREMENTS
AFF -- ABOVE FINISHED FLOOR	FL -- FINISH LINE	RM. -- ROOM
ALT. -- ALTERNATE	FLR. -- FLOOR	RO -- ROUGH OPENING
ALUM. -- ALUMINUM	FRP -- FIBERGLASS REINFORCED PLASTIC	S. -- SOUTH
& -- AND	FF -- FAR FACE	SCHED. -- SCHEDULE
ARCH. -- ARCHITECT OR ARCHITECTURAL	FTG. -- FOOTING	SECT. -- SECTION
ASTM -- AMERICAN SOCIETY FOR TESTING MATERIALS	FT. -- FOOT	SF -- SQUARE FEET
● -- AT	GA. -- GAGE	SHT. -- SHEET
BSMT. -- BASEMENT	GALV. -- GALVANIZED	SIM. -- SIMILAR
BITUM. -- BITUMINOUS	GR. -- GRADE	SJ -- STEEL JOIST
B/ -- BOTTOM OF	GRD. -- GROUND	SLBB -- SHORT LEG BACK-TO-BACK
BOT. -- BOTTOM	GRT. -- GRATING	SLV -- SHORT LEG VERTICAL
ℓ -- BUILDING LINE	GYP BD-- GYPSUM BOARD	SPA. -- SPACES OR SPACING
BLDG. -- BUILDING	HORIZ. -- HORIZONTAL	SPRD. -- SPREAD
BLK. -- BLOCK	HP -- HIGH POINT	ST STL -- STAINLESS STEEL
BM -- BEAM	HR. -- HANDRAIL	STA. -- STATION
B PL -- BASE PLATE	HT. -- HEIGHT	STD. -- STANDARD
BRG. -- BEARING	ID -- INSIDE DIAMETER	STL. -- STEEL
BUR -- BUILT-UP ROOF	IF -- INSIDE FACE	STRUCT. -- STRUCTURAL
C/C -- CENTER TO CENTER	INT. -- INTERIOR	SUP. -- SUPPORT
CJ -- CONTROL JOINT	INV. -- INVERT	SYM. -- SYMMETRICAL
Ⓢ -- CENTERLINE OR COLUMN LINE	INSUL. -- INSULATION	T. -- TREAD
CLR. -- CLEAR	JT. -- JOINT	T/ -- TOP OF
CMU -- CONCRETE MASONRY UNIT	K. -- KIP (1000 POUNDS)	T&B -- TOP AND BOTTOM
COL. -- COLUMN	L -- ANGLE (STRUCTURAL SHAPE)	TEMP. -- TEMPORARY
CTR. -- CENTER	LB. -- POUNDS	THK. -- THICK
CONC. -- CONCRETE	LL -- LIVE LOAD	TOM -- TOP OF MASONRY
CONST. -- CONSTRUCTION	LLBB -- LONG LEG BACK-TO-BACK	TOS -- TOP OF STEEL
CONT. -- CONTINUOUS	LG. -- LONG	TYP. -- TYPICAL
DEPR. -- DEPRESSION	LLH -- LONG LEG HORIZONTAL	UON -- UNLESS OTHERWISE NOTED
DET. -- DETAIL	LLV -- LONG LEG VERTICAL	VERT. -- VERTICAL
DI -- DUCTILE IRON	LONG. -- LONGITUDINAL	W/ -- WITH
DIA. -- DIAMETER	LP -- LOW POINT	W. -- WEST
DIM. -- DIMENSION	LW -- LIGHT WEIGHT	W/O -- WITHOUT
DL -- DEAD LOAD	MFG. -- MANUFACTURER	WP -- WORK POINT
DIST. -- DISTANCE	MAS. -- MASONRY	WT. -- WEIGHT
DS -- DOWNSPOUT	MAT'L -- MATERIAL	
DWG. -- DRAWING	MAX. -- MAXIMUM	
DWL -- DOWEL	MIN. -- MINIMUM	
EA. -- EACH	MK. -- MARK	
EE -- EACH END	MO -- MASONRY OPENING	
EF -- EACH FACE	NA -- NOT APPLICABLE	
EJ -- EXPANSION JOINT	N. -- NORTH	
EL. -- ELEVATION	#, NO. -- NUMBER	
ELEC. -- ELECTRICAL	NTS -- NOT TO SCALE	
E. -- EAST	OC -- ON CENTER	
EMBD. -- EMBEDDED	OD -- OUTSIDE DIAMETER	
EW -- EACH WAY	OH. -- OVERHEAD	
EWC -- ELECTRIC WATER COOLER	OPNG. -- OPENING	
EQ. -- EQUAL	OPP. -- OPPOSITE	
EXIST. -- EXISTING	ℓ -- PLATE	
EXP. -- EXPANSION	PC -- PRECAST	
EXT. -- EXTERIOR	PSF -- POUNDS PER SQUARE FOOT	
	R. -- RISER	
	RAD -- RADIUS	

**SYMBOLS**

	CONCRETE MASONRY		ROOM NUMBER
	CONCRETE		DOOR NUMBER
	GROUT		FIRE EXTINGUISHER
	STEEL		ILLUMINATED EXIT SIGN LOCATION
	EARTH		
	RIGID INSULATION		
	GRATING		

**GENERAL NOTES:**

- REFER TO MASONRY GENERAL NOTES ON SHEET GS-1 FOR ADDITIONAL REQUIREMENT FOR MASONRY REINFORCING AND MATERIALS.
- ITEMS NOTED ON THE DRAWINGS SHALL BE CONSIDERED THE SAME AS NOTED ITEMS WHICH ARE GRAPHICALLY REPRESENTED IN THE SAME MANNER.
- BUILDING TO COMPLY WITH STATE AND LOCAL BUILDING CODES.
- CONTRACTOR TO COORDINATE ALL MECHANICAL, ELECTRICAL, ETC. OPENINGS. FOR CONCRETE AND STEEL SIZES SEE STRUCTURAL DRAWINGS.
- DIMENSIONS ARE NOMINAL. CONTRACTOR TO COORDINATE ACTUAL DIMENSIONS.
- SEE MECHANICAL DRAWINGS FOR ADDITIONAL NOTES.
- ALL INTERIOR CONCRETE MASONRY BLOCK WALLS, EXPOSED STEEL, AND OTHER MATERIALS TO BE PAINTED PER SPEC SECTION 09900.
- (\*) INDICATES FIELD VERIFY
- ALL CELLS OF MASONRY BLOCK CONTAINING REINFORCING BARS SHALL BE GROUTED SOLID FULL HEIGHT AND WIDTH.
- ALL INTERIOR MASONRY WALLS SHALL EXTEND TO UNDERSIDE OF THE ROOF ABOVE. PROVIDE MASONRY ANCHORS FROM THE TOP COURSE OF ALL INTERIOR MASONRY WALLS AS SHOWN.
- THE SYMBOLS AND ABBREVIATIONS LIST ON THIS SHEET IS A COMPREHENSIVE STANDARD GUIDE INTENDED FOR GENERAL USE ON ALL PROJECT. THEREFORE NOT ALL THE SYMBOLS AND ABBREVIATIONS CONTAINED IN THE LIST ARE NECESSARILY USED ON THIS PARTICULAR PROJECT.

**BUILDING CODE SUMMARY  
UV BUILDING**

THE FOLLOWING CODE SUMMARY IS BASED ON THE 2007 CALIFORNIA BUILDING CODE.

- PROJECTS DESCRIPTION  
FLOOR AREA:  
UV REACTOR ROOM -- 690 SF  
ELECTRICAL ROOM -- 697 SF  
TOTAL -- 1387 SF  
HEIGHT: 11'-8"
- BUILDING USE AND OCCUPANCY CLASSIFICATION : CHAPTER 3  
F-2: LOW HAZARD (FACTORY)
- CONSTRUCTION CLASSIFICATION (CHAPTER 6)  
CONSTRUCTION TYPE: II-B: NON-COMBUSTABLE MATERIALS
- MEANS OF EGRESS (CHAPTER 10):  
MAXIMUM FLOOR AREA ALLOWANCES PER OCCUPANT (TABLE 1004.1.1)  
ACCESSORY STORAGE AREAS, MECHANICAL EQUIPMENT ROOMS:  
300 SF GROSS  
DESIGN OCCUPANT LOAD:  
1387 SF / 300 SF = 4  
EXIT ACCESS TRAVEL DISTANCE -- WITHOUT SPRINKLERS (TABLE 1016.1) F-2: 300 FT

XREFS: \\XREF\MOPUVF.dwg ... \XREF\SGPUVF.dwg ... \XREF\5324-TBLK.dwg IMAGES: None User: Regensc. Spec: PIRNIE\_STANDARD File: C:\5324002\Covina\ARCH\5324A226.DWG Scale: 1:1 Date: 06/30/2009 Time: 18:14 Layout: A01



REVISIONS			
NO.	BY	DATE	REMARKS

DES	SRZ
DWN	CSR
CRD	FJB

COVINA IRRIGATING COMPANY  
GLEN DORA, CALIFORNIA  
**UV/CHLORAMINES FOR TEMPLE WTP**

TEMPLE WATER TREATMENT PLANT  
**SYMBOLS, ABBREVIATIONS AND  
GENERAL NOTES**  
SCALE: NO SCALE

COPYRIGHT © 2009  
MALCOLM PIRNIE, INC.  
DATE DECEMBER 2009  
A SHEET 1 OF 5  
CAD REF. NO. 5324A226



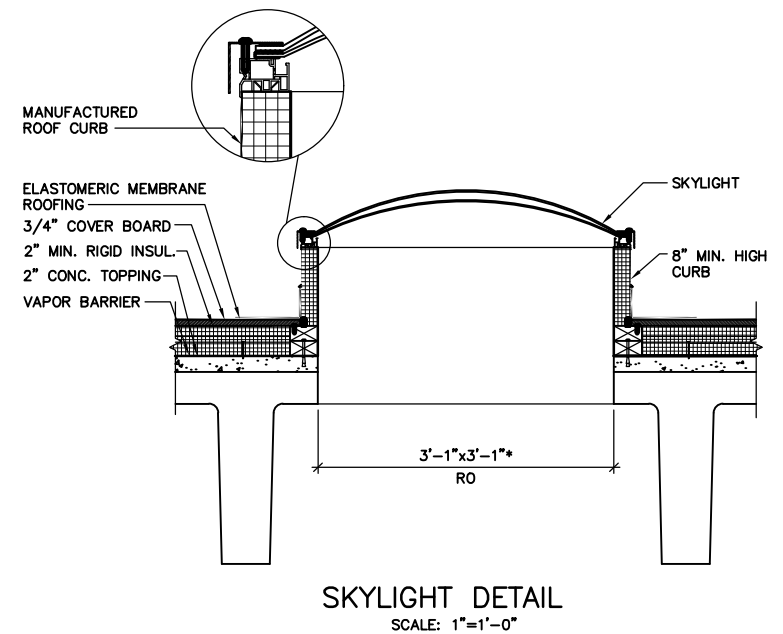
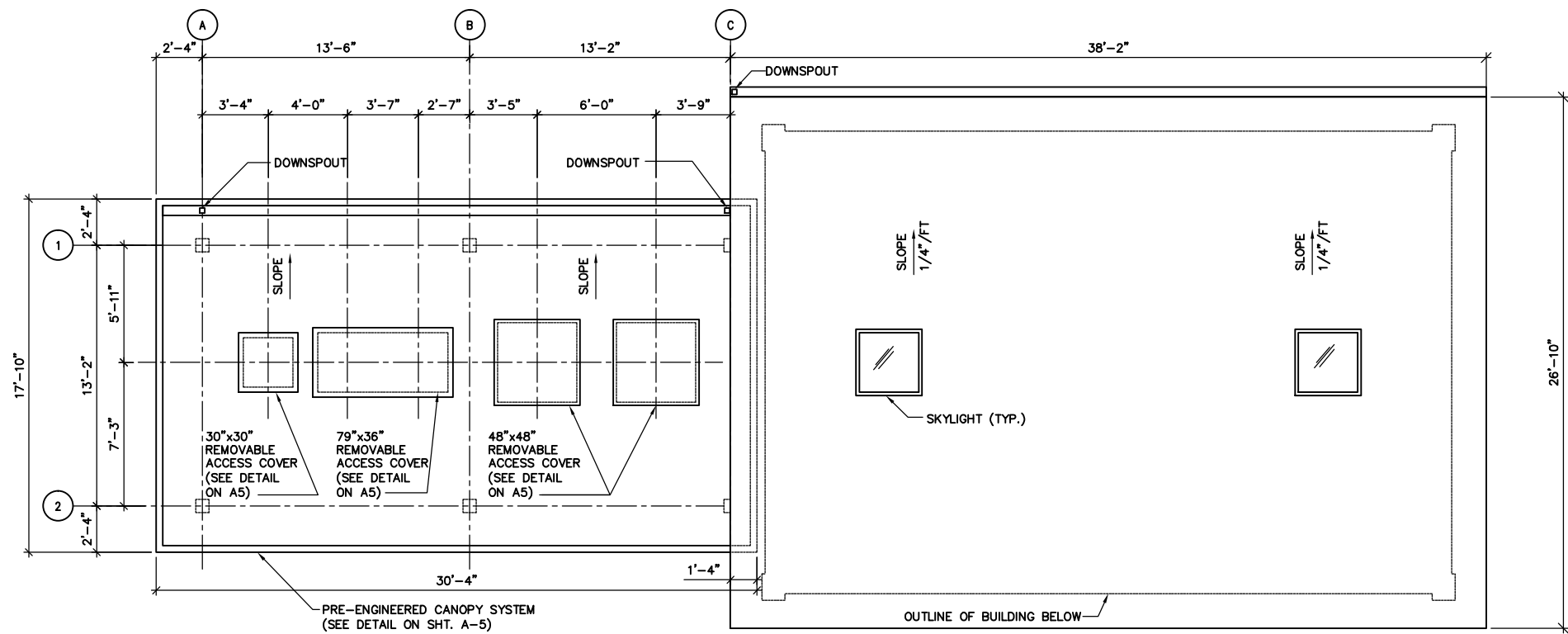

**NOTE:**  
 ACCESS HATCHES SHALL BE SIZED TO PROVIDE SUFFICIENT CLEAR OPENING TO REMOVE VERTICAL TURBINE PUMPS BELOW. ACTUAL DIMENSIONS OF ACCESS HATCHES SHALL BE COORDINATED WITH PUMP AND CANOPY MANUFACTURERS.

ROOF PLAN

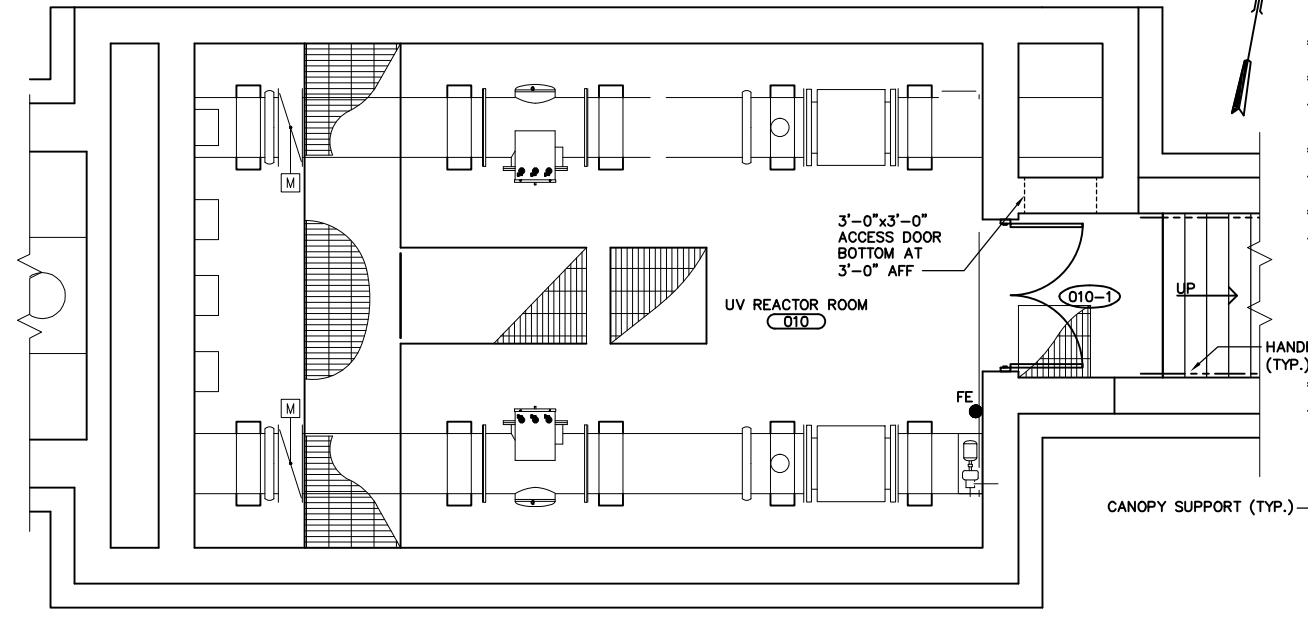

LOWER LEVEL PLAN AT EL 665.00

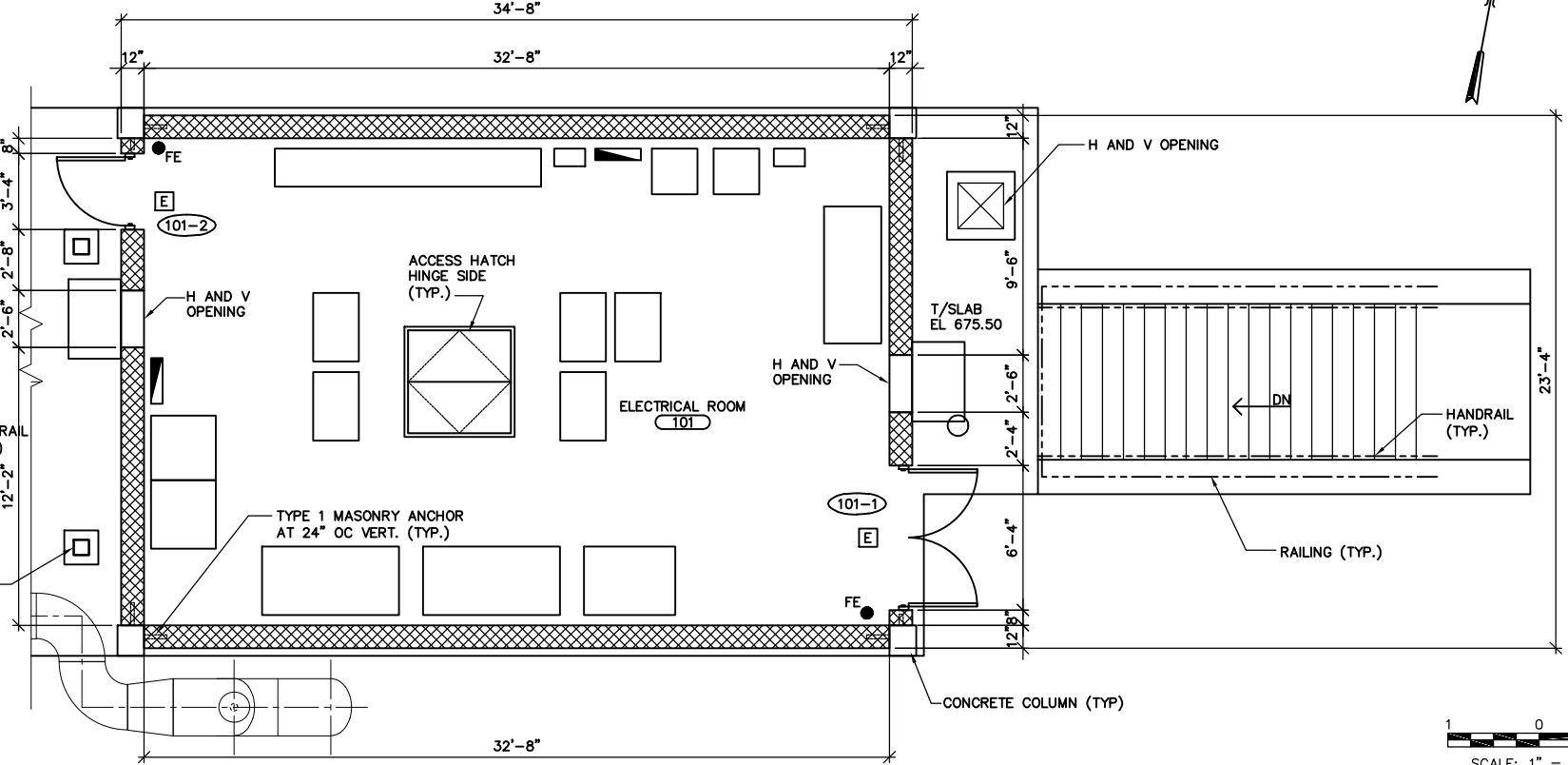

FLOOR PLAN AT EL 675.50

**NOTES:**  
 1. FOR DOOR SCHEDULE SEE SHEET A-5  
 2. PAINT ALL INTERIOR CONCRETE MASONRY WALLS

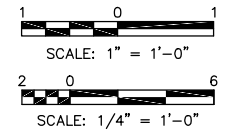

NO.	BY	DATE	REVISIONS	REMARKS

DES SRZ  
 DWN CSR  
 CRD FJB

COVINA IRRIGATING COMPANY  
 GLENDORA, CALIFORNIA  
**UV/CHLORAMINES FOR TEMPLE WTP**

TEMPLE WATER TREATMENT PLANT  
**UV FACILITY – ELECTRICAL ROOM  
 BUILDING PLANS**  
 SCALE: 1/4"=1'-0"

COPYRIGHT © 2009  
 MALCOLM PIRNIE, INC.  
 DATE DECEMBER 2009  
 A SHEET 2 OF 5  
 CAD REF. NO. 5324A227

XREFS: \\VREF\MGPIV.dwg; \\VREF\SGPIV.dwg; \\VREF\5324-TBLK.dwg; IMAGES: None  
 User: Rpgreac; Spec: PIRNIE\_STANDARD; File: C:\5324002\_CovIno\ARCH\5324A227.DWG; Scale: 1:1; Date: 06/30/2009; Time: 18:13; Layout: A02

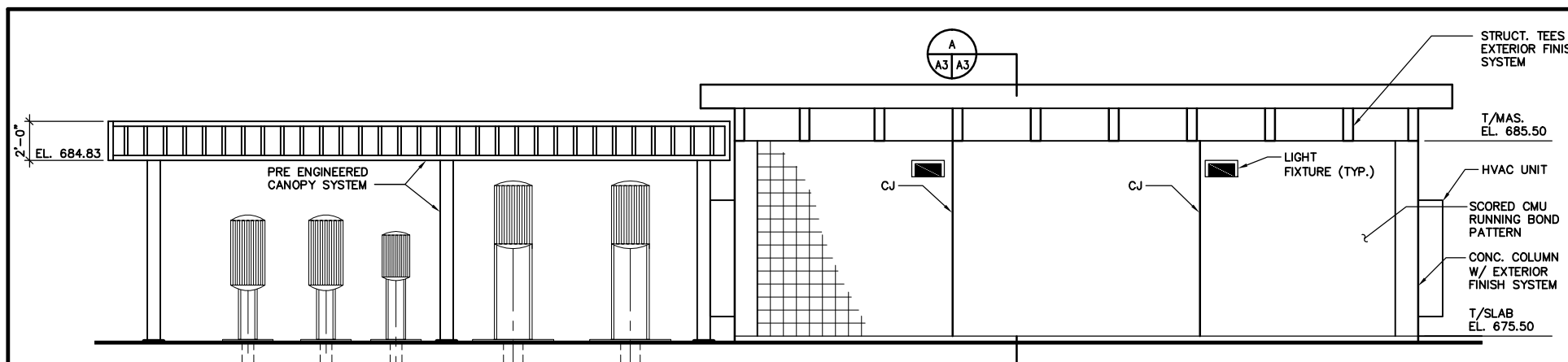

**SOUTH ELEVATION**  
SCALE: 1/4"=1'-0"

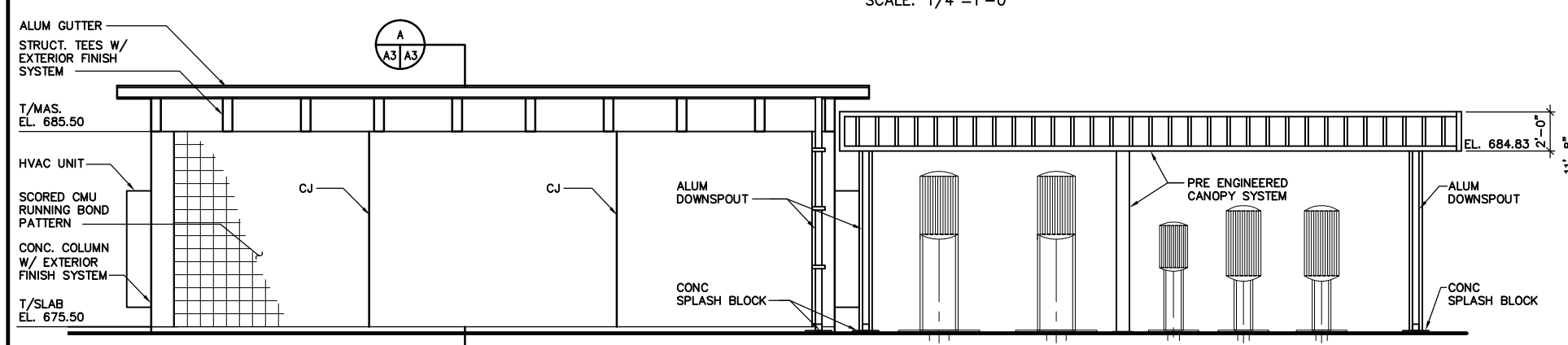

**NORTH ELEVATION**  
SCALE: 1/4"=1'-0"

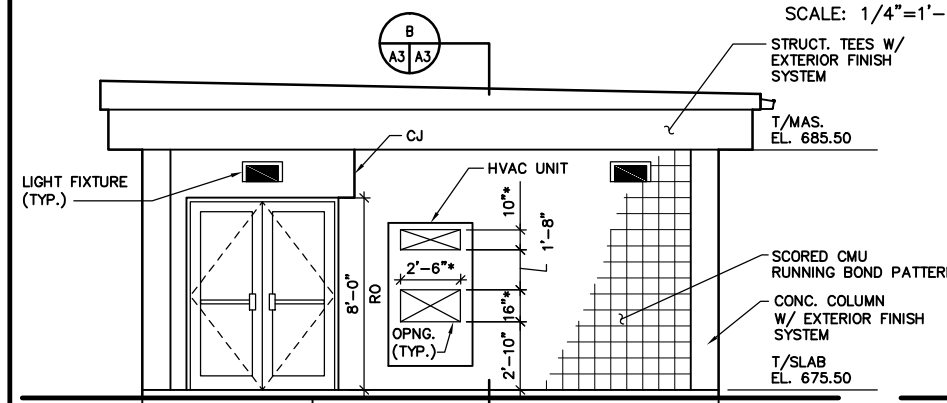

**EAST ELEVATION**  
SCALE: 1/4"=1'-0"

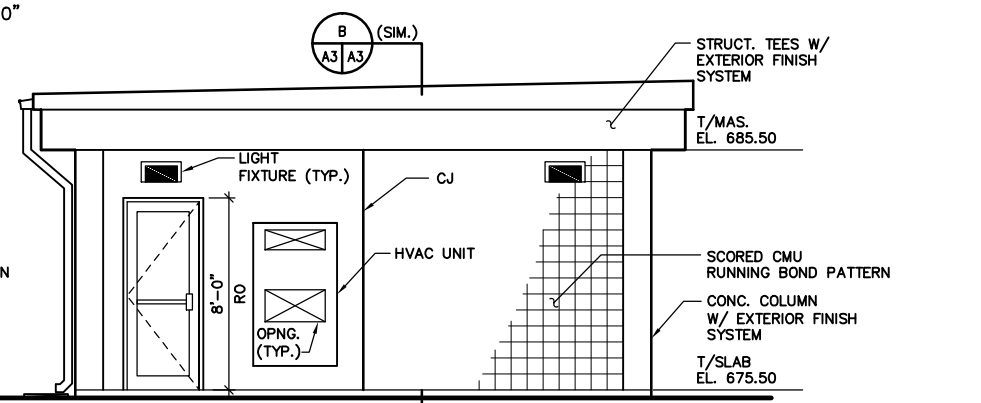

**WEST ELEVATION**  
SCALE: 1/4"=1'-0"

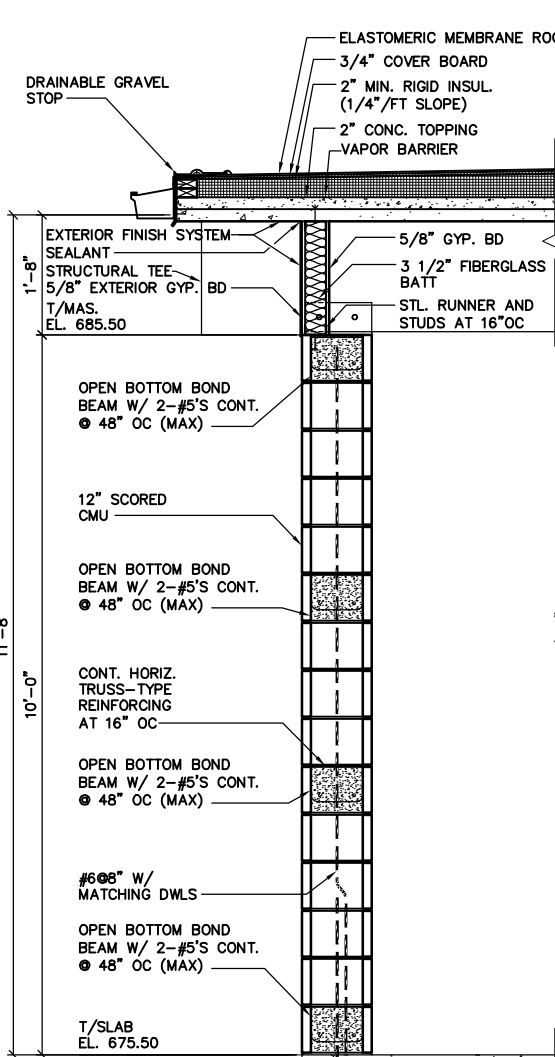

**SECTION A/A3/A3**  
SCALE: 3/4"=1'-0"

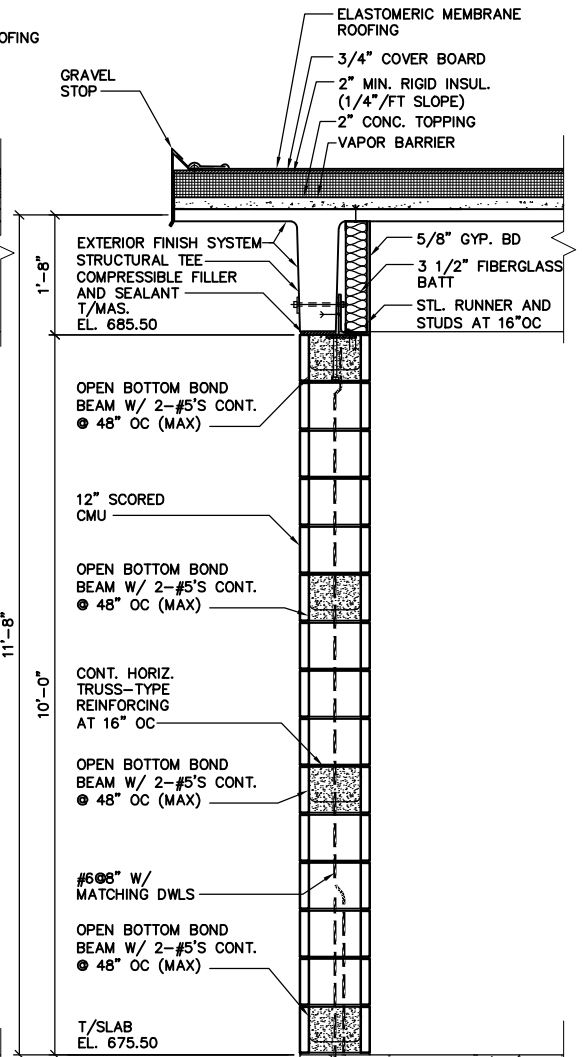

**SECTION B/A3/A3**  
SCALE: 3/4"=1'-0"

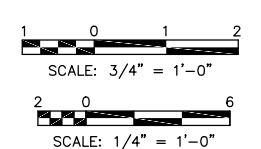

XREFS: \\P\REF\MOPUV.dwg ... \REF\SGPUV.dwg ... \REF\5324-TBLK.dwg IMAGES: None  
 User: Rpgarsc, Spec: PIRNIE, STANDARD, File: c:\5324002, Covna\ARCH\5324A228.DWG, Scale: 1:1, Date: 06/30/2009, Time: 18:12, Layout: A03



NO.	BY	DATE	REVISIONS	REMARKS

DES SRZ  
DWN CSR  
CRD FJB

COVINA IRRIGATING COMPANY  
GLENORA, CALIFORNIA  
**UV/CHLORAMINES FOR TEMPLE WTP**

TEMPLE WATER TREATMENT PLANT  
**UV FACILITY ELECTRICAL ROOM**  
**ELEVATIONS AND WALL SECTIONS**  
SCALE: AS NOTED

COPYRIGHT © 2009  
MALCOLM PIRNIE, INC.  
DATE DECEMBER 2009  
A SHEET 3 OF 5  
CAD REF. NO. 5324A228

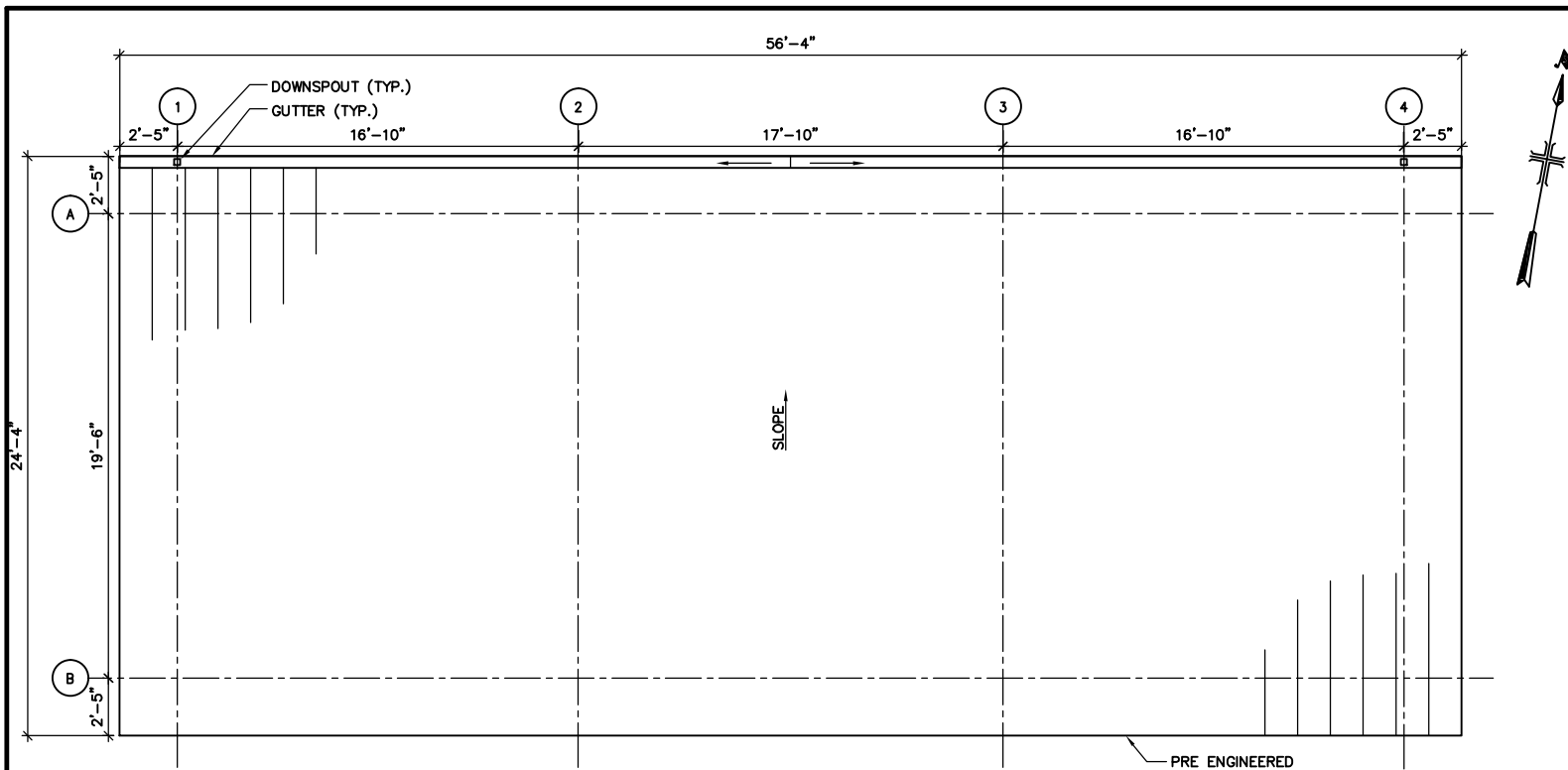

**ROOF PLAN**  
SCALE: 1/4"=1'-0"

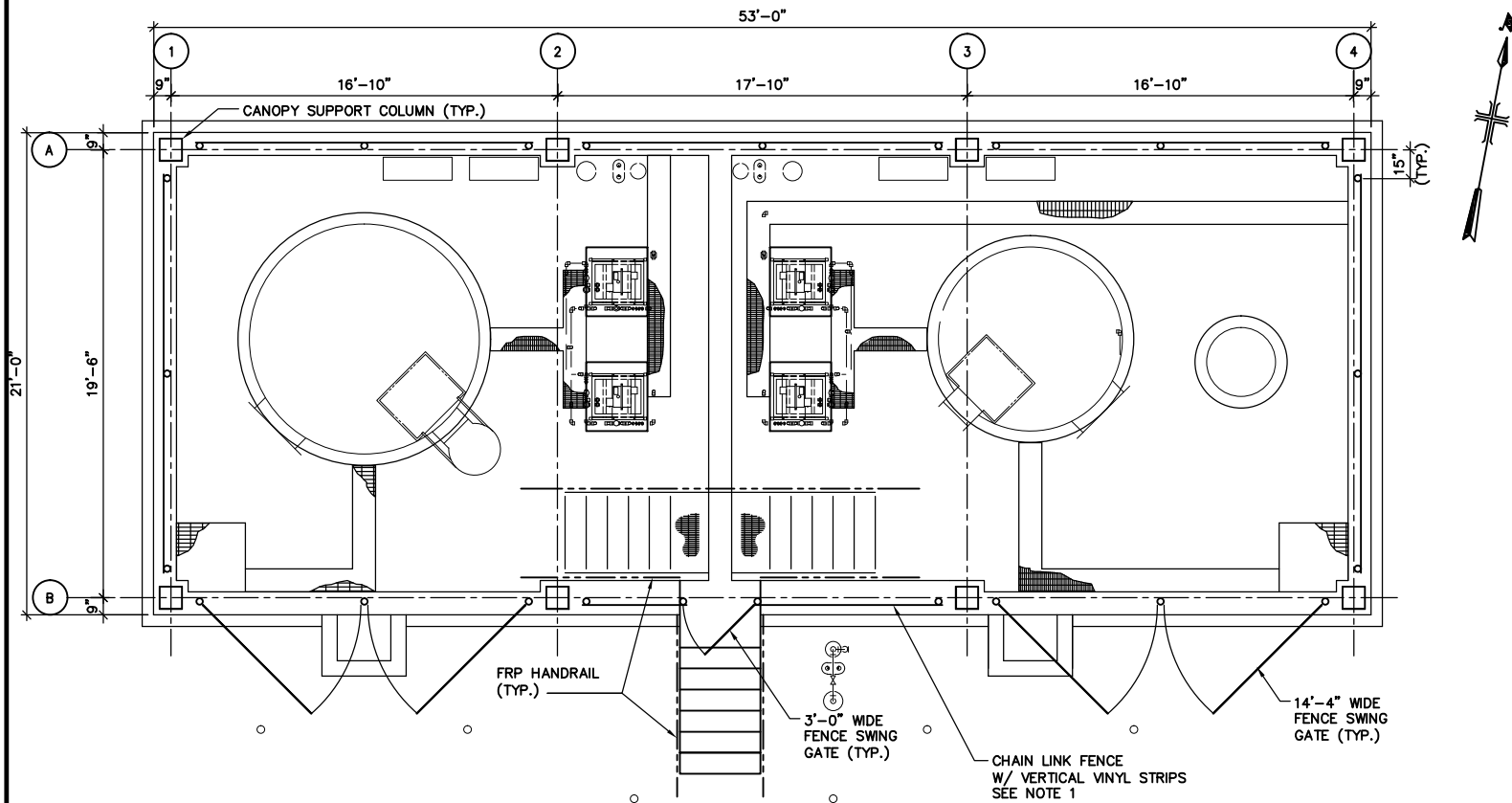

**PLAN**  
SCALE: 1/4"=1'-0"

NOTE:  
1. SPACE FENCE POSTS AS GENERALLY SHOWN, MAXIMUM 8'-6" OC. PROVIDE DIAGONAL TIES AND HORIZONTAL BARS AS REQUIRED. SEE ANCHOR DETAILS ON SHEET GC-2.

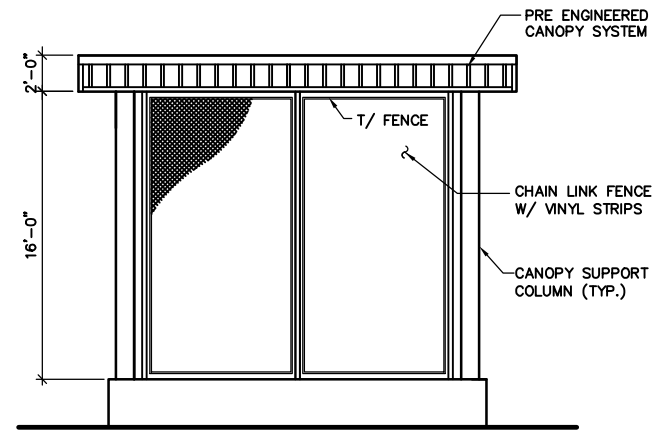

**WEST ELEVATION**  
SCALE: 3/16"=1'-0"

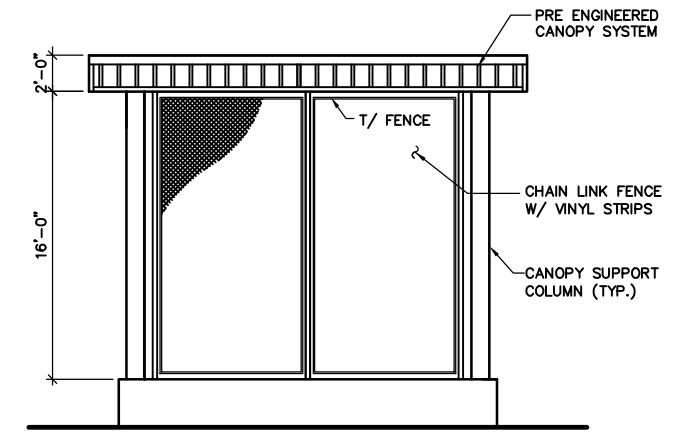

**EAST ELEVATION**  
SCALE: 3/16"=1'-0"

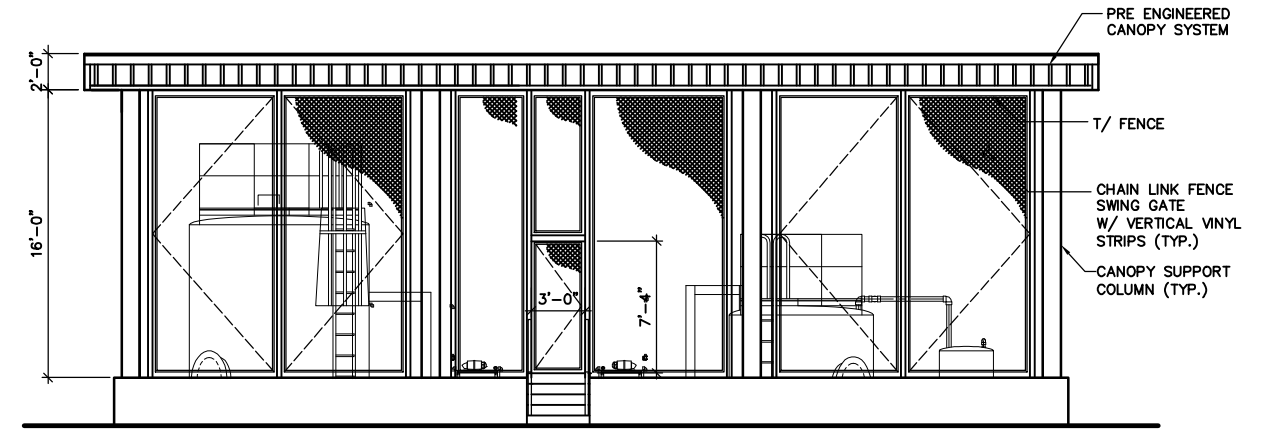

**SOUTH ELEVATION**  
SCALE: 3/16"=1'-0"

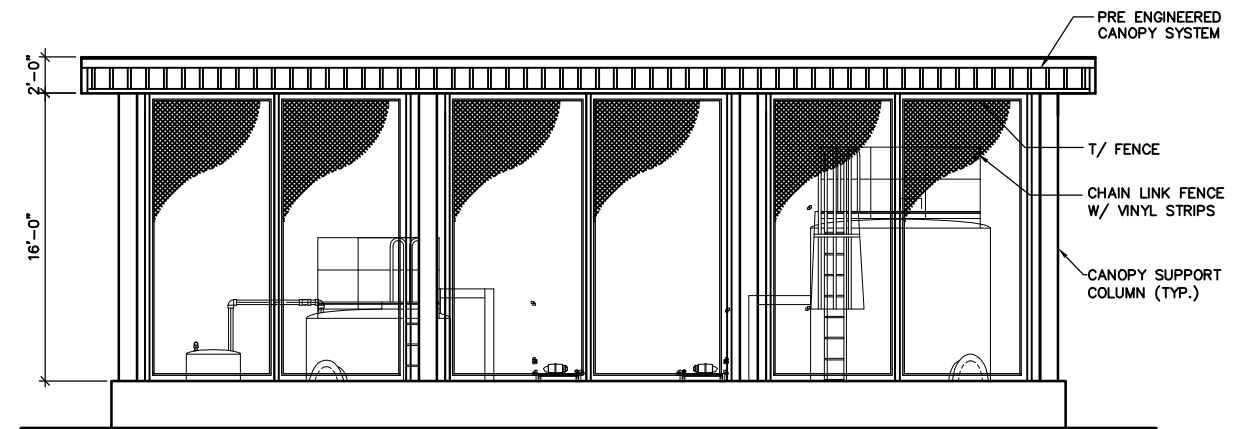

**NORTH ELEVATION**  
SCALE: 3/16"=1'-0"

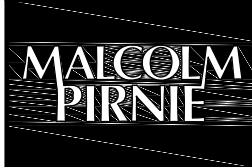

REVISIONS		DES	SRZ
NO.	BY	DATE	REMARKS

COVINA IRRIGATING COMPANY  
GLEN DORA, CALIFORNIA  
**UV/CHLORAMINES FOR TEMPLE WTP**

TEMPLE WATER TREATMENT PLANT  
**CHEMICAL FACILITY PLANS  
AND CANOPY ELEVATIONS**  
SCALE: 1/4"=1'-0"

COPYRIGHT © 2009  
MALCOLM PIRNIE, INC.  
DATE: DECEMBER 2009  
A SHEET 4 OF 5  
CAD REF. NO. 5324A230

XREFS: \\XREF\MGP\UVF.dwg; \\XREF\SGPUV.dwg; \\XREF\5324-TBLK.dwg; IMAGES: None; User: Rpgarsc; Spec: PIRNIE\_STANDARD; File: C:\5324002\CovIno\ARCH\5324A230.DWG; Scale: 1:1; Date: 06/30/2009; Time: 18:08; Layout: A04

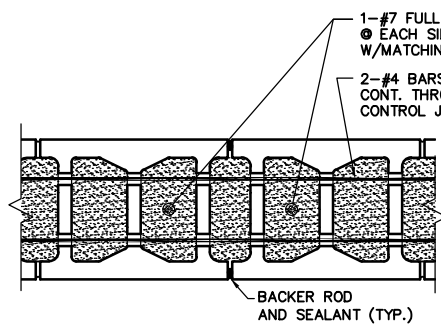

**CONTROL JOINT DETAIL AT BOND BEAM**

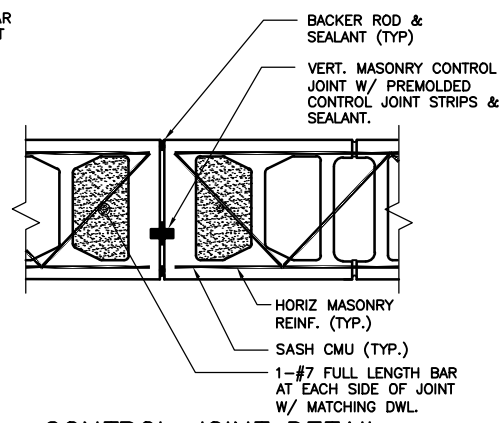

**CONTROL JOINT DETAIL**

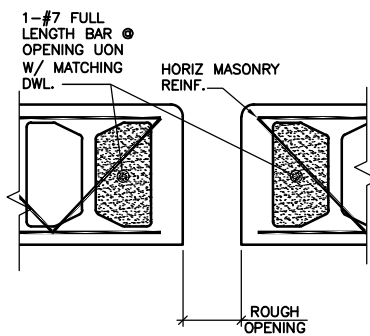

**TYPICAL MASONRY OPENING DETAIL**

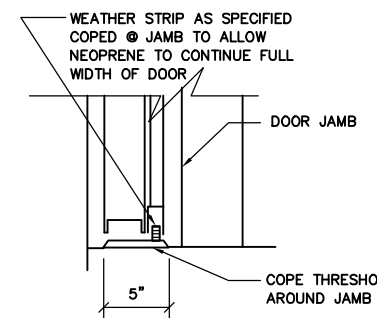

**EXTERIOR DOOR THRESHOLD**

DOOR SCHEDULE													
DOOR NO.	ROUGH OPNG		DOOR				DETAILS		FRAME		HARDWARE SET	U.L. LABEL	REMARKS
	WIDTH	HEIGHT	WIDTH	HEIGHT	TYPE	MATL TYPE	HEAD	JAMB	TYPE	MATL			
<b>UV FACILITY - ELECTRICAL ROOM BUILDING</b>													
010-1	6'-4"	8'-0"	(2) 3'-0"	7'-10"	B&C	HM	B	B	B	HM	3	-	NO THRESHOLD
101-1	6'-4"	8'-0"	(2) 3'-0"	7'-10"	B	HM	A	A	B	HM	2	-	
101-2	3'-4"	8'-0"	3'-0"	7'-10"	B	HM	A	A	A	HM	1	-	

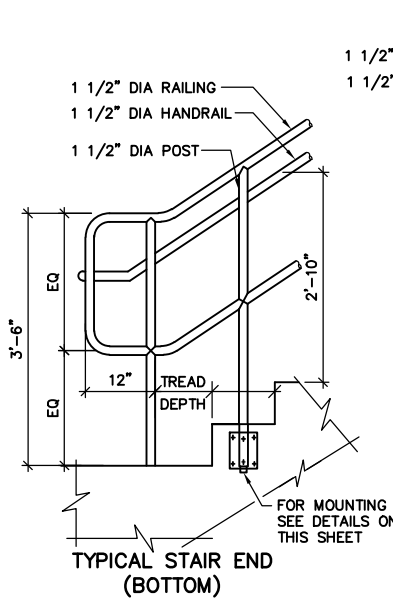

**TYPICAL STAIR END (BOTTOM)**

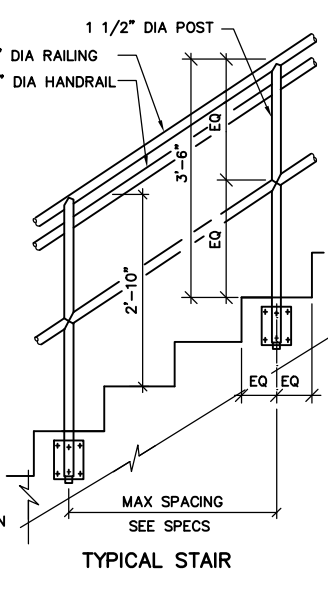

**TYPICAL STAIR**

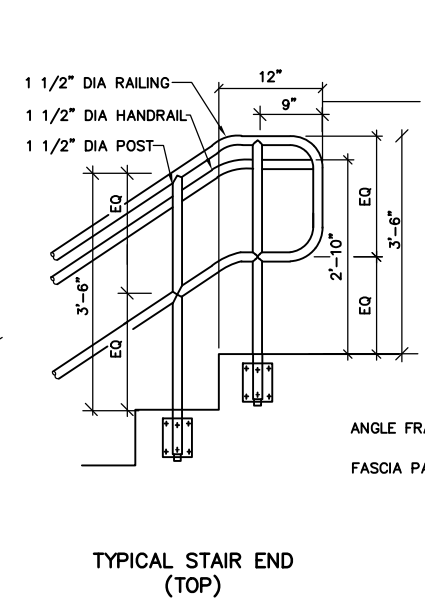

**TYPICAL STAIR END (TOP)**

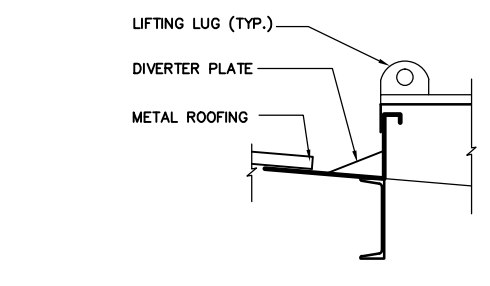

**REMOVABLE ACCESS COVER DETAIL AT CANOPY**

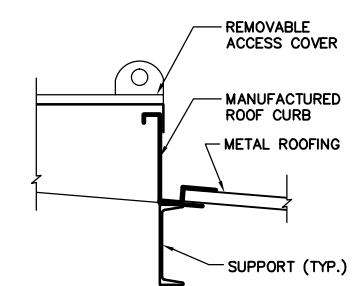

**SECTION A-A**

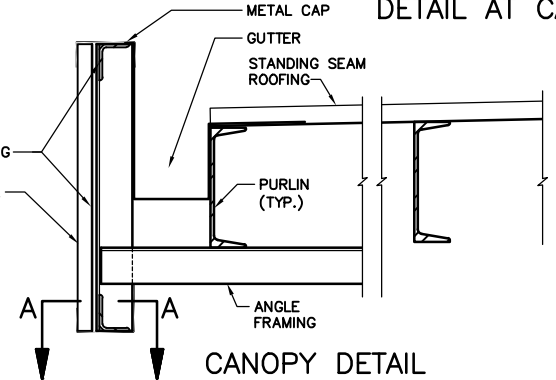

**CANOPY DETAIL**

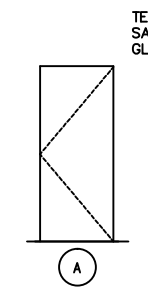

**DOOR TYPE**

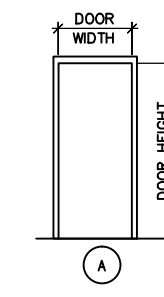
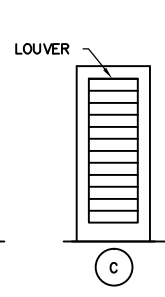
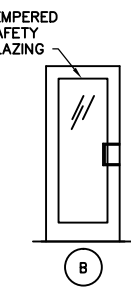

**FRAME TYPE**

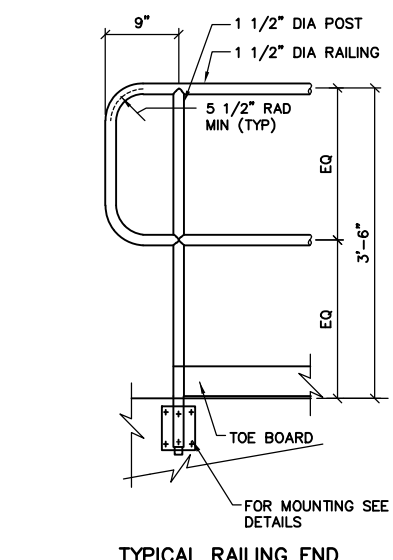
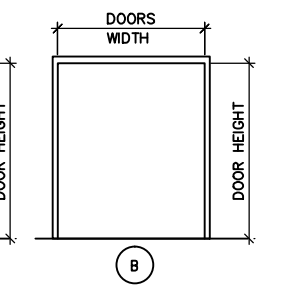

**TYPICAL RAILING END**

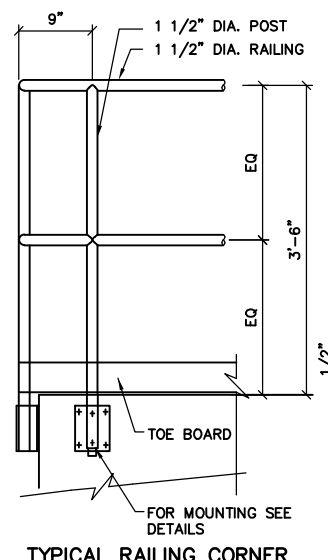

**TYPICAL RAILING CORNER**

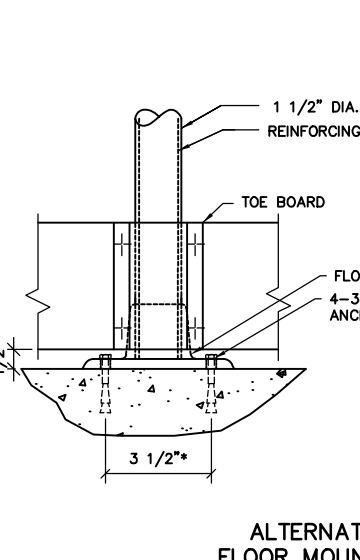

**ALTERNATE FLOOR MOUNTED**

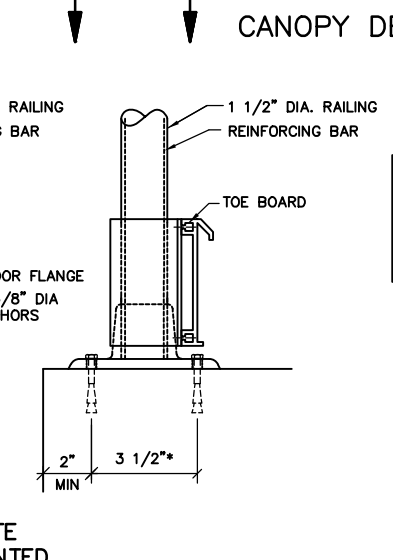

**STANDARD SIDE MOUNT DETAIL**

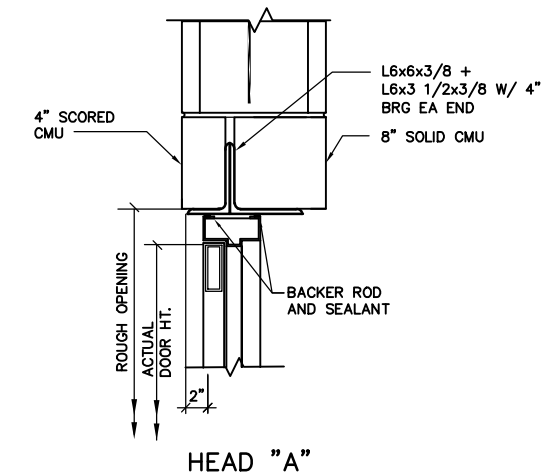

**HEAD "A"**

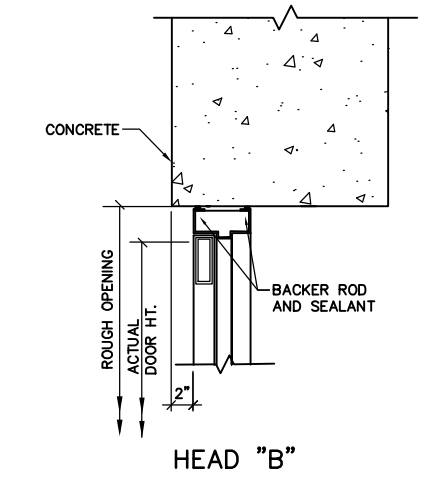

**HEAD "B"**

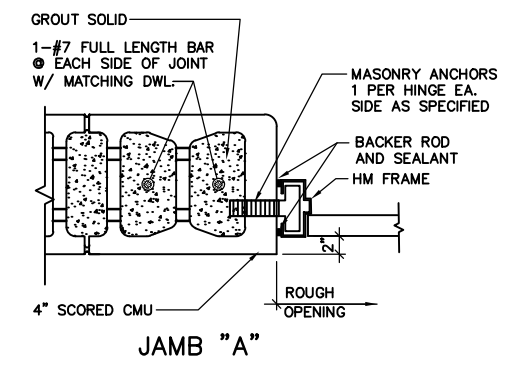

**JAMB "A"**

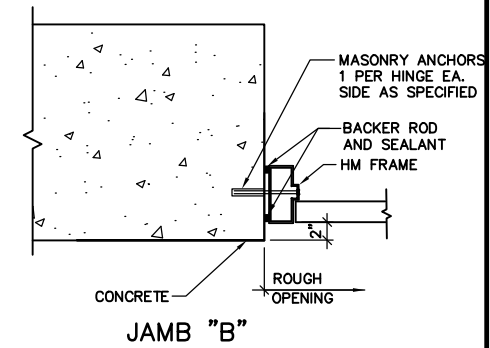

**JAMB "B"**

**TYPICAL ALUMINUM RAILING AND HANDRAIL DETAILS**

User: Regenc Spec: PIRNIE\_STANDARD File: C:\3244229.DWG Scale: 1:1 Date: 06/30/2009 Time: 18:10 Layout: A05



REVISIONS			
NO.	BY	DATE	REMARKS

DES SRZ  
 DWN CSR  
 CRD FJB

COVINA IRRIGATING COMPANY  
 GLENDORA, CALIFORNIA

**UV/CHLORAMINES FOR TEMPLE WTP**

TEMPLE WATER TREATMENT PLANT

**DOOR SCHEDULE AND DETAILS**

SCALE: NO SCALE

COPYRIGHT © 2009 MALCOLM PIRNIE, INC.  
 DATE DECEMBER 2009

A SHEET 5 OF 5  
 CAD REF. NO. 5324A229

GENERAL

- G-1 THESE NOTES ARE GENERAL AND SUPPLEMENTAL TO THE SPECIFICATONS. THESE NOTES APPLY TO THE ENTIRE PROJECT UNLESS MODIFIED OR NOTED OTHERWISE IN THE CONTRACT DOCUMENTS.
G-2 STANDARD DETAILS, SHOWN ON DRAWINGS GS-2 AND GS-3 SHALL BE USED WHEN REFERRED TO, OR WHEN LESS RESTRICTIVE OR DIFFERENT DETAILS ARE SHOWN ON THE DRAWINGS.
G-3 DESIGN IS IN ACCORDANCE WITH AND CONSTRUCTION SHALL COMPLY WITH THE PROVISIONS OF CALIFORNIA UNIFORM STATEWIDE BUILDING CODE (CSBC)-LATEST EDITION, EXCEPT WHERE OTHER APPLICABLE CODES AND THE CONTRACT DOCUMENTS ARE MORE RESTRICTIVE.
G-4 LIVE LOADS: AS SHOWN ON DRAWINGS.
G-5 ROOF SNOW LOAD:
1. GROUND SNOW LOAD, Pg = 5 PSF
G-6 SEISMIC LOAD DATA:

MAPPED SPECTRAL RESPONSE ACCELERATIONS
Sa = 205.6%
Si = 73.2%
SITE CLASS
"D"
SPECTRAL RESPONSE COEFFICIENTS
Sds = 137.1%
Sd1 = 73.2%
SEISMIC DESIGN CATEGORY
"D"
IMPORTANCE FACTOR = 1.25
ANALYSIS PROCEDURE: "EQUIVALENT LATERAL FORCE PROCEDURE."

- G-7 WIND DESIGN DATA:
1. BASIC WIND SPEED: 85 MPH
2. WIND IMPORTANCE FACTOR: 1.15, BUILDING CATEGORY: III
3. WIND EXPOSURE: C
4. APPLICABLE INTERNAL PRESSURE COEFFICIENT = 0.18
5. DESIGN WIND PRESSURE, COMPONENT AND CLADDING = 45 PSF
G-8 ALL DIMENSIONS INDICATED (\*) ARE TO BE VERIFIED EITHER BY FIELD MEASUREMENTS FOR EXISTING STRUCTURES OR BY SHOP DRAWINGS FOR EQUIPMENT FURNISHED. STRUCTURAL DIMENSIONS NOT SHOWN BUT CONTROLLED BY OR RELATED TO EQUIPMENT SHALL BE VERIFIED BY THE CONTRACTOR WITH THE MANUFACTURER PRIOR TO CONSTRUCTION.
G-9 EQUIPMENT ANCHOR BOLT SIZES, TYPES, AND PATTERNS SHALL BE VERIFIED WITH THE MANUFACTURER. ALL BOLT PATTERNS SHALL BE TEMPLATED TO INSURE ACCURACY OF PLACEMENT.
G-10 STRUCTURAL DRAWINGS SHALL BE USED IN COORDINATION WITH DRAWINGS OF ALL OTHER DISCIPLINES AND MANUFACTURER'S SHOP DRAWINGS.
G-11 IF A CONFLICT IS FOUND BETWEEN DIFFERENT PORTIONS OF THE CONTRACT DOCUMENTS, THE CONTRACTOR SHALL NOTIFY THE OWNER IMMEDIATELY. CONTINUED CONSTRUCTION OF THE AREA IN CONFLICT SHALL BE AT THE CONTRACTOR'S OWN RISK UNTIL THE CONFLICT IS RESOLVED BY THE OWNER.
G-12 STRUCTURES HAVE BEEN DESIGNED FOR OPERATIONAL LOADS ON THE COMPLETED STRUCTURE. DURING CONSTRUCTION, THE STRUCTURES SHALL BE PROTECTED BY BRACING AND TEMPORARY SUPPORTS WHEREVER EXCESSIVE CONSTRUCTION LOADS MAY OCCUR. OVERSTRESSING OF ANY STRUCTURAL ELEMENT IS PROHIBITED.
G-13 NO BACKFILL SHALL BE PLACED AGAINST ANY WALL UNLESS ALL SUPPORTING ELEMENTS OF THE STRUCTURE HAVE BEEN CONSTRUCTED AND HAVE REACHED THE SPECIFIED MINIMUM CONCRETE STRENGTH.
G-14 DO NOT SCALE THESE DRAWINGS, USE DIMENSIONS.

GENERAL (CON'T)

- G-15 CONTRACTOR'S CONSTRUCTION AND/OR ERECTION SEQUENCES SHALL RECOGNIZE AND CONSIDER THE EFFECTS OF THERMAL MOVEMENTS OF STRUCTURAL ELEMENTS DURING THE CONSTRUCTION PERIOD.
G-16 WHERE CONNECTIONS TO OR MODIFICATIONS OF EXISTING STRUCTURES ARE SHOWN, EXISTING FOUNDATIONS, WALLS, COLUMNS, SLABS, BEAMS, FLOORS, DECKS, (CONCRETE, STEEL, TIMBER, ETC) ARE ASSUMED TO BE IN GOOD CONDITION. THIS MUST BE VERIFIED IN THE FIELD BY THE CONTRACTOR. UNSOUND CONDITIONS SHALL BE REPORTED TO THE OWNER. ALL UNSOUND STRUCTURAL ELEMENTS SHALL BE REPAIRED TO SOUND CONDITION AS APPROVED BY THE OWNER. EXISTING CONSTRUCTION: DIMENSIONS SHALL BE VERIFIED BY THE GENERAL CONTRACTOR BEFORE WORK COMMENCES. VARIATIONS FROM DIMENSIONS SHOWN ON THESE DRAWINGS SHALL BE REPORTED TO THE OWNER.
G-17 NO COLD WEATHER CONSTRUCTION OR HOT WEATHER CONSTRUCTION, AS DEFINED IN SPECIFICATION SECTION 03300, IS PERMITTED WITHOUT WRITTEN APPROVAL OF THE OWNER.
G-18 OPENINGS AND PENETRATIONS: THE CONTRACTOR SHALL SUBMIT COMPOSITE DRAWINGS INDICATING ALL FLOOR OPENINGS AND PENETRATIONS THROUGH STRUCTURAL MEMBERS REQUIRED TO ACCOMMODATE THE HVAC, PLUMBING AND ELECTRICAL WORK. THE CONTRACTOR SHALL FOLLOW THE TYPICAL FRAMING DETAILS AT OPENINGS AND REINFORCEMENT DETAILS AT PENETRATIONS THROUGH STRUCTURAL MEMBERS. ACCORDINGLY, THE CONTRACTOR SHALL SUBMIT SHOP DETAILS TO THE OWNER FOR THE REVIEW.

FOUNDATIONS

- F-1 DESIGN ASSUMPTIONS:
A) ALLOWABLE BEARING PRESSURE: 5000 PSF.
F-2 CONCRETE GENERAL NOTES APPLY TO FOUNDATIONS.
F-3 MINIMUM DEPTH FROM ADJACENT FINISHED GRADE TO BOTTOM OF FOUNDATION 2'-0" UON

CONCRETE

- C-1 CONCRETE 28-DAY COMPRESSIVE STRENGTH:
CLASS A - 4500 PSI; CLASS AS - 4500 PSI
CLASS B - 3000 PSI
C-2 REINFORCEMENT: ASTM A615, GRADE 60, OR ASTM A706, GRADE 60 WHERE REINFORCEMENT IS TO BE WELDED.
C-3 CONCRETE COVER FOR REINFORCING:
A) SURFACES CAST AGAINST SUBGRADE 3" MIN
B) TOP SURFACES OF SLABS WHERE PVC WATERSTOP IS REQUIRED IN WALLS 3" MIN
C) FORMED SURFACES IN CONTACT WITH WEATHER, SOIL, OR LIQUID 2" MIN
D) BOTTOM SURFACES OF SLABS OVER LIQUID 2" MIN
F) SURFACES NOT IN CONTACT WITH WEATHER, SOIL, OR LIQUID 1 1/2" MIN
C-4 CONSTRUCTION JOINTS SHALL BE LOCATED AS SHOWN ON THE DRAWINGS. WHERE NOT SHOWN, CONSTRUCTION JOINTS SHALL BE LOCATED AT NO MORE THAN 40' ON CENTER. CONSTRUCTION JOINT LOCATIONS SHALL BE AS APPROVED BY THE OWNER.
C-5 EQUIPMENT SUPPORTS, ANCHORAGES, OPENINGS, RECESSES AND REVEALS NOT SHOWN ON THE STRUCTURAL DRAWINGS BUT REQUIRED BY OTHER CONTRACT DOCUMENTS, SHALL BE PROVIDED FOR PRIOR TO PLACING CONCRETE.
C-6 AT ALL TYPICAL CURBS, EQUIPMENT PADS, AND PIPE SUPPORT PIERS, REINFORCING DOWELS SHOWN MAY BE REPLACED WITH MATCHING DOWELS SET IN EPOXY IN DRILLED HOLES AS SPECIFIED. DOWELS LOCATED CLOSER THAN 3" FROM ANY EDGE OF CONCRETE SHALL NOT BE REPLACED WITH DRILLED DOWELS.
C-7 WHERE DRILLED EPOXY DOWELS ARE SHOWN TO BE PLACED INTO HARDENED CONCRETE, ADJUST THE DOWEL LOCATIONS AS NEEDED TO AVOID DRILLING THROUGH ANY REINFORCING BARS. IF THE DOWEL LOCATION NEEDS TO BE MODIFIED, CONTACT THE OWNER.
C-8 WHERE HORIZONTAL CONSTRUCTION JOINTS, LOCATED ABOVE THE FOUNDATION SLAB, EXTEND BEYOND WHERE NEEDED, THEY SHALL BE TERMINATED AT A VERTICAL CONSTRUCTION JOINT AS APPROVED BY THE OWNER.
C-9 DOWELS, ANCHOR BOLTS, PIPES, AND OTHER EMBEDDED ITEMS SHALL BE HELD SECURELY IN POSITION WHILE CONCRETE IS BEING PLACED.
C-10 CONDUITS AND PIPES EMBEDDED IN OR PENETRATING THROUGH CONCRETE SHALL BE SPACED ON CENTER NOT LESS THAN 3 TIMES THEIR OUTSIDE DIMENSION, BUT NOT LESS THAN 2 1/2" CLEAR. OUTSIDE DIMENSION OF EMBEDDED ITEMS SHALL NOT EXCEED 1/3 OF THE CONCRETE MEMBER THICKNESS. CLEAR SPACING REQUIREMENTS SHALL APPLY FOR EMBEDDED CONDUITS OR PIPES CROSSING AT AN ANGLE LESS THAN 60 DEGREES.

CONCRETE (CON'T)

- C-11 THE EFFECTIVE DIMENSION USED TO MEET MEMBER THICKNESS LIMITATIONS SHALL BE THE SUM OF THE OUTER DIMENSIONS OF CROSSING ELEMENTS.
C-12 EMBEDDED CONDUITS AND PIPES SHALL BE LOCATED BETWEEN THE LAYERS OF REINFORCEMENT AND A MINIMUM OF 2 1/2" CLEAR FROM APPROXIMATELY PARALLEL REINFORCING BARS. REQUIREMENTS FOR EMBEDDED ELEMENTS CROSSING REINFORCING BARS SHALL BE AS REQUIRED FOR CROSSING EMBEDDED ELEMENTS.
C-13 CONDUITS AND PIPES SHALL NOT BE EMBEDDED IN OR PASS THROUGH COLUMNS OR BEAMS UNLESS INDICATED OTHERWISE OR AUTHORIZED BY OWNER.
C-14 REINFORCING BARS AND ACCESSORIES SHALL NOT BE IN CONTACT WITH ANY METAL PIPE, PIPE FLANGE, METAL CONDUIT, OR OTHER METAL PARTS EMBEDDED IN CONCRETE. A MINIMUM CLEARANCE OF 2 INCHES SHALL BE PROVIDED.
C-15 ALL EXPOSED CORNERS SHALL HAVE A 3/4" CHAMFER OR A 1/2" RADIUS TOOLED CORNER.
C-16 LAP SPLICES SHALL BE IN ACCORDANCE WITH THE TABLE SHOWN ON DRAWING GS-2.

STRUCTURAL STEEL

- 1. STRUCTURAL STEEL SHALL CONFORM TO THE AISC "SPECIFICATIONS FOR DESIGN, FABRICATION AND ERECTION OF STRUCTURAL STEEL FOR BUILDINGS" LATEST EDITION.
2. WELDED CONNECTIONS SHALL CONFORM TO THE LATEST REVISED CODE THE AMERICAN WELDING SOCIETY, AWS D1.
3. BOLTS AND BOLTED CONNECTIONS SHALL CONFORM TO THE REQUIREMENTS OF THE "SPECIFICATIONS FOR STRUCTURAL JOINTS USING ASTM A325 BOLTS" AS APPROVED BY THE COUNCIL ON RIVETED AND BOLTED JOINTS.
4. STRUCTURAL STEEL:
W-SHAPES AND WT-SHAPES . . . . . ASTM A992
CHANNELS . . . . . ASTM A572 GRADE 50
TUBE SECTIONS . . . . . ASTM A500 GRADE B
ANGLES, PLATES AND BARS . . . . . ASTM A36
5. WELDING ELECTRODES SHALL BE E-70XX. FOR WELDING SYMBOLS WITH NO LENGTH DIMENSION GIVEN, THE WELDING SHALL BE CONTINUOUS BETWEEN ABRUPT CHANGES IN DIRECTION. NO INTERMITTENT WELDS SHALL BE PERMITTED, UNLESS OTHERWISE NOTED.

MASONRY

- 1. COMBINED COMPRESSIVE STRENGTH OF THE MASONRY PRISM SHALL BE 1500 PSI AT 28 DAYS AFTER GROUTING. ALL MASONRY SHALL BE INSPECTED DURING CONSTRUCTION.
2. GROUT ALL REINFORCED CELLS OF CONCRETE BLOCK MASONRY.
3. MORTAR SHALL BE TYPE S PER ASTM C270. GROUT SHALL HAVE A MINIMUM COMPRESSIVE STRENGTH AT 28 DAYS OF 2500 PSI.
4. PROVIDE #5 DOWELS AT 48" VERTICAL ANCHORAGE AT THE BASE OF ALL MASONRY WALLS, UNLESS OTHER ANCHORAGE IS SHOWN OR SPECIFIED.

REINFORCEMENT LAP SPlice AND EMBEDMENT LENGTHS IN MASONRY
Table with columns: BAR SIZE, EMBEDMENT LENGTH, MIN LAP LENGTHS (8" AND 12" CMU SINGLY REINF, 12" CMU DOUBLY REINF)

LAP SPlice AND EMBEDMENT LENGTHS ARE BASED ON A MINIMUM MASONRY COMPRESSIVE STRENGTH OF 1500 PSI AND 60000 PSI FOR REINFORCEMENT (WITH NO EPOXY COATING).

SPECIAL INSPECTION (CON'T)

- I-3 THE DESIGNATED INSPECTING AGENCY IS RESPONSIBLE FOR ALL REQUIRED TESTING AND INSPECTION (INCLUDING SPECIAL INSPECTION). THE SPECIAL INSPECTION ENGINEERS ARE RESPONSIBLE FOR FILING AND OBTAINING APPROVAL OF ALL STATEMENTS, TEST AND INSPECTION REPORTS, INCLUDING STEEL AND CONCRETE PRODUCER'S CERTIFICATES.
I-4 CONTRACTOR TO NOTIFY THE SPECIAL INSPECTION ENGINEERS AT LEAST 48 HOURS PRIOR TO START OF WORK.

ABBREVIATIONS

Table of abbreviations including: AB ADD'L, AL ALUMINUM, ALT ALTERNATE, APPROX APPROXIMATE, ARCH ARCHITECTURAL, BAL BALANCE, BET BETWEEN, BEV BEVELED, BL BUILDING LINE, BLDG BUILDING, BLK BLOCK, BM BEAM, BOT BOTTOM, BRG BEARING, C CHANNEL STRUCTURAL SHAPE, CANT'L CANTILEVER, CJ CONSTRUCTION JOINT, CL CENTERLINE, CLEAR CLEAR, CMU CONCRETE MASONRY UNIT, COL COLUMN, COMP COMPRESSIBLE, CONC CONCRETE, CONN CONNECTION, CONST CONSTRUCTION, CONT CONTINUOUS, CSTG CASTING, C/C CENTER TO CENTER, CTR CENTER, DET DETAIL, DIA, d DIAMETER, DIAG DIAGONAL, DIM DIMENSION, DL DEAD LOAD, DN DOWN, DO DITTO, DP DEEP, DWG DRAWING, DWL DOWEL, E EAST, EA EACH, EF EACH FACE, EJ EXPANSION JOINT, EL ELEVATION, ELEC ELECTRICAL, EMB EMBEDMENT, ENCL ENCLOSURE, EQ EQUAL, EQUIP EQUIPMENT, ES EACH SIDE, EW EACH WAY, EW T&B EACH WAY TOP & BOTTOM, EXIST EXISTING, EXP EXPANSION, EXT EXTERIOR, FB FLOOR BEAM, FCO FLOOR CLEAN OUT, FD FLOOR DRAIN, FDN FOUNDATION, FF FAR FACE, FIN FINISH, FL FLOOR, FTG FOOTING, GA GAUGE, GALV GALVANIZE, GB GRADE BEAM, GD GRADE, GRTG GRATING, H HIGH, HT HEIGHT, HORZ HORIZONTAL, HPT HIGH POINT, HS HIGH STRENGTH, HVAC HEATING, VENTILATING & AIR CONDITIONING, ID INSIDE DIAMETER, IF INSIDE FACE, INV INVERT, JT JOINT, KO KNOCK OUT, L ANGLE (STRUCTURAL SHAPE), LG LONG, LL LIVE LOAD, LLH LONG LEG HORIZ, LLV LONG LEG VERT, LOC LOCATION, LPT LOW POINT, LW LONG WAY, MAS MASONRY, MAX MAXIMUM, MECH MECHANICAL, MEZZ MEZZANINE, MFR MANUFACTURE, MANUFACTURER, MH MANHOLE, MID MIDDLE, MIN MINIMUM, N NORTH, NF NEAR FACE, # NUMBER, NTS NOT TO SCALE, OC ON CENTER, OD OUTSIDE DIAMETER, OF OUTSIDE FACE, OPNG OPENING, OPP OPPOSITE, PC PRECAST CONCRETE, PCO PILE CUT OFF, PL PLATE, PSF POUNDS PER SQUARE FOOT, PVC POLYVINYL CHLORIDE, R RADIUS, RISER, RD ROOF DRAIN, REINF REINFORCEMENT, REQD REQUIRED, RM ROOM, RO ROUGH OPENING, S SOUTH, SCH SCHEDULE, SECT SECTION, SH SHEET, SIM SIMILAR, SL SLAB, SP SPIRAL, SPEC SPECIFICATION, SQ SQUARE, SS STAINLESS STEEL, STD STANDARD, STIR STIRRUP, STL STEEL, STRUCT STRUCTURAL, SW SHORT WAY, T&B TOP AND BOTTOM, TOC TOP OF CONCRETE, THK THICK, T/ TOP OF, T TREAD, TYP TYPICAL, UON UNLESS OTHERWISE NOTED, VERT VERTICAL, WF WIDE FLANGE STRUCTURAL SHAPE, WIDTH, WEST, W/ WITH, WP WORKING POINT, WS WATERSTOP

Users: arches - Spacie - PIRNIE - STANDARD - File: I:\ACAD\PROJ\5324A073.DWG - Scale: 1:1 Date: 12/04/2009 Time: 08:02 Layout: GS-1

MALCOLM PIRNIE



REVISIONS table with columns: NO., BY, DATE, REVISIONS, REMARKS

DES TBD
DWN HBD
CHK LT

COVINA IRRIGATING COMPANY
GLEN DORA, CALIFORNIA
UV/CHLORAMINES FOR TEMPLE WTP

TEMPLE WATER TREATMENT PLANT
GENERAL NOTES AND ABBREVIATIONS
SCALE: NONE

COPYRIGHT © 2009 MALCOLM PIRNIE, INC.
DATE DECEMBER 2009
GS SHEET 1 OF 3
CAD REF. NO. 5324A073

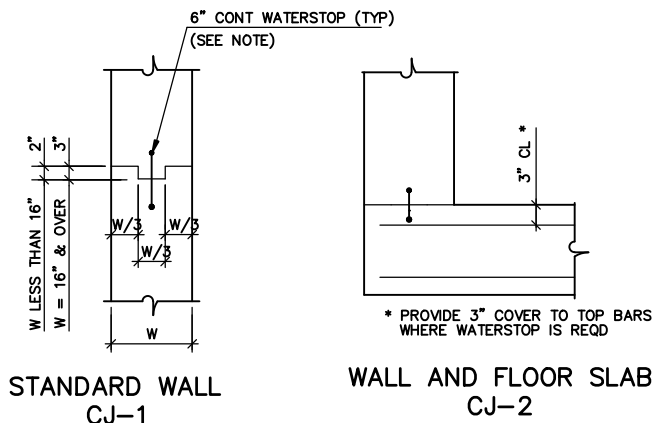

NOTE:  
OMIT KEY FOR WALLS LESS THAN 12" THICK.

CONSTRUCTION JOINTS

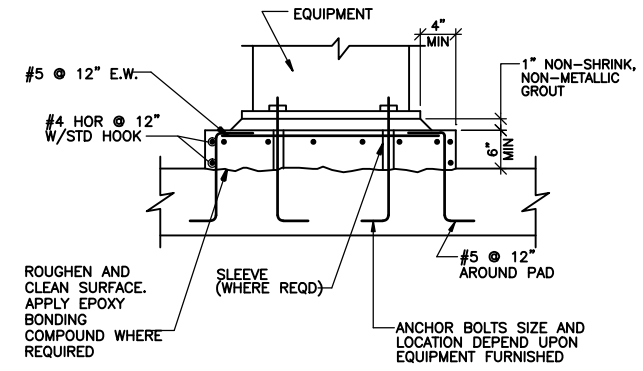

TYPICAL EQUIPMENT SUPPORT PAD DETAIL  
FOR ALL EQUIPMENT SUPPORT PADS UON

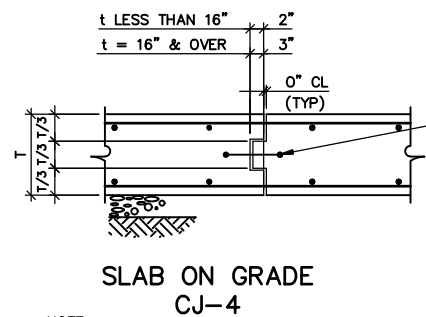

NOTE:  
1. OMIT KEY FOR SLABS LESS THAN 12" THICK.

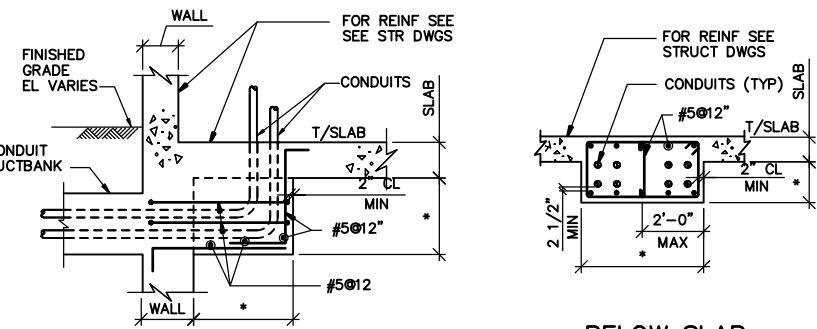

TYPICAL CONDUIT ENCASEMENT DETAIL

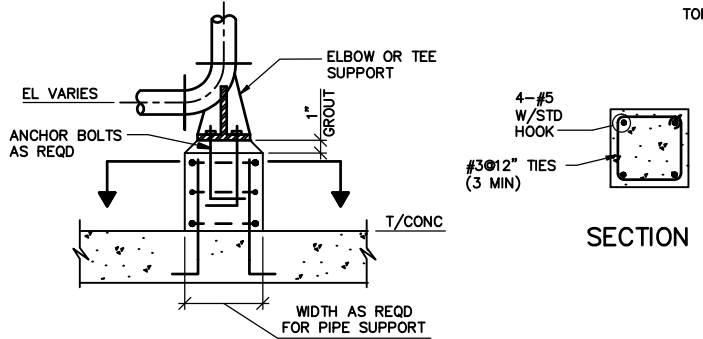

CONCRETE PEDESTAL DETAIL

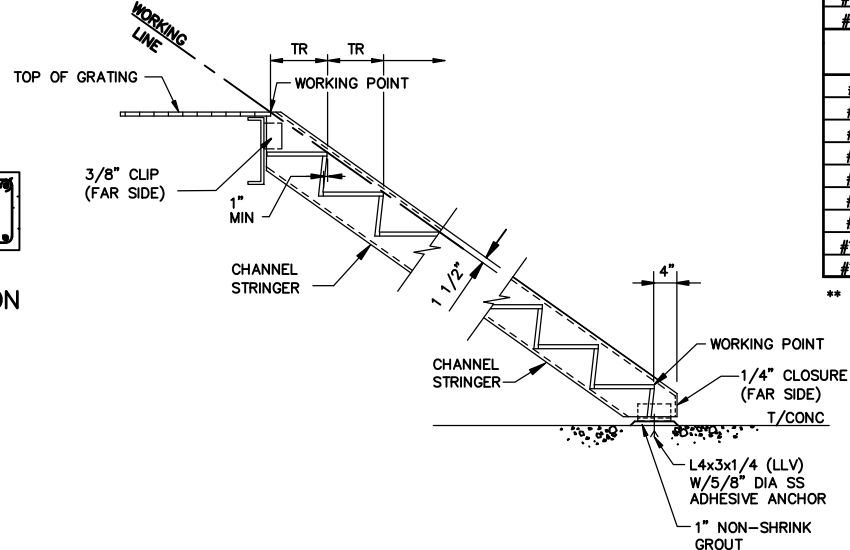

FRP STAIR DETAIL

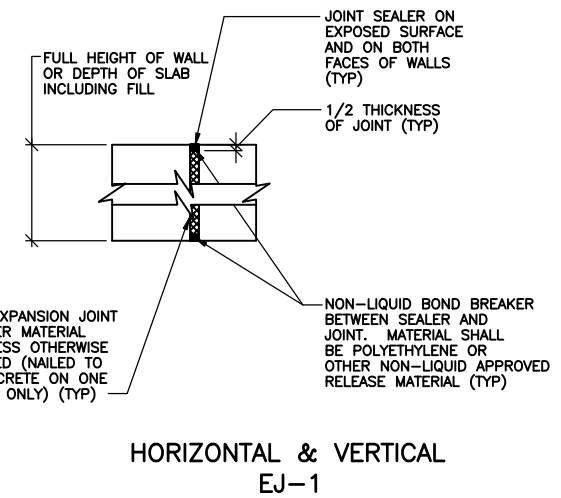

TYPICAL EXPANSION JOINT DETAIL

NOTE:  
1. PREFORMED EXPANSION JOINT FILLER SHALL COMPLY WITH ASTM D 1752, TYPE II CORK.

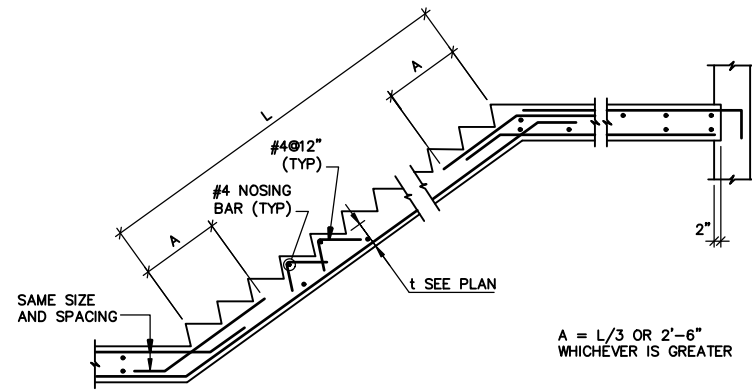

CONTINUOUS CONCRETE STAIR LANDING

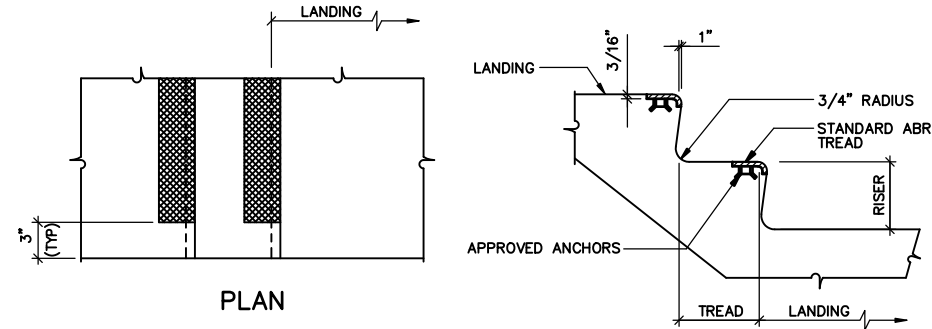

STAIR NOSING  
PLAN  
SECTION

REINFORCING LAP SPlice & EMBEDMENT LENGTH							
BAR SIZE	MIN LAP LENGTH (IN)				MIN EMBEDMENT LENGTH (IN)		
	TOP BARS		OTHER BARS		STRAIGHT BARS		WITH STD HOOK
	CLASS A	CLASS B	CLASS A	CLASS B	TOP BARS	OTHER BARS	
<b>SLABS &amp; WALLS WITH 2" + COVER</b>							
#3	16	21	12	16	16	12	6
#4	16	21	12	16	16	12	7
#5	20	25	15	19	20	15	9
#6	24	30	18	23	24	18	10
#7	33	43	25	33	33	25	12
#8	38	49	29	37	38	29	14
#9	49	63	37	48	49	37	15
#10	60	78	46	60	60	46	17
#11	75	97	57	74	75	57	19
<b>SLABS &amp; WALLS WITH &lt; 2" COVER</b>							
#3	16	21	12	16	16	12	8
#4	16	21	12	16	16	12	10
#5	20	25	15	19	20	15	12
#6	24	30	18	23	24	18	15
#7	38	49	29	37	38	29	17
#8	47	62	36	47	47	36	19
#9	58	76	44	58	58	44	22
#10	71	91	54	70	71	54	25
#11	85	110	65	84	85	65	27
<b>BEAMS &amp; COLUMNS WITH 3.75" CLEAR SPACING **</b>							
#3	16	21	12	16	16	12	6
#4	16	21	12	16	16	12	7
#5	20	25	15	19	20	15	9
#6	24	30	18	23	24	18	10
#7	33	43	25	33	33	25	12
#8	39	51	30	39	39	30	14
#9	50	64	38	49	50	38	15
#10	60	78	46	60	60	46	17
#11	72	94	55	72	72	55	19

\*\* FOR BAR CLEAR SPACING LESS THAN 3.75", ADD 46%  
FOR BAR CLEAR SPACING LESS THAN 2.25", ADD 104%

- NOTES:
- NOTES FOR SPLICE AND EMBEDMENT TABLE:
    - THE MINIMUM LENGTH OF LAPS FOR SPLICES SHALL BE AS GIVEN IN THE TABLE FOR CLASS "B" LAPS UNLESS SHOWN OTHERWISE ON THE DRAWINGS. PROVIDE CLASS "A" LAPS ONLY WHERE NOTED ON THE DRAWINGS.
    - THE SPLICE AND EMBEDMENT LENGTHS FOR WALLS AND SLABS ARE BASED ON A 5" MINIMUM ON CENTER BAR SPACING. SEE THE DRAWINGS FOR SPLICE AND EMBEDMENT WHERE BARS ARE SPACED CLOSER THAN 5". HOOK EMBEDMENTS APPLY ONLY WHERE THE SIDE COVER (NORMAL TO THE HOOK PLANE) IS AT LEAST 2.5". THE COVERS REFERENCED ON THE TABLE ARE FROM THE HOOK EXTENSION TO THE FACE OF THE CONCRETE.
    - THE TABLE DOES NOT APPLY TO LIGHTWEIGHT CONCRETE OR EPOXY COATED REINFORCING BARS. SEE ACI 318 FOR APPROPRIATE ADDITIONAL MULTIPLIERS FOR THOSE CASES.
  - WHERE SPLICES ARE REQUIRED BETWEEN BARS OF DIFFERENT SIZES, THE LAP LENGTH SHALL BE NO LESS THAN THE EMBEDMENT LENGTH OF THE LARGER BAR OR THE LAP LENGTH OF THE SMALLER BAR, WHICHEVER IS GREATER.
  - VERTICAL REINFORCEMENT FOR CONCRETE SHALL BE SPLICED WITH DOWEL BARS OF THE SAME SIZE AND SPACING FROM THE FOUNDATION USING A STANDARD SPLICE LENGTH.
  - DOWELS SHOWN EXTENDING FROM PREVIOUSLY PLACED CONCRETE SHALL EXTEND ONE SPLICE LENGTH BEYOND THE JOINT, UNLESS DIMENSIONED OTHERWISE. WHERE A DIMENSION IS PROVIDED, THE BAR SPLICING TO THE DOWEL SHALL END ONE SPLICE LENGTH FROM THE END OF THE DOWEL.

User:arfon Spec:PIRNF STANDARD File:1:\ACAD\PROJ\5324A074.DWG Scale: 1:1 Date: 12/03/2009 Time: 16:00 Layout: CS-2



REVISIONS		NO.	BY	DATE	REMARKS
DES	TBD				
DWN	HBD				
CKD	LT				

COVINA IRRIGATING COMPANY  
GLENORA, CALIFORNIA  
**UV/CHLORAMINES FOR TEMPLE WTP**

TEMPLE WATER TREATMENT PLANT  
**STRUCTURAL DETAILS 1**  
SCALE: NONE

COPYRIGHT © 2009  
MALCOLM PIRNF, INC.  
DATE: DECEMBER 2009  
GS SHEET 2 OF 3  
CAD REF. NO. 5324A074

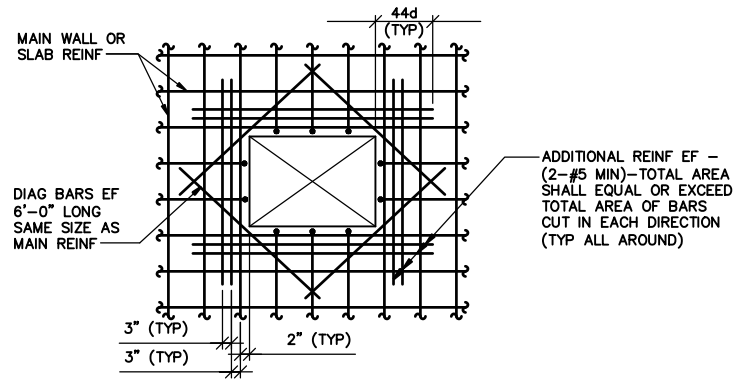

NOTE: PROVIDE STD HOOK AT END OF ALL BARS TERMINATING AT OPNG.  
**RECTANGULAR (8" SQ OR LARGER)**

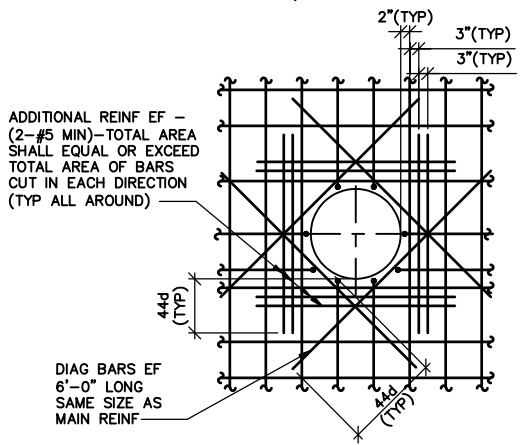

NOTE: PROVIDE STD HOOK AT END OF ALL BARS TERMINATING AT OPNG.  
**CIRCULAR (8" DIA OR LARGER)**  
**REINF AT OPENINGS IN WALLS AND SLABS**

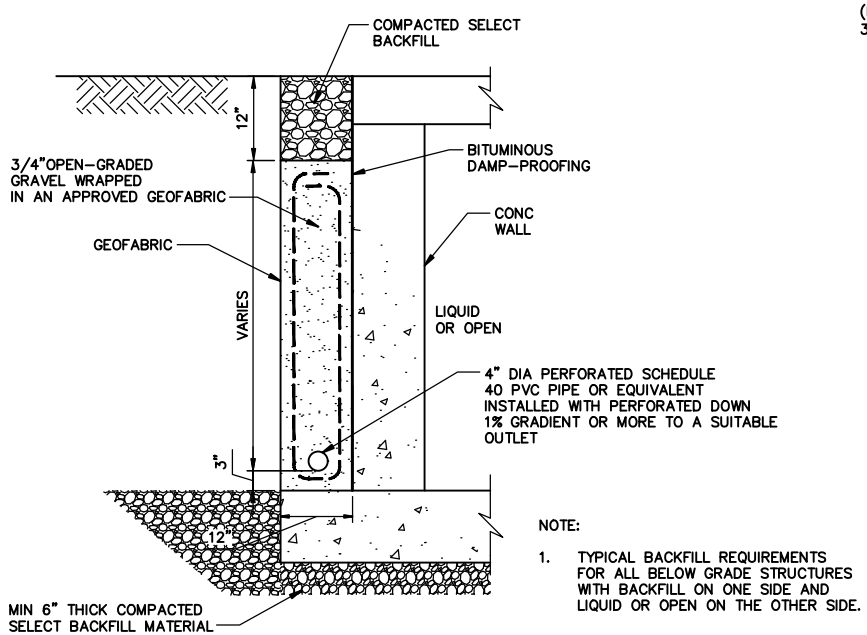

**TYPICAL CONCRETE WALL BACKFILL DETAIL**

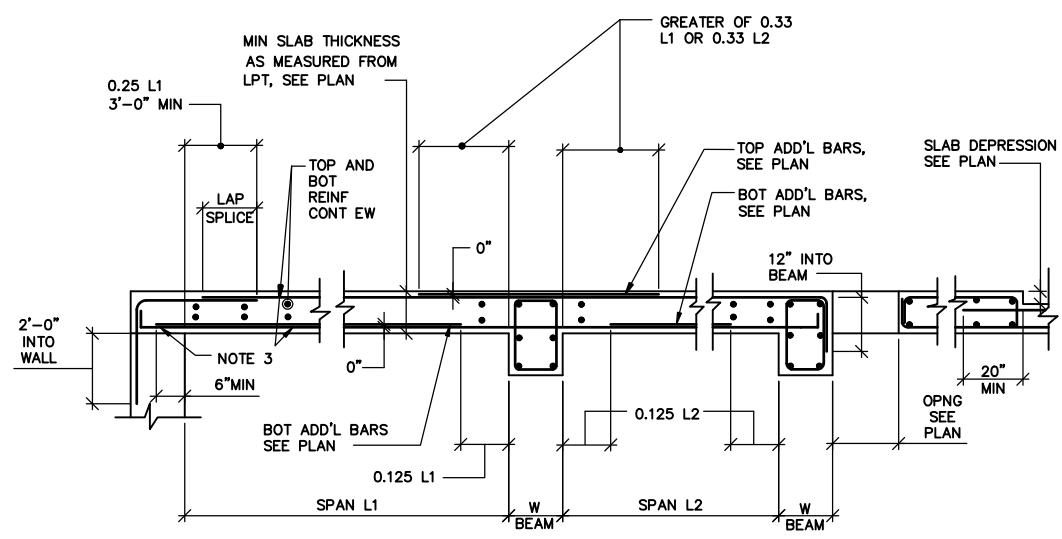

NOTES:  
 1. TOP BARS SPLICE AT MID-SPAN.  
 2. BOTTOM BARS SPLICE AT SUPPORTS.  
 3. HOOK BOTTOM CONTINUOUS BARS. IF STD HOOK DOES NOT FIT, ROTATE HOOK TO FIT AND/OR USE 180° HOOK.

**TYPICAL CONCRETE SLAB DETAIL**

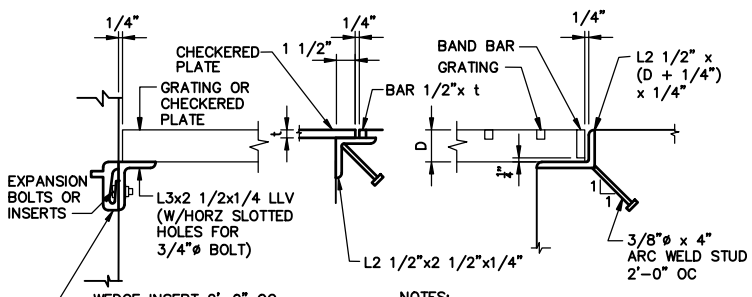

NOTES:  
 1. ALL NOTES AND DIMENSIONS ARE TYPICAL FOR SIMILAR CONDITIONS.  
 2. CONTRACTOR MAY USE SUPPORT FRAMES PROVIDED BY GRATING MANUFACTURER.  
 3. WHERE FRP GRATING IS REQUIRED USE SIMILAR DETAILS AS SHOWN & SEE SPECIFICATION.

**TYPICAL GRATING SUPPORT DETAILS**  
 NOT TO SCALE

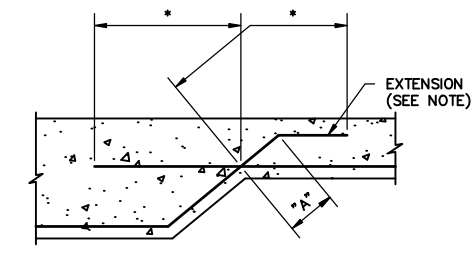

\* EMBEDMENT LENGTH, SEE SPLICE TABLE  
 NOTE:  
 EXTENSION SHOWN IS REQUIRED (12" MIN) WHEN DIAGONAL LENGTH "A" IS LESS THAN EMBEDMENT LENGTH SHOWN IN SPLICE TABLE.  
**SPLICE LENGTH OF REINFORCEMENT INTERSECTING DIAGONALLY**

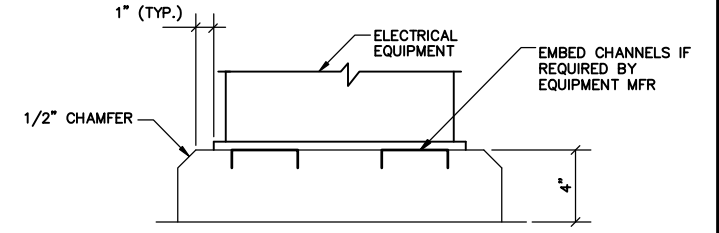

**ELECTRICAL EQUIPMENT PAD DETAIL**  
 NOTES:  
 1. COORDINATE DIMENSIONS, BOXOUTS AND CONDUIT PENETRATIONS, WITH EQUIPMENT ACTUALLY BEING PROVIDED.  
 2. PROVIDE SUPPORT CHANNELS PER EQUIPMENT MANUFACTURER'S RECOMMENDATIONS.  
 3. REFER TO TYPICAL EQUIPMENT SUPPORT PAD DETAIL FOR REINFORCING.

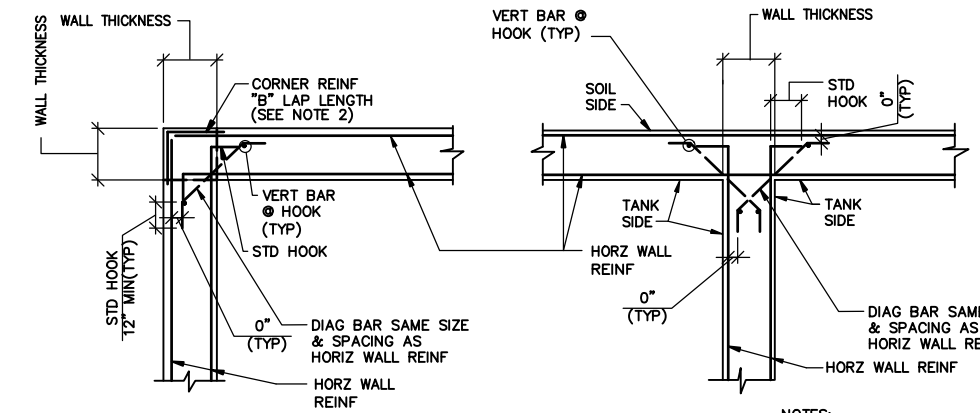

**TYPICAL REINFORCEMENT DETAIL AT WALL INTERSECTIONS**

NOTES:  
 1. PROVIDE ADDITIONAL REINF AT ALL WALL INTERSECTIONS AS SHOWN ABOVE, UON.  
 2. PROVIDE CORNER BAR REINF AT ALL WALL CORNERS AS SHOWN. CORNER BAR REINF TO MATCH SIZE AND SPACING OF WALL HORZ REINF.

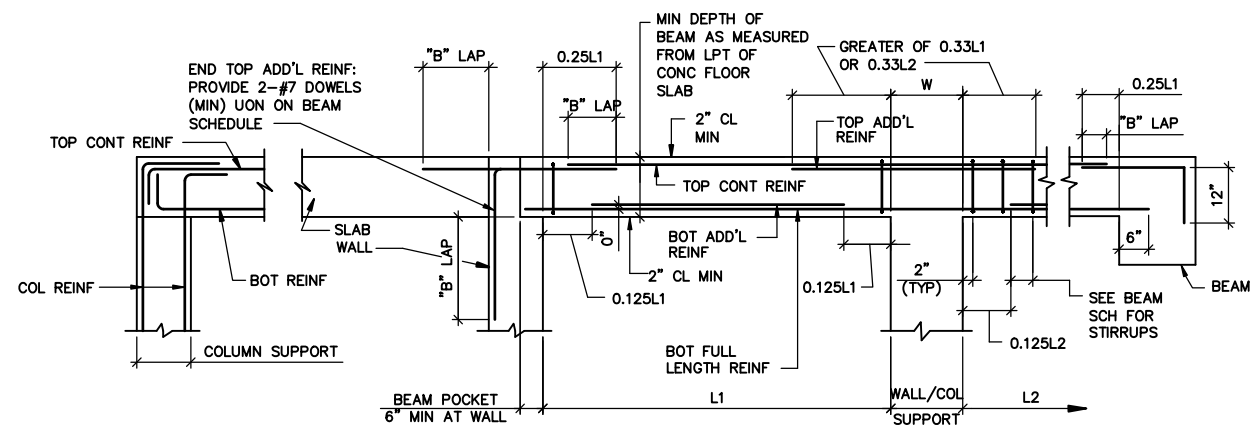

**TYPICAL REINFORCED CONCRETE BEAM DETAIL**

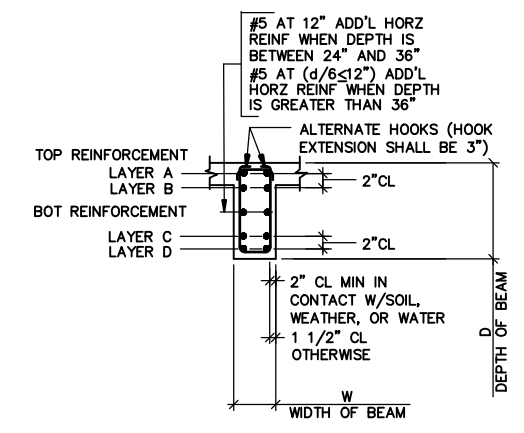

User:arfonas Spec:PIRNE STANDARD File:1:\ACAD\PROJ\5324A02 Covina\STRUCT\5324A075.DWG Scale: 1:1 Date: 12/03/2009 Time: 16:04 Layout: CS-3



REVISIONS		NO.	BY	DATE	REMARKS
DES	TBD				
DWN	HBD				
CHK	LT				

COVINA IRRIGATING COMPANY  
 GLENDORA, CALIFORNIA  
**UV/CHLORAMINES FOR TEMPLE WTP**

TEMPLE WATER TREATMENT PLANT  
**STRUCTURAL DETAILS 2**  
 SCALE: NONE

COPYRIGHT © 2009  
 MALCOLM PIRNIE, INC.  
 DATE: DECEMBER 2009  
 GS SHEET 3 OF 3  
 CAD REF. NO. 5324A075

User:Strahota Spec:PIRNF File: \\CAD\PROJ\5324A02 Covina\STRUCT\5324A076.DWG Scale:1:1 Date:06/29/2009 Time:08:19 Layout:S-1

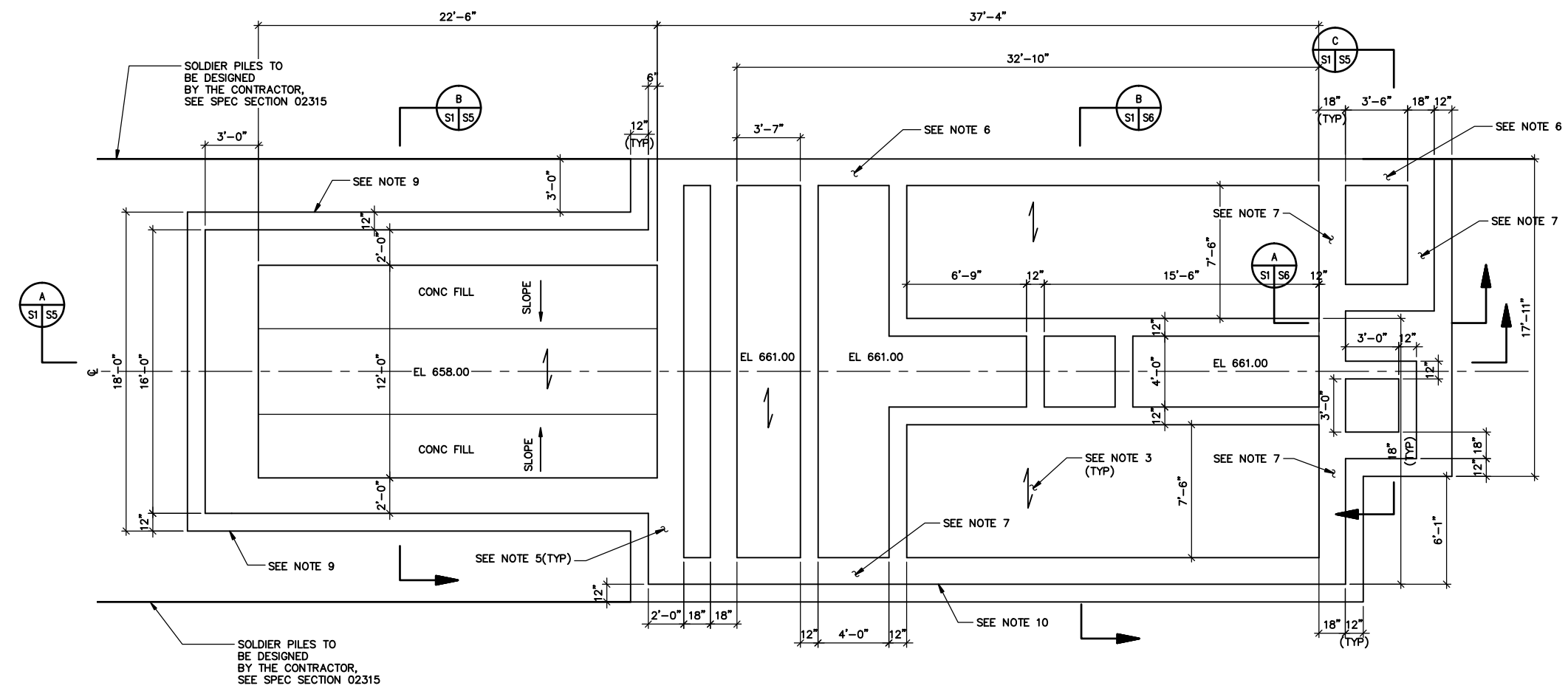

**NOTES:**

1. T/2'-6" THICK SLAB EL 658.00 UON.  
SLAB REINF: #8@6" T&B N-S DIRECTION  
#7@6" T&B E-W DIRECTION.
2. T/2'-0" THICK SLAB EL 661.00 UON.  
SLAB REINF: #7@6" T&B N-S DIRECTION  
#6@6" T&B E-W DIRECTION.
3. ——— INDICATES SPAN DIRECTION OF TOP MOST AND BOT MOST REINF.
4. FOR 12" WALL REINF DETAIL SEE TYPICAL 12" WALL REINF, SECTION A, SHEET S-5.
5. FOR 2'-0" THICK WALL REINF SEE SECTION B, SHEET S-5.
6. FOR WALL REINF SEE TYPICAL 18" N-WALL REINF, SECTION B, SHEET S-6 UON.
7. FOR WALL REINF SEE TYPICAL 18" S-WALL REINF, SECTION B, SHEET S-6
8. NET ALLOWABLE SOIL BEARING PRESSURE = 5000 PSF.
9. EITHER EXTEND MAT TO BE CAST AGAINST EXCAVATION SUPPORT OR PROVIDE WALES AT EXCAVATION SUPPORT AND STRUTS TO THE MAT EDGE.
10. THE WALL CAN BE CAST AGAINST THE EXCAVATION SUPPORT AT THE CONTRACTOR'S OPTION.

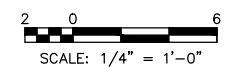

**MALCOLM PIRNIE**



REVISIONS				REMARKS
NO.	BY	DATE		

DES TBD  
DWN HBD  
CHK LT

COVINA IRRIGATING COMPANY  
GLENORA, CALIFORNIA  
**UV/CHLORAMINES FOR TEMPLE WTP**

TEMPLE WATER TREATMENT PLANT  
**UV FACILITY**  
**PLAN AT EL 658.00 UON**  
SCALE: 1/4"=1'-0"

COPYRIGHT © 2009  
MALCOLM PIRNIE, INC.  
DATE DECEMBER 2009  
S SHEET 1 OF 9  
CAD REF. NO. 5324A076



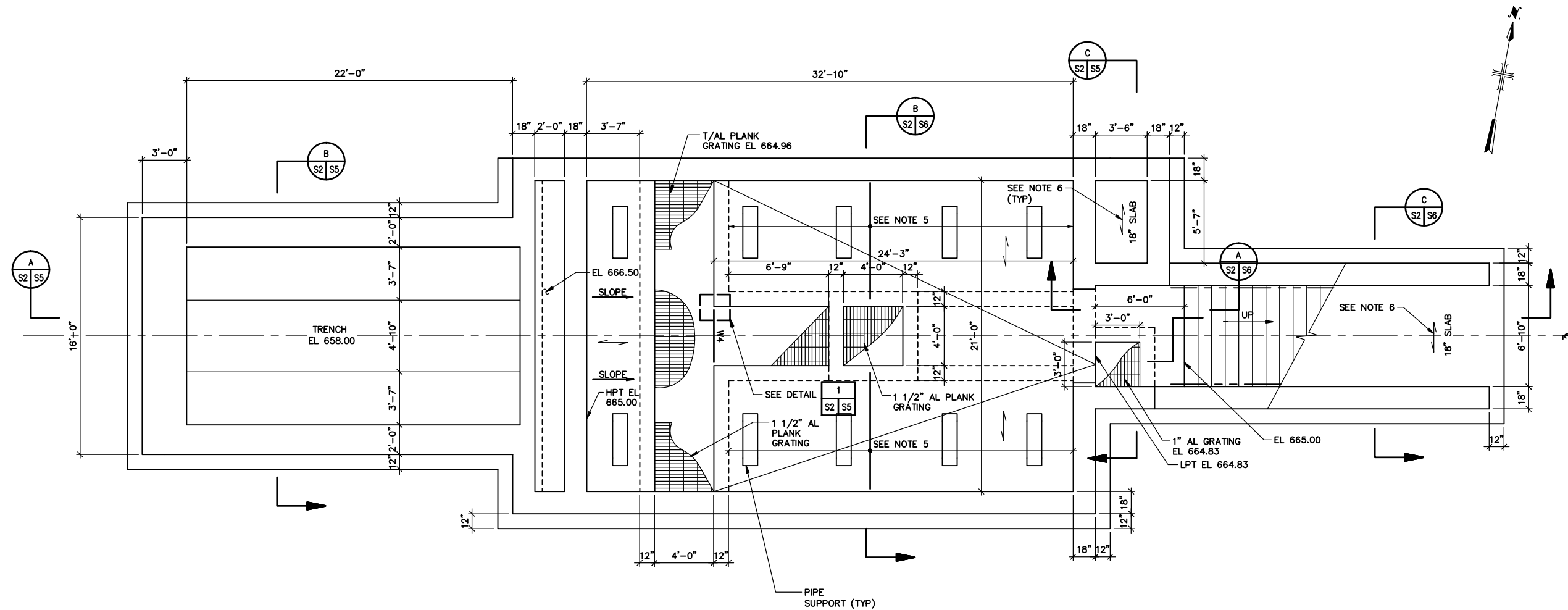

NOTES:

1. DESIGN LL = 100 PSF.
2. W4 = W4x13 (GALVANIZED), FOR W4 TO CONCRETE SURFACE CONNECTION, SEE DETAIL 1, SHEET S-5.
3. T/12" SLAB EL 665.00 @ HPT UON  
SLAB REINF: #5@12" TOP & BOT EW. FOR ADD'L REINF SEE PLAN.
4.  $\rightarrow$  INDICATES SPAN DIRECTION OF TOP MOST AND BOT MOST REINFORCEMENT.
5. #5@12" ADD'L T&B ALTERNATE WITH SLAB REINF.
6. T/18" SLAB EL 665.00.  
SLAB REINF: #5@6" T&B EW.
7. FOR PIPE SUPPORT LOCATION AND DETAIL SEE M-SHEETS.
8. FOR OPENING IN WALL AND SLAB SEE OTHER DESCIPLINES DRAWINGS.
9. A. SEISMIC FORCE RESISTING SYSTEM: SPECIAL REINFORCED CONCRETE SHEAR WALLS.  
B. RESPONSE MODIFICATION COEFFICIENT R = 6  
C. SEISMIC RESPONSE COEFFICIENT  $C_s = 0.2856$   
D. DESIGN BASE SHEAR = 0.2856W

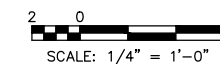

REVISIONS		NO.	BY	DATE	REMARKS

DES TBD  
DWN HBD  
CKD LT

COVINA IRRIGATING COMPANY  
GLEN DORA, CALIFORNIA  
**UV/CHLORAMINES FOR TEMPLE WTP**

TEMPLE WATER TREATMENT PLANT  
**UV FACILITY**  
**PLAN AT EL 665.00 UON**  
SCALE: 1/4"=1'-0"

COPYRIGHT © 2009  
MALCOLM PIRNIE, INC.  
DATE DECEMBER 2009  
S SHEET 2 OF 9  
CAD REF. NO. 5324A077



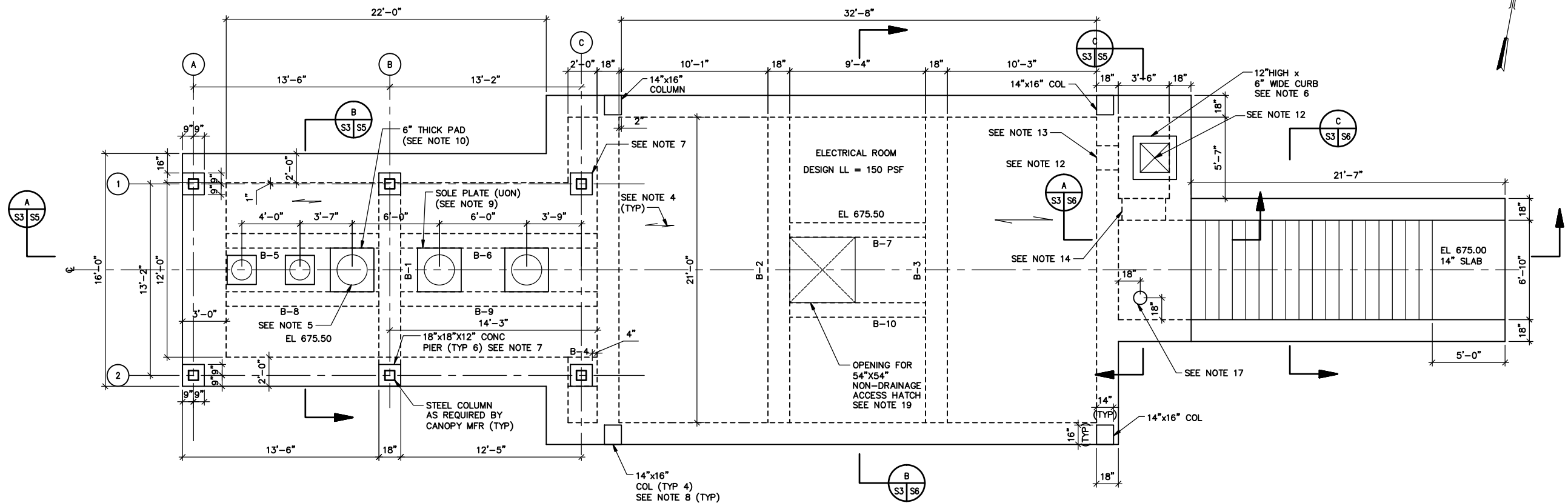

**NOTES:**

- DESIGN LL = 300 PSF UON.
- STAIR DESIGN LL = 100 PSF.
- T/12" SLAB IS EL 675.50. SLAB REINF: #6@12" TOP & BOT EW. FOR ADD'L REINF SEE PLAN.
- INDICATES SPAN DIRECTION OF TOP MOST AND BOT MOST REINFORCEMENT.
- OPENINGS FOR PUMPS SHALL BE COORDINATED WITH EQUIPMENT SUPPLIED. CONTRACTOR SHALL DETERMINE MINIMUM OPENING SIZE WITH PUMP MANUFACTURER.
- FOR CURB DETAIL, SEE SHEET S-6.
- FOR 18"x18" CONC PIER DETAIL, SEE SHEET S-5. THE FINAL CONC PIER DESIGN IS DEPENDENT ON HORZ AND VERT LOADS TO BE PROVIDED BY THE CANOPY MANUFACTURER. ANY DISCREPANCIES BETWEEN THESE LOADS AND ASSUMED FACTORED LOADS SHOWN BELOW THAT REQUIRE REVISION OF THE PIER DESIGN ARE TO BE MADE AT THE CONTRACTOR'S EXPENSE.  
FY (VERTICAL) = +17K  
FY (UPLIFT) = -3K  
FX (N-S,HORZ) = 3K  
FZ (E-W,HORZ) = 2.5K
- FOR 14"x16" CONC COLUMN DETAIL SEE SHEET S-6
- SIZE OF SOLE PLATE AND PUMP MOUNTING DETAIL AS REQUIRED BY THE PUMP MFR.
- SIZE OF CONC PAD INCLUDING SOLE PLATE AND PUMP MOUNTING DETAIL AS REQUIRED BY THE PUMP MFR.
- LOCATION OF B-5, B-6, B-8 & B-9 DEPEND UPON APPROVAL OF PUMP MOUNTING DETAIL.
- FOR OPNG SIZE AND DETAIL, SEE HVAC DRAWINGS.
- FOR OPNG SIZE IN WALL AND DETAIL, SEE HVAC DRAWINGS.
- FOR ACCESS HATCH OPNG IN WALL, SEE A-SHEETS.
- PLACE A PIPE SLEEVE IN BEAM B-2 & B-3 FOR 1" DIA CONDENSATE. REFER TO SHEET H-3 FOR LOCATION AND OTHER PERTAINING DETAILS.
- FOR MASONRY WALL DETAIL SEE ARCH DRAWINGS.
- -- EYEBOLT IN SLAB. FOR DETAIL SEE SHEET S-6.

- A. SEISMIC FORCE RESISTING SYSTEM: SPECIAL REINFORCED MASONRY SHEAR WALL.
- RESPONSE MODIFICATION COEFFICIENT R = 5
- SEISMIC RESPONSE COEFFICIENT Cs = 0.3427
- DESIGN BASE SHEAR = 0.3427W
- ADJUST BEAM LOCATIONS (B-7, B-10) AS REQUIRED FOR THE ACCESS HATCH INSTALLATION. REINFORCEMENT FOR BEAMS B-2, B-3, B-7 AND B-10 SHALL NOT BE FABRICATED UNLESS THE INSTALLATION DETAIL FOR ACCESS HATCH BEEN APPROVED BY THE ENGINEER.

BEAM SCHEDULE										
MARK	SPAN DIRECTION	SIZE		REINFORCING				STIRRUPS		REMARKS
		b	D	TOP		BOTTOM		SIZE	SPACING EA END 1 @ 2" BALANCE SEE BELOW	
				N OR E ADD'L	CONT	S OR W ADD'L	FULL LENGTH			
B-1	S-N	18"	30"	-	3-#7	-	3-#9	-	#4	12"
B-2	S-N	18"	30"	-	3-#7	-	4-#10	-	#4	12"
B-3	S-N	18"	30"	-	3-#7	-	4-#10	-	#4	12"
B-4	W-E	24"	30"	-	3-#7	-	3-#7	-	#4	12"
B-5	W-E	18"	30"	-	3-#7	-	3-#7	-	#4	12"
B-6	W-E	18"	30"	-	3-#7	-	3-#7	-	#4	12"
B-7	W-E	12"	18"	-	2-#6	-	2-#6	-	#4	8"
B-8	W-E	18"	30"	-	3-#7	-	3-#7	-	#4	12"
B-9	W-E	18"	30"	-	3-#7	-	3-#7	-	#4	12"
B-10	W-E	12"	18"	-	2-#6	-	2-#6	-	#4	8"

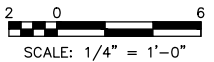

User:Strahota Spec:PIRNF STANDARD File: \\CAD\PROJ\5324A078.DWG Scale:1:1 Date:06/29/2009 Time:08:27 Layout: S-3



REVISIONS		NO.	BY	DATE	REMARKS
DES	TBD				
DWN	HBD				
CHK	LT				

COVINA IRRIGATING COMPANY  
 GLENDORA, CALIFORNIA  
**UV/CHLORAMINES FOR TEMPLE WTP**

TEMPLE WATER TREATMENT PLANT  
**UV FACILITY, PLAN AT EL 675.50 UON AND BEAM SCHEDULE**  
 SCALE: 1/4" = 1'-0"

COPYRIGHT © 2009  
 MALCOLM PIRNIE, INC.  
 DATE: DECEMBER 2009  
 S SHEET 3 OF 9  
 CAD REF. NO. 5324A078

User:Strahota Spec:PIRNF STANDARD File: \\CAD\PROJ\5324\02 Covina\STRUCT\5324A079.DWG Scale:1:1 Date:06/29/2009 Time:08:30 Layout:5-4

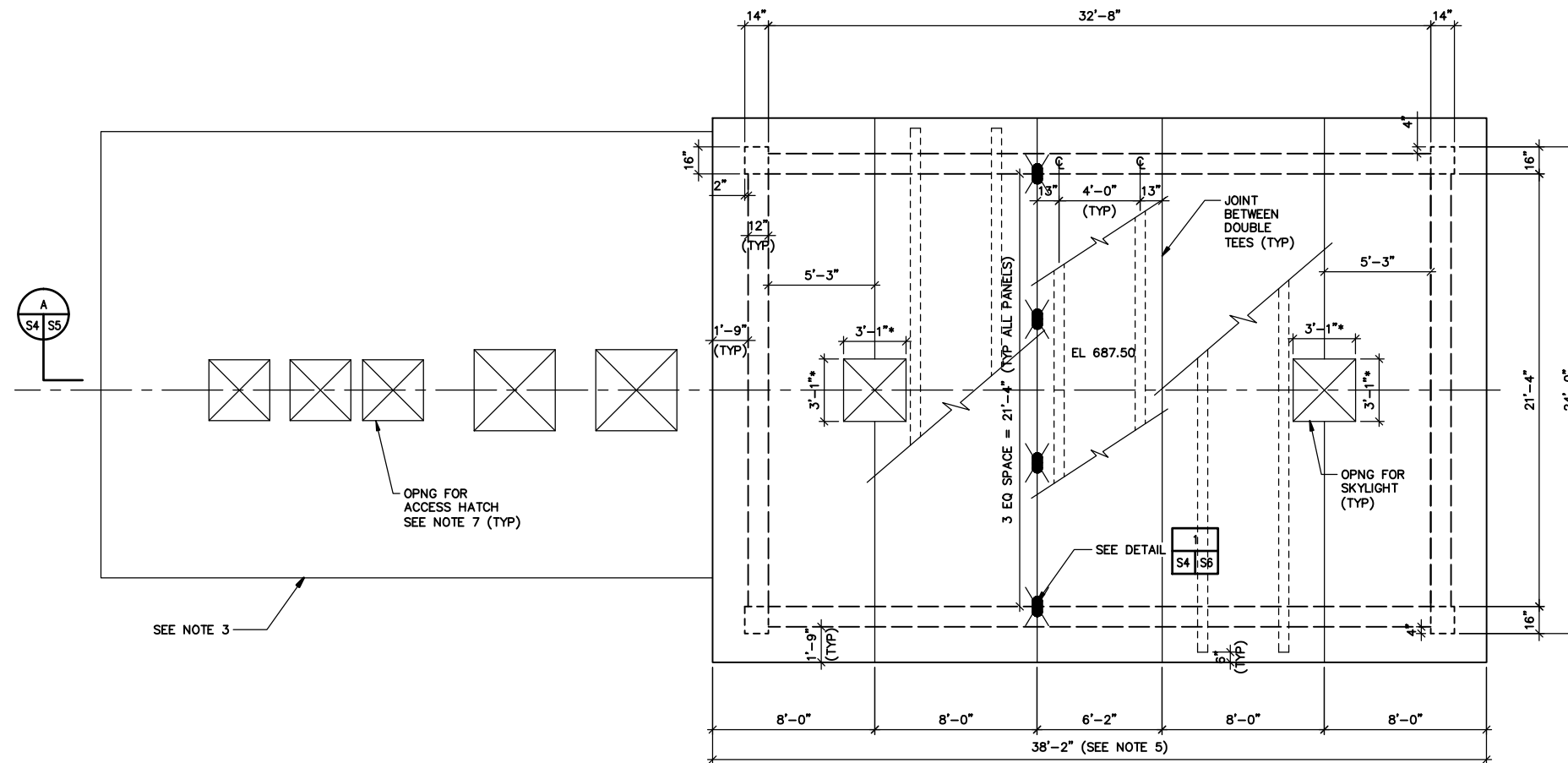

- NOTES:
- DESIGN LL = 20 PSF.
  - FOR ROOF OPNG SIZE AND DETAILS, SEE OTHER DISCIPLINES DRAWINGS.
  - FOR CANOPY ROOF SIZE AND DETAILS, SEE ARCH DRAWINGS.
  - FOR ROOF SLOPE AND OTHER PERTAINING REQUIREMENTS SEE A-SHEETS.
  - TOTAL 5 DOUBLE TEES ARE REQUIRED.
  - DOUBLE TEE SIZE = PCI 8DT20.  
ADJUST WIDTH OF THE DOUBLE TEE FLANGE AT CENTER PANEL AS SHOWN.
  - ACCESS HATCHES SHALL BE SIZED TO PROVIDE SUFFICIENT CLEAR OPENING TO REMOVE VERTICAL TURBINE PUMPS BELOW. ACTUAL DIMENSIONS OF ACCESS HATCHES SHALL BE COORDINATED WITH PUMP AND CANOPY MANUFACTURERS.
  - FOR ROOF PANEL ANCHORAGE DETAIL SEE SHEET S-6.
  - PROVIDE 2" CONCRETE TOPPING ON THE DOUBLE TEES WITH WWF 6x6 - W1.4 x W1.4

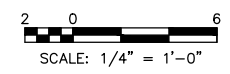

**MALCOLM PIRNIE**



REVISIONS			
NO.	BY	DATE	REMARKS

DES TBD  
DWN HBD  
CKD LT

COVINA IRRIGATING COMPANY  
GLEN DORA, CALIFORNIA  
**UV/CHLORAMINES FOR TEMPLE WTP**

TEMPLE WATER TREATMENT PLANT  
**UV FACILITY  
ROOF PLAN**  
SCALE: 1/4"=1'-0"

COPYRIGHT © 2009  
MALCOLM PIRNIE, INC.  
DATE DECEMBER 2009  
S SHEET 4 OF 9  
CAD REF. NO. 5324A079

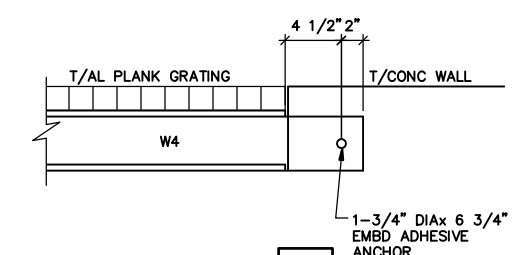
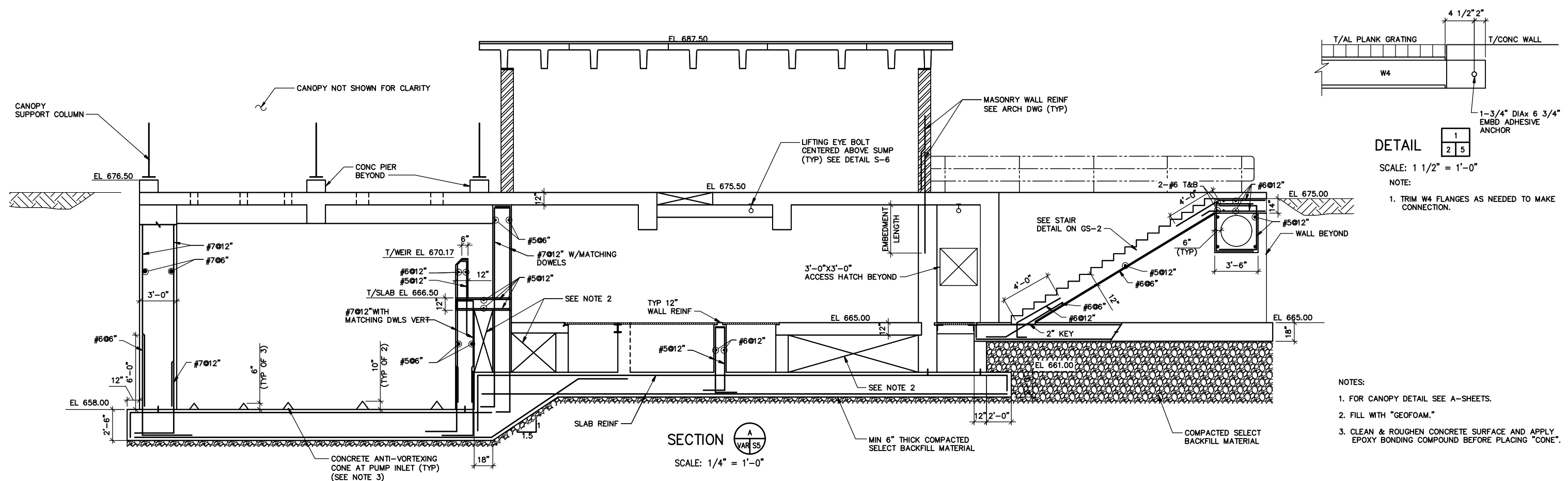

**DETAIL 1**  
 SCALE: 1 1/2" = 1'-0"  
 NOTE:  
 1. TRIM W4 FLANGES AS NEEDED TO MAKE CONNECTION.

**NOTES:**  
 1. FOR CANOPY DETAIL SEE A-SHEETS.  
 2. FILL WITH "GEOFOAM."  
 3. CLEAN & ROUGHEN CONCRETE SURFACE AND APPLY EPOXY BONDING COMPOUND BEFORE PLACING "CONE".

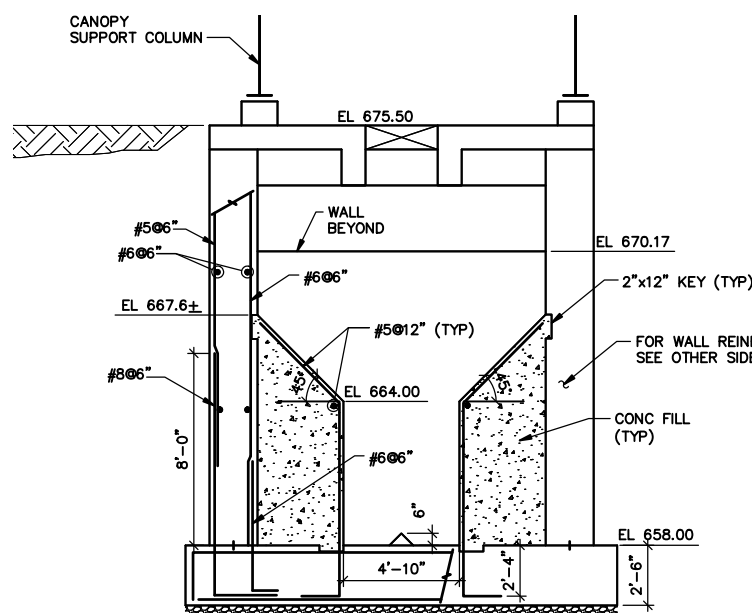

**SECTION B**  
 SCALE: 1/4" = 1'-0"

NOTE:  
 1. FOR CANOPY DETAIL SEE A-SHEETS.

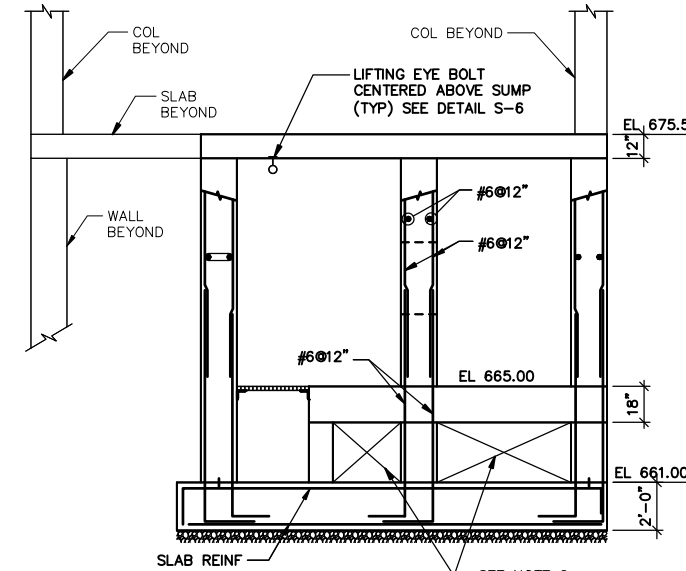

**SECTION C**  
 SCALE: 1/4" = 1'-0"

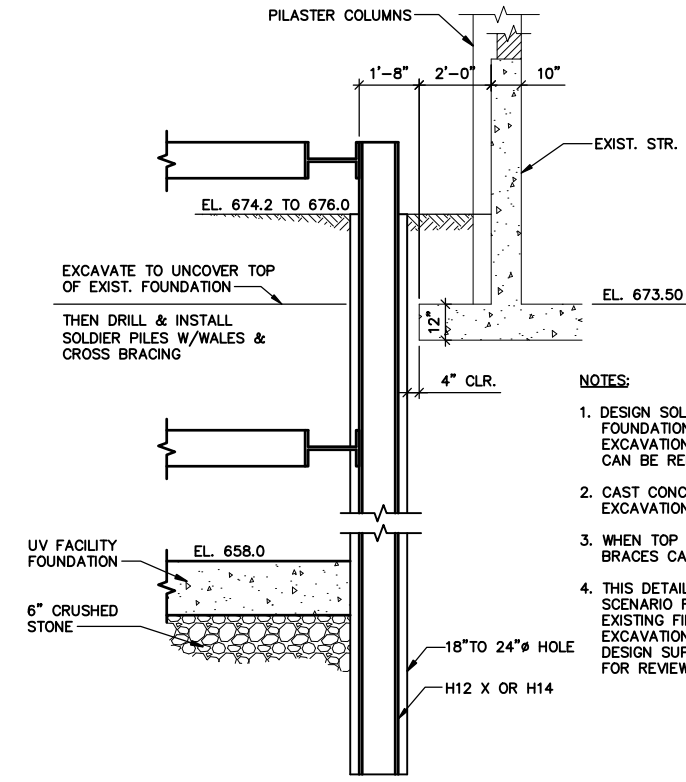

**SUGGESTED SHEETING/SHORING DETAIL**  
 SCALE: NTS

**NOTES:**  
 1. DESIGN SOLDIER PILES SO THAT WHEN FOUNDATION SLAB IS PLACED AGAINST EXCAVATION SUPPORT LOWER BRACE CAN BE REMOVED.  
 2. CAST CONCRETE WALL AGAINST EXCAVATION SUPPORT.  
 3. WHEN TOP SLAB IS CURED UPPER BRACES CAN BE REMOVED.  
 4. THIS DETAIL REPRESENTS ONE SCENARIO FOR SUPPORT OF THE EXISTING FILTER BUILDING AND EXCAVATION. CONTRACTOR SHALL DESIGN SUPPORT SYSTEM AND SUBMIT FOR REVIEW PER SPEC SECTION 02315.

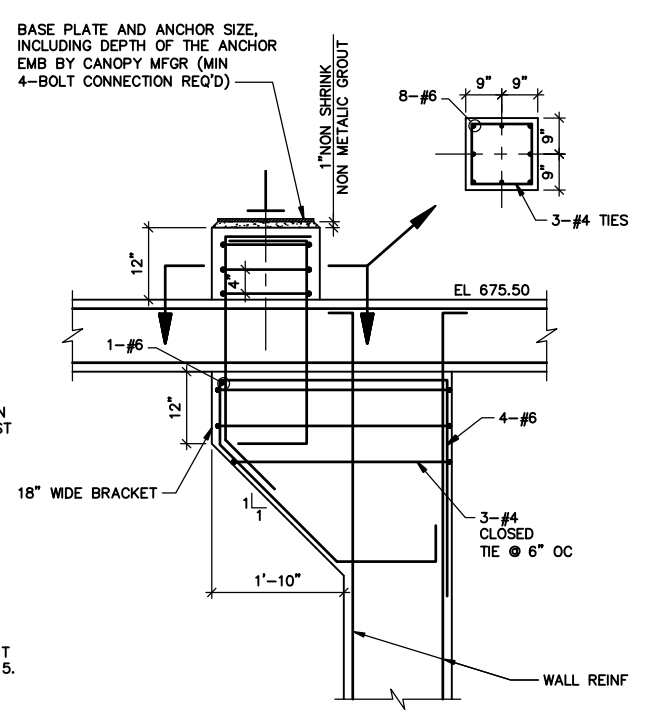

**TYPICAL 18"x18" CONC PIER DETAIL**  
 SCALE: 3/4" = 1'-0"

User:Strahota Spec:PIRNF STANDARD File: \\CAD\PROJ\5324A080.DWG Scale:1:1 Date:06/29/2009 Time:08:32 Layout: S-5



NO.	BY	DATE	REVISIONS	REMARKS

DES TBD  
 DWN HBD  
 CKD LT

COVINA IRRIGATING COMPANY  
 GLENDORA, CALIFORNIA  
**UV/CHLORAMINES FOR TEMPLE WTP**

TEMPLE WATER TREATMENT PLANT  
**UV FACILITY SECTIONS 1**  
 SCALE: AS NOTED

COPYRIGHT © 2009  
 MALCOLM PIRNIE, INC.  
 DATE DECEMBER 2009  
 S SHEET 5 OF 9  
 CAD REF. NO. 5324A080

User:Strahota Spec:PIRNF STANDARD File: \\CAD\PROJ\5324A080.DWG Scale:1:1 Date:06/29/2009 Time:08:32 Layout:5-5

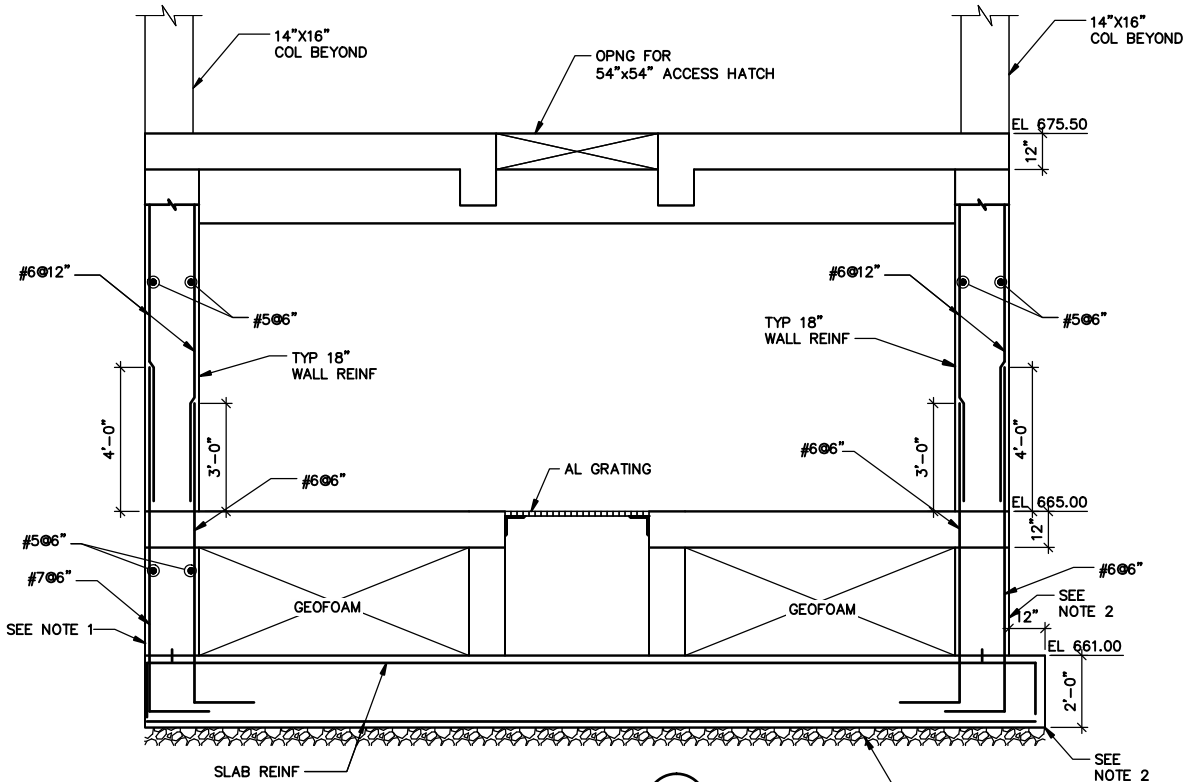
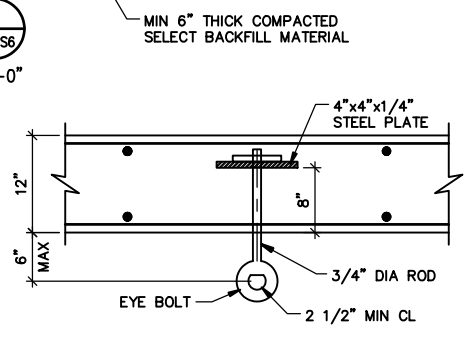
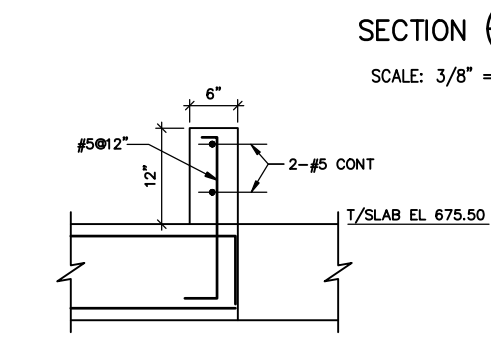
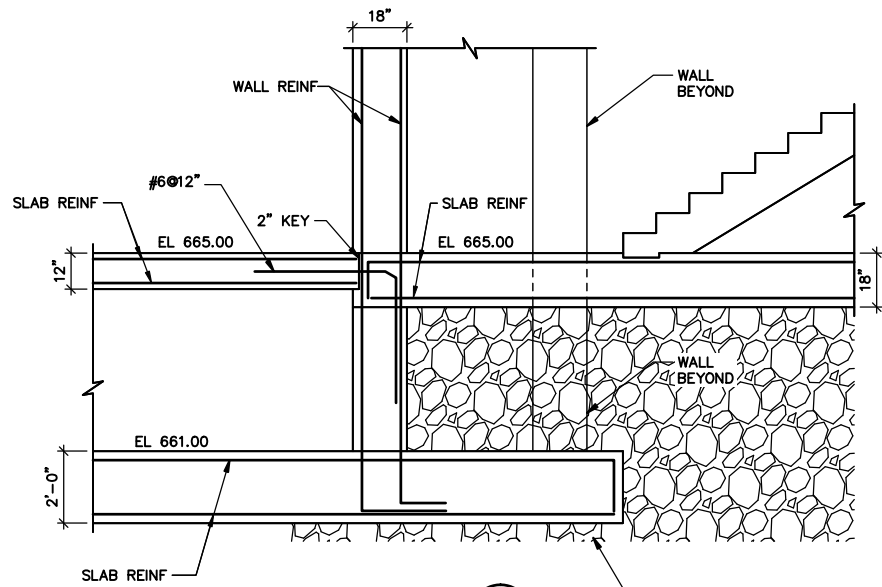

NOTE:  
1. CAST MAT AND WALL AGAINST EXCAVATION SUPPORT.  
2. SEE NOTE 9 ON SHEET S-1.

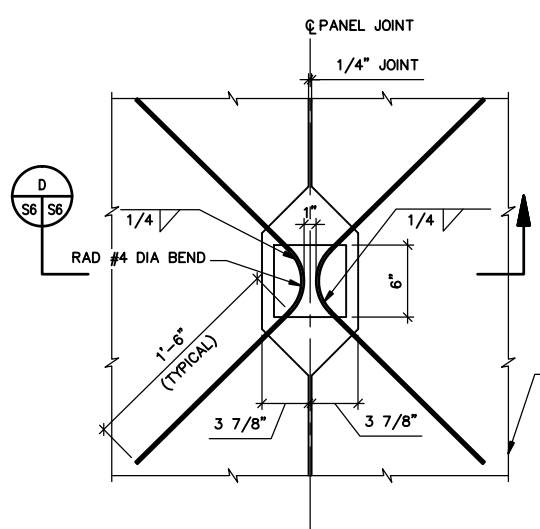
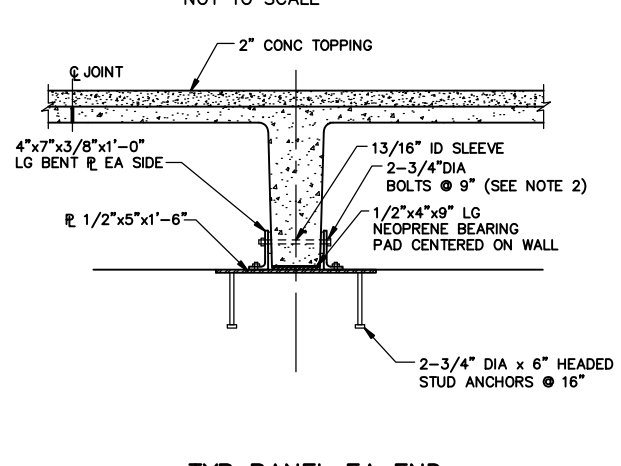
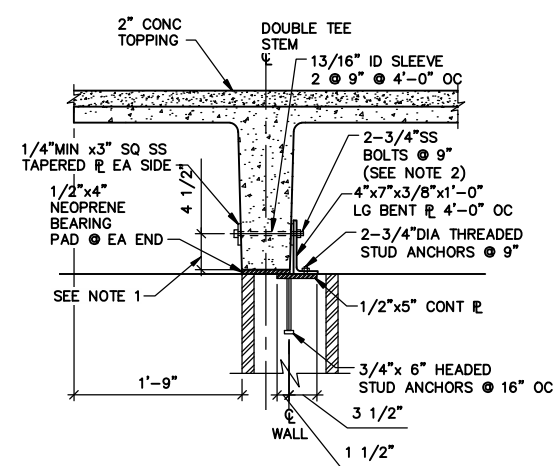
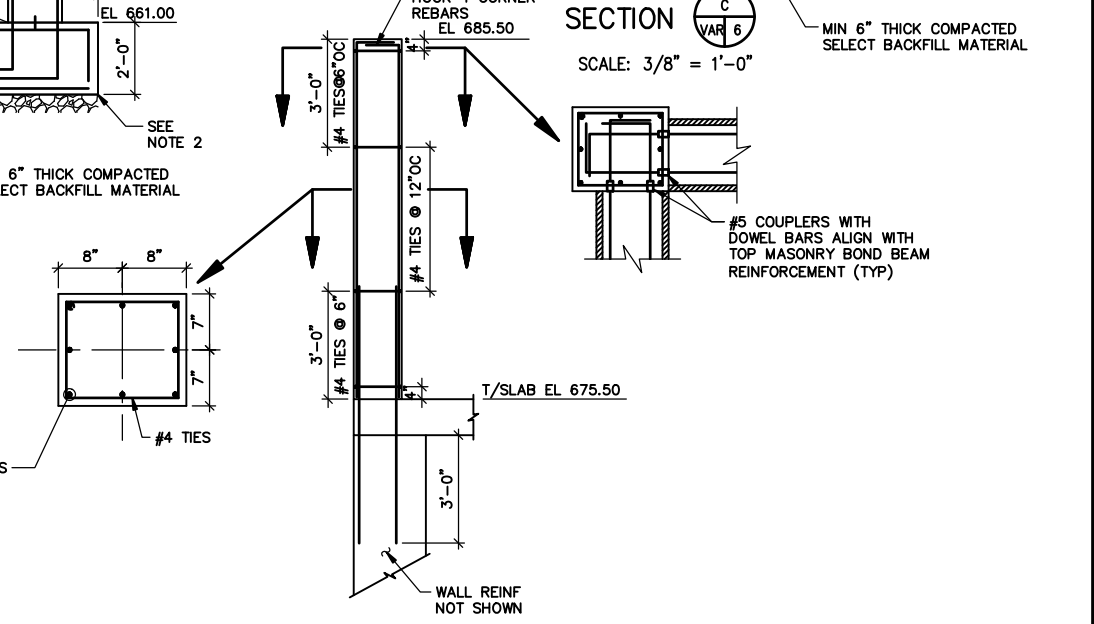
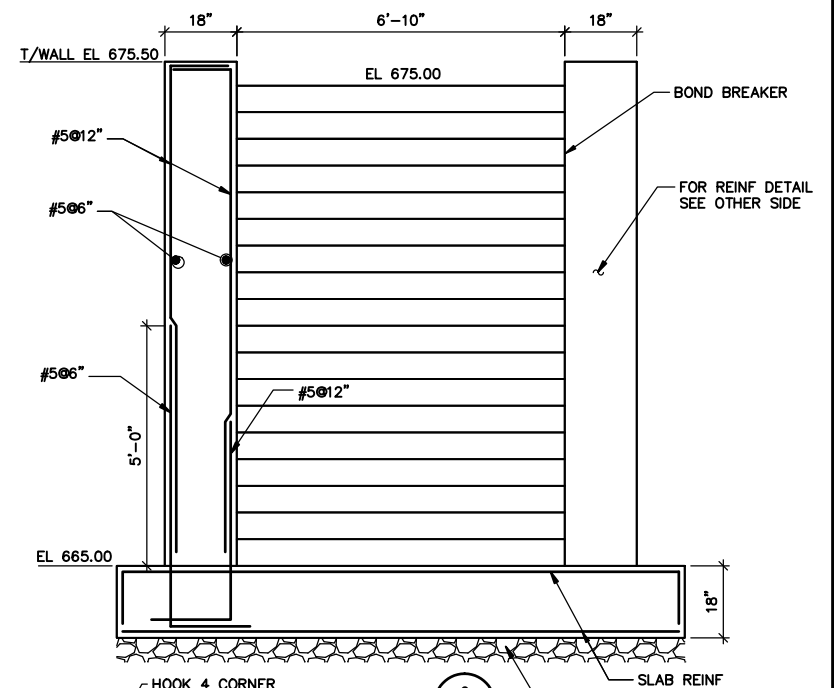

NOTES:  
1. WHERE BOLTS OR INSERTS PLACED IN PANEL RIBS INTERFERE WITH STRAND REINF, THEY SHALL BE PLACED SUCH THAT FULL CLEARANCE IS OBTAINED FOR STRANDS. THIS NOTE APPLIES TO ALL ANCHORAGE SHOWN ON THIS DRAWING.  
2. 13/16" x 1 1/2" VERT SLOTTED HOLES IN ANGLE. USE BEV. WASHER AGAINST CONCRETE.

3. DESIGN LATERAL FORCES:  
A) END PANEL:  
PARPENDICULAR TO DT STEM = 1.0K (WIND)  
PARALLEL TO DT STEM = 3K (SEISMIC)  
B) TYP PANEL AT EACH END:  
PARPENDICULAR TO DT STEM = 3K (SEISMIC)  
PARALLEL TO DT STEM = 1.0K (WIND)

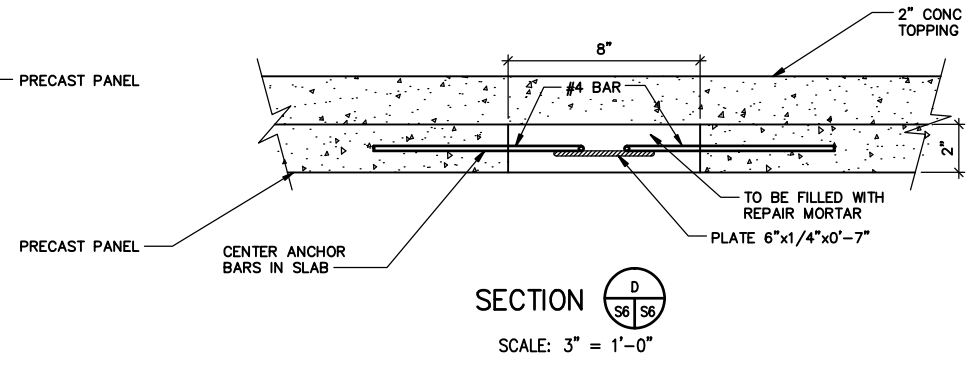

NO.	BY	DATE	REVISIONS	REMARKS

DES TBD  
DWN HBD  
CKD LT

COVINA IRRIGATING COMPANY  
GLENORA, CALIFORNIA  
**UV/CHLORAMINES FOR TEMPLE WTP**

TEMPLE WATER TREATMENT PLANT  
**UV FACILITY**  
**SECTIONS 2 AND DETAILS**  
SCALE: AS NOTED

COPYRIGHT © 2009  
MALCOLM PIRNIE, INC.  
DATE DECEMBER 2009  
S SHEET 6 OF 9  
CAD REF. NO. 5324A081

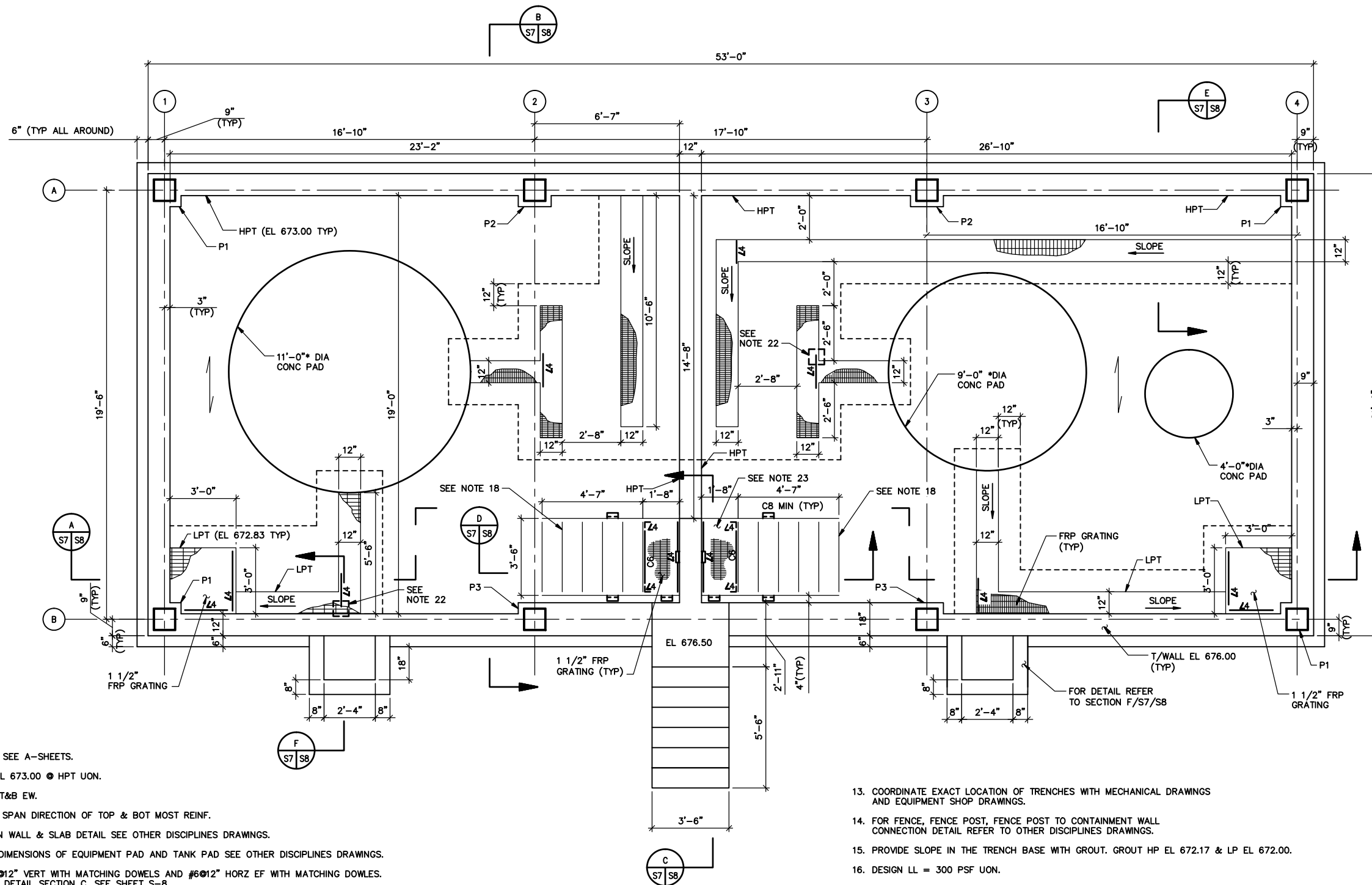

**NOTES:**

1. FOR CANOPY DETAIL SEE A-SHEETS.
2. T/24" THICK SLAB EL 673.00 @ HPT UON.  
SLAB REINF: #6@6" T&B EW.
3. ——— INDICATES SPAN DIRECTION OF TOP & BOT MOST REINF.
4. FOR PIPE OPENING IN WALL & SLAB DETAIL SEE OTHER DISCIPLINES DRAWINGS.
5. FOR LOCATION AND DIMENSIONS OF EQUIPMENT PAD AND TANK PAD SEE OTHER DISCIPLINES DRAWINGS.
6. 12" WALL REINF: #5@12" VERT WITH MATCHING DOWELS AND #6@12" HORZ EF WITH MATCHING DOWELS.  
FOR 18" WALL REINF DETAIL SECTION C, SEE SHEET S-8
7. NO ADD'L REINF REQUIRED AT WALL INTERSECTION.
8. UNIFORMLY SLOPE FLOOR FROM HIGH POINT TO LOW POINT/SUMP. LOW POINT SHALL BE EL 672.83.
9. ALL GRATING SHALL BE 1" FRP GRATING UON.
10. FOR PIER TYPE P1, P2, & P3 DETAILS SEE SHEET S-8.  
THE FINAL CONC PIER DESIGN IS DEPENDENT ON HORZ AND VERT LOADS TO BE PROVIDED BY THE CANOPY MANUFACTURER. ANY DISCREPANCIES BETWEEN THESE LOADS AND ASSUMED FACTORED LOADS SHOWN BELOW THAT REQUIRE REVISION OF THE PIER DESIGN ARE TO BE MADE AT THE CONTRACTOR'S EXPENSE.  
FY (VERTICAL) = +25K  
FY (UPLIFT) = -3K  
FX (N-S,HORZ) = 6K  
FZ (E-W,HORZ) = 5K
11. FOR CHAIN LINK FENCE DETAIL SEE OTHER DISCIPLINES DRAWINGS.
12. L4 = FRP L4x4x1/4.

13. COORDINATE EXACT LOCATION OF TRENCHES WITH MECHANICAL DRAWINGS AND EQUIPMENT SHOP DRAWINGS.
14. FOR FENCE, FENCE POST, FENCE POST TO CONTAINMENT WALL CONNECTION DETAIL REFER TO OTHER DISCIPLINES DRAWINGS.
15. PROVIDE SLOPE IN THE TRENCH BASE WITH GROUT. GROUT HP EL 672.17 & LP EL 672.00.
16. DESIGN LL = 300 PSF UON.
17. NET ALLOWABLE SOIL BEARING PRESSURE = 5000 PSF.
18. REFER TO SPECIFICATION FOR FRP STAIR DESIGN.
19. STAIR LL = 100 PSF.
20. C6 = FRP C6x1 11/16x3/8
21. C8 MIN = FRP STAIR STRINGER 8x 2 3/16 x 3/8
22. FOR FRP L4 TO CONC SURFACE CONNECTION, SEE DETAIL 1/S7/S8 SHEET S-8.
23. FRP STAIR MANUFACTURER IS RESPONSIBLE FOR DESIGN OF STAIR LANDING, INCLUDING POST, BRACING ETC.  
LANDING DETAIL SHOWN ON THE DRAWINGS IS MINIMUM REQUIREMENT.

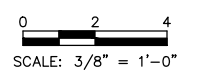

User:Stranahda Spec:PIRNFIE STANDARD File:1:\CAD\PROJ\5324A082\Covina\STRUCT\5324A081.DWG Scale:1:1 Date:04/09/2009 Time:11:43 Layout:S-6



REVISIONS		NO.	BY	DATE	REMARKS

DES TBD  
DWN HBD  
CKD LT

COVINA IRRIGATING COMPANY  
GLENORA, CALIFORNIA  
**UV/CHLORAMINES FOR TEMPLE WTP**

TEMPLE WATER TREATMENT PLANT  
**CHEMICAL FACILITY  
PLAN**  
SCALE: 3/8"=1'-0"

COPYRIGHT © 2009  
MALCOLM PIRNIE, INC.  
DATE DECEMBER 2009  
S SHEET 7 OF 9  
CAD REF. NO. 5324A082

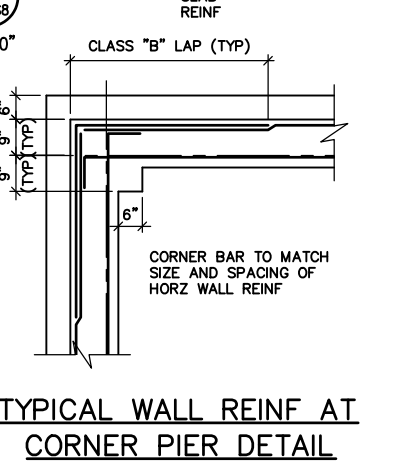
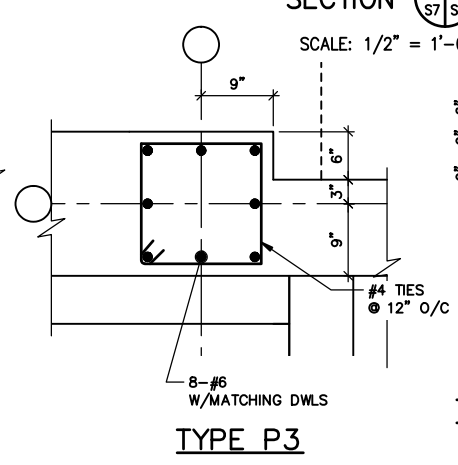
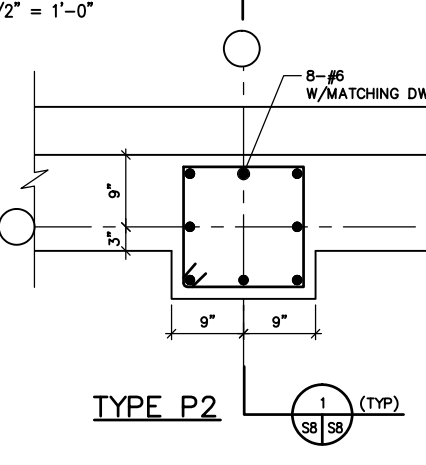
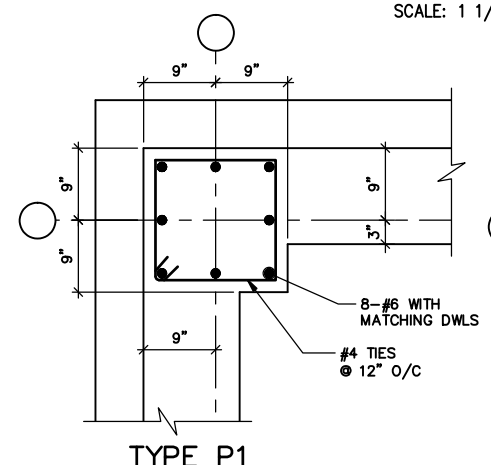
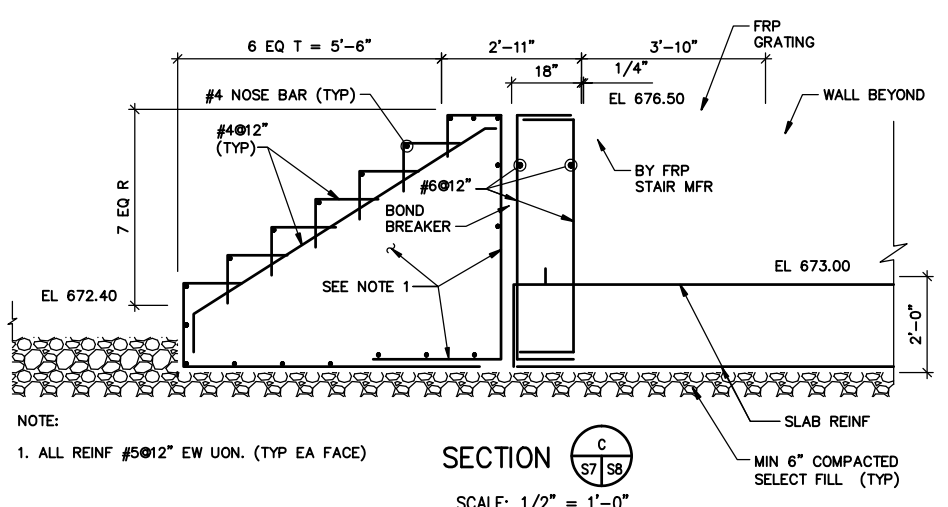
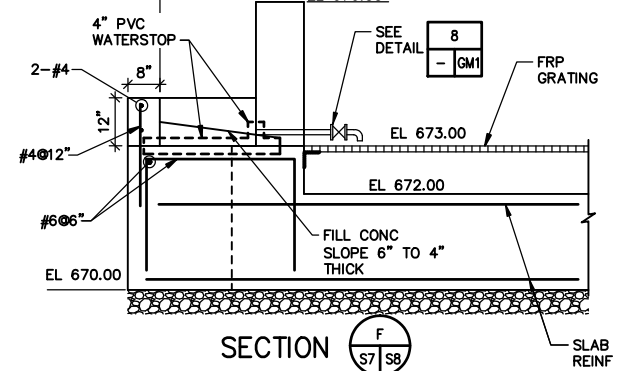
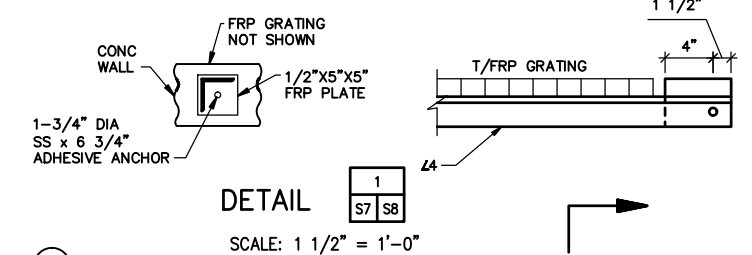
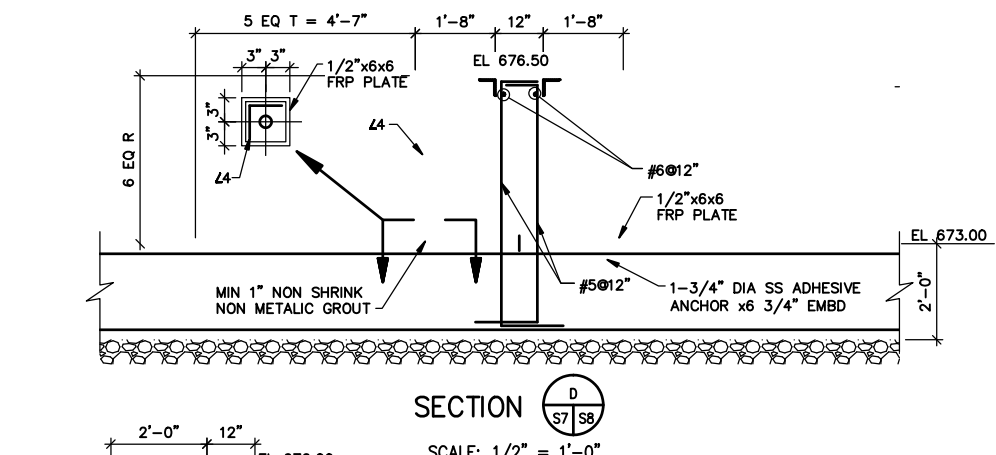
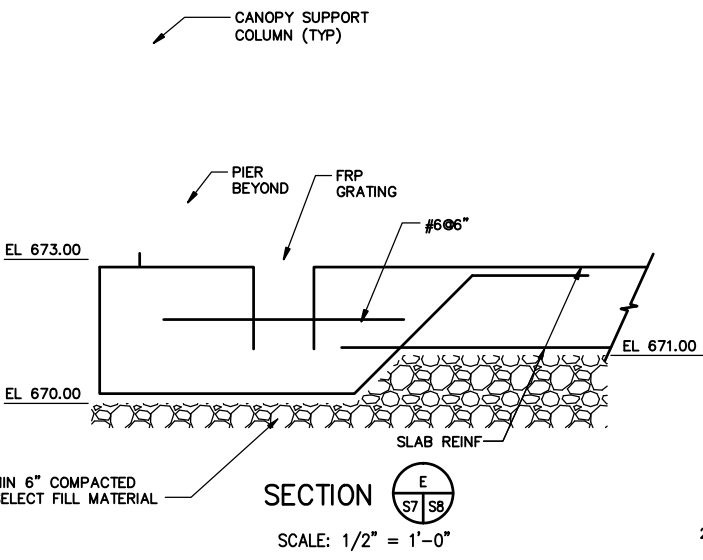
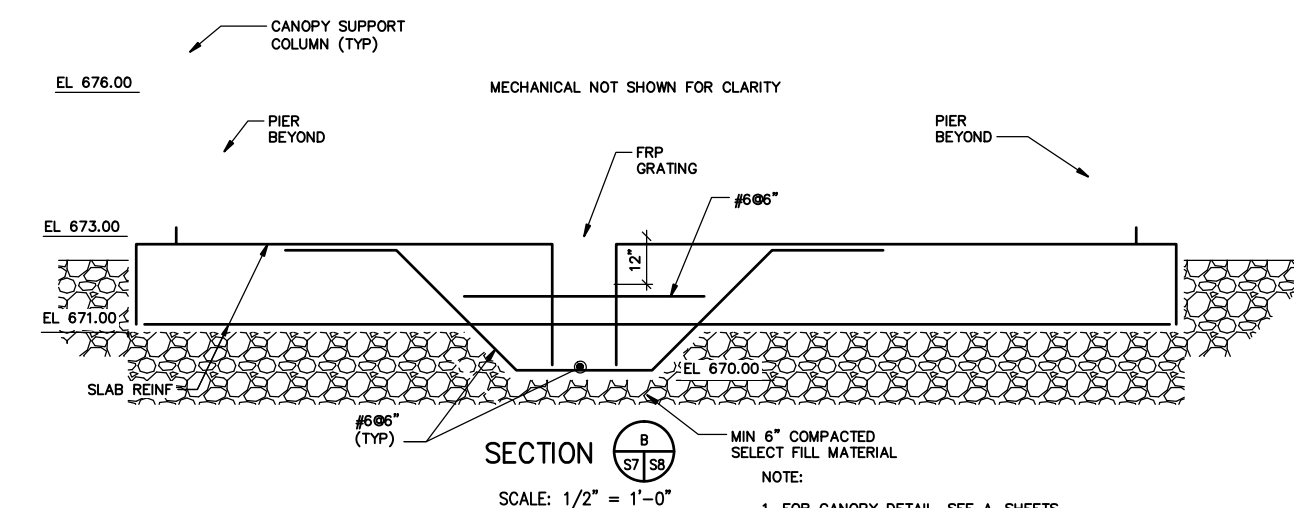
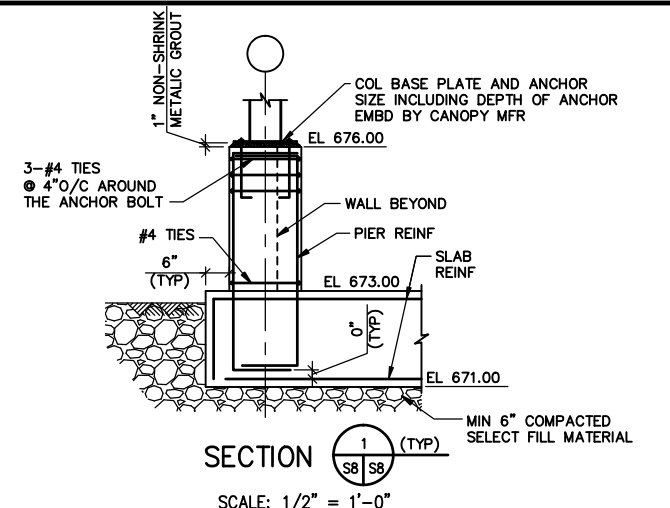
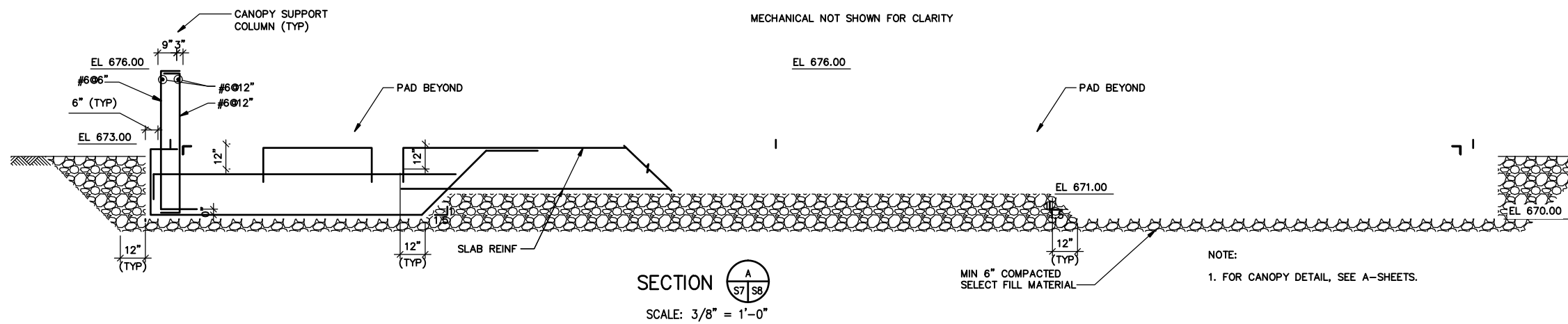

NOTE:  
1. ALL REINF #5@12" EW UON. (TYP EA FACE)

NO.	BY	DATE	REVISIONS	REMARKS

DES TBD  
DWN HBD  
CHK LT

COVINA IRRIGATING COMPANY  
GLENORA, CALIFORNIA  
**UV/CHLORAMINES FOR TEMPLE WTP**

TEMPLE WATER TREATMENT PLANT  
**CHEMICAL FACILITY**  
SECTIONS AND DETAILS  
SCALE: AS NOTED

COPYRIGHT © 2009  
MALCOLM PIRNIE, INC.  
DATE DECEMBER 2009  
SHEET 8 OF 9  
CAD REF. NO. 5324A083

User:Strahota Spec:PIRNF STANDARD File: \\CAD\PROJ\5324A083\COVINA\STRUCT\5324A081.DWG Scale:1:1 Date:04/09/2009 Time:11:43 Layout:5-6



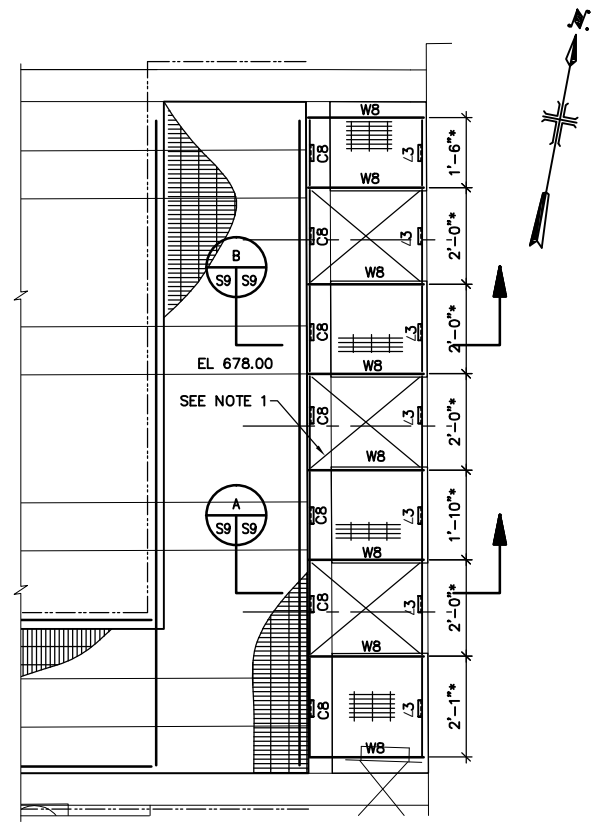

PARTIAL PLAN @ EL 678.83 UON  
SCALE: 6" = 1'-0"

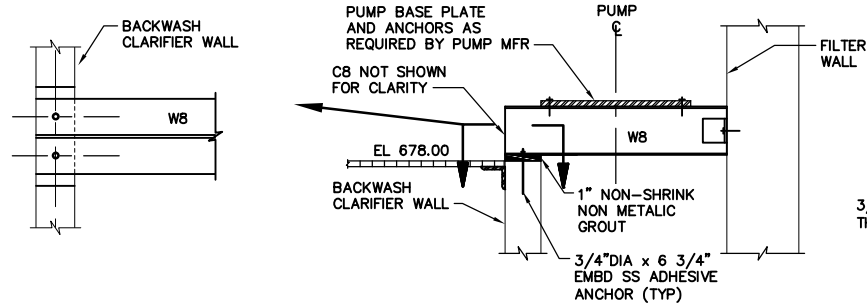

SECTION A  
S9 S9  
NOT TO SCALE

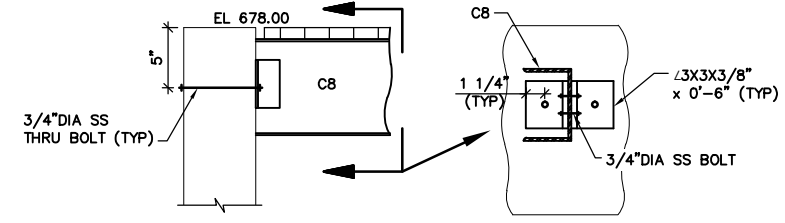

C8 TO EXISTING WALL CONNECTION DETAIL

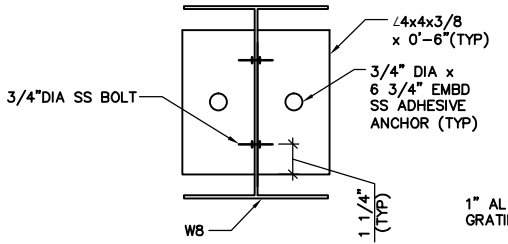

W8 TO FILTER WALL CONNECTION DETAIL

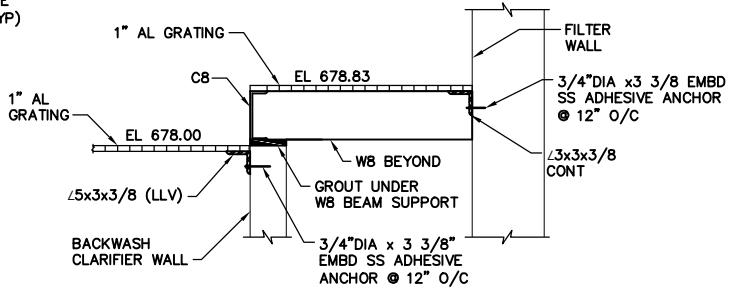

SECTION B  
S9 S9  
NOT TO SCALE

- NOTES:
1. PUMP BASE PLATE SHALL BE ANCHORED TO W8 BEAM. THE SIZE OF PUMP BASE PLATE AND ANCHORS SHALL BE AS PER THE REQUIREMENT OF PUMP MFR.
  2. NO STRUCTURAL STEEL MEMBER SHALL BE FABRICATED UNLESS PUMP BASE PLATE SUPPORTING DETAIL IS APPROVED.
  3. W8 = W8x31  
C8 = C8x11.5  
L3 = L3x3x3/8
  4. ALL STRUCTURAL STEEL MEMBERS SHALL BE HOT DIPPED GALVANIZED.

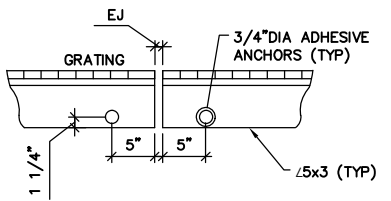

GRATING SUPPORTING DETAIL AT EXISTING WALL EXPANSION JOINT  
NOT TO SCALE

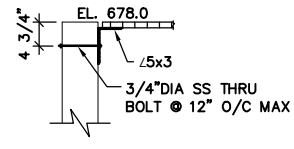

GRATING SUPPORTING DETAIL AT EXISTING WALL  
NOT TO SCALE

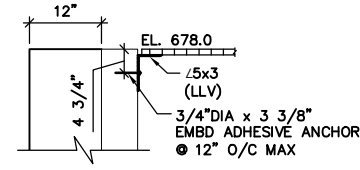

DETAIL 1  
C6 S9  
NOT TO SCALE



REVISIONS			
NO.	BY	DATE	REMARKS

DES TBD  
DWN HBD  
CRD TBD

COVINA IRRIGATING COMPANY  
GLENORA, CALIFORNIA  
**UV/CHLORAMINES FOR TEMPLE WTP**

TEMPLE WATER TREATMENT PLANT  
**BACKWASH CLARIFIER**  
**PARTIAL PLANS AND DETAILS**  
SCALE: AS NOTED

COPYRIGHT © 2009  
MALCOLM PIRNIE, INC.  
DATE NOVEMBER 2009  
S SHEET 9 OF 9  
CAD REF. NO. 5324A084

XREFS: \\XREF\MGP\UVF.dwg; \\XREF\SGP\UVF.dwg; \\XREF\3324-TBLK.dwg; IMAGES: None; User: Strahota; Spec: PIRNIE\_STANDARD; File: \\ACAD\PROJ\5324002\Covina\_MECH\5324A080.DWG; Scale: 1:1; Date: 06/29/2009; Time: 09:26; Layout: M-5



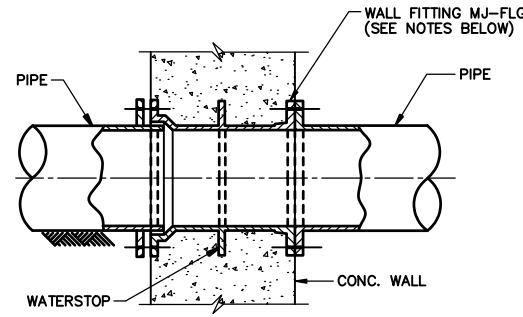

- NOTES:**
1. THE DETAIL APPLIES TO MJ-FLG (SHOWN), MJ-MJ, FLG-FLG, MJ-PE, FLG-PE, FLG-GROOVED, PE-GROOVED, OR PE-PE FITTINGS. FLANGES SHALL BE TAPPED TO ALLOW INSTALLATION BETWEEN WALL FORMS.
  2. UNLESS OTHERWISE IDENTIFIED ON CIVIL OR MECHANICAL DRAWINGS.
  3. BOLT HOLES SHALL STRADDLE HORIZONTAL AND VERTICAL CENTER LINES.
  4. WALL FITTING INTERIOR LINING/COATING SHALL MATCH THAT OF CONNECTING PIPES.

**WALL AND FLOOR PIPE FITTING**

DETAIL 

1
- GM1

  
NOT TO SCALE

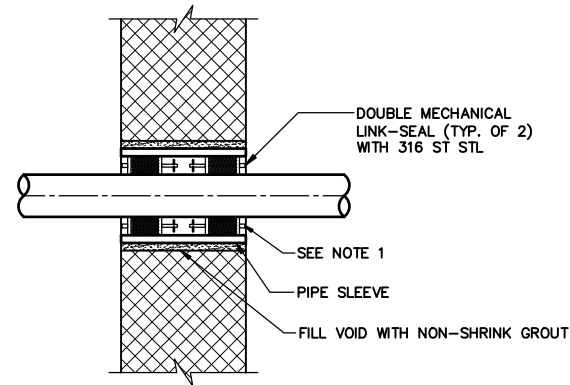

- NOTE:**
1. FILL ANNULAR SPACE AROUND PIPE WITH SIKA FLEX 1A SEALANT FLUSH WITH CONCRETE WALL/SLAB BOTH SIDES.

**PIPE SLEEVE THRU MASONRY WALL**

DETAIL 

2
- GM1

  
NOT TO SCALE

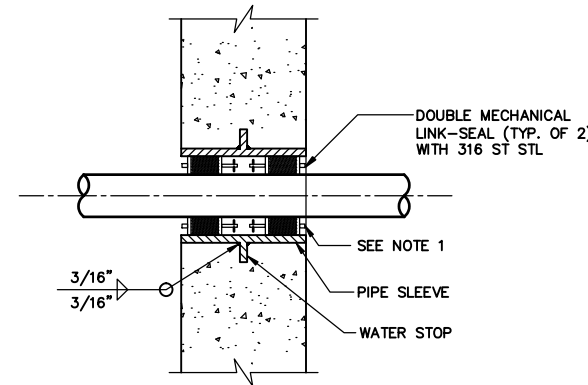

- NOTE:**
1. FILL ANNULAR SPACE AROUND PIPE WITH SIKA FLEX 1A SEALANT FLUSH WITH CONCRETE WALL/SLAB BOTH SIDES.

**PIPE SLEEVE THRU WALLS & SLAB**

DETAIL 

3
- GM1

  
NOT TO SCALE

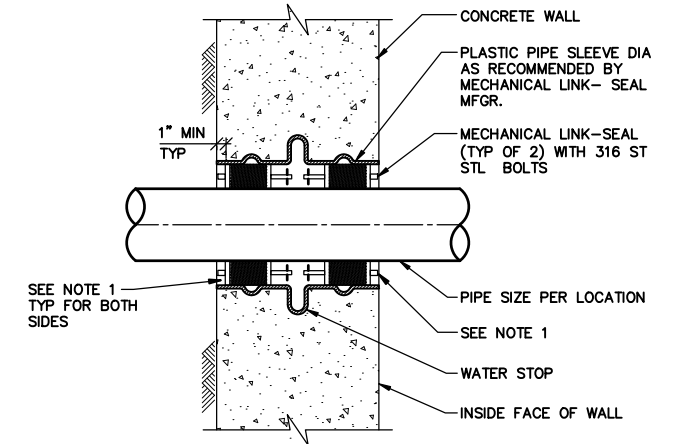

- NOTE:**
1. DRY PACK ANNULAR SPACE AROUND PIPE WITH NON-SHRINK EPOXY GROUT FLUSH WITH CONCRETE WALL-SLAB BOTH SIDES.

**PIPE SLEEVE THRU NEW CONCRETE WALL BELOW GRADE OR BELOW WATER SURFACE**

DETAIL 

5
- GM1

  
NOT TO SCALE

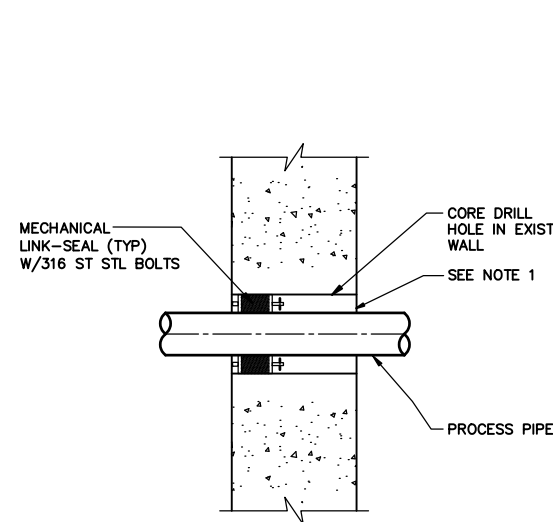

- NOTES:**
1. PROVIDE DUAL LINK SEALS WHERE PIPE PENETRATION IS BELOW GRADE OR SUBMERGED BELOW WATER SURFACE.

**WALL PENETRATION THRU EXIST CONCRETE**

DETAIL 

6
- GM1

  
NOT TO SCALE

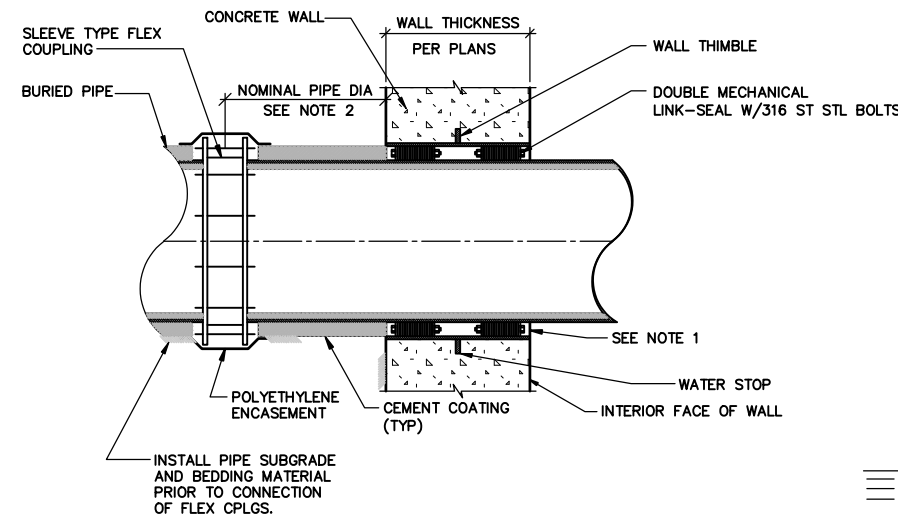

- NOTES:**
1. FILL ANNULAR SPACE AROUND PIPE WITH SIKA FLEX 1A SEALANT FLUSH WITH CONCRETE WALL/SLAB BOTH SIDES.
  2. UNLESS OTHERWISE IDENTIFIED ON CIVIL OR MECHANICAL DRAWINGS.

**CML&C STEEL PIPE WALL PENETRATION**

DETAIL 

7
- GM1

  
NOT TO SCALE

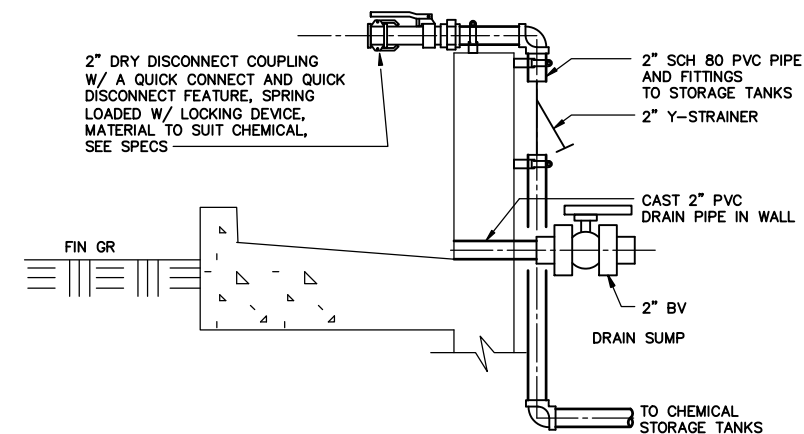

**TYPICAL CHEMICAL FILL STATION**

DETAIL 

8
- GM1

  
NOT TO SCALE

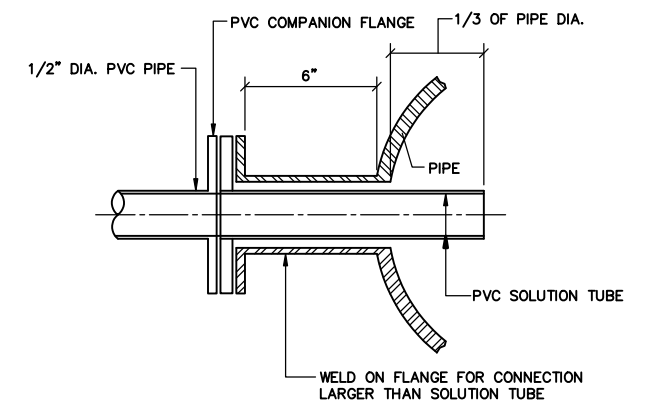

**CHEMICAL SOLUTION DIFFUSER DETAIL**

DETAIL 

9
- GM1

  
NOT TO SCALE



REVISIONS			
NO.	BY	DATE	REMARKS

DES MS  
DWN AR  
CKD JB

COVINA IRRIGATING COMPANY  
GLEN DORA, CALIFORNIA  
**UV/CHLORAMINES FOR TEMPLE WTP**

TEMPLE WATER TREATMENT PLANT  
**MECHANICAL DETAILS 1**  
NOT TO SCALE

COPYRIGHT © 2009  
MALCOLM PIRNIE, INC.  
DATE DECEMBER 2009  
GM SHEET 1 OF 2  
CAD REF. NO. 5324A100

XREFS: \\XREF\5324-TBLK.dwg IMAGES: None User: Strahota Spec: PIRNIE STANDARD File: \\CAD\PROJ\5324A100.DWG Scale: 1:1 Date: 12/04/2009 Time: 08:34 Layout: GM-1

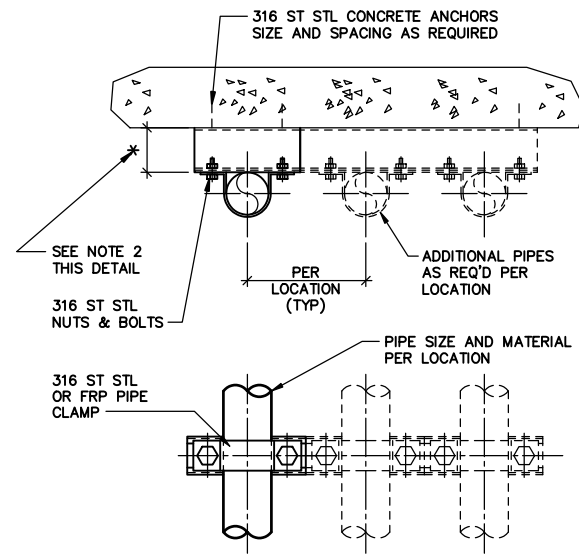

NOTES:

- SUPPORT CHANNEL AND PIPE CLAMP SHALL BE UNISTRUT, POWERSTRUT, AICKIN STRUT OR EQUAL.
- PROVIDE MULTIPLE CHANNELS BACK-TO-BACK TO OBTAIN REQUIRED DISTANCE PER LOCATION.
- SUPPORT MAY BE MOUNTED ON WALL, FLOOR OR CEILING.

PIPE SUPPORT

DETAIL 1  
- GM2  
NOT TO SCALE

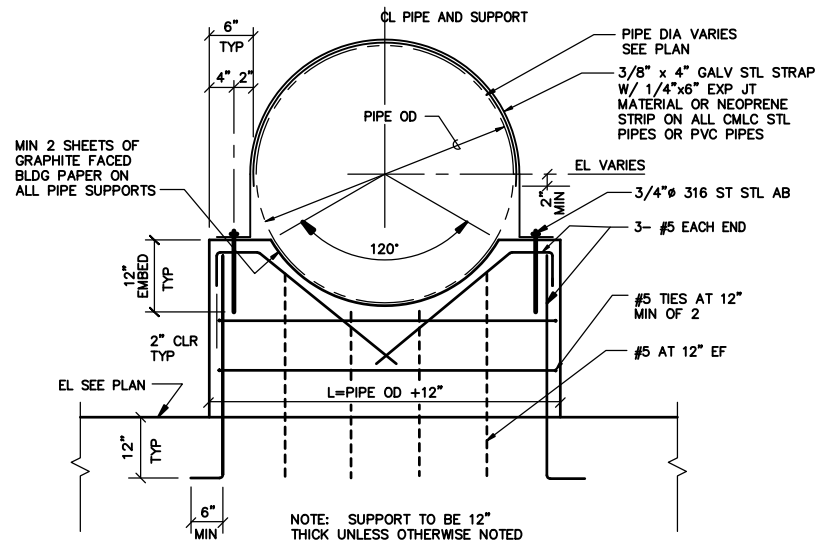

TYPICAL CONCRETE SADDLE SUPPORT

DETAIL 2  
- GM2  
NOT TO SCALE

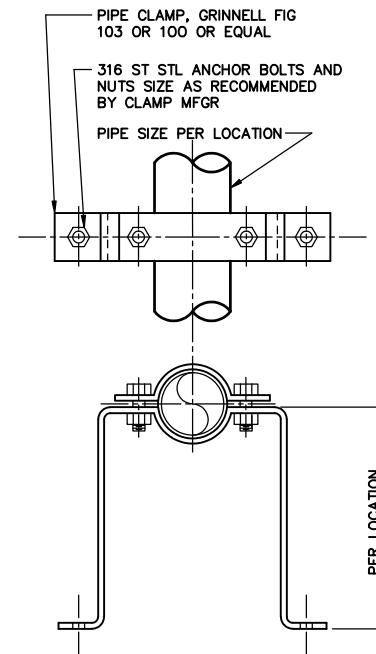

OFFSET PIPE CLAMP

DETAIL 3  
- GM2  
NOT TO SCALE

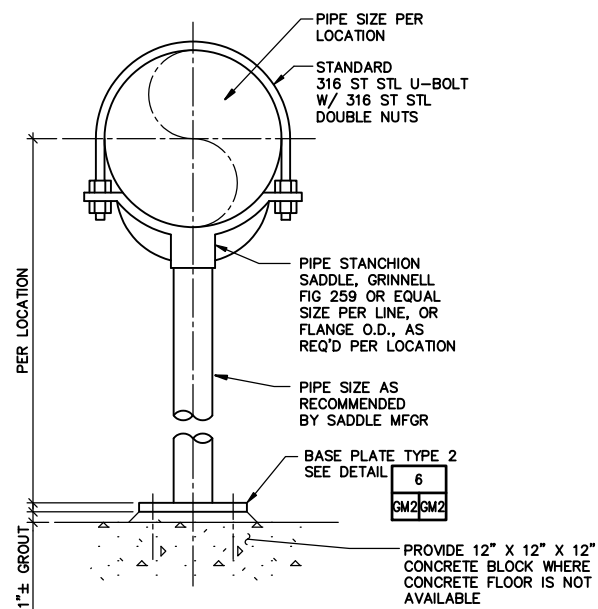

PIPE STANCHION SADDLE

DETAIL 4  
- GM2  
NOT TO SCALE

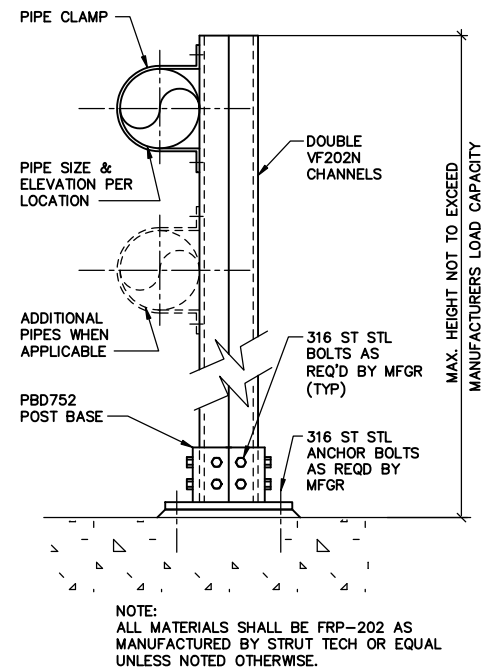

NON-METALLIC SUPPORT

DETAIL 5  
- GM2  
NOT TO SCALE

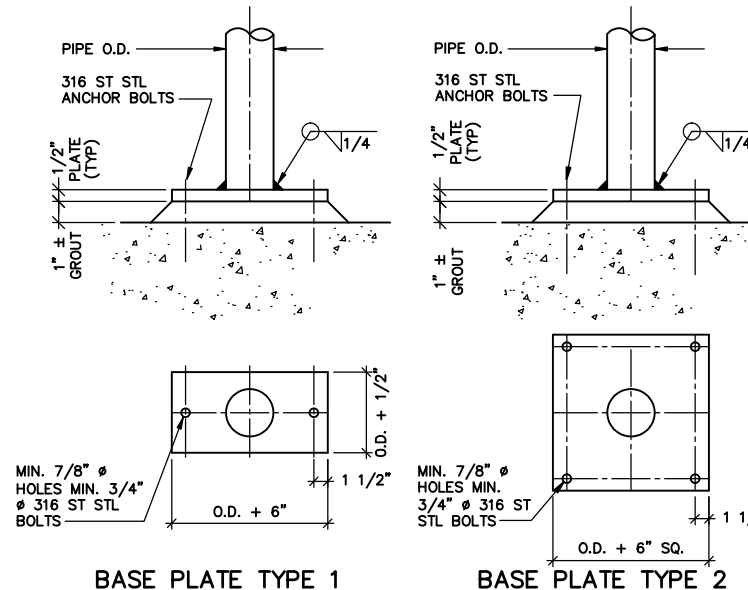

BASE PLATE & FLOOR MOUNTING

DETAIL 6  
- GM2  
NOT TO SCALE

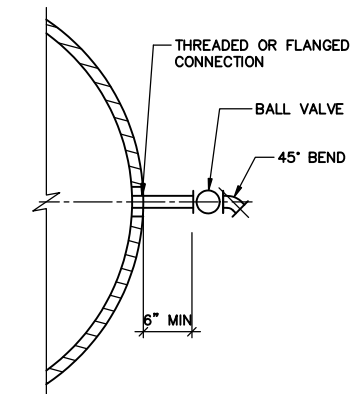

SAMPLE CONNECTION

DETAIL 7  
- GM2  
NOT TO SCALE

GENERAL NOTES:

- ALL ANCHORING AND ANCHORING ATTACHMENTS AND PIPE ATTACHMENTS SHALL BE 316 ST STL.
- WHERE NO REFERENCES TO PIPE SUPPORT SYSTEMS ARE GIVEN ON THE DRAWINGS, THE CONTRACTOR SHALL USE AN APPROPRIATE SYSTEM PER THE CONTRACT DOCUMENTS.
- CONTRACTOR SHALL BE RESPONSIBLE FOR FURNISHING AND INSTALLING PIPE SUPPORTS AND ANCHORING SYSTEMS ADEQUATELY SIZED TO SUPPORT ALL LOADS IMPOSED BY THE PIPING SYSTEM PER THE CONTRACT DOCUMENTS. WHERE REFERENCED PIPE SUPPORT DETAILS ARE INADEQUATE FOR SPECIFIC LOADS, THE CONTRACTOR SHALL DESIGN, FURNISH AND INSTALL PIPE SUPPORTS ADEQUATE TO SUPPORT LOADS AT RESPECTIVE LOCATIONS.
- ALL SUPPORTS SHALL BE SET FLUSH TO SURFACE OR BASE TO WHICH ANCHORED. METHODS USED SHALL BE SUBMITTED PER THE SPECIFICATIONS.
- STRUCTURAL ATTACHMENTS INTO BLOCK WALLS SHALL BE INSTALLED IN GROUDED CELLS ONLY.
- THE DETAILS SHOWN ON THE CONTRACT DOCUMENTS INDICATE THE GENERAL METHODS OF SUPPORT UNDER NORMAL CONDITIONS. IT SHALL BE THE RESPONSIBILITY OF THE CONTRACTOR TO DEVELOP AND SUBMIT FOR REVIEW AND APPROVAL FINAL SUPPORT SYSTEM DETAILS PER THE CONTRACT DOCUMENTS.
- THE CONTRACTOR SHALL UTILIZE ALL PIPE SUPPORTS IN STRICT CONFORMANCE WITH THE MANUFACTURER'S RECOMMENDATIONS.
- THE CONTRACTOR SHALL UTILIZE, WHEREVER POSSIBLE, STANDARD OFF-THE-SHELF STOCK PIPE SUPPORTS SUPPLIED BY APPLICABLE MANUFACTURERS AS SPECIFIED IN THE CONTRACT DOCUMENTS.
- ALL SUPPORTS THAT ARE SUBMERGED, OR OTHERWISE EXPOSED TO THE INTERIOR ATMOSPHERIC CONDITIONS OF HYDRAULIC AND/OR STORAGE STRUCTURES, OR LOCATED IN CLASS 1, GROUP D, DIVISION 1, CLASSIFIED (SEE SPECIFICATIONS DIVISION 16) AREAS OR LOCATED IN CHEMICAL CONTAINMENT AREAS, SHALL BE 316 ST STL.
- ALL SUPPORTS THAT ARE NON-SUBMERGED, EXTERIOR SUPPORTS WITH NO EXPOSURE TO INTERIOR ATMOSPHERIC CONDITIONS ABOVE THE WATER SURFACE IN HYDRAULIC STRUCTURES, SHALL BE HOT-DIP GALVANIZED.
- ALL PIPE SUPPORTS LOCATED IN CHEMICAL CONTAINMENT AREAS SHALL BE 316 ST STL OR CORROSION-RESISTANT FIBERGLASS REINFORCED POLYESTER (FRP).
- PROTECTION OF DISSIMILAR MATERIALS SHALL BE AS SPECIFIED.
- ALL ANCHOR BOLTS SHALL BE CAST-IN-PLACE.
- ALL ANCHOR BOLT SIZES SHOWN ARE MINIMUM REQUIREMENTS. CONTRACTOR SHALL VERIFY ANCHOR BOLT SIZES AT EACH LOCATION.

XREFS: \\XREF\5324-TBLK.dwg IMAGES: None User: grios Spec: PIRNIE STANDARD File: \\CAD\PROJ\5324A101.DWG Scale: 1:1 Date: 12/03/2009 Time: 15:08 Layout: GM-2



REVISIONS			
NO.	BY	DATE	REMARKS

DES	MS
DWN	AR
CKD	JB

COVINA IRRIGATING COMPANY  
 GLENDORA, CALIFORNIA  
**UV/CHLORAMINES FOR TEMPLE WTP**

TEMPLE WATER TREATMENT PLANT  
**MECHANICAL DETAILS 2**  
 NOT TO SCALE

COPYRIGHT © 2009  
 MALCOLM PIRNIE, INC.  
 DATE: DECEMBER 2009  
 GM SHEET 2 OF 2  
 CAD REF. NO. 5324A101

XREFS: \\VREF\MGR\UVF.dwg; \\VREF\SGP\UVF.dwg; \\VREF\5324-TBLK.dwg; IMAGES: None  
 User: Stranaha Spec: PIRNIE STANDARD File: \\CAD\PROJ\5324A076.DWG Scale: 1:1 Date: 06/29/2009 Time: 19:12 Layout: M-1

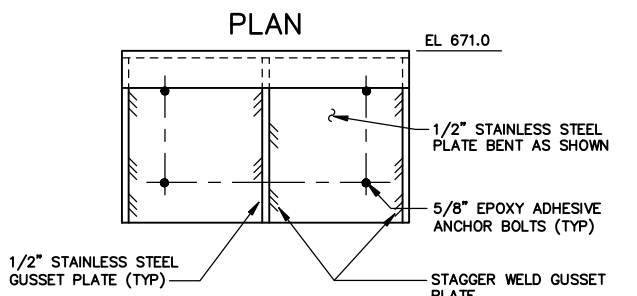
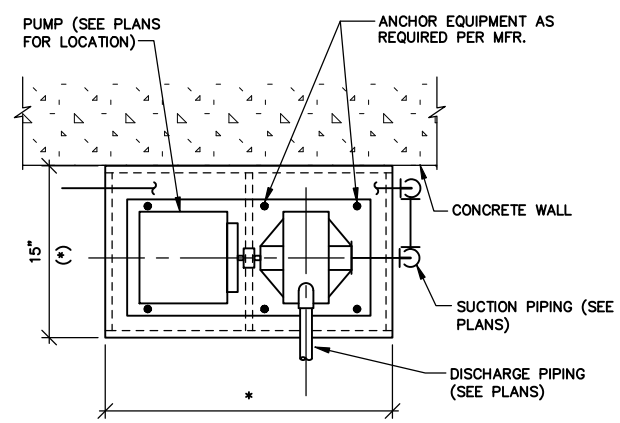
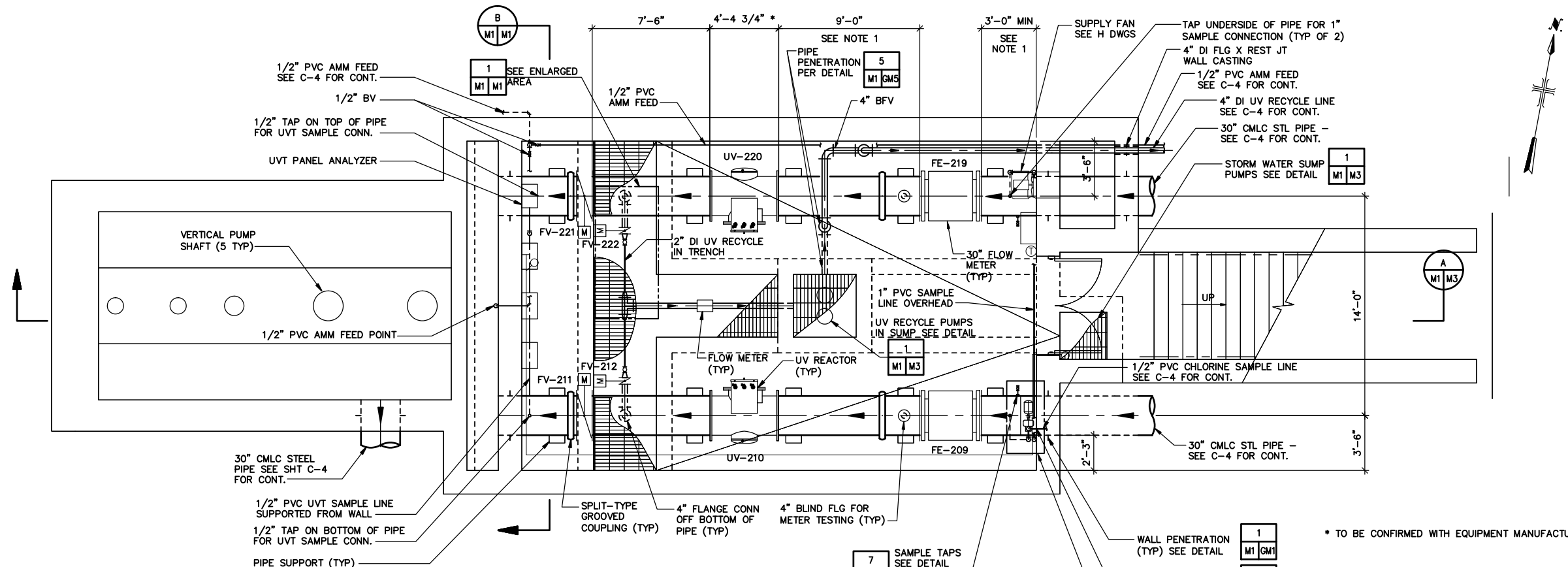

- NOTES:**
1. ALL MATERIALS TO BE TYPE 316 STAINLESS STEEL.
  2. ALL CORNERS AND EDGES TO BE ROUNDED SMOOTH.
  3. DIMENSIONS SHOWN MAY VARY DEPENDING UPON ACTUAL EQUIPMENT SELECTED.

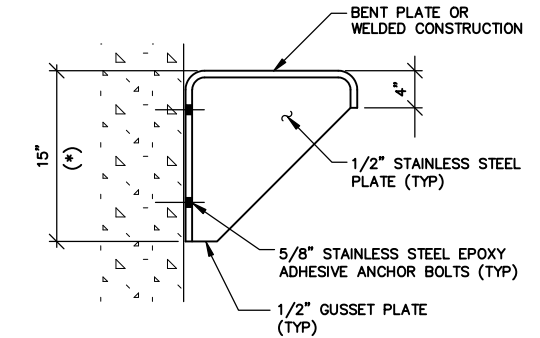

**PUMP SUPPORT BRACKET DETAIL**

DETAIL 2  
M1 M1  
NOT TO SCALE

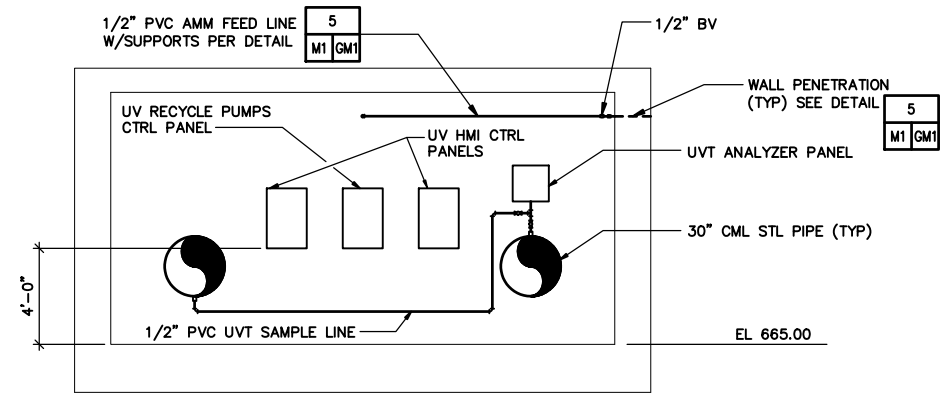

**SECTION B**  
M1 M1  
SCALE: 1/4"=1'-0"

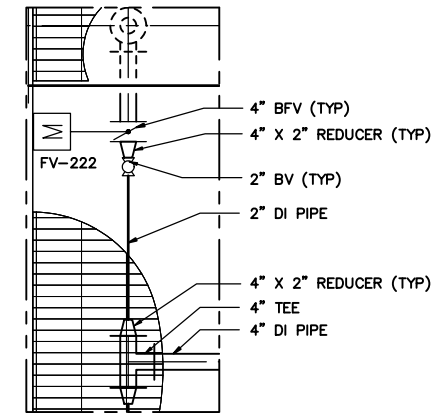

**ENLARGED AREA 1**  
M1 M1  
SCALE: 1/2"=1'-0"

\* TO BE CONFIRMED WITH EQUIPMENT MANUFACTURER

- NOTES:**
1. PIPE CONNECTING FLOW METER SHALL EXACTLY MATCH THE INSIDE DIAMETER OF FLOW METER.

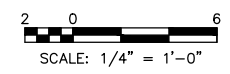

REVISIONS			
NO.	BY	DATE	REMARKS

DES	MS
DWN	AR
CKD	JB

COVINA IRRIGATING COMPANY  
 GLENDORA, CALIFORNIA  
**UV/CHLORAMINES FOR TEMPLE WTP**

TEMPLE WATER TREATMENT PLANT  
**UV FACILITY**  
**LOWER LEVEL PLAN**  
 SCALE: 1/4"=1'-0"

COPYRIGHT © 2009  
 MALCOLM PIRNIE, INC.  
 DATE: DECEMBER 2009  
 M SHEET 1 OF 7  
 CAD REF. NO. 5324A076

XREFS: \\XREF\MGR\UVF.dwg .. \XREF\SGPLUVF.dwg .. \XREF\5324-TBLK.dwg IMAGES: None  
 User: Strahota Spec: PIRNIE STANDARD File: \\CAD\PROJ\5324002 Covina\MECH\5324A077.DWG Scale: 1:1 Date: 06/29/2009 Time: 20:11 Layout: M-2

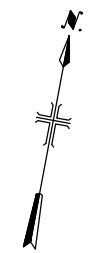
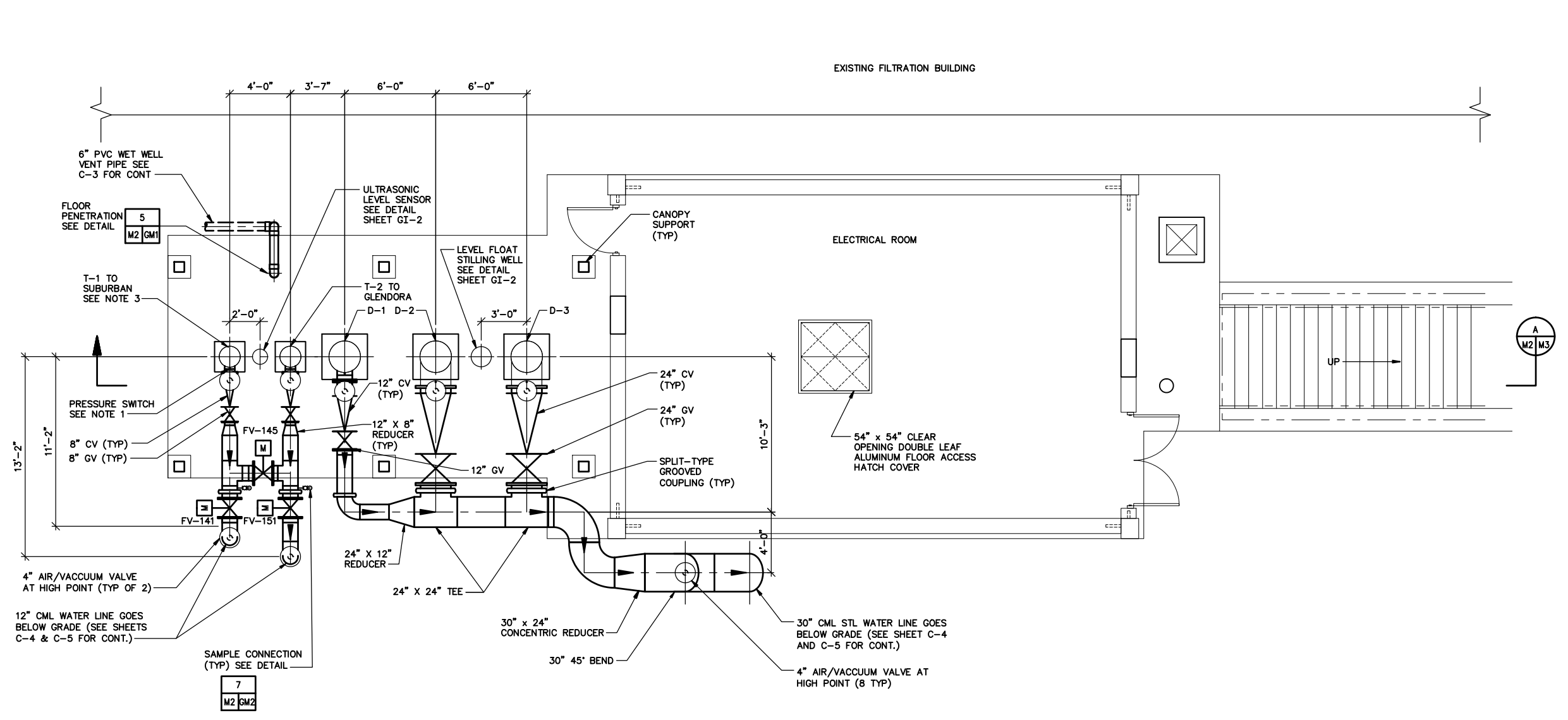

- NOTES:**
1. PRESSURE SWITCH SHALL BE PROVIDED ON ALL PUMP DISCHARGES UPSTREAM OF CV. PROVIDE SPOOL PIECE AS REQUIRED. SUBMIT PRESSURE SWITCH LOCATIONS WITH PIPING SUBMITTALS IN ACCORDANCE WITH SPEC SECTION 15052.
  2. PIPE SUPPORTS SHALL BE PER DETAIL 4 M2 GM2
  3. T-1 PUMP AND ASSOCIATED PIPING, NOT INCLUDING VALVE FV-145, ARE PART OF BID ITEM 5-SUBURBAN WATER SYSTEMS FACILITIES IMPROVEMENTS.

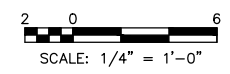

REVISIONS			
NO.	BY	DATE	REMARKS

DES MS  
 DWN AR  
 CKD JB

COVINA IRRIGATING COMPANY  
 GLENDORA, CALIFORNIA  
**UV/CHLORAMINES FOR TEMPLE WTP**

TEMPLE WATER TREATMENT PLANT  
**UV FACILITY**  
**UPPER LEVEL PLAN**  
 SCALE: 1/4"=1'-0"

COPYRIGHT © 2009  
 MALCOLM PIRNIE, INC.  
 DATE DECEMBER 2009  
 M SHEET 2 OF 7  
 CAD REF. NO. 5324A077

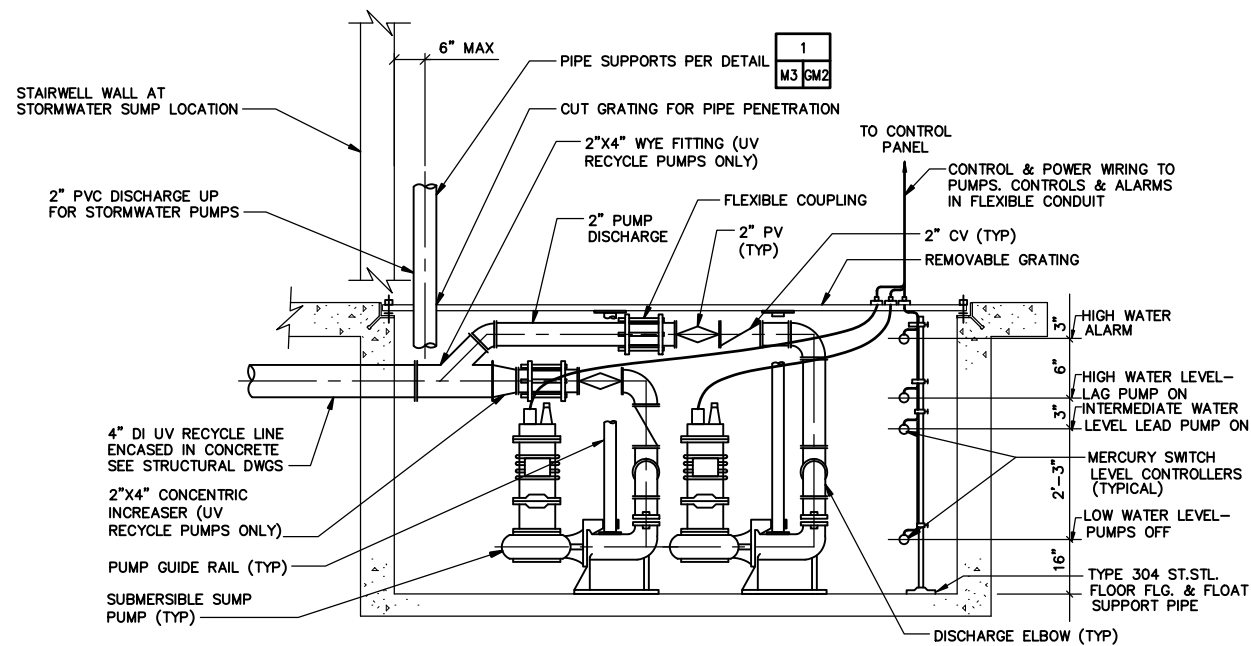
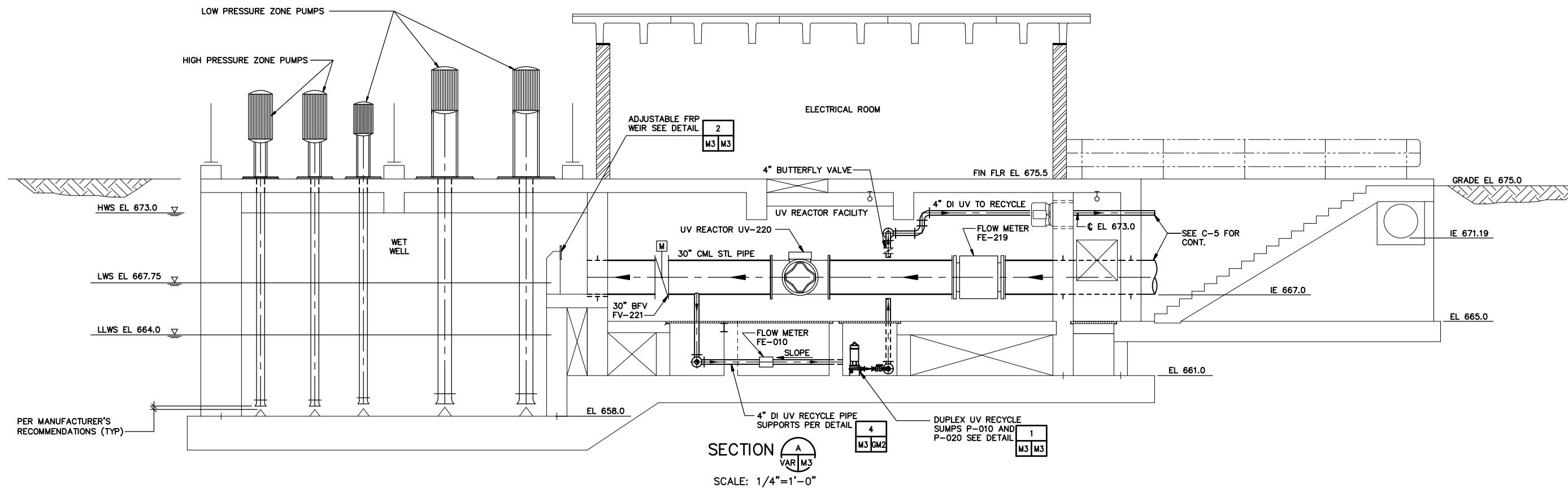

UV RECYCLE AND STORMWATER SUMP PUMPS

DETAIL 1  
VAR M3  
NOT TO SCALE

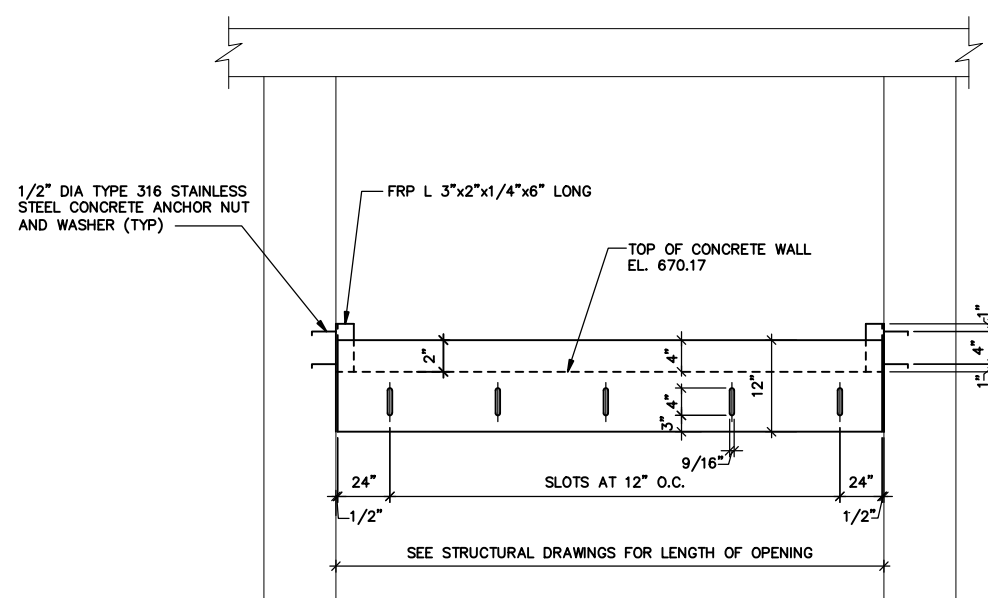

ELEVATION

ADJUSTABLE FRP WEIR PLATE

DETAIL 2  
M3 M3  
NOT TO SCALE

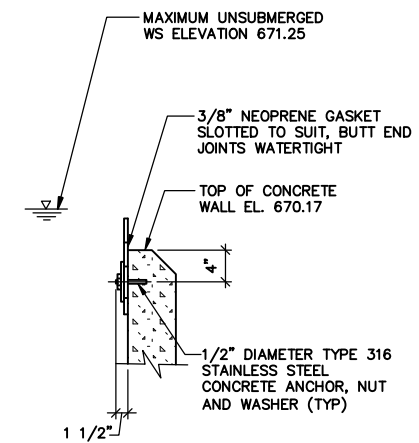

SECTION



NO.		BY	DATE	REVISIONS	REMARKS

DES MS  
DWN AR  
CKD JB

COVINA IRRIGATING COMPANY  
GLENORA, CALIFORNIA  
**UV/CHLORAMINES FOR TEMPLE WTP**

TEMPLE WATER TREATMENT PLANT  
**UV FACILITY**  
**SECTIONS AND DETAILS**  
SCALE: 1/4"=1'-0"

COPYRIGHT © 2009  
MALCOLM PIRNIE, INC.  
DATE: DECEMBER 2009  
M SHEET 3 OF 7  
CAD REF. NO. 5324A078

XREFS: \\VREF\MGR\UVF.dwg; \\VREF\SGP\UVF.dwg; \\VREF\5324-TBLK.dwg; IMAGES: None; User: carlos; Spec: PIRNIE; STANDARD; File: I:\CAD\PROJ\5324A078.DWG; Scale: 1:1; Date: 06/29/2009; Time: 15:38; Layout: M-3

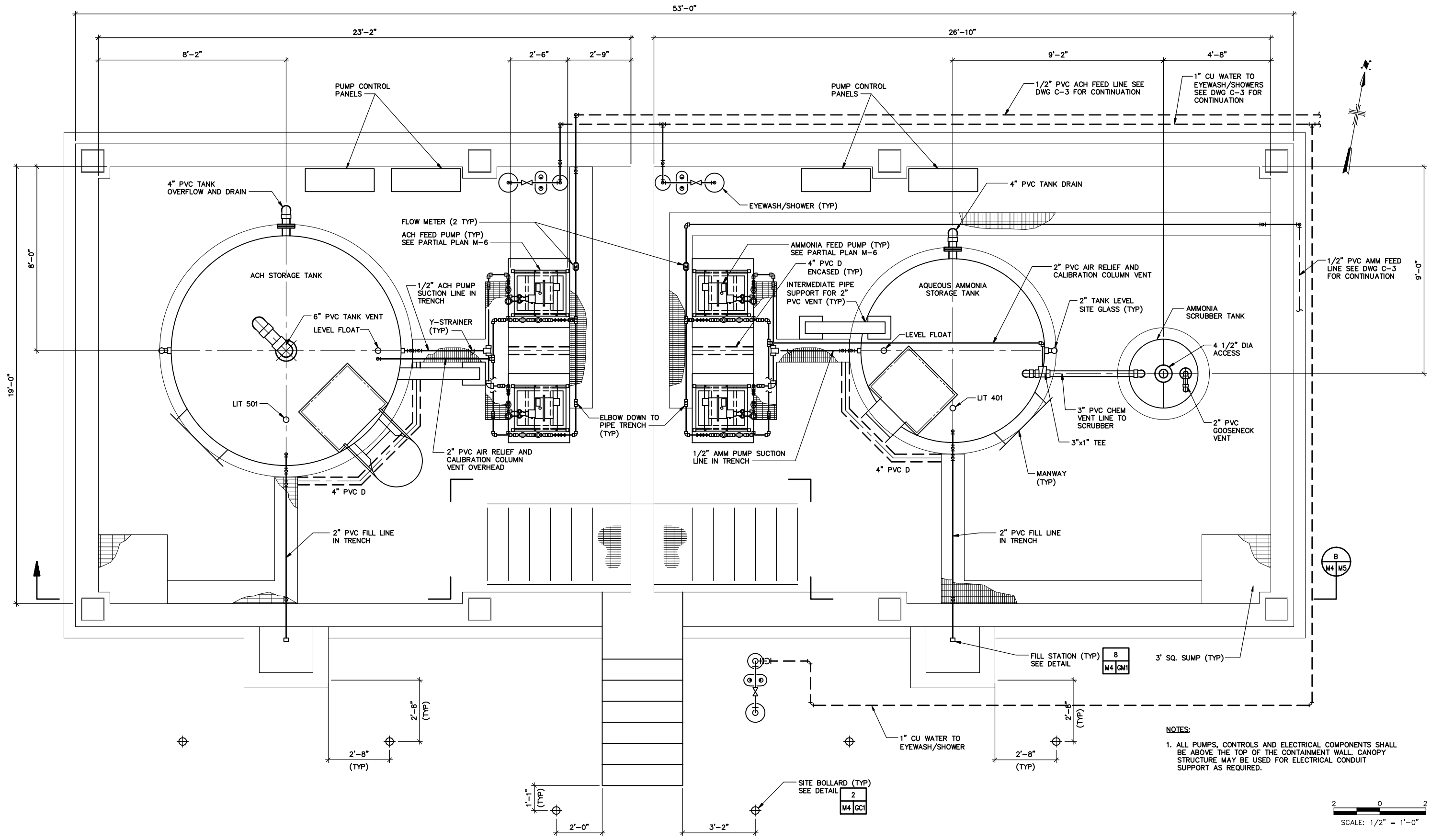

**NOTES:**  
 1. ALL PUMPS, CONTROLS AND ELECTRICAL COMPONENTS SHALL BE ABOVE THE TOP OF THE CONTAINMENT WALL. CANOPY STRUCTURE MAY BE USED FOR ELECTRICAL CONDUIT SUPPORT AS REQUIRED.

SCALE: 1/2" = 1'-0"

XREFS: \\VREF\WGPCHEM.dwg - VREF\SGPCHEM.dwg - VREF\5324-TBL.dwg IMAGES: None  
 \\VREF\WGPCHEM.dwg - VREF\SGPCHEM.dwg - VREF\5324-TBL.dwg  
 11/15/2009 10:00:00 AM 11/15/2009 10:00:00 AM



REVISIONS			
NO.	BY	DATE	REMARKS

DES. TD  
 DWN. AR  
 CKD. MS

COVINA IRRIGATING COMPANY  
 GLENDORA, CALIFORNIA  
**UV/CHLORAMINES FOR TEMPLE WTP**

TEMPLE WATER TREATMENT PLANT  
**CHEMICAL FACILITY PLAN**  
 SCALE: 1/2"=1'-0"

COPYRIGHT © 2009  
 MALCOLM PIRNIE, INC.  
 DATE: DECEMBER 2009  
 M SHEET 4 OF 7  
 CAD REF. NO. 5324A079

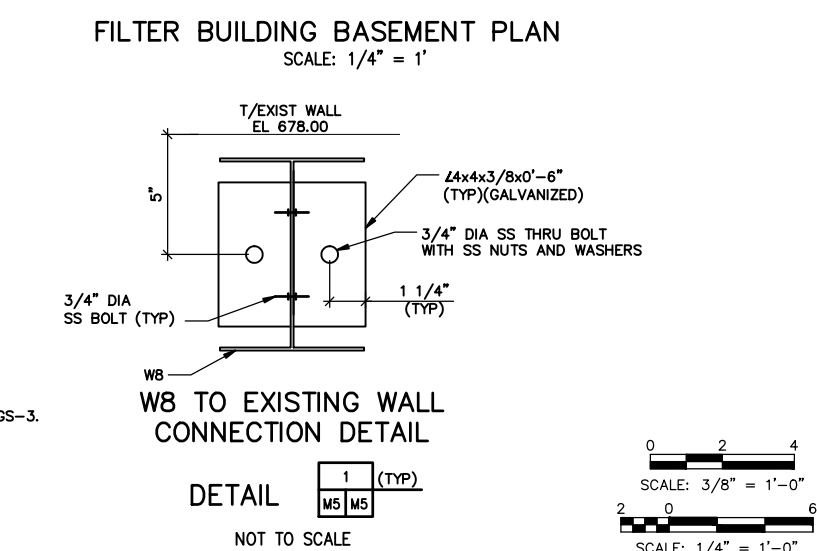
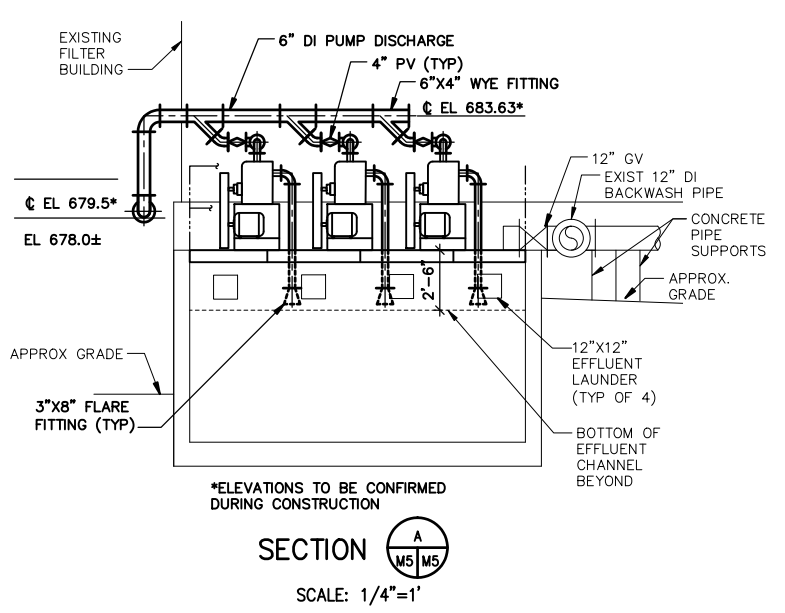
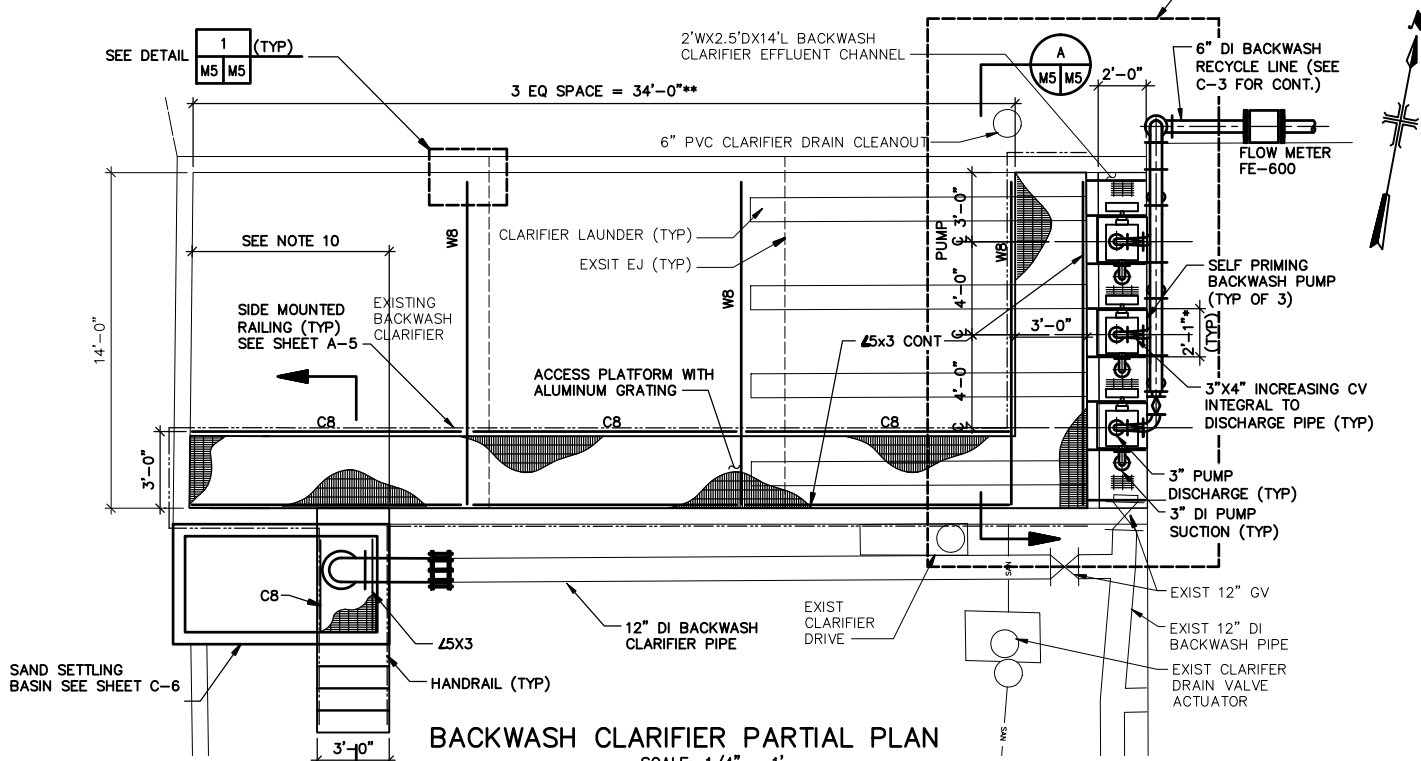
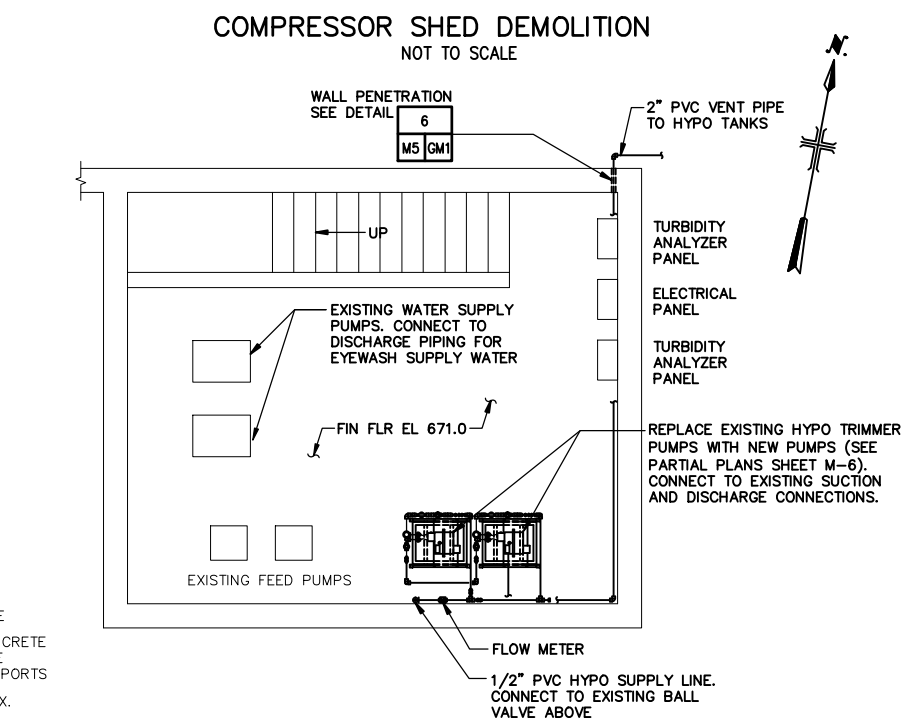
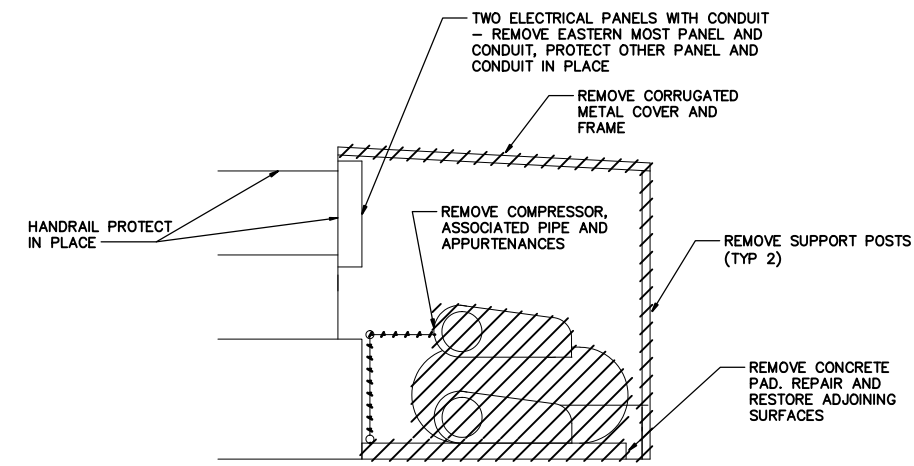
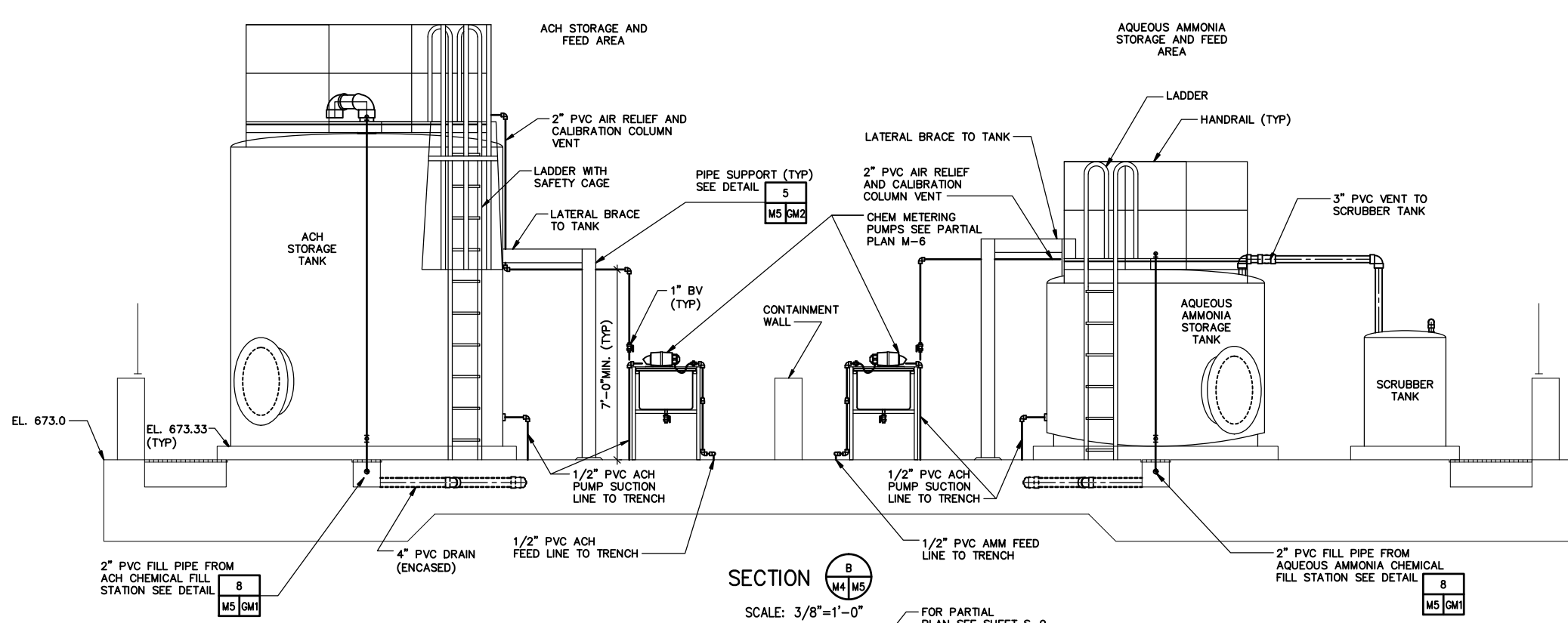

- GRATING NOTES:**
- DESIGN LL = 100 PSF.
  - C8 = C8x11.5, L5x3 = L5x3x3/8
  - W8 = W8x24
  - ALL STRUCTURAL STEEL SHALL BE HOT DIP GALVANIZED.
  - L5x3 SHALL BE STOPPED BEFORE THE EXPANSION JOINT IN WALL. SEE GRATING SUPPORTING DETAIL AT EXISTING WALL EXPANSION JOINT ON SHEET S-9.

- PROVIDE HORIZONTAL LONG SLOTTED HOLES FOR C8 TO W8 CONNECTION.
- HANDRAIL SHALL BE PROVIDED WITH EXPANSION JOINTS AS NEEDED AT THE LOCATION OF EXPANSION JOINT IN EXISTING WALL.
- ALL GRATING SHALL BE 1\"/>



REVISIONS			
NO.	BY	DATE	REMARKS

DES MS  
DWN AR  
CKD JB

COVINA IRRIGATING COMPANY  
GLENORA, CALIFORNIA  
**UV/CHLORAMINES FOR TEMPLE WTP**

TEMPLE WATER TREATMENT PLANT  
**CHEMICAL FACILITY SECTIONS  
AND MISCELLANEOUS DETAILS**  
SCALE: AS NOTED

COPYRIGHT © 2009  
MALCOLM PIRNIE, INC.  
DATE: DECEMBER 2009  
M SHEET 5 OF 7  
CAD REF. NO. 5324A080

User:Strancho Spec:PIRNE STANDARD File: \\CAD\PROJ\5324A080.DWG Scale: 1:1 Date: 06/28/2009 Time: 09:26 Layout: M-5

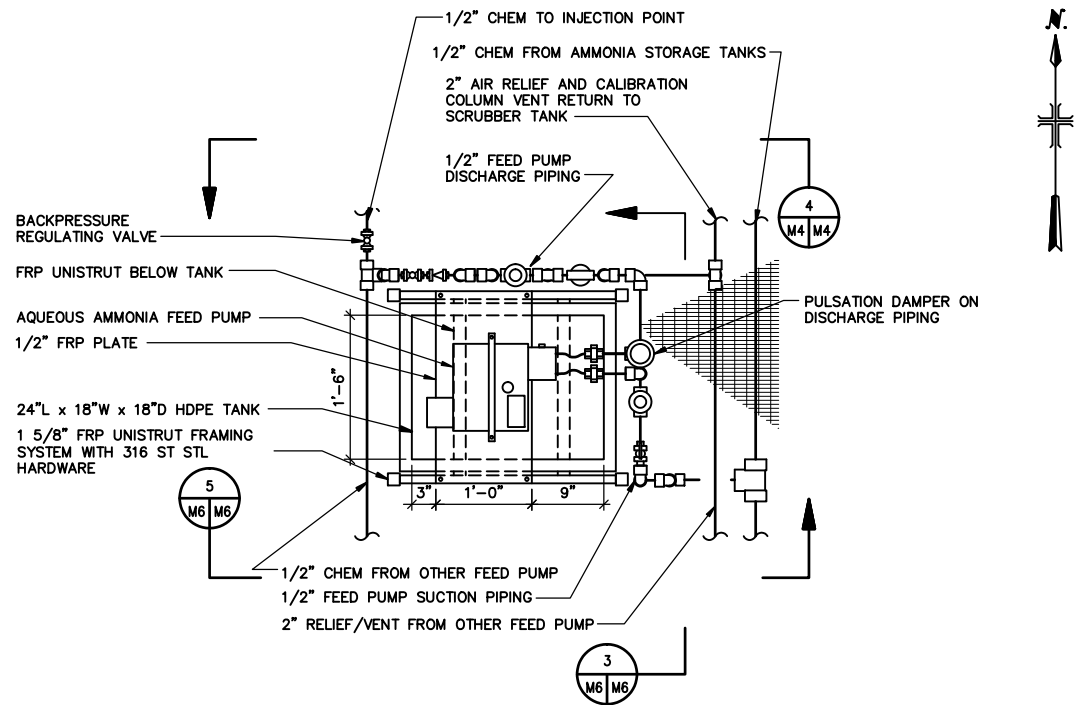

AMMONIA/ACH/SODIUM HYPOCHLORITE FEED PUMP PARTIAL PLAN  
SCALE: 1"=1'-0"

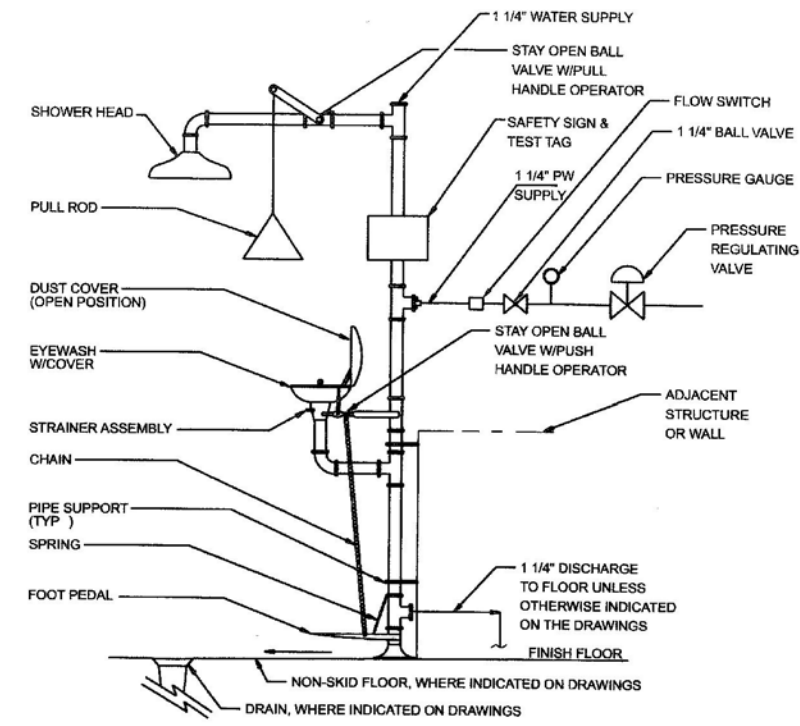

NOTES: INSTALL DIELECTRIC UNION BETWEEN DISSIMILAR METALS FOR MFR, MATERIALS, MODEL SEE SPEC. SECTION 15430

EYEWASH AND SHOWER DETAIL

DETAIL 1/M6

NOT TO SCALE

NOTES:

- ARRANGEMENT SHOWN IN SECTIONS 3, 4 AND 5 IS FOR THE AQUEOUS AMMONIA FEED PUMPS. ACH/SODIUM HYPOCHLORITE ARRANGEMENT IS SIMILAR.
- PIPING, VALVES AND APPURTENANCES ON SUCTION AND DISCHARGE OF CHEMICAL FEED PUMPS SHALL BE SECURELY MOUNTED TO THE FRP UNISTRUT SYSTEM.
- FOR SODIUM HYPOCHLORITE PUMPS, FRP UNISTRUT FRAMING SYSTEM WILL CONSIST OF TOP 1'-11" SHOWN IN SECTIONS 3, 4 AND 5 ANCHORED ON TOP OF EXISTING CONCRETE PAD. DRAIN PIPING TO BE ROUTED ACCORDINGLY.

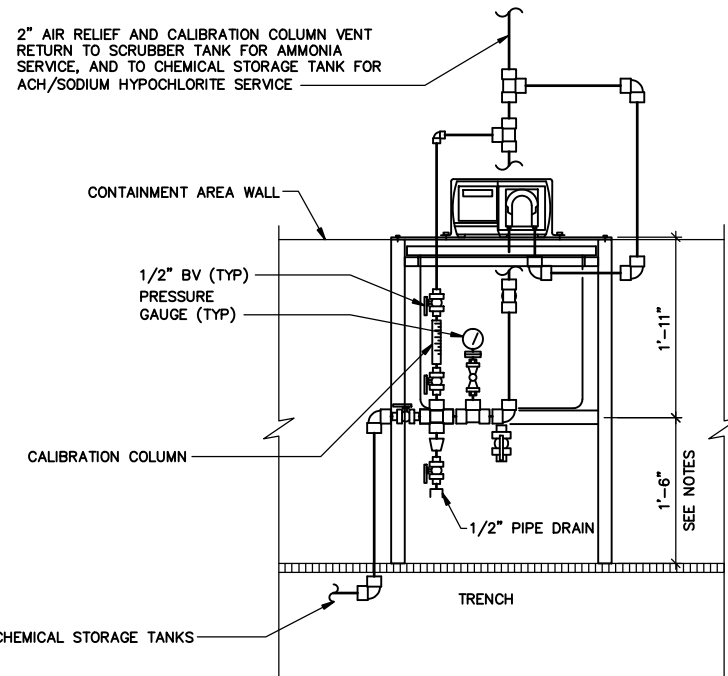

SECTION 3  
SCALE: 1" = 1'-0"

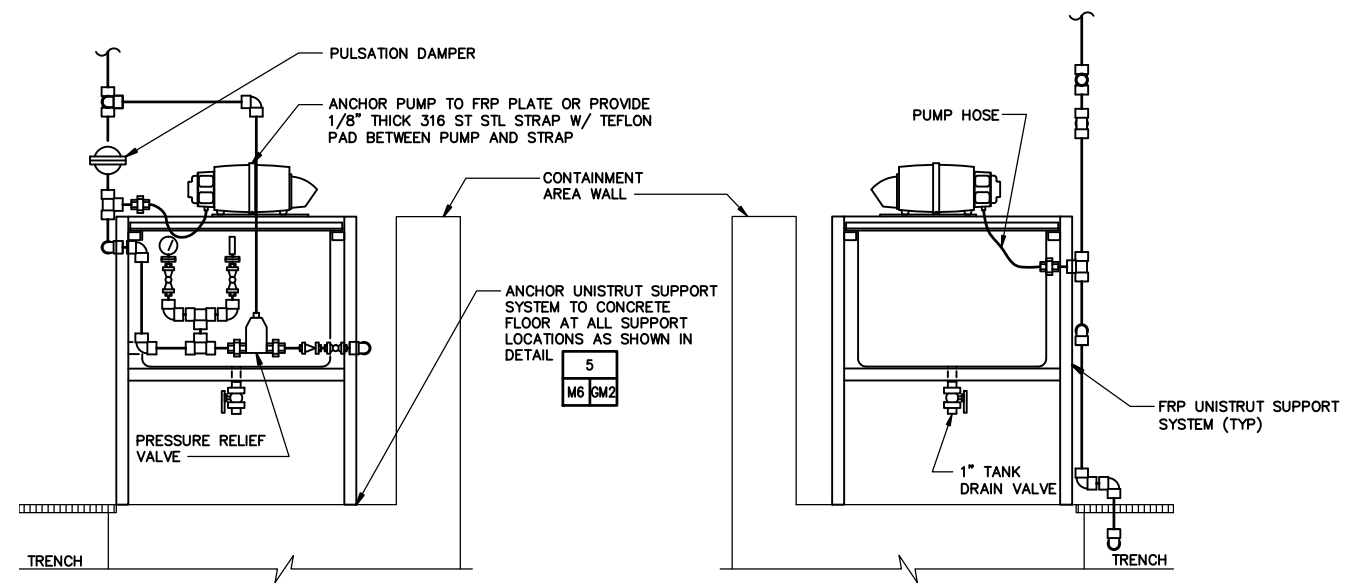

SECTION 4  
SCALE: 1" = 1'-0"

SECTION 5  
SCALE: 1" = 1'-0"

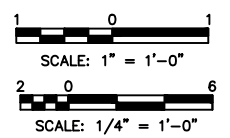

XREFS: \\XREF\5324-TBLK.dwg IMAGES: \\XREF\emergency\power.tif User: Strahota Spec: PIRNIE STANDARD File: \\CAD\PROJ\5324\02 Covina\MECH\5324A081.DWG Scale: 1:1 Date: 12/04/2009 Time: 08:37 Layout: M-6



REVISIONS			
NO.	BY	DATE	REMARKS

DES MS  
DWN AR  
CKD JB

COVINA IRRIGATING COMPANY  
GLENORA, CALIFORNIA  
**UV/CHLORAMINES FOR TEMPLE WTP**

TEMPLE WATER TREATMENT PLANT  
**CHEMICAL FEED PUMP PARTIAL PLANS AND SECTIONS**  
SCALE: 1/4"=1'-0"

COPYRIGHT © 2009  
MALCOLM PIRNIE, INC.  
DATE: DECEMBER 2009  
M SHEET 6 OF 7  
CAD REF. NO. 5324A081



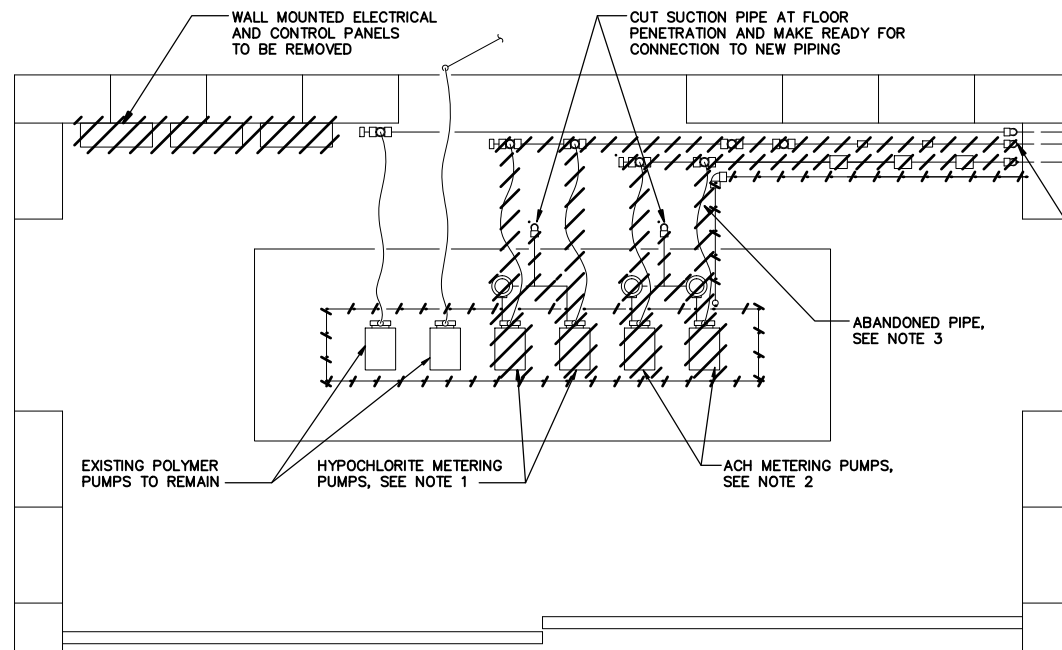

METERING PUMP ENCLOSURE DEMOLITION PLAN

SCALE: 3/4"=1'-0"

NOTES:

1. REMOVE HYPOCHLORITE METERING PUMPS, SUCTION AND DISCHARGE PIPE AND APPURTENANCES. MAKE SUCTION PIPE IN FLOOR READY FOR CONNECTION TO NEW PIPING.
2. REMOVE ACH METERING PUMPS, SUCTION AND DISCHARGE, PIPE AND APPURTENANCES. CUT AND CAP SUCTION PIPE AT FLOOR PENETRATION.
3. REMOVE ABANDONED PIPING. CUT AND CAP PIPE END AT WALL.

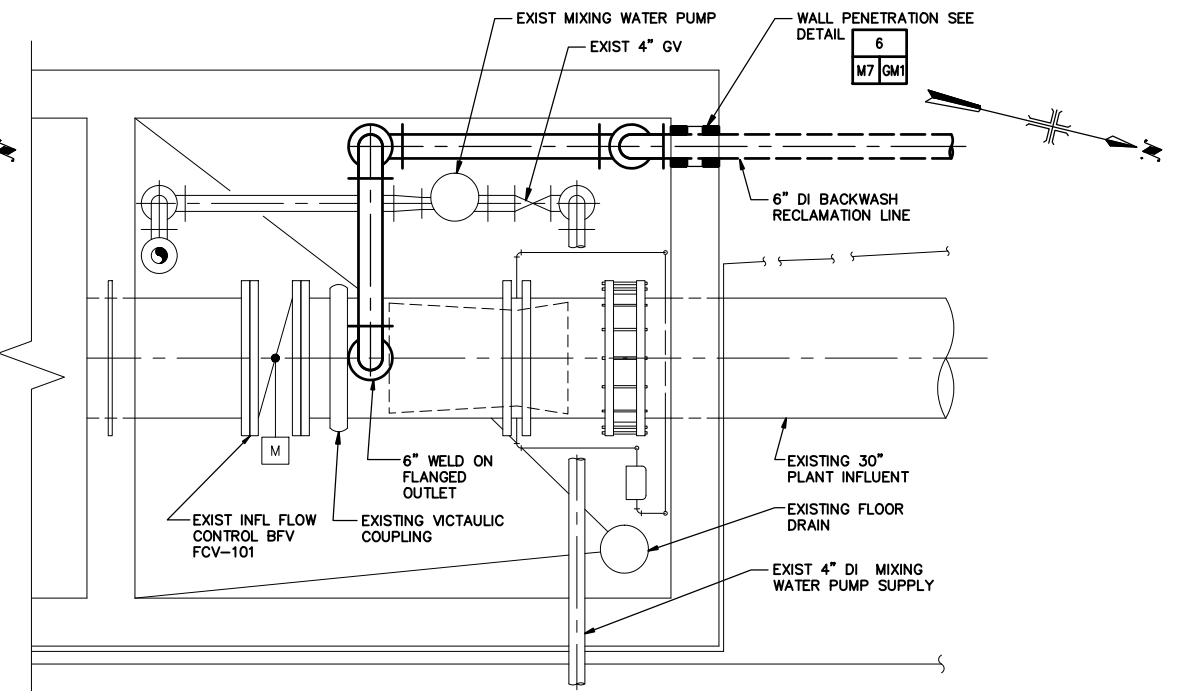

METER STRUCTURE PARTIAL PLAN

SCALE: 1/2"=1'-0"

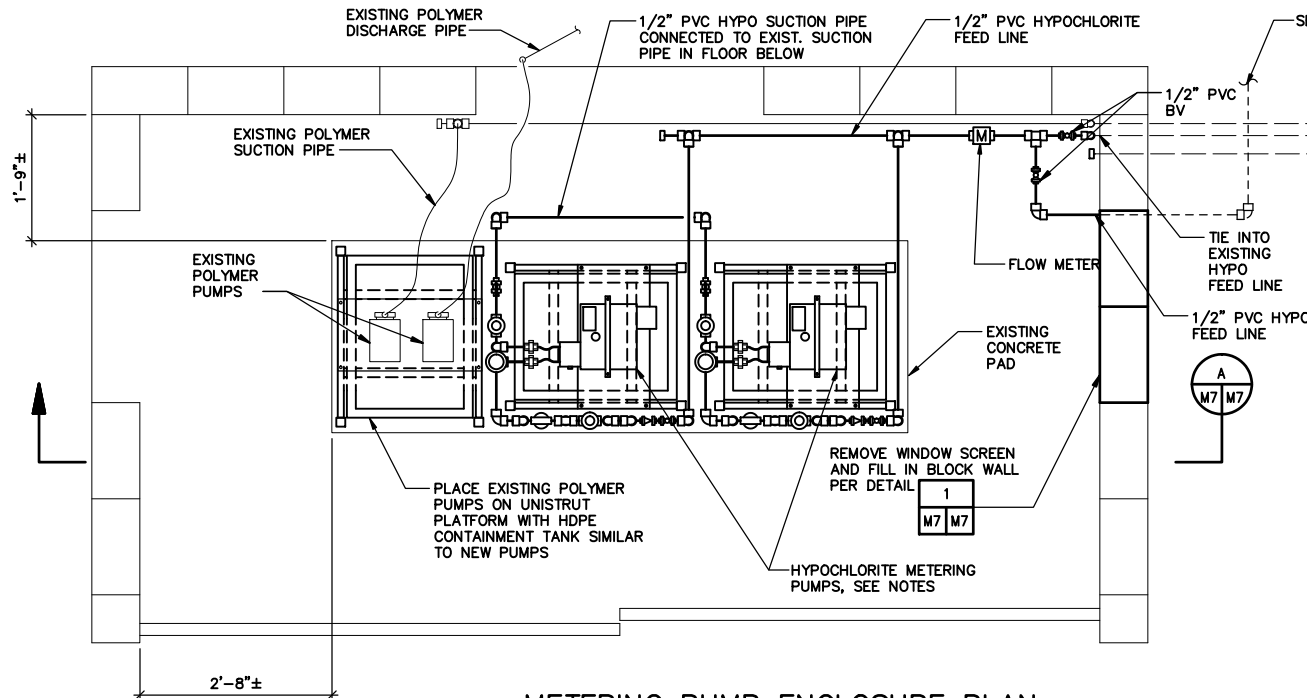

METERING PUMP ENCLOSURE PLAN

SCALE: 3/4"=1'-0"

NOTES:

1. INSTALL NEW HYPOCHLORITE METERING PUMPS, SUCTION AND DISCHARGE PIPE AND APPURTENANCES. SEE PARTIAL PLANS ON DWG M-6.
2. CONSTRUCT ONLY TOP 1'-11" SECTION OF PLATFORM SHOWN IN PARTIAL PLANS ON DWG M-6 FOR METERING PUMPS IN THIS ENCLOSURE. ANCHOR NEW PLATFORMS TO EXISTING CONCRETE PAD.

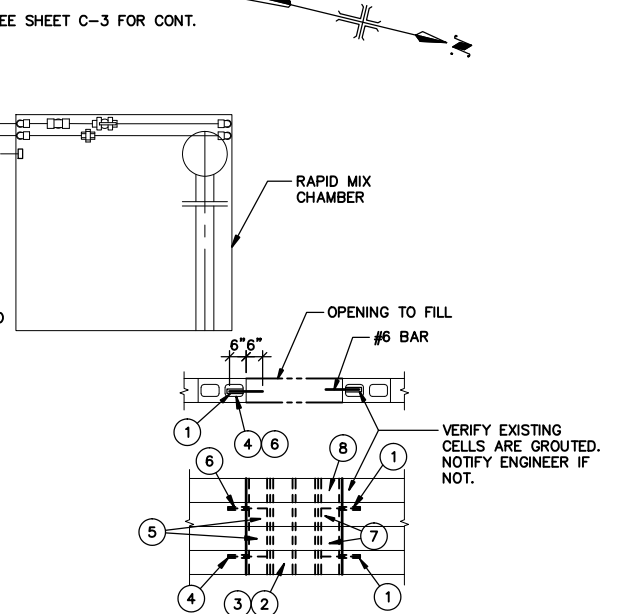

DETAIL

NOT TO SCALE

NOTES:

1. DRILL HOLES IN EXIST. CMU FOR ADHESIVE ANCHOR DOWELS.
2. NOTCH WEBS OF CMU UNITS TO ALLOW INSERTION OF ADHESIVE DOWELS.
3. PLACE BLOCK LAYER @ DOWEL LEVEL.
4. INJECT EPOXY INTO HOLE & SET DOWEL. LET EPOXY CURE.
5. PLACE BLOCKS UP TO THE NEXT DOWEL LOCATION.
6. FILL HOLE W/EPOXY & SET DOWEL. ALLOW TO CURE.
7. FILL CELLS WITH DOWELS WITH GROUT.
8. PLACE TOP OF ROW OF BLOCKS.

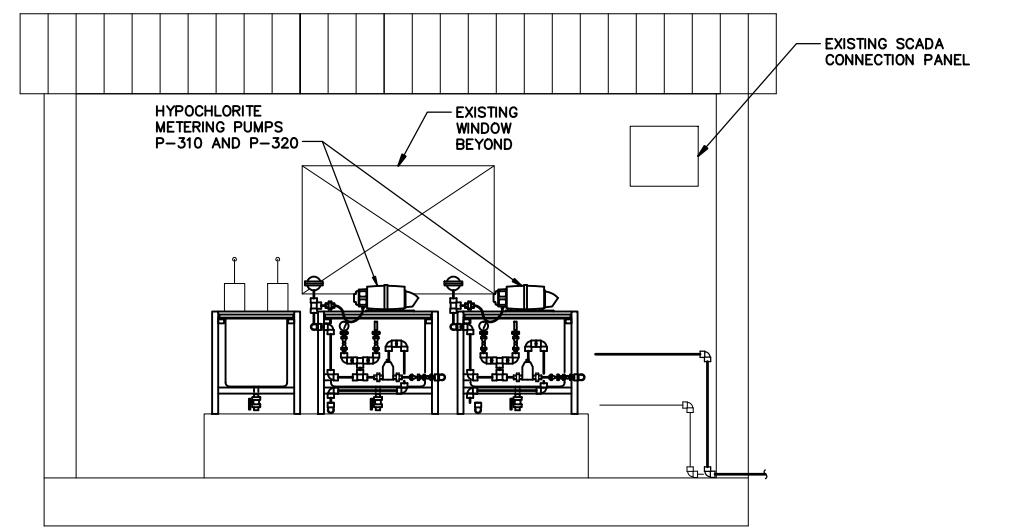

SECTION

SCALE: 1/2"=1'-0"

XREFS: \\VREF\MGR\UVF.dwg; \\VREF\SGP\UVF.dwg; \\VREF\5324-TBLK.dwg IMAGES: None Scale: 1:1 Date: 04/08/2009 Time: 09:39 Layout: M-7 User: carlos Spec: PIRNIE STANDARD File: \\CAD\PROJ\5324\02 Covina\MECH\5324A082.DWG



REVISIONS			
NO.	BY	DATE	REMARKS

DES TD  
DWN AR  
CKD MS

COVINA IRRIGATING COMPANY  
GLENORA, CALIFORNIA  
**UV/CHLORAMINES FOR TEMPLE WTP**

TEMPLE WATER TREATMENT PLANT  
**METERING PUMP ENCLOSURE/  
INFLUENT VAULT PLANS AND SECTION**  
SCALE: AS NOTED

COPYRIGHT © 2009  
MALCOLM PIRNIE, INC.  
DATE DECEMBER 2009  
M SHEET 7 OF 7  
CAD REF. NO. 5324A082

ABBREVIATIONS

HVAC

Table of HVAC abbreviations including AD (ACCESS DOOR), AL (ALUMINUM), AFF (ABOVE FINISHED FLOOR), etc.

Table of HVAC abbreviations including SP (STATIC PRESSURE), SRV (SAFETY RELIEF VALVE), SR (SUPPLY REGISTER), etc.

EQUIPMENT

Table of HVAC equipment abbreviations including ACU (AIR CONDITIONING UNIT), ACCU (AIR COOLED CONDENSING UNIT), etc.

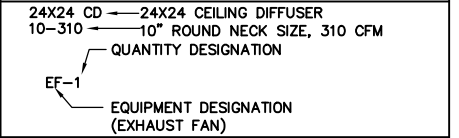

Table of HVAC abbreviations including FC (FLEXIBLE CONNECTION), FD (FIRE DAMPER), FO (FUEL OIL), etc.

PIPING SYMBOLS

Table of piping symbols including HWS (HOT WATER SUPPLY), HWR (HOT WATER RETURN), CA (COMPRESSED AIR), etc.

Table of piping symbols including ISOLATION VALVE, BUTTERFLY VALVE, CHECK VALVE, GATE VALVE, GLOBE VALVE, etc.

MISCELLANEOUS SYMBOLS

Table of miscellaneous symbols including T, RS (THERMOSTAT/TEMPERATURE SENSOR), PUMP OR FAN.

DUCTWORK SYMBOLS

Table of ductwork symbols including SUPPLY AIR, RETURN OR EXHAUST AIR, DUCT, DIRECTION OF FLOW, SIZE, etc.

GENERAL NOTES

- GENERAL NOTES: 1. THE SYMBOLS AND ABBREVIATIONS LIST ON THIS SHEET IS A COMPREHENSIVE STANDARD GUIDE... 2. ALL DUCT DIMENSIONS ARE CLEAR DIMENSIONS TO INSIDE OF DUCT...

XREFS: None IMAGES: None User: Chhea Spec: PIRNIE\_STANDARD File: C:\Documents and Settings\chhea\Desktop\Covina UV Chloramines WTP\Covina HVAC\53244501.DWG Scale: 1:1 Date: 07/20/2009 Time: 08:25 Layout: H02



Table with columns: NO., BY, DATE, REVISIONS, REMARKS.

Table with columns: DES, SC; DWN, SC; CKD, VV.

COVINA IRRIGATING COMPANY
GLEN DORA, CALIFORNIA
UV/CHLORAMINES FOR TEMPLE WTP

TEMPLE WATER TREATMENT PLANT
SYMBOLS, ABBREVIATIONS, AND
GENERAL NOTES
SCALE: NONE

COPYRIGHT © 2009
MALCOLM PIRNIE, INC.
DATE: DECEMBER 2009
H SHEET 1 OF 3
CAD REF. NO. 5324H501

AIR CONDITIONING UNIT SCHEDULE																											
MARK NO.	LOCATION	SERVICE	EVAP./ SUPPLY FAN DATA						DX COOLING COIL DATA @ 95°F O.A.			COMPRESSOR DATA					CONDENSOR SECTION			FILTER DATA	ELECTRICAL DATA		APPROX. WEIGHT (LBS)	DESIGN BASE		NOTES	
			TOTAL AIRFLOW (CFM)	O.A FLOW (CFM)	ESP (IN W.G.)	MOTOR DATA			CAPACITY TOTAL/SENS. (MBH)	EAT DB/WB (°F)	LAT DB/WB (°F)	TYPE	NO.	RLA	LRA	V/PH	TONS	FANS			TYPE	TOTAL POWER MCA		V/PH	MFR		MODEL
						HP	RPM	V/PH										NO.	MOTOR HP EACH	V/PH							
AC-1	EXTERIOR WALL OF ELECTRICAL ROOM	ELECTRICAL ROOM	2050	0	0.25	3/4	1075	208/1	71/47	80/67	55/54	SCROLL	1	10.6	75.0	460/3	6	1	1/2	208/1	PLEATED	17.3	460/3	700	MARVAIR	AVPA72AC-COMPAC II	1, 2, 3
AC-2	EXTERIOR WALL OF ELECTRICAL ROOM	ELECTRICAL ROOM	2050	0	0.25	3/4	1075	208/1	71/47	80/67	55/54	SCROLL	1	10.6	75.0	460/3	6	1	1/2	208/1	PLEATED	17.3	460/3	700	MARVAIR	AVPA72AC-COMPAC II	1, 2, 3

NOTES:  
1. FACTORY INSTALLED DISCONNECT 2. CONDENSER COIL COATING 3. ECONOMIZER

FAN SCHEDULE															
MARK NO.	LOCATION	SERVICE	TYPE	DRIVE	AIRFLOW (CFM)	ESP (IN. W.G.)	SPEED (RPM)	MOTOR DATA				APPROX. WEIGHT (LBS)	DESIGN BASE		NOTES
								HP	BHP	RPM	V/PH		MFR	MODEL	
SF-1	LOWER LEVEL	LOWER LEVEL - O.A. SUPPLY	PROPELLER	DIRECT	1592	0.5	1725	1/2	.504	1725	460/3	150	COOK	16A17DBS	

NOTES:

VENT SCHEDULE													
MARK NO.	LOCATION	SERVICE	TYPE	DESIGN BASE		AIR FLOW (CFM)	NO. OF TIERS	THROAT SIZE LXW (IN)	HOOD AREA (SQ. FT.)	MAX HOOD VELOCITY (FPM)	MAX PRESSURE DROP (IN W.G.)	APPROX. WEIGHT (LBS)	NOTES
				MFR	MODEL								
IV-1	GRADE	SF-1	INTAKE	COOK	TRE	1500	3	24X24	5.4	300	0.1	100	1

NOTES:  
1. MOUNTED ON CONCRETE CURB.

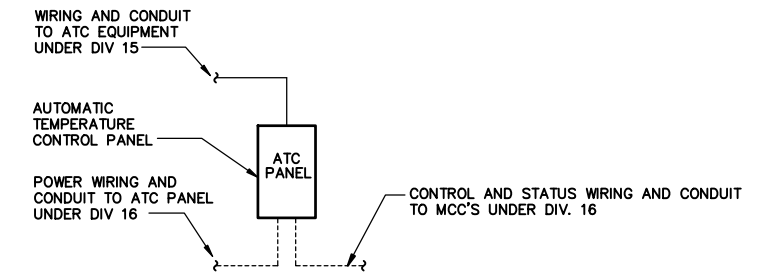

ATC PANEL SCHEMATIC

XREFS:None IMAGES:None User:hillis Spec:PIRNF STANDARD File: \\CAD\PROJ\5324002 Covina\PIRNF\53244502.DWG Scale:1:1 Date:07/24/2009 Time:13:13 Layout:H02



REVISIONS			
NO.	BY	DATE	REMARKS

DES SC  
DWN SC  
CKD VV

COVINA IRRIGATING COMPANY  
 GLENDORA, CALIFORNIA  
**UV/CHLORAMINES FOR TEMPLE WTP**

TEMPLE WATER TREATMENT PLANT  
**DETAILS, CONTROL SCHEMATICS, AND EQUIPMENT SCHEDULE**  
 SCALE: NONE

COPYRIGHT © 2009 MALCOLM PIRNIE, INC.  
 DATE DECEMBER 2009  
 H SHEET 2 OF 3  
 CAD REF. NO. 5324H502

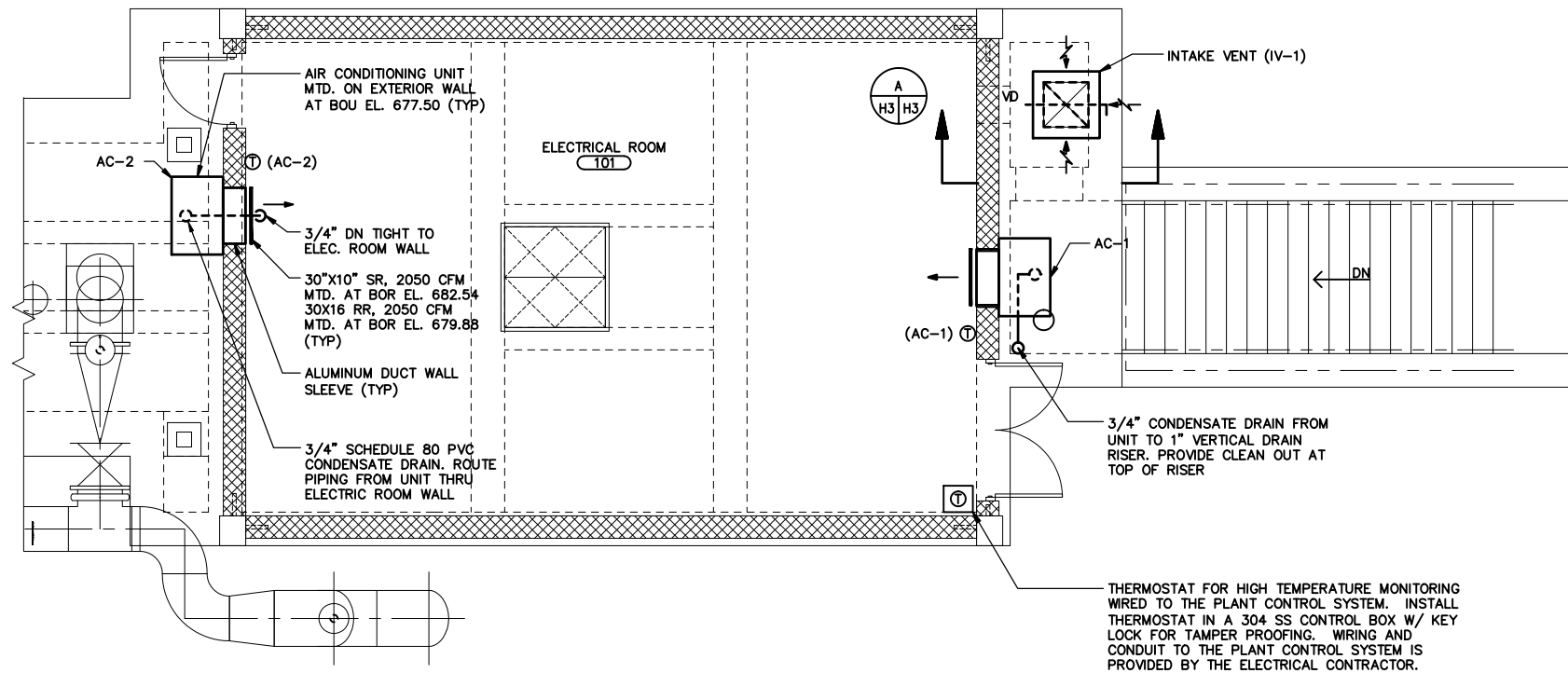

FLOOR PLAN AT EL 675.50

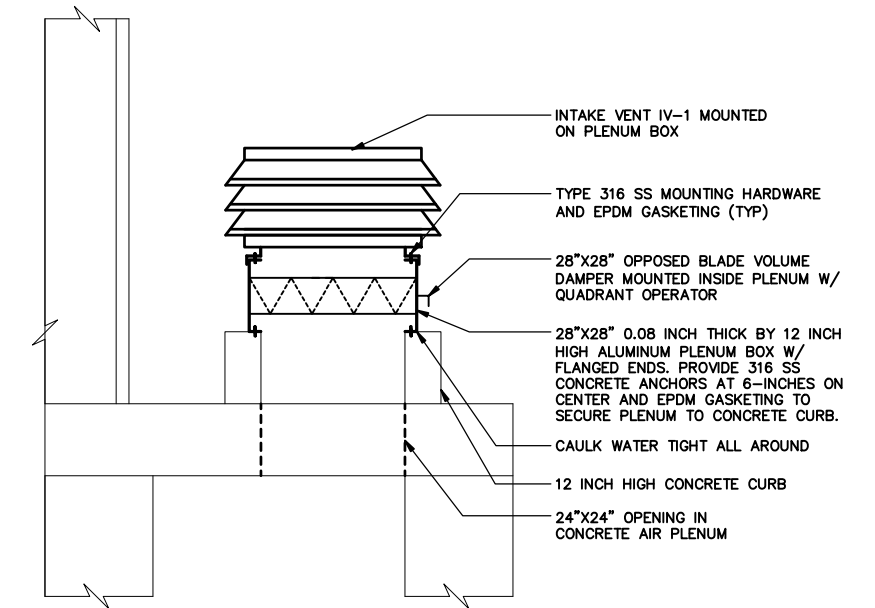

SECTION A H3 H3  
SCALE: 3/4" = 1'-0"

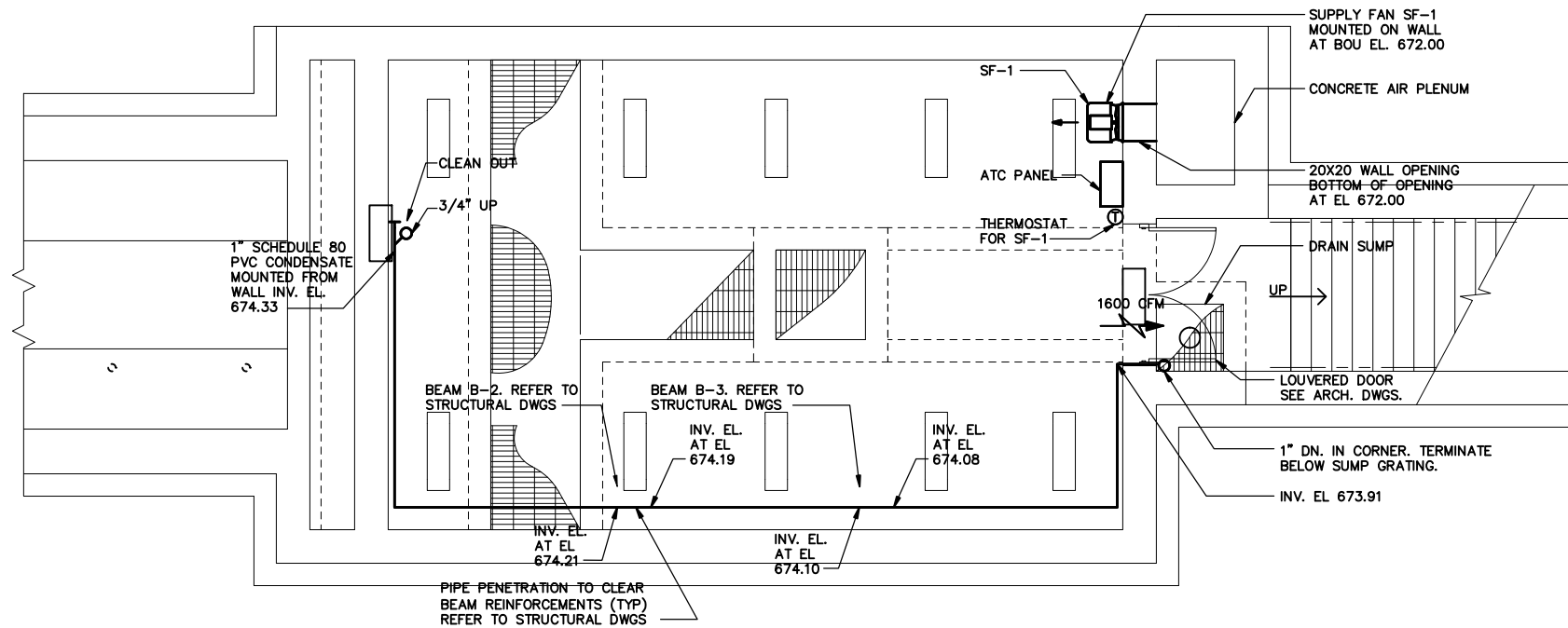

LOWER LEVEL PLAN AT EL 665.00

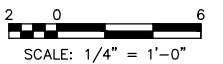

User: carlos Spec: PIRNIE STANDARD File: I:\CAD\PROJ\5324H503.DWG Scale: 1:1 Date: 12/03/2009 Time: 16:48 Layout: H03

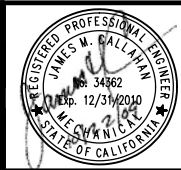

REVISIONS			
NO.	BY	DATE	REMARKS

DES SC  
DWN SC  
CKD VV

COVINA IRRIGATING COMPANY  
GLEN DORA, CALIFORNIA  
**UV/CHLORAMINES FOR TEMPLE WTP**

TEMPLE WATER TREATMENT PLANT  
**UV FACILITY**  
**UPPER AND LOWER LEVEL PLAN**  
SCALE: 1/4" = 1'-0"

COPYRIGHT © 2009  
MALCOLM PIRNIE, INC.  
DATE DECEMBER 2009  
H SHEET 3 OF 3  
CAD REF. NO. 5324H503

User: c:\p\pr\std\standard File: \CAD\PROJ\5324002 Covina\ELC\5324A676.DWG Scale: 1:1 Date: 12/03/2009 Time: 16:27 Layout: SE-1

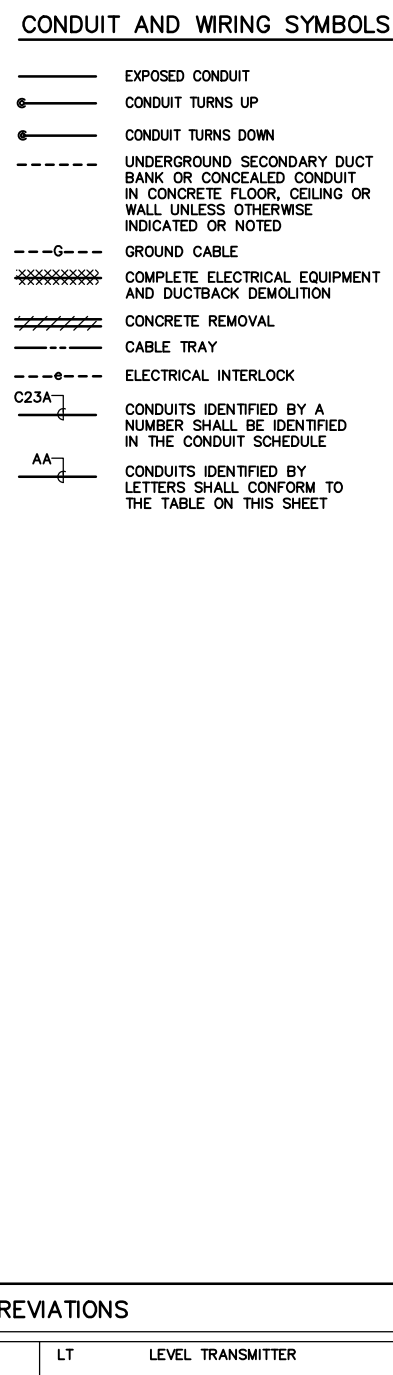
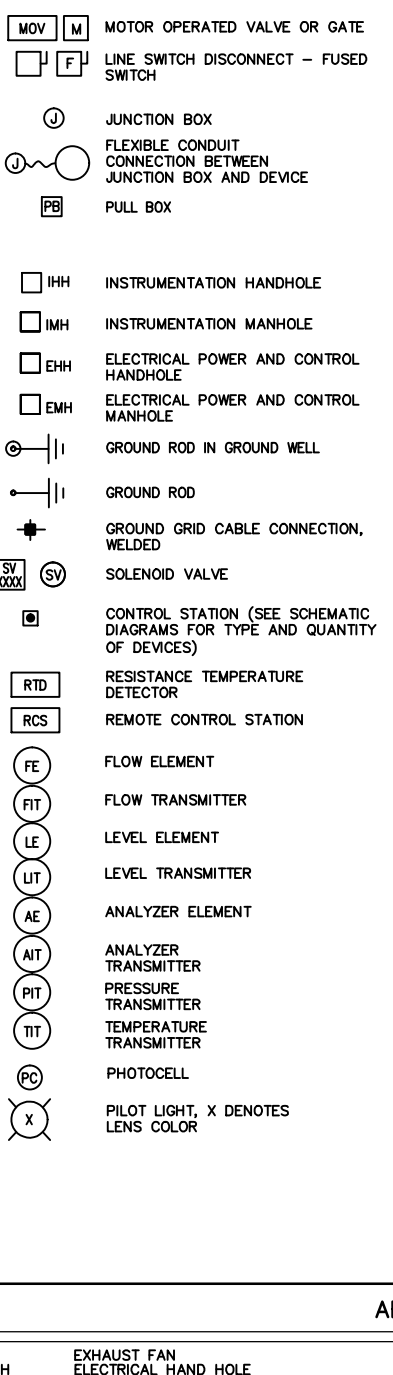
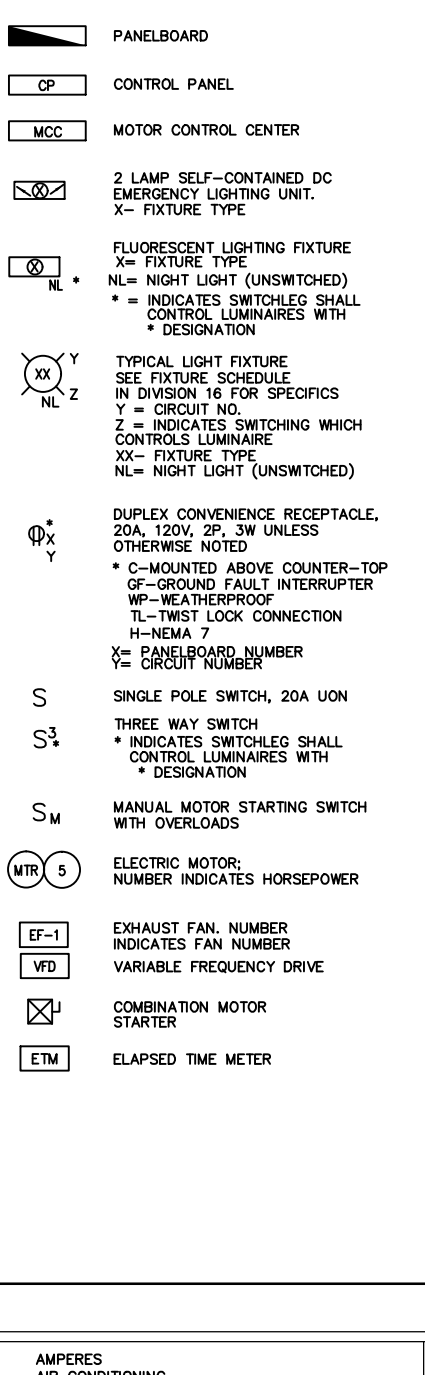
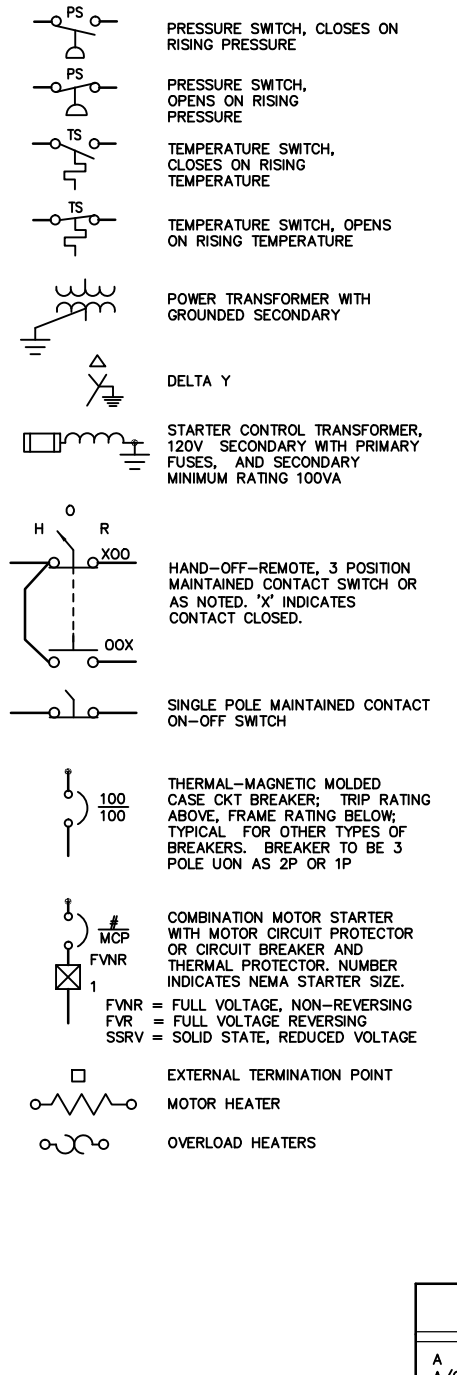
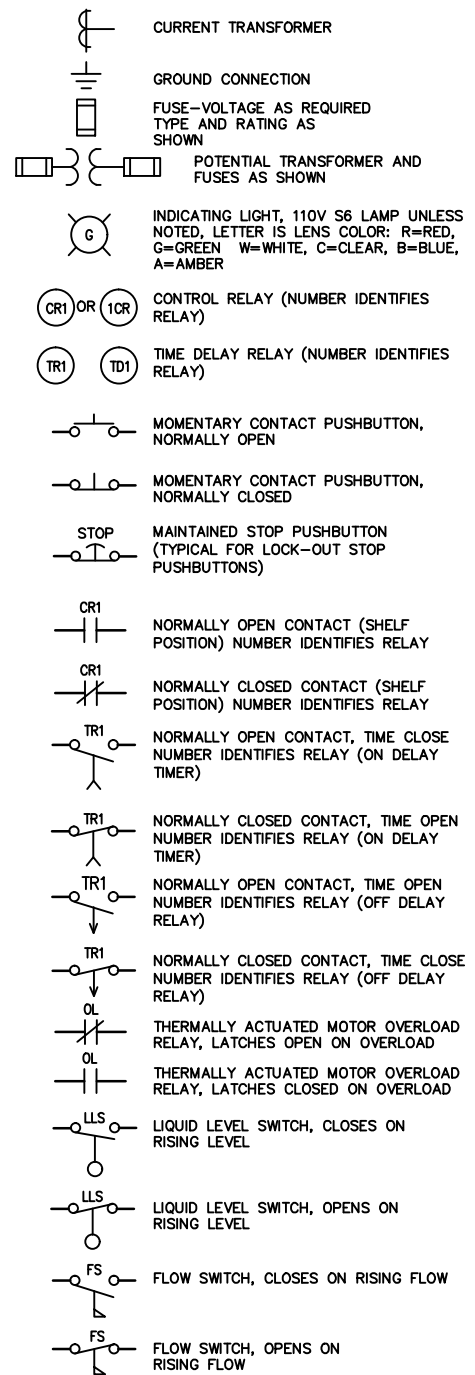

AA	2-#14, 1-#14 GND, 3/4"	EA	2-#6, 1-#6 GND, 3/4"
AB	3-#14, 1-#14 GND, 3/4"	EB	3-#6, 1-#6 GND, 3/4"
AC	4-#14, 1-#14 GND, 3/4"	EC	4-#6, 1-#6 GND, 1"
AD	5-#14, 1-#14 GND, 3/4"	ED	5-#6, 1-#6 GND, 1"
AE	6-#14, 1-#14 GND, 3/4"	EE	6-#6, 1-#6 GND, 1-1/2"
AF	7-#14, 1-#14 GND, 3/4"	EF	7-#6, 1-#6 GND, 1-1/2"
AG	8-#14, 1-#14 GND, 3/4"	EG	8-#6, 1-#6 GND, 1-1/2"
AH	9-#14, 1-#14 GND, 3/4"	EH	9-#6, 1-#6 GND, 1-1/2"
AJ	10-#14, 1-#14 GND, 3/4"	EJ	10-#6, 1-#6 GND, 1-1/2"
AK	12-#14, 1-#14 GND, 3/4"	FA	1-#16 STP, 3/4"
AL	14-#14, 1-#14 GND, 3/4"	FB	2-#16 STP, 1"
AM	22-#14, 1-#14 GND, 1"	FC	3-#16 STP, 1"
AN	36-#14, 3-#14 GND, 1"	FD	4-#16 STP, 1"
BA	2-#12, 1-#12 GND, 3/4"	FE	5-#16 STP, 1-1/2"
BB	3-#12, 1-#12 GND, 3/4"	FF	6-#16 STP, 1-1/2"
BC	4-#12, 1-#12 GND, 3/4"	FG	7-#16 STP, 1-1/2"
BD	5-#12, 1-#12 GND, 3/4"	FH	8-#16 STP, 2"
BE	6-#12, 1-#12 GND, 3/4"	FJ	9-#16 STP, 2"
BF	7-#12, 1-#12 GND, 3/4"	FK	10-#16 STP, 2"
BG	8-#12, 1-#12 GND, 3/4"	GA	1-#16 STT, 3/4"
BH	9-#12, 1-#12 GND, 3/4"	GB	2-#16 STT, 3/4"
BJ	10-#12, 1-#12 GND, 3/4"	GC	3-#16 STT, 1"
CA	2-#10, 1-#10 GND, 3/4"	GD	4-#16 STT, 1-1/2"
CB	3-#10, 1-#10 GND, 3/4"	GE	5-#16 STT, 1-1/2"
CC	4-#10, 1-#10 GND, 3/4"	GF	6-#16 STT, 1-1/2"
CD	5-#10, 1-#10 GND, 3/4"	GG	7-#16 STT, 1-1/2"
CE	6-#10, 2-#10 GND, 3/4"	GH	8-#16 STT, 2"
CF	7-#10, 1-#10 GND, 3/4"	GJ	9-#16 STT, 2"
CG	8-#10, 4-#10 GND, 1"	GK	10-#16 STT, 2"
CH	9-#10, 3-#10 GND, 1"	HA	MANF CABLE(S), 3/4"
CJ	10-#10, 1-#10 GND, 1"	HB	MANF CABLE(S), 1"
CK	15-#10, 1-#10 GND, 1"	HC	MANF CABLE(S), 1-1/2"
CL	20-#10, 1-#10 GND, 1-1/2"	HD	MANF CABLE(S), 2"
CM	12-#10, 6-#10 GND, 1"	JA	1-PLC REMOTE I/O CABLE, 1"
DA	2-#8, 1-#8 GND, 3/4"	JB	2-PLC REMOTE I/O CABLES, 1"
DB	3-#8, 1-#8 GND, 3/4"	KA	3/4" C WITH PULL STRING
DC	4-#8, 1-#8 GND, 1"	KB	1" C WITH PULLSTRING
DD	5-#8, 1-#8 GND, 1"	KC	1-1/2" C WITH PULLSTRING
DE	6-#8, 1-#8 GND, 1"	KD	2" C WITH PULLSTRING
DF	7-#8, 1-#8 GND, 1"	LA	1-MODBUS PLUS CABLE, 3/4" C
DG	8-#8, 1-#8 GND, 1-1/2"	LB	2-MODBUS PLUS CABLES, 3/4" C
DH	9-#8, 1-#8 GND, 1-1/2"	MA	1-ETHERNET CABLE, 2" C
DJ	10-#8, 1-#8 GND, 1-1/2"	MB	2-ETHERNET CABLES, 2" C

### ABBREVIATIONS

A	AMPERES	EF	EXHAUST FAN	LT	LEVEL TRANSMITTER	SES	SERVICE ENTRANCE SECTION
A/C	AIR CONDITIONING	EHH	ELECTRICAL HAND HOLE	MA	MILLIAMPERE	SPEC	SPECIFICATION
AC	ALTERNATING CURRENT	EP	EXPLOSION PROOF	MAX	MAXIMUM	SS	STAINLESS STEEL
AFF	ABOVE FINISHED FLOOR	ETM	ELAPSED TIME METER	MCC	MOTOR CONTROL CENTER	STP	SHIELDED TWISTED PAIR
APPROX	APPROXIMATELY	EXIST	EXISTING	MCM or KCMIL	THOUSAND CIRCULAR MILS	SV	SOLENOID VALVE
ATS	AUTO TRANSFER SWITCH	FE	FLOW ELEMENT	MCP	MOTOR CIRCUIT PROTECTOR	SW	SWITCH
AUX	AUXILIARY	FE	FLOW ELEMENT	MFR	MANUFACTURER	SWBD	SWITCHBOARD
AUTO	AUTOMATIC	FIT	FLOW INDICATING TRANSMITTER	MIN	MINIMUM	SWGR	SWITCHGEAR
AWG	AMERICAN WIRE GAUGE	FS	FLOW SWITCH	MOV	MOTOR OPERATED VALVE OR GATE	TD	TIME DELAY RELAY
BKR	BREAKER	FT	FEET OR FOOT	MTR	MOTOR	TEMP	TEMPERATURE
BLDG	BUILDING	GFI	GROUND FAULT INTERRUPTOR	N/A	NOT APPLICABLE	TS	TEMPERATURE SWITCH
CB	CIRCUIT BREAKER	GND	GROUND	NEC	NATIONAL ELECTRICAL CODE	TYP	TYPICAL
CKT	CIRCUIT	HOA	HAND/OFF/AUTO	NUU	NUMBER NOT USED	UPS	UNINTERRUPTIBLE POWER SUPPLY
CO	CONDUIT ONLY	HZ	HERTZ	NO, or #	NUMBER	V	VOLTS
CNTRL	CONTROL	IHH	INSTRUMENTATION HAND HOLE	NTS	NOT TO SCALE	VAC	VOLTS ALTERNATING CURRENT
CPT	CONTROL POWER TRANSFORMER	IN OR "	INCHES OR INCH	OL	OVERLOAD RELAY	VDC	VOLT DIRECT CURRENT
CU	COPPER	JB OR J	JUNCTION BOX, CONDULET, FITTING AS REQUIRED BY NEC, UNLESS NOTED OTHERWISE	PB	PULLBOX	VFD	VARIABLE FREQUENCY DRIVE
DC	DIRECT CURRENT	KAIC	THOUSAND AMPERE INTERRUPTING CAPACITY (SYMMETRICAL)	PS	PRESSURE SWITCH	W	WATTS
DIA	DIAMETER	KVA	KILOVOLT AMPERES	PVC	POLYVINYL CHLORIDE	WP	WEATHERPROOF
DISC	DISCONNECT	KW	KILOWATTS	RGS	RIGID GALVANIZED STEEL	XFMR	TRANSFORMER
DPL	DISTRIBUTION PANEL LOW	LCP	LOCAL CONTROL PANEL	RS	RIGID STEEL	1ø	SINGLE PHASE
DPH	DISTRIBUTION PANEL HIGH	LOS	LOCK-OUT STOP	SCE	SOUTHERN CALIFORNIA EDISON	3ø	3 PHASE
DWG	DRAWING					3W	THREE WIRE
						4W	FOUR WIRE

REVISIONS			
NO.	BY	DATE	REMARKS

DES BY \_\_\_\_\_  
 DWN BY \_\_\_\_\_  
 CRD JAS

**COVINA IRRIGATING COMPANY  
 GLENDORA, CALIFORNIA**

## UV/CHLORAMINES FOR TEMPLE WTP

**TEMPLE WATER TREATMENT PLANT**

# ELECTRICAL LEGEND AND ABBREVIATIONS

NO SCALE

COPYRIGHT © 2009  
 MALCOLM PIRNIE, INC.  
 DATE DECEMBER 2009  
 GE SHEET 1 OF 2  
 CAD REF. NO. 5324A676



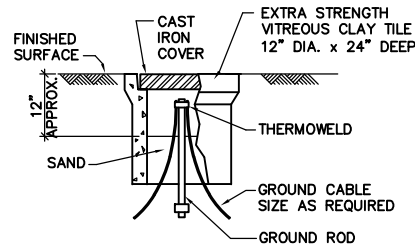

TYPICAL GROUND WELL

DETAIL 1  
- GE2

NOT TO SCALE

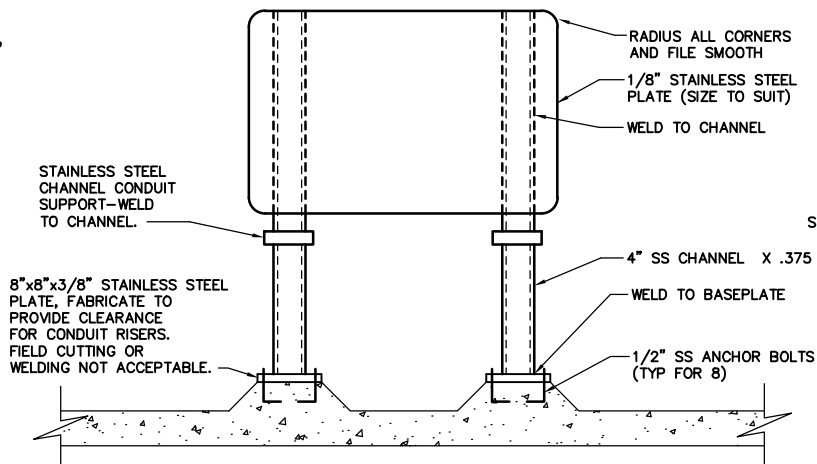

TYPICAL DISCONNECT SWITCH/CONTROL PANEL MOUNTING ELEVATION

DETAIL 2  
- GE2

NOT TO SCALE

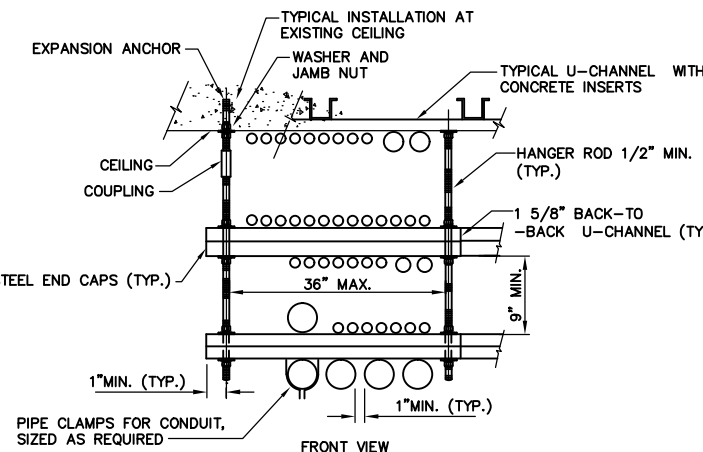

TYPICAL SUSPENDED CONDUIT AND/OR TRAY RACK

DETAIL 3  
- GE2

NOT TO SCALE

NOTES:

1. MATERIALS AND HARDWARE SHALL CONFORM TO THE REQUIREMENTS OF DIVISION 16.

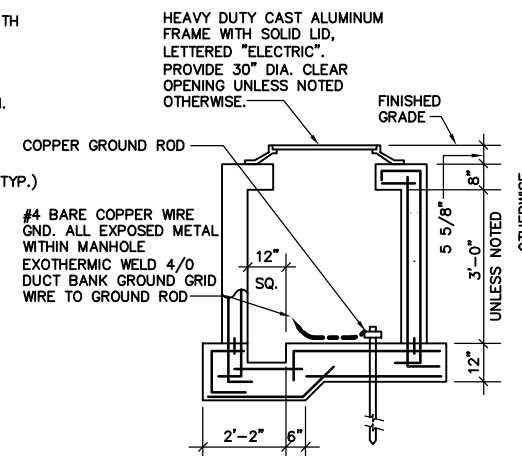

SECTION

NOTES:

1. ALL HANDHOLES WILL BE CONSTRUCTED TO MEET H-20-44 LOADING CRITERIA. CONTRACTOR SHALL DESIGN AND SUBMIT DESIGN CALCULATIONS AND DETAILED DRAWINGS FOR CAST-IN-PLACE MANHOLES. IF PRECAST CONCRETE PRODUCTS ARE USED, CERTIFICATION CONCERNING THE LOADING CAPACITY SHALL BE SUBMITTED. ALL DESIGN CALCULATIONS SHALL BE SEALED BY A REGISTERED PROFESSIONAL STRUCTURAL ENGINEER, LICENSED TO PRACTICE IN THE STATE OF CALIFORNIA.

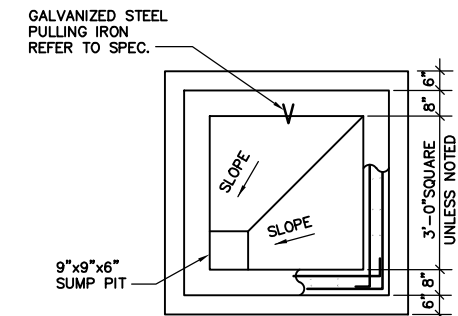

PLAN

30\"/>

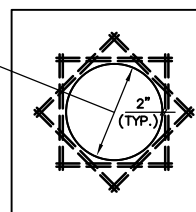

ROOF PLAN

2. BELOW GRADE HAND HOLES SHALL BE SIZED MINIMUM 3'X3'X3', BUT IN NO INSTANCE LESS THAN 125% OF THE DIMENSIONS REQUIRED BY THE NEC. ALL BELOW GRADE HANDHOLES SHALL BE SUBMITTED FOR APPROVAL BEFORE INSTALLATION.

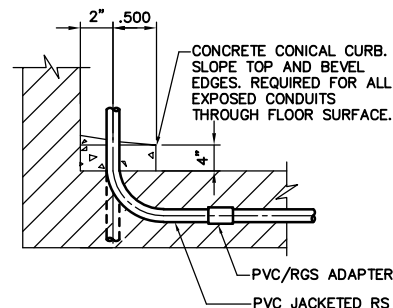

TYPICAL CONDUIT CURB

DETAIL 5  
- GE2

NOT TO SCALE

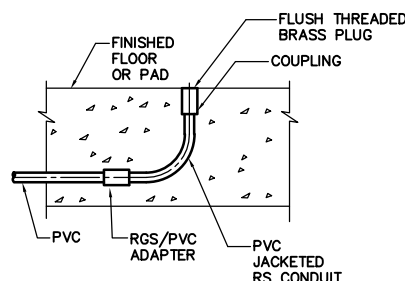

TYPICAL SPARE CONDUIT TERMINATION

DETAIL 6  
- GE2

NOT TO SCALE

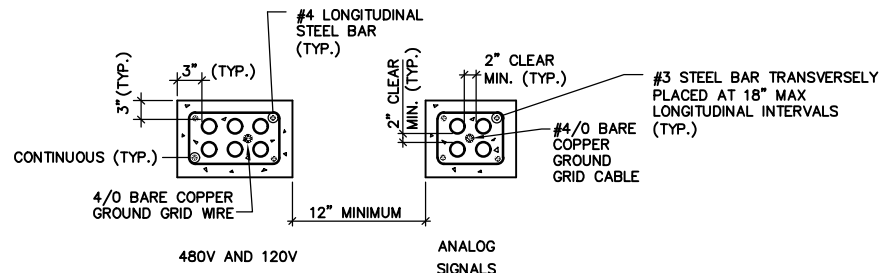

TYPICAL UNDERGROUND DUCTBANKS

DETAIL 7  
- GE2

NOT TO SCALE

NOTES:

1. MAINTAIN 12\"/>

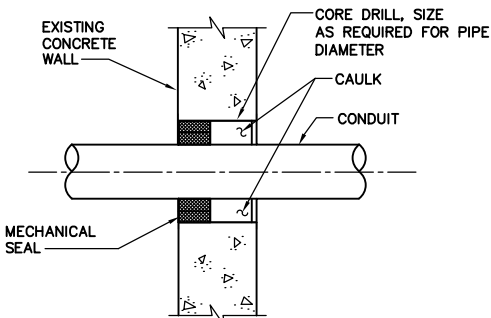

TYPICAL WALL SLEEVE

DETAIL 8  
- GE2

NOT TO SCALE

NOTES:

1. MECHANICAL SEAL W/ S.S. BOLTS (ONE SET FOR PIPE)

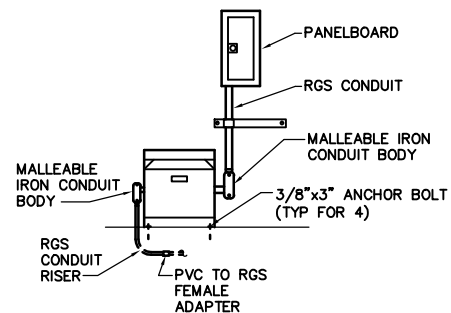

TYPICAL FLOOR MOUNTED TRANSFORMER

DETAIL 9  
- GE2

NOT TO SCALE

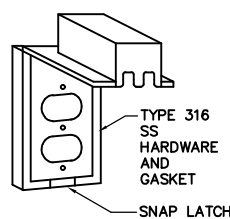

NON-METALLIC OUTDOOR WEATHERPROOF RECEPTACLE COVER (SEE NOTE 3)

DETAIL 10  
- GE2

NOT TO SCALE

NOTES:

1. FLAT WASHERS AND LOCK WASHERS SHALL BE USED WITH ALL FASTENERS.
2. ALL HARDWARE 3/16\"/>
3. COVER SHALL BE TAYMAC OR APPROVED EQUAL AND SHALL BE UL LISTED.

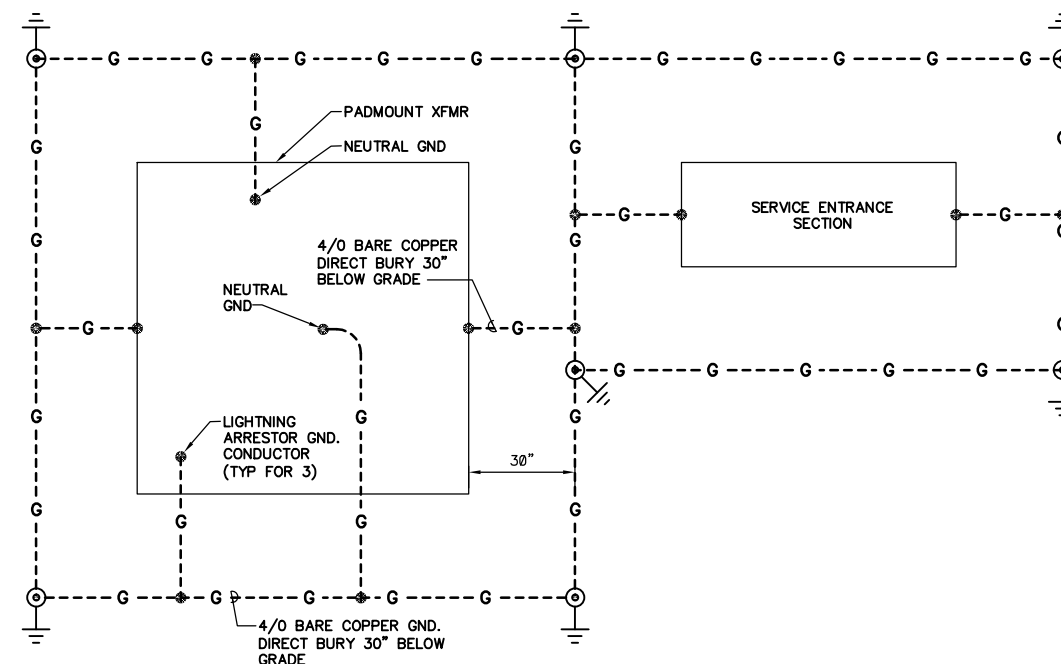

PAD MOUNTED TRANSFORMER/SES GROUNDING GRID INSTALLATION

DETAIL 11  
- GE2

NOT TO SCALE

REVISIONS			
NO.	BY	DATE	REMARKS

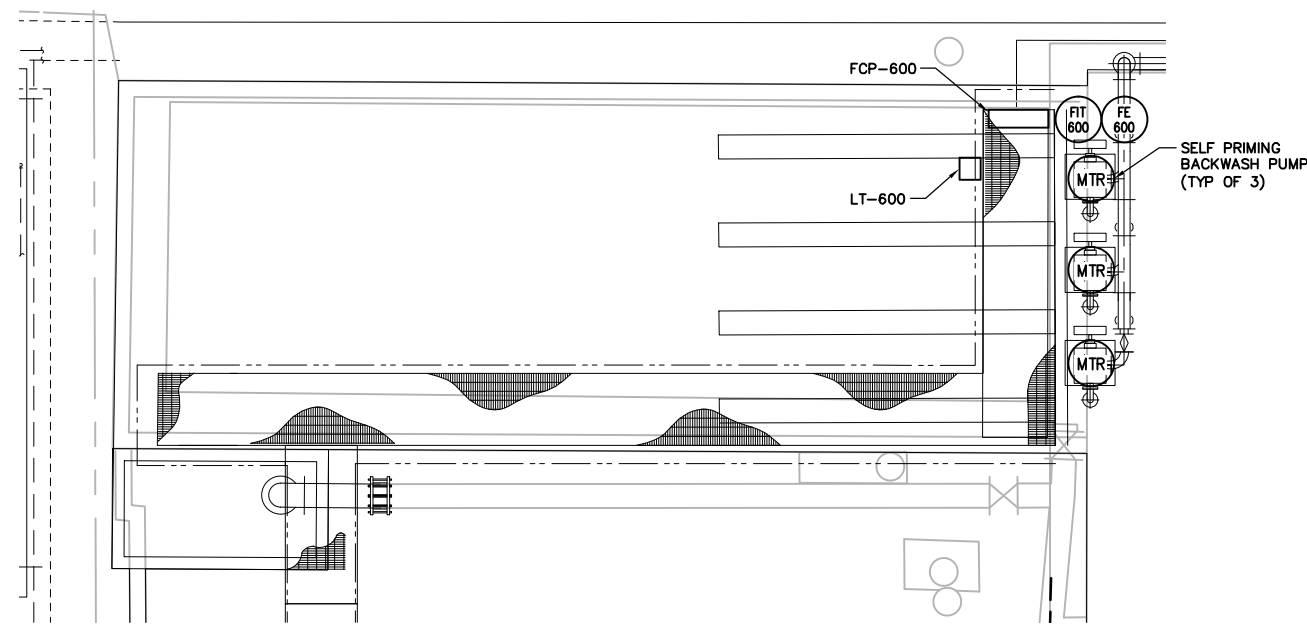
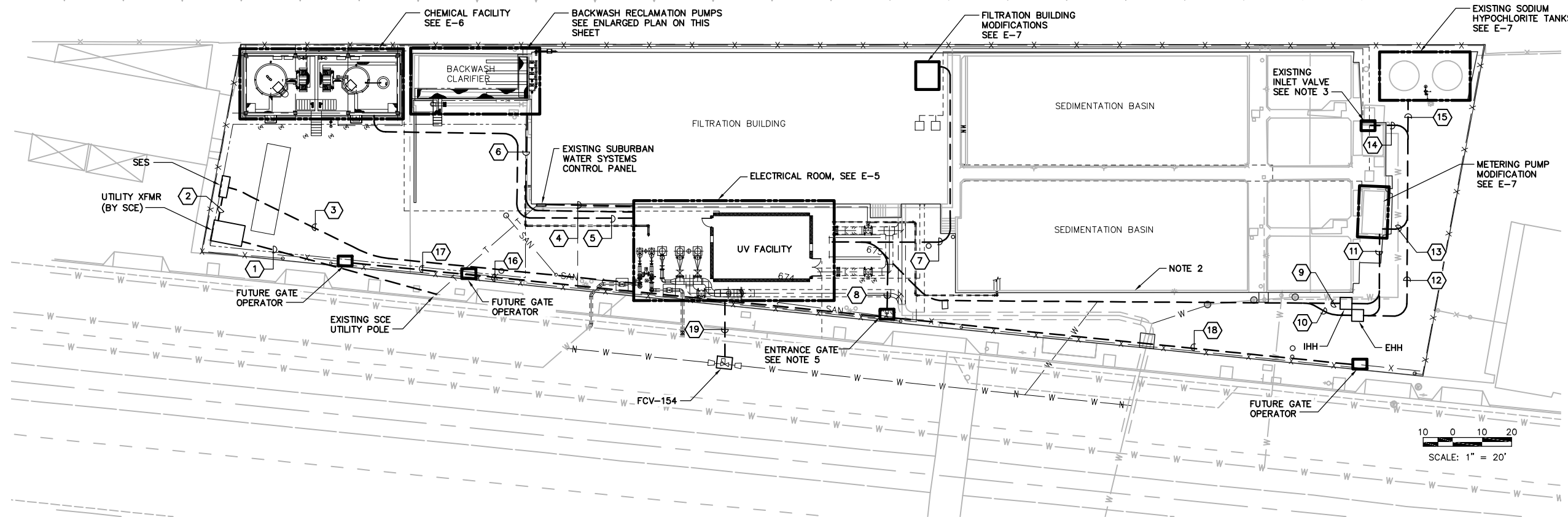

BACKWASH CLARIFIER EQUIPMENT LAYOUT

SCALE: 1/4" = 1'-0"

#	CONTENTS
1	C001
2	C002, C003, C004, C005
3	C006, C007, C008, C009
4	C059, C184, C185
5	C068, C069, C070, C071, C072, C073, C074, C075, C076, C078, C079, C080, C081, C082, C103, C104, C107, C108, C109, C112, C113, C114, C115, C118, C119, C120, C121, C122, C127, C128, C129
6	C017, C083, C116, C117, C123, C137
7	C013, C041, C085, C105, C106, C111, C163, C164, C165, C166, C167
8	C110, C148, C149
9	C143, C159, C160, C161, C162
10	C039, C142, C155, C156, C157, C158
11	C142, C143
12	C039
13	C124, C125, C126, C152, C153, C154
14	C039, C102, C130, C131

#	CONTENTS
15	C102, C124, C125, C126, C130, C131, C152, C153, C154
16	C177, C178, C179, C180
17	C179, C180
18	C181, C182
19	C183

NOTES:

- UTILITY TRANSFORMER AND SERVICE ENTRANCE SECTION INSTALLATION TO CONFORM TO ALL REQUIREMENTS OF SCE ELECTRIC COMPANY.
- ALL EXISTING CONDUITS MOUNTED ON THE SEDIMENTATION BASIN WALL SHALL BE REMOVED ALONG WITH THEIR ASSOCIATED CONDUCTORS. FURNISH AND INSTALL CONDUIT AND CONDUCTOR AS INDICATED UNDER THIS CONTRACT.
- CONTRACTOR SHALL DISCONNECT AND REMOVE EXISTING POWER CONDUCTORS FOR EXISTING INLET VALVE FCV-101 AND ABANDON CONDUIT IN PLACE. FURNISH AND INSTALL CONDUIT AND CONDUCTOR AS INDICATED UNDER THIS CONTRACT.
- WHERE THE WORK OF THE CONTRACTOR TIES IN WITH EXISTING INSTALLATIONS, THE CONTRACTOR SHALL FIELD VERIFY EXISTING LOADS AND SHALL FURNISH AND INSTALL CONDUIT AND CONDUCTOR TO REFEED ALL EXISTING EQUIPMENT. ADVANCE NOTICE WILL BE REQUIRED BEFORE ANY EQUIPMENT IS REMOVED FROM SERVICE. NOTIFY OWNER, IN WRITING, OF THEIR INTENTION TO DO SUCH WORK, PROVIDING FULL DETAILS.
- FURNISH AND INSTALL A 12" X 12" X 6" NEMA 3R PULLBOX FOR FUTURE GATE OPERATOR CONDUIT CONNECTION.

User: Young Spec:Pirnie\_STANDARD File: \\Orange\CADD\CADD\PROJ\5324402\_Covina\ELEC\53244678.DWG Scale: 1:1 Date: 07/01/2009 Time: 11:13 Layout: E-1



REVISIONS			
NO.	BY	DATE	REMARKS

DES	BY
DWN	CW
CRD	JAS

COVINA IRRIGATING COMPANY  
 GLENDORA, CALIFORNIA  
**UV/CHLORAMINES FOR TEMPLE WTP**

TEMPLE WATER TREATMENT PLANT  
**SITE CONDUIT PLAN**

SCALE AS SHOWN

COPYRIGHT © 2009  
 MALCOLM PIRNIE, INC.  
 DATE DECEMBER 2009  
 E SHEET 1 OF 14  
 CAD REF. NO. 5324A678

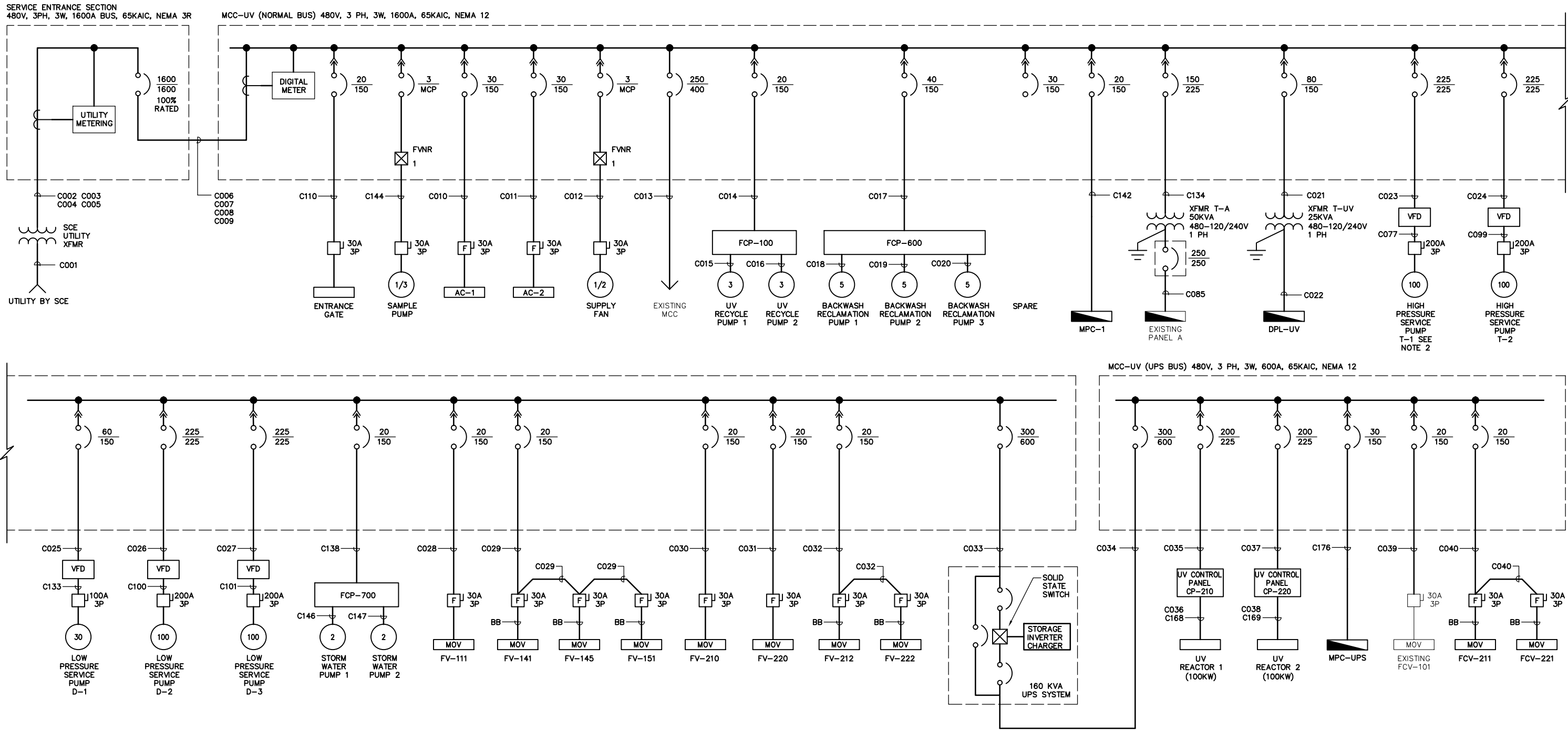

MCC-UV ONE LINE DIAGRAM

- NOTES:**
- LIGHTER LINES INDICATE EXISTING ELEMENTS. HEAVIER LINES INDICATE WORK TO BE DONE UNDER THIS CONTRACT.
  - PUMP T-1, VFD AND ASSOCIATED CABLE AND CONDUIT ARE A PART OF BID ITEM 5-SUBURBAN WATER SYSTEMS FACILITIES IMPROVEMENTS.

User: arivos Spec: PIRNIE\_STANDARD File: I:\CAD\PROJ\5324602 Covina\ELEC\53244679.DWG Scale: 1:1 Date: 12/03/2009 Time: 16:36 Layout: E-2



REVISIONS			
NO.	BY	DATE	REMARKS

DES BY  
DWN BY  
CRD JAS

COVINA IRRIGATING COMPANY  
GLENORA, CALIFORNIA  
**UV/CHLORAMINES FOR TEMPLE WTP**

TEMPLE WATER TREATMENT PLANT  
**ONE LINE DIAGRAM**  
NO SCALE

COPYRIGHT © 2009  
MALCOLM PIRNIE, INC.  
DATE DECEMBER 2009  
E SHEET 2 OF 14  
CAD REF. NO. 5324A679



MINI POWER CENTER - 5KVA TRANSFORMER, 480V-240/120V, 1Ø									
PANEL MPC - 1 SCHEDULE LOCATION METERING PUMP ENCLOSURE FED FROM MCC-UV									
240/120 VOLT SINGLE PHASE THREE WIRE 20 AMP BUS 20 AMP MAIN CKT BKR 10 KAIC									
CKT NO.	EQUIPMENT	A	LOAD KVA	A	B	LOAD KVA	A	EQUIPMENT	CKT NO.
1	FIT-315	20	0.1	[Diagram]		0.2	20	LIT-301, LIT-302	2
3	FCP-310	20	0.3	[Diagram]		0.3	20	FCP-320	4
5	RIO-B	20	0.5	[Diagram]		-	20	SPARE	6
7	SPARE	20	-	[Diagram]		-	20	SPARE	8
9	SPARE	20	-	[Diagram]		-	20	SPARE	10
11	SPARE	20	-	[Diagram]		-	20	SPARE	12
KVA SUB TOTAL			0.9	KVA TOTAL		1.4	0.5	KVA SUB TOTAL	

MINI POWER CENTER - 15KVA TRANSFORMER, 480V-208/120V, 3Ø										
PANEL MPC - UPS SCHEDULE LOCATION UV ELECTRICAL ROOM FED FROM MCC-UV										
208/120 VOLT THREE PHASE FOUR WIRE 100 AMP BUS 40 AMP MAIN CKT BKR 10 KAIC										
CKT NO.	EQUIPMENT	A	LOAD KVA	A	B	C	LOAD KVA	A	EQUIPMENT	CKT NO.
1	MASTER CONTROL PANEL	20	0.5	[Diagram]			0.4	20	WORKSTATION RECEPTACLES	2
3	OIT-210	20	0.3	[Diagram]			0.1	20	AIT-202	4
5	OIT-220	20	0.3	[Diagram]			0.2	20	FIT-209, FIT-219	6
7	SPARE	20	-	[Diagram]			-	20	SPARE	8
9	SPARE	20	-	[Diagram]			-	20	SPARE	10
11	SPARE	20	-	[Diagram]			-	20	SPARE	12
KVA SUB TOTAL			1.0	KVA TOTAL			1.7	0.7	KVA SUB TOTAL	

PANEL DPL-UV SCHEDULE LOCATION UV FACILITY ELECTRICAL ROOM FED FROM XFMR T-UV									
120/240 VOLT SINGLE PHASE THREE WIRE 100 AMP BUS 100 AMP MAIN CKT BKR									
CKT NO.	EQUIPMENT	A	LOAD KVA	A	B	LOAD KVA	A	EQUIPMENT	CKT NO.
1	LOW LEVEL RELAY ENCLOSURE	20	0.1	[Diagram]		0.5	20	EXIST WATER SYSTEMS CONTROL PANEL	2
3	FCP-400	20	0.3	[Diagram]		0.3	20	FCP-500	4
5	FCP-401	20	0.3	[Diagram]		0.3	20	FCP-501	6
7	AIT-113, AIT-201	20	0.2	[Diagram]		1.2	20	CANOPY LIGHTING	8
9	MASTER CONTROL PANEL	20	1.0	[Diagram]		0.2	20	CANOPY RECEPTACLES	10
11	FCP-330	20	0.3	[Diagram]		1.5	20	ELECTRICAL ROOM LIGHTING	12
13	FCP-340	20	0.3	[Diagram]		0.6	20	ELECTRICAL ROOM RECEPTACLES	14
15	ATC-1	20	0.2	[Diagram]		2.3	20	CHEMICAL FACILITY LIGHTING	16
17	UV FACILITY LIGHTS	20	1.2	[Diagram]		0.8	20	CHEMICAL FACILITY RECEPTACLES	18
19	EXTERIOR LIGHTING	20	0.9	[Diagram]		0.1	20	FIT-415	20
21	UV FACILITY RECEPTACLES	20	0.4	[Diagram]		0.5	20	ENTRANCE GATE	22
23	FIT-600	20	0.1	[Diagram]		0.1	20	FIT-335	24
25	FIT-011	20	0.1	[Diagram]		0.3	20	FCP-101	26
27	FIT-152, FIT-142	20	0.2	[Diagram]		0.1	20	LIT-102	28
29	FIT-154	20	0.1	[Diagram]		-	20	SPARE	30
31	LT-600	20	0.2	[Diagram]		0.1	20	FIT-515	32
33	LIT-401	20	0.1	[Diagram]		1.0	20	MASTER CONTROL PANEL	34
35	LIT-501	20	0.1	[Diagram]		0.5	20	MASTER CONTROL PANEL	36
37	SPARE	20	-	[Diagram]		-	20	SPARE	38
39	-	-	-	[Diagram]		-	-	-	40
41	-	-	-	[Diagram]		-	-	-	42
KVA SUB TOTAL			6.1	KVA TOTAL		16.5	10.4	KVA SUB TOTAL	

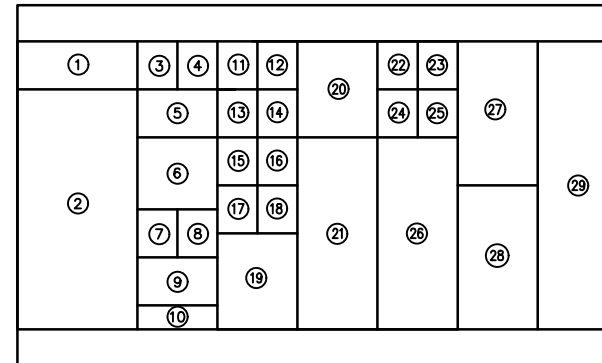

MCC-UV ELEVATION  
NOT TO SCALE

NO.	EQUIPMENT
1	DIGITAL METER
2	MAIN LUGS ONLY
3	AC-1
4	AC-2
5	SUPPLY FAN
6	EXISTING MCC FEEDER
7	FCP-100
8	FCP-600
9	SAMPLE PUMP
10	SPACE
11	ENTRANCE GATE
12	FCP-700
13	FV-111
14	FV-141, FV-145, FV-151
15	FV-210
16	FV-220
17	FV-212
18	MINI-POWER CENTER 1
19	TRANSFORMER T-UV
20	TRANSFORMER T-A
21	UPS FEEDER BREAKER
22	SPACE
23	MINI-POWER CENTER UPS
24	EXISTING FCV-101
25	FCV-211, FCV-221
26	UPS BUS MAIN BREAKER
27	UV POWER CENTER 1
28	UV POWER CENTER 2
29	SPACE

MCC-UV LOAD SUMMARY			
EQUIPMENT	HP	CONNECTED AMPS @ 480V	OPERATING AMPS @ 480V
LOW PRESSURE SERVICE PUMP D-1		30	40
LOW PRESSURE SERVICE PUMP D-2		100	124
LOW PRESSURE SERVICE PUMP D-3		100	124
HIGH PRESSURE SERVICE PUMP T-1		100	124
HIGH PRESSURE SERVICE PUMP T-2		100	124
AC-1			18
AC-2			18
FCP-100 (UV RECYCLE PUMPS)		20	20
FCP-600 (BACKWASH PUMPS)		40	40
FCP-700 (STORM WATER PUMPS)		7	7
SUPPLY FAN		5	8
UV REACTOR 1	(100 kW)	150	150
UV REACTOR 2	(100 kW)	150	0
EXISTING FCV-101		3	3
FV-111		3	3
FV-141		3	3
FV-145		3	3
FV-151		3	3
FV-210		3	3
FCV-211		3	3
FV-212		3	3
FV-220		3	3
FCV-221		3	3
FV-222		3	3
SAMPLE PUMP		2	2
MINI-POWER CENTER 1		4	4
ENTRANCE GATE		2	2
TRANSFORMER T-UV		30	30
TRANSFORMER T-A		92	92
EXISTING MCC		226	226
MINI-POWER CENTER UPS		3	3
25% LARGEST MOTOR			31
TOTAL		1339	1220

XREFS: \\XREF\_5324-TBLK.dwg IMAGES:None  
 User: arivas Spec:PIRNIE\_STANDARD File: \\ACAD\PROJ\5324002 Covina\ELEC\5324A680.DWG Scale: 1:1 Date: 12/03/2009 Time: 16:36 Layout: E-3



REVISIONS			
NO.	BY	DATE	REMARKS

DES BY \_\_\_\_\_  
 DWN BY \_\_\_\_\_  
 CKD JAS

COVINA IRRIGATING COMPANY  
 GLENDORA, CALIFORNIA  
**UV/CHLORAMINES FOR TEMPLE WTP**

TEMPLE WATER TREATMENT PLANT  
**MCC-UV ELEVATION/LOAD SUMMARY  
 AND PANELBOARD SCHEDULE**  
 SCALE: AS SHOWN

COPYRIGHT © 2009  
 MALCOLM PIRNIE, INC.  
 DATE DECEMBER 2009  
 E SHEET 3 OF 14  
 CAD REF. NO. 5324A680

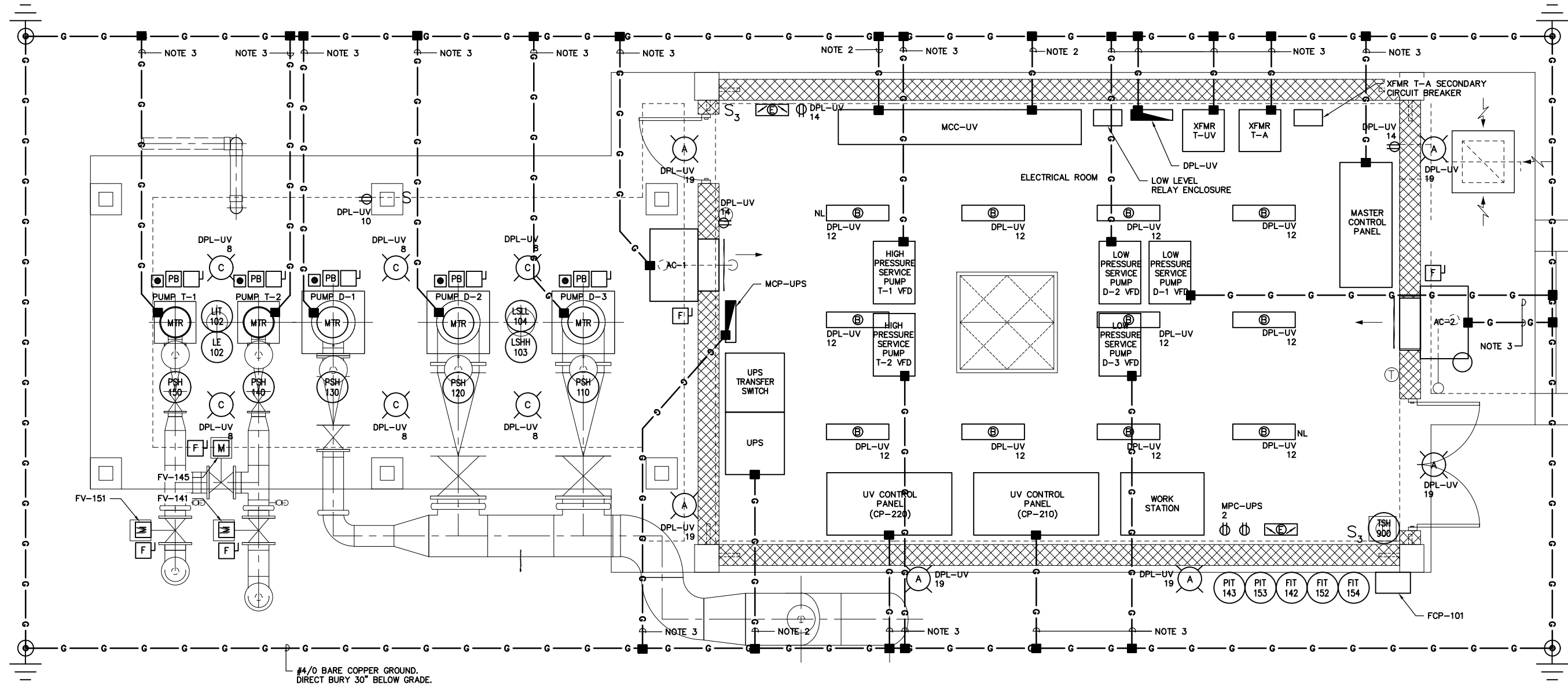

#4/0 BARE COPPER GROUND.  
DIRECT BURY 30" BELOW GRADE.

**NOTES:**

1. SEE BLOCK DIAGRAMS ON SHEETS E-8 AND E-9 FOR POWER AND CONTROL CONDUIT INTERCONNECTION.
2. #4/0 BARE COPPER GROUND.
3. #4 BARE COPPER GROUND.
4. ALL CONDUITS 1-1/2" AND LARGER SHALL BE ROUTED EXPOSED ABOVE OR BELOW THE ELECTRICAL ROOM FLOOR SLAB.
5. FOR LIGHT FIXTURES AND RECEPTACLES, THE CONTRACTOR SHALL FURNISH AND INSTALL 3/4" CONDUIT AND THE CORRECT NUMBER OF #12AWG CONDUCTORS FOR 20A CIRCUITS AND #10AWG CONDUCTORS FOR 30A CIRCUITS. DO NOT SHARE NEUTRALS. A MAXIMUM OF SIX CONDUCTORS SHALL BE INSTALLED IN A SINGLE CONDUIT.
6. PUMP T-1, VFD AND ASSOCIATED CABLE AND CONDUIT ARE A PART OF BID ITEM 5-SUBURBAN WATER SYSTEMS FACILITIES IMPROVEMENTS.

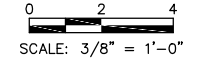

XREFS: \\VREF\MGP\UVF.dwg - VREF\SGPUV.dwg - VREF\3324-TBLK.dwg IMAGES: None  
 User: Young Spac: PIRNIE\_STANDARD File: \\Orange\CADD\CADD\PROJ\5324\02 Covina\ELEC\53244681.DWG Scale: 1:1 Date: 06/26/2009 Time: 12:58 Layout: E-4



REVISIONS			
NO.	BY	DATE	REMARKS

DES BY  
DWN BY  
CRD JAS

COVINA IRRIGATING COMPANY  
GLENORA, CALIFORNIA  
**UV/CHLORAMINES FOR TEMPLE WTP**

TEMPLE WATER TREATMENT PLANT  
**UV FACILITY**  
**UPPER LEVEL POWER PLAN**  
SCALE: 3/8"=1'-0"

COPYRIGHT © 2009  
MALCOLM PIRNIE, INC.  
DATE DECEMBER 2009  
E SHEET 4 OF 14  
CAD REF. NO. 5324A681

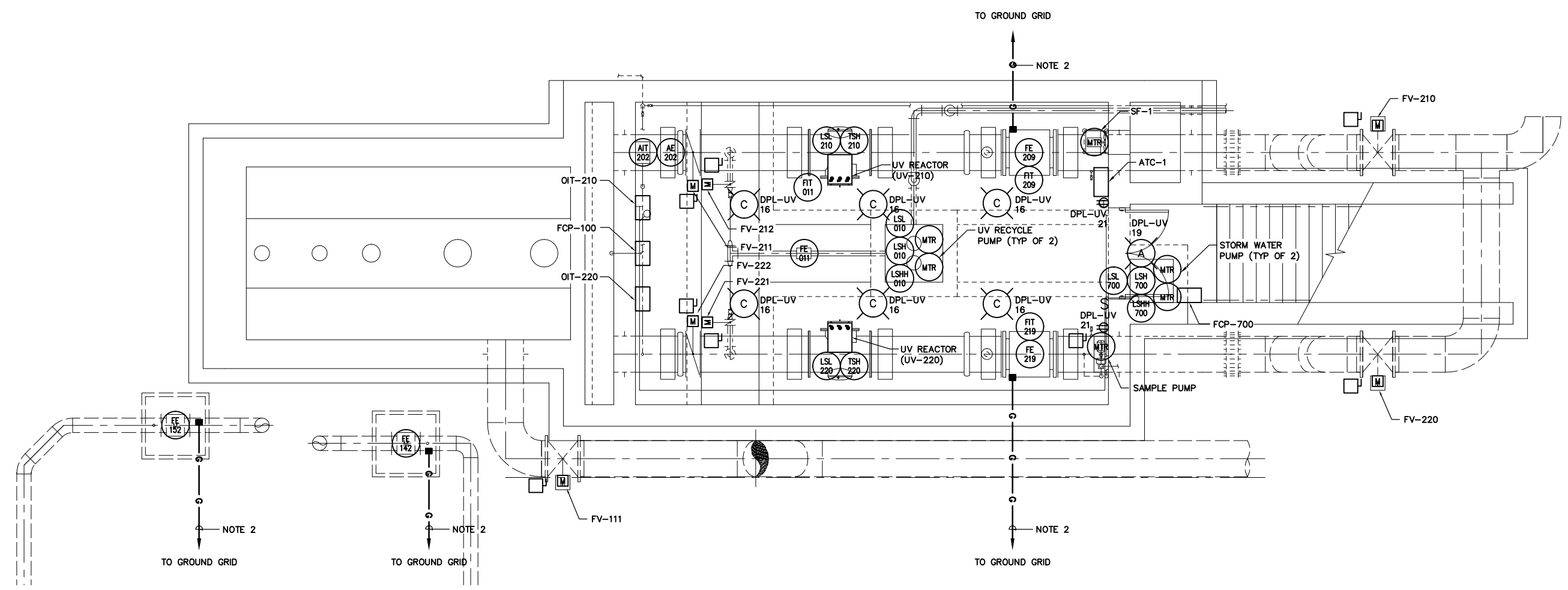
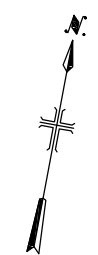

**NOTES:**

1. SEE BLOCK DIAGRAMS ON SHEETS E-8 AND E-9 FOR POWER AND CONTROL CONDUIT INTERCONNECTION.
2. #4 BARE COPPER GROUND.
3. ALL CONDUITS 1-1/2" AND LARGER SHALL BE ROUTED EXPOSED ABOVE OR BELOW THE ELECTRICAL ROOM FLOOR SLAB.
4. FOR LIGHT FIXTURES AND RECEPTACLES, THE CONTRACTOR SHALL FURNISH AND INSTALL 3/4" CONDUIT AND THE CORRECT NUMBER OF #12AWG CONDUCTORS FOR 20A CIRCUITS AND #10AWG CONDUCTORS FOR 30A CIRCUITS. DO NOT SHARE NEUTRALS. A MAXIMUM OF SIX CONDUCTORS SHALL BE INSTALLED IN A SINGLE CONDUIT.
5. FE 152, FIT 152 AND PIT 153 ARE PARTS OF BID ITEM 5-SUBURBAN WATER SYSTEMS FACILITIES IMPROVEMENTS.

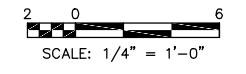

XREFS: \\VREF\MGP\UVF.dwg ... \VREF\SGPUV.dwg ... \VREF\5324-TBLK.dwg IMAGES: None  
 User: arivos Spec: PIRNIE\_STANDARD File: \\VACAD\PROJ\5324002 Covina\ELEC\5324A682.DWG Scale: 1:1 Date: 12/03/2009 Time: 16:35 Layout: E-5



REVISIONS			
NO.	BY	DATE	REMARKS

DES BY  
DWN BY  
CRD JAS

COVINA IRRIGATING COMPANY  
 GLENDORA, CALIFORNIA  
**UV/CHLORAMINES FOR TEMPLE WTP**

TEMPLE WATER TREATMENT PLANT  
**UV FACILITY**  
**LOWER LEVEL POWER PLAN**  
 SCALE: 1/4"=1'-0"

COPYRIGHT © 2009  
 MALCOLM PIRNIE, INC.  
 DATE DECEMBER 2009  
 E SHEET 5 OF 14  
 CAD REF. NO. 5324A682

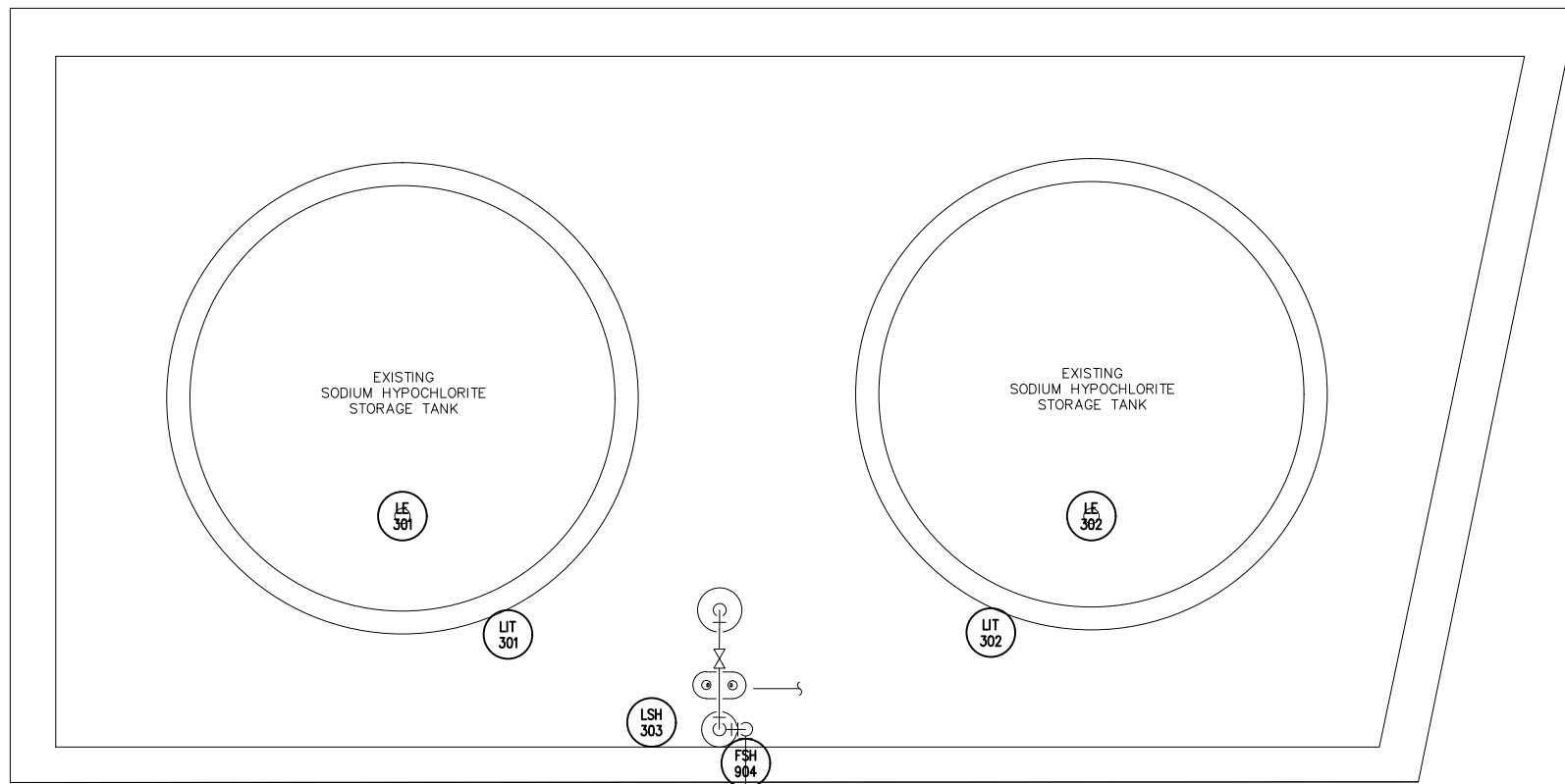

EXISTING SODIUM HYPOCHLORITE  
TANKS POWER PLAN  
SCALE: 1/2"=1'-0"

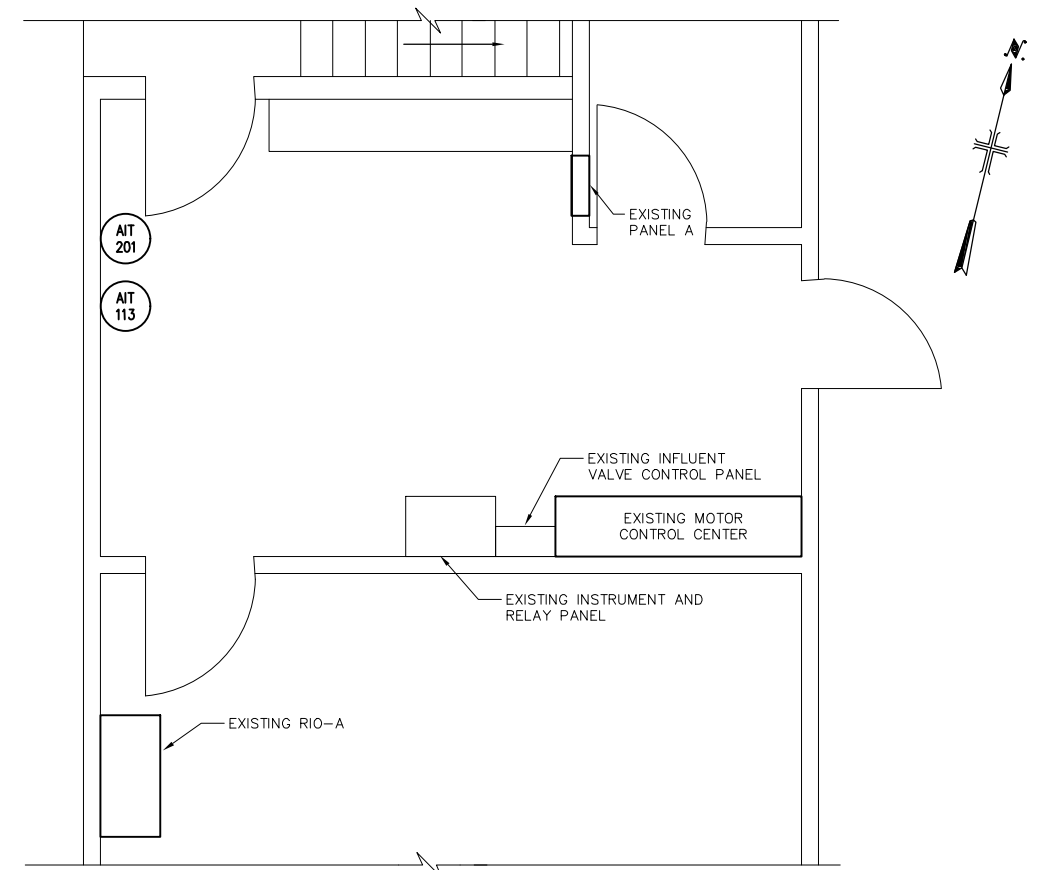

FILTRATION BUILDING OFFICE  
SCALE: 3/8"=1'-0"

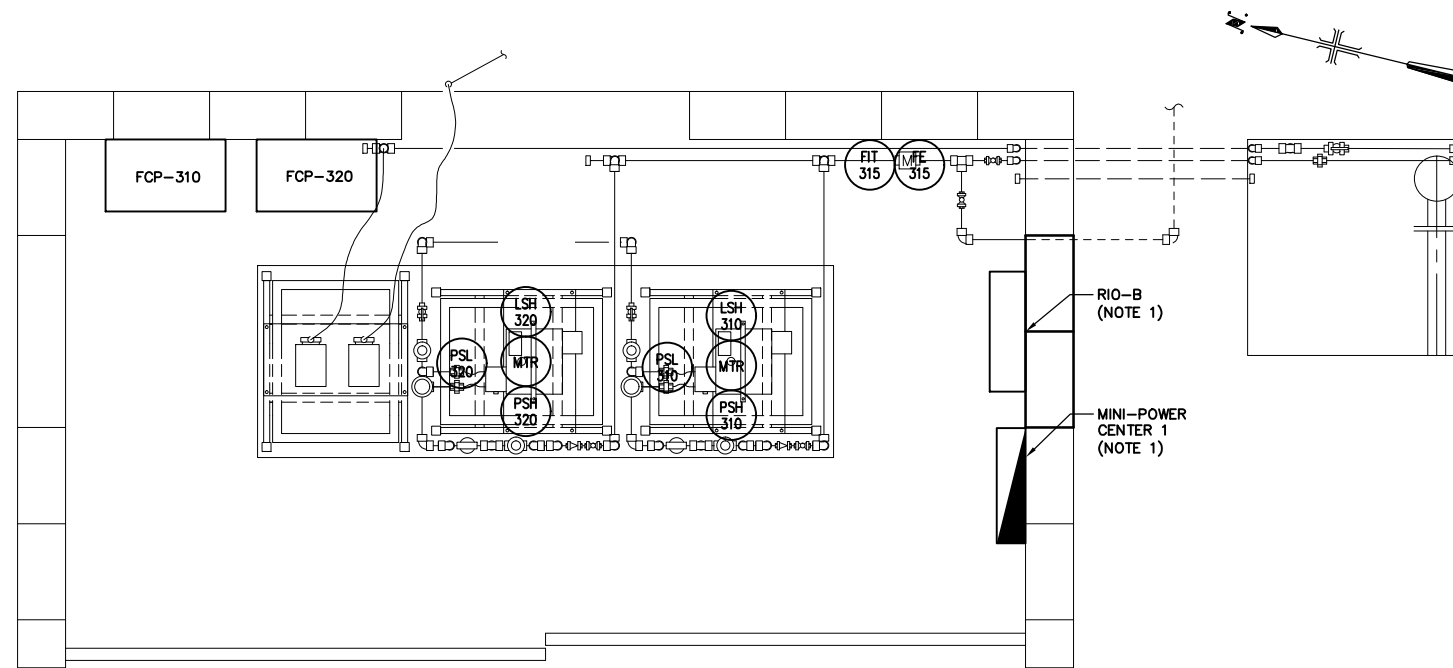

EXISTING METERING PUMP  
ENCLOSURE PLAN  
SCALE: 3/4"=1'-0"

NOTES:

1. CONTRACTOR TO BLOCK IN EXISTING WINDOW TO PROVIDE SPACE FOR EQUIPMENT MOUNTING.

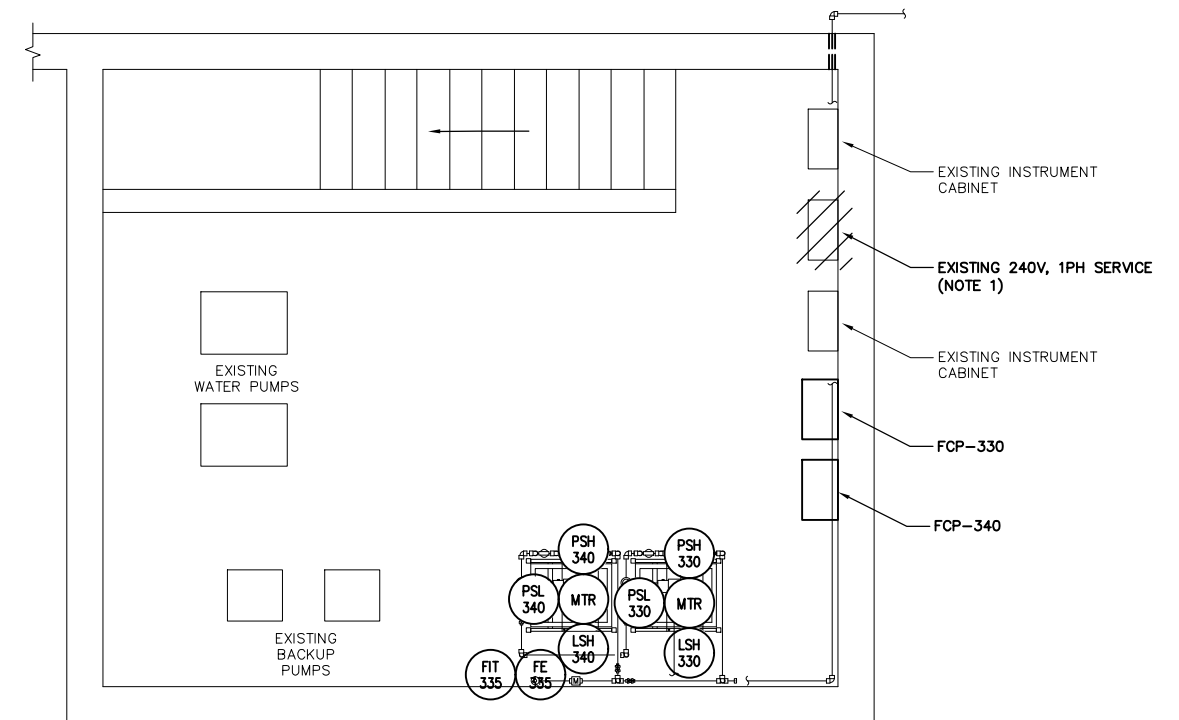

FILTRATION BUILDING BASEMENT  
SCALE: 3/8"=1'-0"

NOTES:

1. CONTRACTOR TO DISCONNECT AND REMOVE EXISTING 240V, 1 PHASE SERVICE AND ALL ASSOCIATED CONDUCTOR AND ABANDON CONDUIT IN PLACE.



REVISIONS			
NO.	BY	DATE	REMARKS

DES BY  
DWN BY  
CRD JAS

COVINA IRRIGATING COMPANY  
GLENORA, CALIFORNIA  
**UV/CHLORAMINES FOR TEMPLE WTP**

TEMPLE WATER TREATMENT PLANT  
**SODIUM HYPOCHLORITE/  
FILTRATION BUILDING POWER PLAN**  
SCALE: AS NOTED

COPYRIGHT © 2009  
MALCOLM PIRNIE, INC.  
DATE DECEMBER 2009  
E SHEET 7 OF 14  
CAD REF. NO. 5324A684

XREFS: \\... \XREF\LETCHEN.dwg ... \XREF\GPFCHEM.dwg ... \XREF\SGPCHEM.dwg ... \XREF\WPCHEM.dwg ... \XREF\MGPCHEM.dwg ... \XREF\5324-TBLK.dwg IMAGES: None  
 User: arivas Spec: PIRNIE STANDARD File: \\... \CAD\PROJ\5324002 Covina\ELEC\5324A683.DWG Scale: 1:1 Date: 12/03/2009 Time: 16:35 Layout: E-6

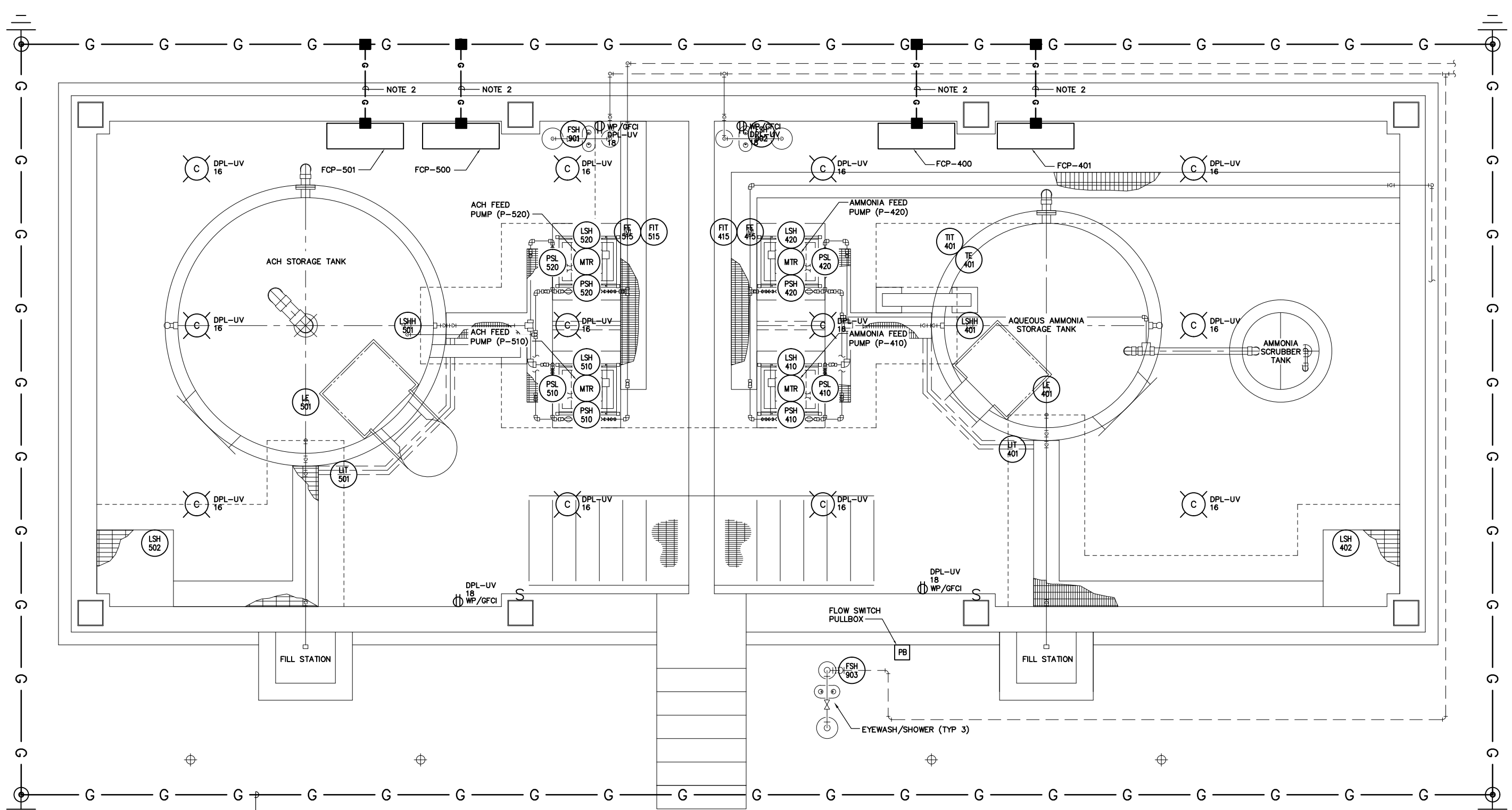

#4/0 BARE COPPER GROUND.  
DIRECT BURY 30" BELOW GRADE.

- NOTES:**
- SEE BLOCK DIAGRAMS ON SHEETS E-8 AND E-9 FOR POWER AND CONTROL CONDUIT INTERCONNECTION.
  - #4 BARE COPPER GROUND.
  - FOR LIGHT FIXTURES AND RECEPTACLES, THE CONTRACTOR SHALL FURNISH AND INSTALL 3/4" CONDUIT AND THE CORRECT NUMBER OF #12AWG CONDUCTORS FOR 20A CIRCUITS AND #10AWG CONDUCTORS FOR 30A CIRCUITS. DO NOT SHARE NEUTRALS. A MAXIMUM OF SIX CONDUCTORS SHALL BE INSTALLED IN A SINGLE CONDUIT.

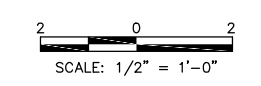

REVISIONS			
NO.	BY	DATE	REMARKS

DES BY  
DWN BY  
CRD JAS

COVINA IRRIGATING COMPANY  
GLEN DORA, CALIFORNIA  
**UV/CHLORAMINES FOR TEMPLE WTP**

TEMPLE WATER TREATMENT PLANT  
**CHEMICAL STORAGE FACILITY  
POWER PLAN**  
SCALE: 1/2"=1'-0"

COPYRIGHT © 2009  
MALCOLM PIRNIE, INC.  
DATE DECEMBER 2009  
E SHEET 6 OF 14  
CAD REF. NO. 5324A683

User: crivos Spec: PIRNIE STANDARD File: \\CAD\PROJ\5324002 Covina\ELEC\5324A685.DWG Scale: 1:1 Date: 12/03/2009 Time: 16:34 Layout: E-8

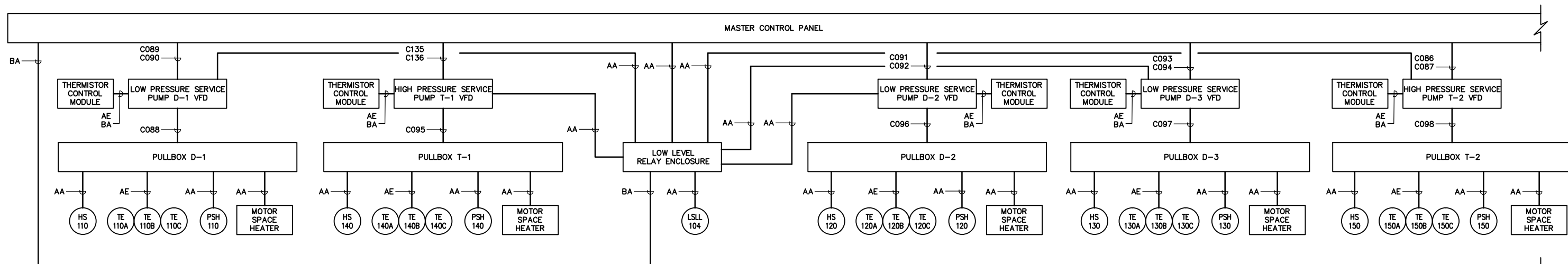

DPL-UV

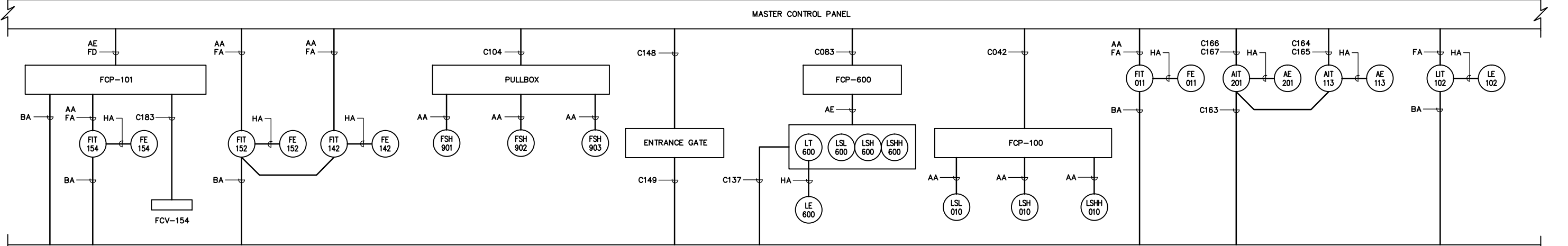

DPL-UV

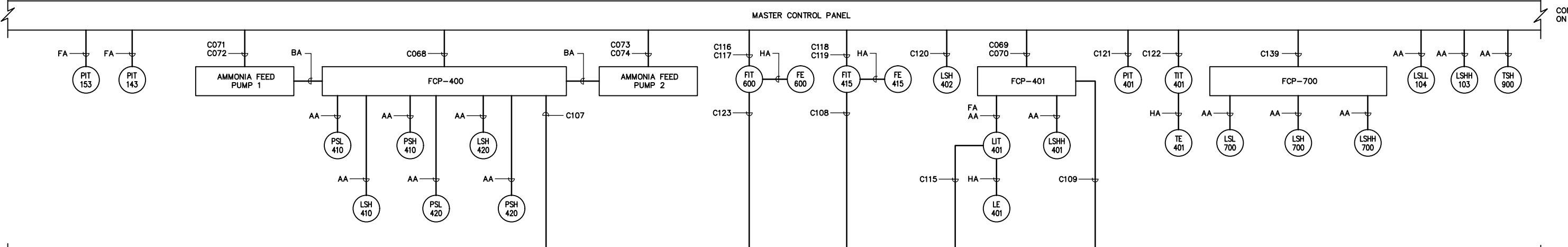

DPL-UV

CONTINUED ON E-9

CONTINUED ON E-9



REVISIONS			
NO.	BY	DATE	REMARKS

DES BY  
DWN BY  
CRD JAS

COVINA IRRIGATING COMPANY  
GLENORA, CALIFORNIA  
**UV/CHLORAMINES FOR TEMPLE WTP**

TEMPLE WATER TREATMENT PLANT  
**BLOCK DIAGRAM 1**

NO SCALE

COPYRIGHT © 2009  
MALCOLM PIRNIE, INC.  
DATE DECEMBER 2009  
E SHEET 8 OF 14  
CAD REF. NO. 5324A685

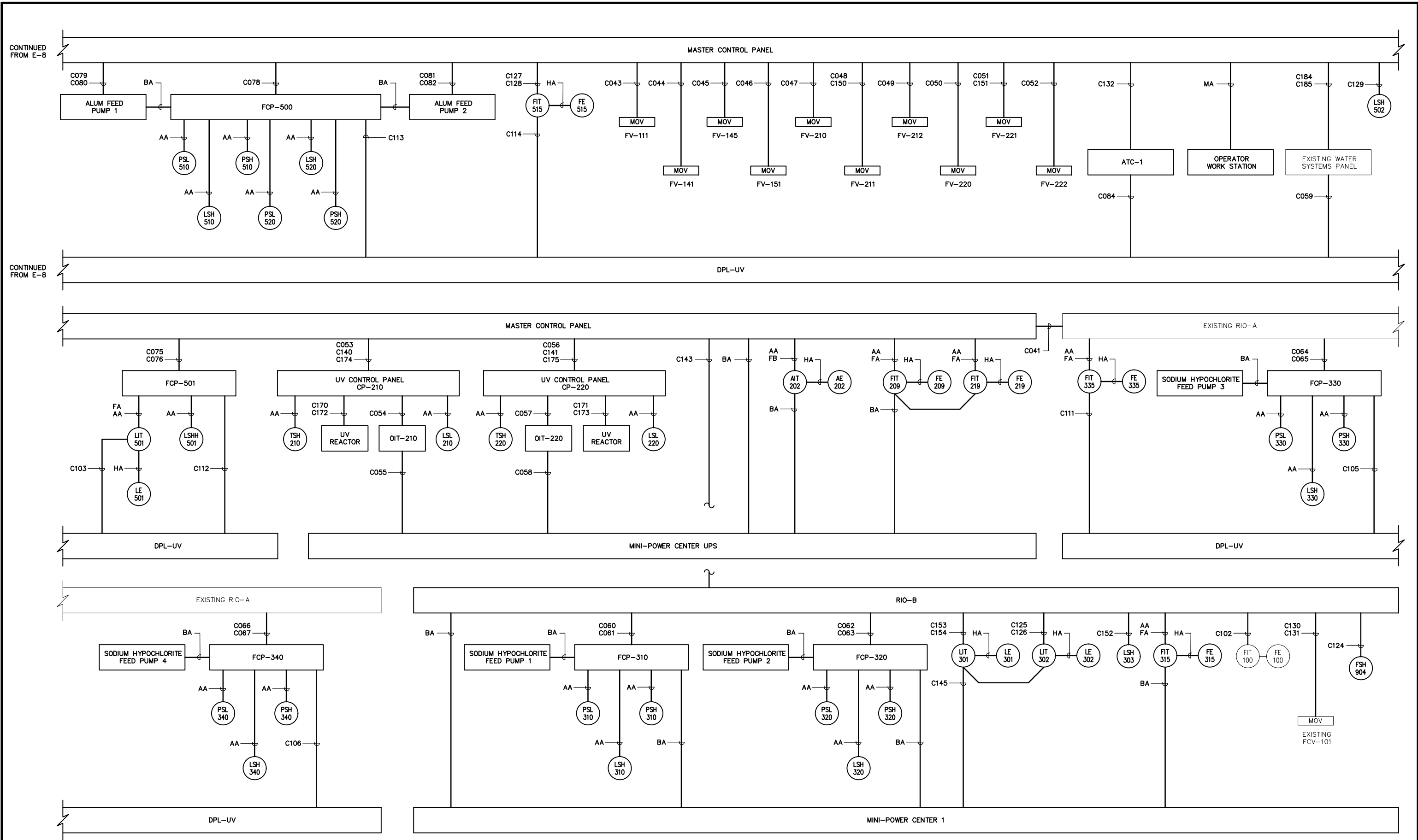

User: arivos Spec: PIRNIE\_STANDARD File: I:\CAD\PROJ\5324402 Covina\ELEC\53244A686.DWG Scale: 1:1 Date: 12/03/2009 Time: 16:34 Layout: E-9

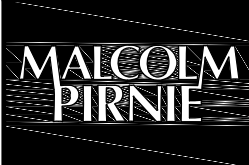

REVISIONS			
NO.	BY	DATE	REMARKS

DES BY  
 DWN BY  
 CRD JAS

COVINA IRRIGATING COMPANY  
 GLENDORA, CALIFORNIA  
**UV/CHLORAMINES FOR TEMPLE WTP**

TEMPLE WATER TREATMENT PLANT  
**BLOCK DIAGRAM 2**  
 NO SCALE

COPYRIGHT © 2009  
 MALCOLM PIRNIE, INC.  
 DATE DECEMBER 2009  
 E SHEET 9 OF 14  
 CAD REF. NO. 5324A686

User: arivos Spec: PIRNIE\_STANDARD File: \\ACAD\PROJ\5324002 Covina\ELEC\53244687.DWG Scale: 1:1 Date: 12/03/2009 Time: 16:34 Layout: E-10

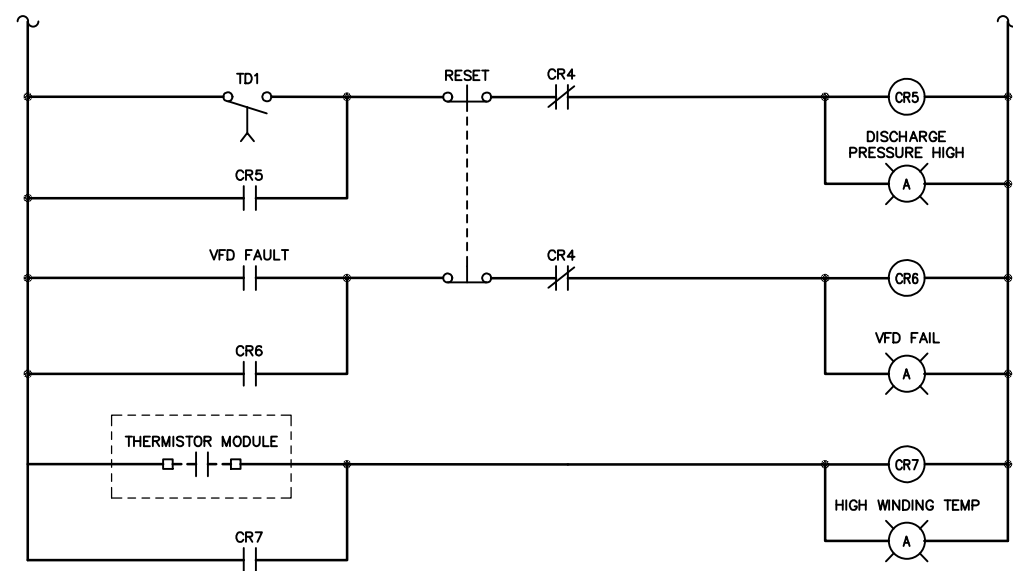
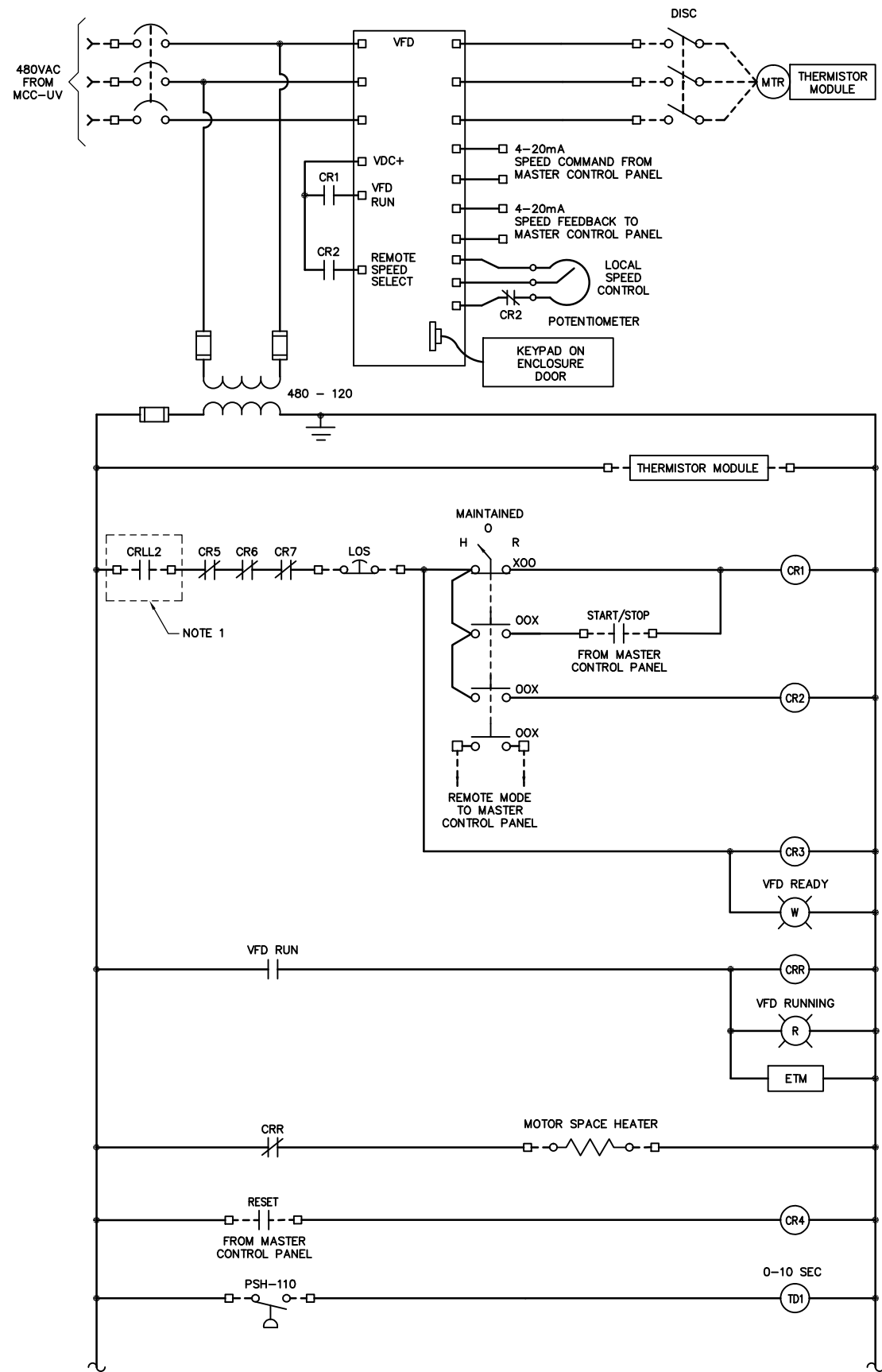

**LOW PRESSURE SERVICE PUMP D-1  
CONTROL SCHEMATIC**  
TYPICAL FOR LOW PRESSURE SERVICE PUMP D-2, D-3,  
HIGH PRESSURE SERVICE PUMP T-1, T-2

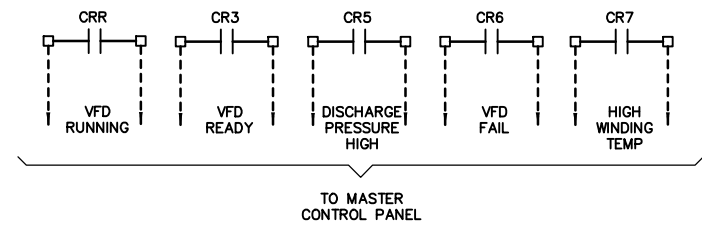

NOTES:  
1. LOW LEVEL RELAY ENCLOSURE. SEE SCHEMATIC ON SHEET E-11.



REVISIONS			
NO.	BY	DATE	REMARKS

DES BY  
DWN BY  
CRD JAS

COVINA IRRIGATING COMPANY  
GLEN DORA, CALIFORNIA  
**UV/CHLORAMINES FOR TEMPLE WTP**

TEMPLE WATER TREATMENT PLANT  
**CONTROL SCHEMATICS 1**

NO SCALE

COPYRIGHT © 2009  
MALCOLM PIRNIE, INC.  
DATE DECEMBER 2009  
E SHEET 10 OF 14  
CAD REF. NO. 5324A687



User: arivos Spec: PIRNIE\_STANDARD File: \\CAD\PROJ\5324002 Covina\ELEC\5324A688.DWG Scale: 1:1 Date: 12/03/2009 Time: 16:34 Layout: E-11

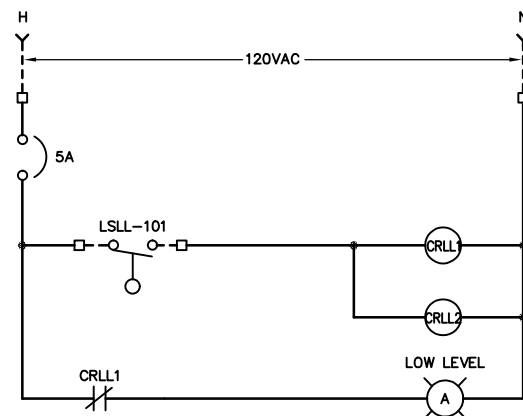

LOW LEVEL RELAY ENCLOSURE

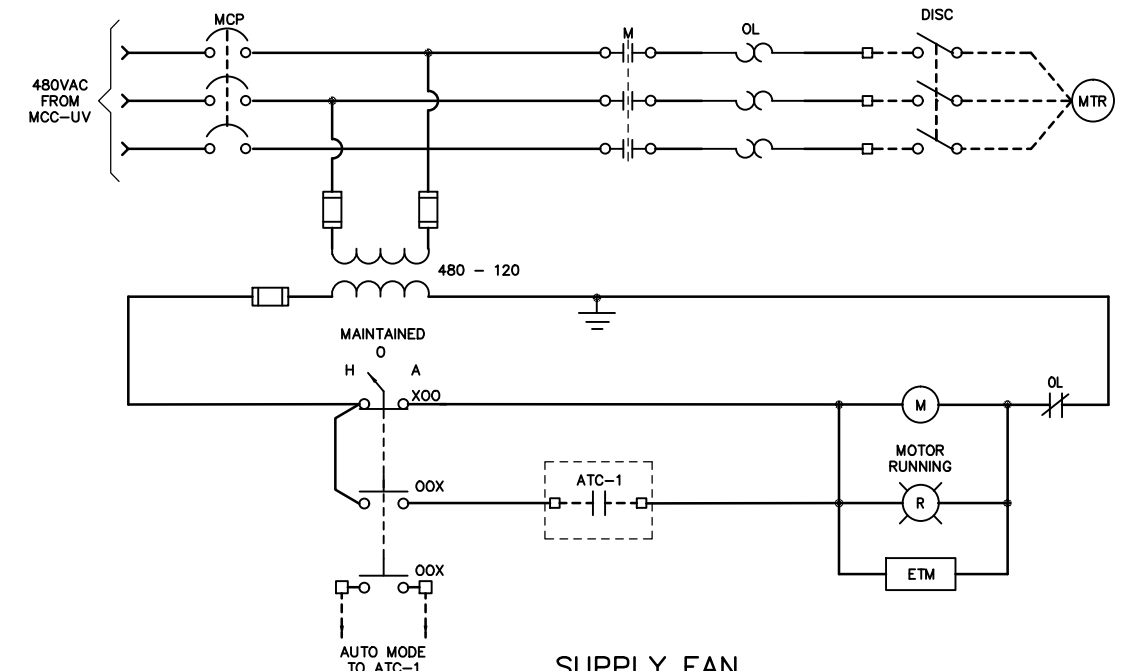
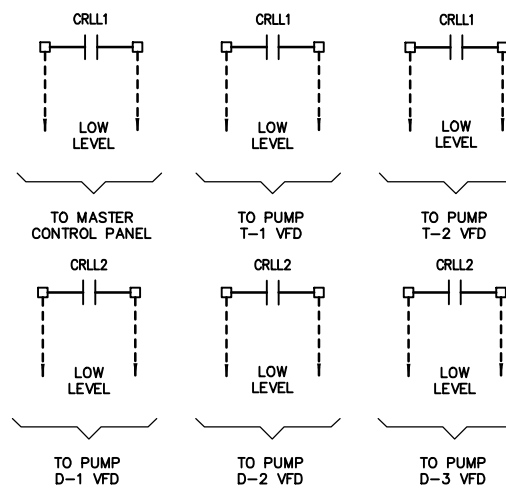

SUPPLY FAN CONTROL SCHEMATIC

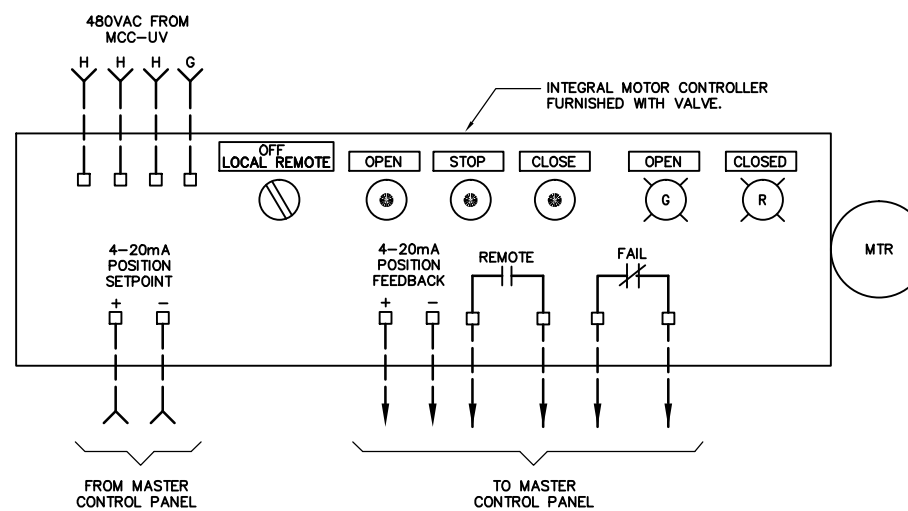
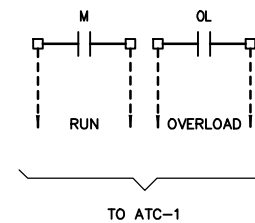

MOV FCV-101  
BLOCK DIAGRAM  
TYPICAL FOR FCV-211, FCV-221

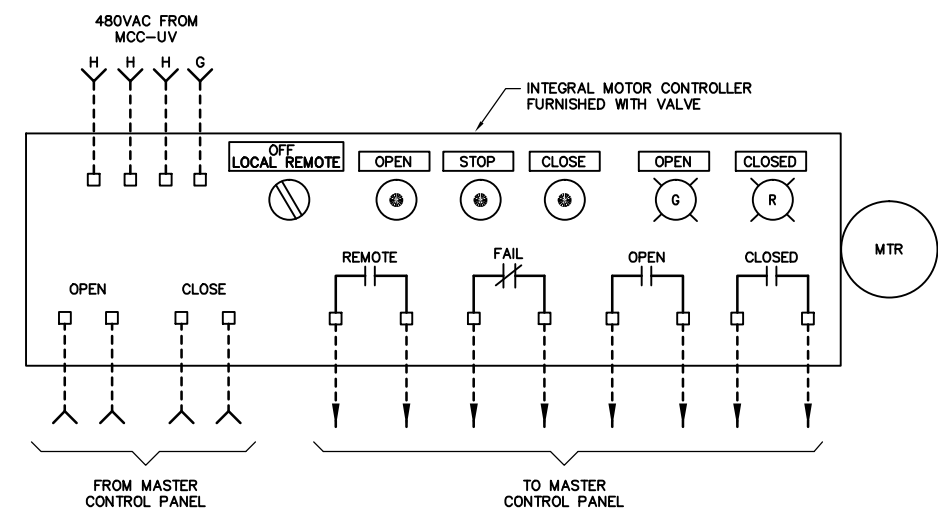

MOV FV-222  
BLOCK DIAGRAM  
TYPICAL FOR FV-111, FV-141, FV-145, FV-151,  
FV-210, FV-212, FV-220 AND FV-222



REVISIONS			
NO.	BY	DATE	REMARKS

DES BY  
DWN BY  
CRD JAS

COVINA IRRIGATING COMPANY  
GLEN DORA, CALIFORNIA  
**UV/CHLORAMINES FOR TEMPLE WTP**

TEMPLE WATER TREATMENT PLANT  
**CONTROL SCHEMATICS 2**

NO SCALE

COPYRIGHT © 2009  
MALCOLM PIRNIE, INC.  
DATE DECEMBER 2009  
E SHEET 11 OF 14  
CAD REF. NO. 5324A688

CONDUIT		CABLES				FROM	TO	REMARKS
NO.	SIZE	POWER	GROUND	CONTROL	INSTR			
C001	5"	BY SCE	BY SCE			SCE UTILITY POLE	SCE UTILITY TRANSFORMER	
C002	5"	BY SCE	BY SCE			SCE UTILITY TRANSFORMER	SERVICE ENTRANCE SECTION	
C003	5"	BY SCE	BY SCE			SCE UTILITY TRANSFORMER	SERVICE ENTRANCE SECTION	
C004	5"	BY SCE	BY SCE			SCE UTILITY TRANSFORMER	SERVICE ENTRANCE SECTION	
C005	5"	CO				SCE UTILITY TRANSFORMER	SERVICE ENTRANCE SECTION	
C006	5"	3 - 600 KCMIL	1 - #4/0			SERVICE ENTRANCE SECTION	MCC-UV	
C007	5"	3 - 600 KCMIL	1 - #4/0			SERVICE ENTRANCE SECTION	MCC-UV	
C008	5"	3 - 600 KCMIL	1 - #4/0			SERVICE ENTRANCE SECTION	MCC-UV	
C009	5"	3 - 600 KCMIL	1 - #4/0			SERVICE ENTRANCE SECTION	MCC-UV	
C010	3/4"	3 - #12	1 - #12			MCC-UV	AC-1	
C011	3/4"	3 - #12	1 - #12			MCC-UV	AC-2	
C012	3/4"	3 - #12	1 - #12			MCC-UV	SUPPLY FAN	
C013	3"	3 - 350 KCMIL	1 - #4			MCC-UV	EXISTING MCC	
C014	3/4"	3 - #12	1 - #12			MCC-UV	FCP-100	
C015	3/4"	3 - #12	1 - #12			FCP-100	UV RECYCLE PUMP 1	
C016	3/4"	3 - #12	1 - #12			FCP-100	UV RECYCLE PUMP 2	
C017	3/4"	3 - #8	1 - #10			MCC-UV	FCP-600	
C018	3/4"	3 - #12	1 - #12			MCC-UV	BACKWASH RECLAMATION PUMP 1	
C019	3/4"	3 - #12	1 - #12			MCC-UV	BACKWASH RECLAMATION PUMP 2	
C020	3/4"	3 - #12	1 - #12			MCC-UV	BACKWASH RECLAMATION PUMP 3	
C021	1"	2 - #4	1 - #8			MCC-UV	TRANSFORMER T-UV	
C022	1-1/2"	3 - #1	1 - #6			TRANSFORMER T-UV	DPL-UV	
C023	2-1/2"	3 - #4/0, 2 - #12	1 - #4			MCC-UV	HIGH PRESSURE PUMP T-1 VFD	
C024	2-1/2"	3 - #4/0, 2 - #12	1 - #4			MCC-UV	HIGH PRESSURE PUMP T-2 VFD	
C025	2-1/2"	3 - #8, 2 - #12	1 - #10			MCC-UV	LOW PRESSURE PUMP D-1 VFD	
C026	2-1/2"	3 - #4/0, 2 - #12	1 - #4			MCC-UV	LOW PRESSURE PUMP D-2 VFD	
C027	2-1/2"	3 - #4/0, 2 - #12	1 - #4			MCC-UV	LOW PRESSURE PUMP D-3 VFD	
C028	3/4"	3 - #12	1 - #12			MCC-UV	FV-111	
C029	3/4"	3 - #12	1 - #12			MCC-UV	FV-141, FV-145, FV-151	
C030	3/4"	3 - #12	1 - #12			MCC-UV	FV-210	
C031	3/4"	3 - #12	1 - #12			MCC-UV	FV-220	
C032	3/4"	3 - #12	1 - #12			MCC-UV	FV-212, FV-222	
C033	3"	3 - 350 KCMIL	1 - #4			MCC-UV	UPS SYSTEM	

CONDUIT		CABLES				FROM	TO	REMARKS
NO.	SIZE	POWER	GROUND	CONTROL	INSTR			
C034	3"	3 - 350 KCMIL	1 - #4			UPS SYSTEM	MCC-UV (UPS BUS)	
C035	2"	3 - #3/0	1 - #6			MCC-UV (UPS BUS)	UV CONTROL PANEL CP-210	
C036	4"	NOTE 1	NOTE 1			UV CONTROL PANEL CP-210	UV REACTOR 1	
C037	2"	3 - #3/0	1 - #6			MCC-UV (UPS BUS)	UV CONTROL PANEL CP-220	
C038	4"	NOTE 1	NOTE 1			UV CONTROL PANEL CP-220	UV REACTOR 2	
C039	3/4"	3 - #12	1 - #12			MCC-UV (UPS BUS)	EXISTING FCV-101	
C040	3/4"	3 - #12	1 - #12			MCC-UV (UPS BUS)	FCV-211, FCV-221	
C041	2"				ETHERNET	MASTER CONTROL PANEL	EXISTING RIO-A	
C042	3/4"		1 - #14	10 - #14		MASTER CONTROL PANEL	FCP-100	
C043	3/4"		1 - #14	16 - #14		MASTER CONTROL PANEL	FV-111	
C044	3/4"		1 - #14	16 - #14		MASTER CONTROL PANEL	FV-141	
C045	3/4"		1 - #14	16 - #14		MASTER CONTROL PANEL	FV-145	
C046	3/4"		1 - #14	16 - #14		MASTER CONTROL PANEL	FV-151	
C047	3/4"		1 - #14	16 - #14		MASTER CONTROL PANEL	FV-210	
C048	3/4"		1 - #14	4 - #14		MASTER CONTROL PANEL	FCV-211	
C049	3/4"		1 - #14	16 - #14		MASTER CONTROL PANEL	FV-212	
C050	3/4"		1 - #14	16 - #14		MASTER CONTROL PANEL	FV-220	
C051	3/4"		1 - #14	4 - #14		MASTER CONTROL PANEL	FCV-221	
C052	3/4"		1 - #14	16 - #14		MASTER CONTROL PANEL	FV-222	
C053	2"				ETHERNET	MASTER CONTROL PANEL	UV CONTROL PANEL CP-210	
C054	2"				ETHERNET	UV CONTROL PANEL CP-210	OIT-210	
C055	3/4"	2 - #12	1 - #12			MINI-POWER CENTER UPS	OIT-210	
C056	2"				ETHERNET	MASTER CONTROL PANEL	UV CONTROL PANEL CP-220	
C057	2"				ETHERNET	UV CONTROL PANEL CP-220	OIT-220	
C058	3/4"	2 - #12	1 - #12			MINI-POWER CENTER UPS	OIT-220	
C059	3/4"	2 - #12	1 - #12			DPL-UV	EXISTING SUBURBAN WATER SYSTEMS PANEL	
C060	3/4"		1 - #14	14 - #14		RIO-B	FCP-310	
C061	3/4"				2 - #16 STP	RIO-B	FCP-310	
C062	3/4"		1 - #14	14 - #14		RIO-B	FCP-320	
C063	3/4"				2 - #16 STP	RIO-B	FCP-320	
C064	3/4"		1 - #14	14 - #14		EXISTING RIO-A	FCP-330	
C065	3/4"				2 - #16 STP	EXISTING RIO-A	FCP-330	
C066	3/4"		1 - #14	14 - #14		EXISTING RIO-A	FCP-340	
C067	3/4"				2 - #16 STP	EXISTING RIO-A	FCP-340	

User: orivas Spec: PIRNIE STANDARD File: \\CAD\PROJ\5324002 Covina\ELEC\53244689.DWG Scale: 1:1 Date: 12/03/2009 Time: 16:33 Layout: E-12

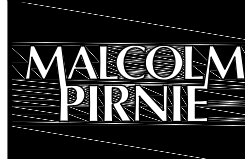

REVISIONS			
NO.	BY	DATE	REMARKS

DES BY  
DWN BY  
CRD JAS

COVINA IRRIGATING COMPANY  
GLEN DORA, CALIFORNIA  
**UV/CHLORAMINES FOR TEMPLE WTP**

TEMPLE WATER TREATMENT PLANT  
**CABLE AND CONDUIT SCHEDULE 1**  
NO SCALE

COPYRIGHT © 2009  
MALCOLM PIRNIE, INC.  
DATE DECEMBER 2009  
E SHEET 12 OF 14  
CAD REF. NO. 5324A689

CONDUIT		CABLES				FROM	TO	REMARKS
NO.	SIZE	POWER	GROUND	CONTROL	INSTR			
C068	3/4"		1 - #14	4 - #14		MASTER CONTROL PANEL	FCP-400	
C069	3/4"		1 - #14	4 - #14		MASTER CONTROL PANEL	FCP-401	
C070	3/4"				1 - #16 STP	MASTER CONTROL PANEL	FCP-401	
C071	3/4"		1 - #14	10 - #14		MASTER CONTROL PANEL	AMMONIA FEED PUMP 1	
C072	3/4"				2 - #16 STP	MASTER CONTROL PANEL	AMMONIA FEED PUMP 1	
C073	3/4"		1 - #14	10 - #14		MASTER CONTROL PANEL	AMMONIA FEED PUMP 2	
C074	3/4"				2 - #16 STP	MASTER CONTROL PANEL	AMMONIA FEED PUMP 2	
C075	3/4"		1 - #14	4 - #14		MASTER CONTROL PANEL	FCP-501	
C076	3/4"				1 - #16 STP	MASTER CONTROL PANEL	FCP-501	
C077	2-1/2"	3 - #4/0, 2 - #12	1 - #4			HIGH PRESSURE PUMP T-1 VFD	HIGH PRESSURE PUMP T-1	
C078	3/4"		1 - #14	4 - #14		MASTER CONTROL PANEL	FCP-500	
C079	3/4"		1 - #14	10 - #14		MASTER CONTROL PANEL	ALUM FEED PUMP 1	
C080	3/4"				2 - #16 STP	MASTER CONTROL PANEL	ALUM FEED PUMP 1	
C081	3/4"		1 - #14	10 - #14		MASTER CONTROL PANEL	ALUM FEED PUMP 2	
C082	3/4"				2 - #16 STP	MASTER CONTROL PANEL	ALUM FEED PUMP 2	
C083	3/4"		1 - #14	14 - #14		MASTER CONTROL PANEL	FCP-600	
C084	3/4"	2 - #12	1 - #12			DPL-UV	ATC-1	
C085	3"	3 - 350 KCMIL	1 - #4			TRANSFORMER T-A	EXISTING PANEL A	
C086	1"				2 - #16 STP	MASTER CONTROL PANEL	HIGH PRESSURE PUMP T-2 VFD	
C087	3/4"		1 - #14	10 - #14		MASTER CONTROL PANEL	HIGH PRESSURE PUMP T-2 VFD	
C088	1"		1 - #14	14 - #14		LOW PRESSURE PUMP D-1 VFD	PULLBOX D-1	
C089	1"				2 - #16 STP	MASTER CONTROL PANEL	LOW PRESSURE PUMP D-1 VFD	
C090	3/4"		1 - #14	10 - #14		MASTER CONTROL PANEL	LOW PRESSURE PUMP D-1 VFD	
C091	1"				2 - #16 STP	MASTER CONTROL PANEL	LOW PRESSURE PUMP D-2 VFD	
C092	3/4"		1 - #14	10 - #14		MASTER CONTROL PANEL	LOW PRESSURE PUMP D-2 VFD	
C093	1"				2 - #16 STP	MASTER CONTROL PANEL	LOW PRESSURE PUMP D-3 VFD	
C094	3/4"		1 - #14	10 - #14		MASTER CONTROL PANEL	LOW PRESSURE PUMP D-3 VFD	
C095	1"		1 - #14	14 - #14		HIGH PRESSURE PUMP T-1 VFD	PULLBOX T-1	
C096	1"		1 - #14	14 - #14		LOW PRESSURE PUMP D-2 VFD	PULLBOX D-2	
C097	1"		1 - #14	14 - #14		LOW PRESSURE PUMP D-3 VFD	PULLBOX D-3	
C098	1"		1 - #14	14 - #14		HIGH PRESSURE PUMP T-2 VFD	PULLBOX T-2	
C099	2-1/2"	3 - #4/0, 2 - #12	1 - #4			HIGH PRESSURE PUMP T-2 VFD	HIGH PRESSURE PUMP T-2	
C100	2-1/2"	3 - #4/0, 2 - #12	1 - #4			LOW PRESSURE PUMP D-2 VFD	LOW PRESSURE PUMP D-2	
C101	2-1/2"	3 - #4/0, 2 - #12	1 - #4			LOW PRESSURE PUMP D-3 VFD	LOW PRESSURE PUMP D-3	
C102	3/4"				1 - #16 STP	RIO-B	EXISTING FIT-100	

CONDUIT		CABLES				FROM	TO	REMARKS
NO.	SIZE	POWER	GROUND	CONTROL	INSTR			
C103	3/4"	2 - #12	1 - #12			DPL-UV	LIT-501	
C104	3/4"		1 - #14	6 - #14		MASTER CONTROL PANEL	FLOW SWITCH PULLBOX	
C105	3/4"	2 - #12	1 - #12			DPL-UV	FCP-330	
C106	3/4"	2 - #12	1 - #12			DPL-UV	FCP-340	
C107	3/4"	2 - #12	1 - #12			DPL-UV	FCP-400	
C108	3/4"	2 - #12	1 - #12			DPL-UV	FIT-415	
C109	3/4"	2 - #12	1 - #12			DPL-UV	FCP-401	
C110	3/4"	3 - #12	1 - #12			MCC-UV	ENTRANCE GATE	
C111	3/4"	2 - #12	1 - #12			DPL-UV	FIT-335	
C112	3/4"	2 - #12	1 - #12			DPL-UV	FCP-501	
C113	3/4"	2 - #12	1 - #12			DPL-UV	FCP-500	
C114	3/4"	2 - #12	1 - #12			DPL-UV	FIT-515	
C115	3/4"	2 - #12	1 - #12			DPL-UV	LIT-401	
C116	3/4"				1 - #16 STP	MASTER CONTROL PANEL	FIT-600	
C117	3/4"		1 - #14	2 - #14		MASTER CONTROL PANEL	FIT-600	
C118	3/4"				1 - #16 STP	MASTER CONTROL PANEL	FIT-415	
C119	3/4"		1 - #14	2 - #14		MASTER CONTROL PANEL	FIT-415	
C120	3/4"		1 - #14	2 - #14		MASTER CONTROL PANEL	LSH-402	
C121	3/4"				1 - #16 STP	MASTER CONTROL PANEL	PIT-401	
C122	3/4"				1 - #16 STP	MASTER CONTROL PANEL	TIT-401	
C123	3/4"	2 - #12	1 - #12			DPL-UV	FIT-600	
C124	3/4"		1 - #14	2 - #14		RIO-B	FSH-904	
C125	3/4"				1 - #16 STP	RIO-B	LIT-302	
C126	3/4"		1 - #14	2 - #14		RIO-B	LIT-302	
C127	3/4"				1 - #16 STP	MASTER CONTROL PANEL	FIT-515	
C128	3/4"		1 - #14	2 - #14		MASTER CONTROL PANEL	FIT-515	
C129	3/4"		1 - #14	2 - #14		MASTER CONTROL PANEL	LSH-502	
C130	3/4"				2 - #16 STP	RIO-B	EXISTING FCV-101	
C131	3/4"		1 - #14	4 - #14		RIO-B	EXISTING FCV-101	
C132	3/4"		1 - #14	6 - #14		MASTER CONTROL PANEL	ATC-1	
C133	2-1/2"	3 - #8, 2 - #12	1 - #10			LOW PRESSURE PUMP D-1 VFD	LOW PRESSURE PUMP D-1	
C134	1-1/2"	2 - #1/0	1 - #6			MCC-UV	TRANSFORMER T-A	
C135	1"				2 - #16 STP	MASTER CONTROL PANEL	HIGH PRESSURE PUMP T-1 VFD	
C136	3/4"		1 - #14	10 - #14		MASTER CONTROL PANEL	HIGH PRESSURE PUMP T-1 VFD	
C137	3/4"	2 - #12	1 - #12			DPL-UV	LT-600	

User: orivas Spec: PIRNIE STANDARD File: \\CAD\PROJ\5324602 Covina\ELEC\53244690.DWG Scale: 1:1 Date: 12/03/2009 Time: 16:33 Layout: E-13



REVISIONS			
NO.	BY	DATE	REMARKS

DES BY  
DWN BY  
CRD JAS

COVINA IRRIGATING COMPANY  
GLEN DORA, CALIFORNIA  
**UV/CHLORAMINES FOR TEMPLE WTP**

TEMPLE WATER TREATMENT PLANT  
**CABLE AND CONDUIT SCHEDULE 2**  
NO SCALE

COPYRIGHT © 2009 MALCOLM PIRNIE, INC.  
DATE DECEMBER 2009  
E SHEET 13 OF 14  
CAD REF. NO. 5324A690

User: orivas Spec: PIRNIE\_STANDARD File: \\CAD\PROJ\53244002\_Covina\ELEC\53244A691.DWG Scale: 1:1 Date: 12/03/2009 Time: 16:33 Layout: E-14

CONDUIT		CABLES				FROM	TO	REMARKS
NO.	SIZE	POWER	GROUND	CONTROL	INSTR			
C138	3/4"	3 - #12	1 - #12			MCC-UV	FCP-700	
C139	3/4"		1 - #14	10 - #14		MASTER CONTROL PANEL	FCP-700	
C140	1"				2 - #16 STP	MASTER CONTROL PANEL	UV CONTROL PANEL CP-210	AIT/FIT SIGNALS
C141	1"				2 - #16 STP	MASTER CONTROL PANEL	UV CONTROL PANEL CP-220	AIT/FIT SIGNALS
C142	3/4"	2 - #10	1 - #10			MCC-UV	MIN-POWER CENTER 1	
C143	2"				ETHERNET	MASTER CONTROL PANEL	RIO-B	
C144	3/4"	3 - #12	1 - #12			MCC-UV	SAMPLE PUMP	
C145	3/4"	2 - #12	1 - #12			MIN-POWER CENTER 1	LIT-301, LIT-302	
C146	3/4"	3 - #12	1 - #12			FCP-700	STORM WATER PUMP 1	
C147	3/4"	3 - #12	1 - #12			FCP-700	STORM WATER PUMP 2	
C148	3/4"		1 - #14	6 - #14		MASTER CONTROL PANEL	ENTRANCE GATE	
C149	3/4"	2 - #12	1 - #12			DPL-UV	ENTRANCE GATE	
C150	1"				2 - #16 STP	MASTER CONTROL PANEL	FCV-211	
C151	1"				2 - #16 STP	MASTER CONTROL PANEL	FCV-221	
C152	3/4"		1 - #14	2 - #14		RIO-B	LSH-303	
C153	3/4"				1 - #16 STP	RIO-B	LIT-301	
C154	3/4"		1 - #14	2 - #14		RIO-B	LIT-301	
C155	2"	CO				UV FACILITY ELECTRICAL ROOM	EHH	SPARE
C156	2"	CO				UV FACILITY ELECTRICAL ROOM	EHH	SPARE
C157	2"	CO				UV FACILITY ELECTRICAL ROOM	EHH	SPARE
C158	2"	CO				UV FACILITY ELECTRICAL ROOM	EHH	SPARE
C159	2"	CO				UV FACILITY ELECTRICAL ROOM	IHH	SPARE
C160	2"	CO				UV FACILITY ELECTRICAL ROOM	IHH	SPARE
C161	2"	CO				UV FACILITY ELECTRICAL ROOM	IHH	SPARE
C162	2"	CO				UV FACILITY ELECTRICAL ROOM	IHH	SPARE
C163	3/4"	2 - #12	1 - #12			DPL-UV	AIT-113, AIT-201	

CONDUIT		CABLES				FROM	TO	REMARKS
NO.	SIZE	POWER	GROUND	CONTROL	INSTR			
C164	3/4"		1 - #14	2 - #14		MASTER CONTROL PANEL	AIT-113	
C165	3/4"				3 - #16 STP	MASTER CONTROL PANEL	AIT-113	
C166	3/4"		1 - #14	2 - #14		MASTER CONTROL PANEL	AIT-201	
C167	3/4"				1 - #16 STP	MASTER CONTROL PANEL	AIT-201	
C168	4"	NOTE 1	NOTE 1			UV CONTROL PANEL CP-210	UV REACTOR 1	
C169	4"	NOTE 1	NOTE 1			UV CONTROL PANEL CP-220	UV REACTOR 2	
C170	1"		1 - #14	14 - #14		UV CONTROL PANEL CP-210	UV REACTOR 1	
C171	1"		1 - #14	14 - #14		UV CONTROL PANEL CP-220	UV REACTOR 2	
C172	2"				6 - #16 STP	UV CONTROL PANEL CP-210	UV REACTOR 1	
C173	2"				6 - #16 STP	UV CONTROL PANEL CP-220	UV REACTOR 2	
C174	1"		1 - #14	14 - #14		MASTER CONTROL PANEL	UV CONTROL PANEL CP-210	
C175	1"		1 - #14	14 - #14		MASTER CONTROL PANEL	UV CONTROL PANEL CP-220	
C176	1"	3 - #8	1 - #10			MCC-UV	MIN-POWER CENTER UPS	
C177	2"	CO				ENTRANCE GATE PULLBOX	FUTURE GATE OPERATOR	STUB AND CAP
C178	2"	CO				ENTRANCE GATE PULLBOX	FUTURE GATE OPERATOR	STUB AND CAP
C179	2"	CO				ENTRANCE GATE PULLBOX	FUTURE GATE OPERATOR	STUB AND CAP
C180	2"	CO				ENTRANCE GATE PULLBOX	FUTURE GATE OPERATOR	STUB AND CAP
C181	2"	CO				ENTRANCE GATE PULLBOX	FUTURE GATE OPERATOR	STUB AND CAP
C182	2"	CO				ENTRANCE GATE PULLBOX	FUTURE GATE OPERATOR	STUB AND CAP
C183	3/4"	4 - #12	1 - #12			FCP-101	FCV-154	
C184	3/4"				2 - #16 STP	MASTER CONTROL PANEL	EXISTING SUBURBAN WATER SYSTEMS PANEL	
C185	3/4"		1 - #14	8 - #14		MASTER CONTROL PANEL	EXISTING SUBURBAN WATER SYSTEMS PANEL	

**NOTES:**

- CABLES SHALL BE FURNISHED BY THE UV VENDOR. CABLES SHALL BE INSTALLED AND TERMINATED BY THE CONTRACTOR. INCLUDE PULL STRING WITH CABLES.



REVISIONS			
NO.	BY	DATE	REMARKS

DES BY  
DWN BY  
CRD JAS

COVINA IRRIGATING COMPANY  
GLEN DORA, CALIFORNIA  
**UV/CHLORAMINES FOR TEMPLE WTP**

TEMPLE WATER TREATMENT PLANT  
**CABLE AND CONDUIT SCHEDULE 3**  
NO SCALE

COPYRIGHT © 2009  
MALCOLM PIRNIE, INC.  
DATE DECEMBER 2009  
E SHEET 14 OF 14  
CAD REF. NO. 5324A691

**DEVICE IDENTIFICATION LEGEND**

LETTER	FIRST LETTER		SUCCEEDING LETTERS		
	MEASURED OR INITIATING VARIABLE ANALYSIS	MODIFIER	READOUT OR PASSIVE FUNCTION ALARM	OUTPUT FUNCTION	MODIFIER
B	BURNER, COMBUSTION		USER'S CHOICE	USER'S CHOICE	USER'S CHOICE
C	CONDUCTIVITY (ELECTRICAL)		CONTROLLER	CONTROL	CLOSED
D	DENSITY (MASS), SPECIFIC GRAVITY	DIFFERENTIAL	DIFFERENTIAL		
E	VOLTAGE (EMF)		PRIMARY ELEMENT		
F	FLOW RATE	RATIO (FRACTION)	RATIO		
G	STATUS		GLASS		
H	HAND (MANUALLY INITIATED)				HIGH
I	CURRENT (ELECTRICAL)		INDICATE		
J	POWER	SCAN			
K	TIME, TIME-SCHEDULE	TIME RATE OF CHANGE		CONTROL STATION	
L	LEVEL		LIGHT (PILOT)		LOW
M	MOISTURE, HUMIDITY	MOMENTARY			MIDDLE, INTERMEDIATE
N	SEQUENCE		USER'S CHOICE	USER'S CHOICE	USER'S CHOICE
O	ORIFICE (RESTRICTION)		ORIFICE (RESTRICTION)		OPEN
P	PRESSURE, VACUUM		POINT (TEST CONNECTION)		
Q	QUANTITY	INTEGRATE, TOTALIZE			
R	RADIATION		RECORD		
S	SPEED, FREQUENCY	SAFETY		SWITCH	
T	TEMPERATURE		TRANSMIT		
U	MULTIVARIABLE		MULTIFUNCTION	MULTIFUNCTION	MULTIFUNCTION
V	VIBRATION, MECH. ANALYSIS			VALVE, DAMPER, OR LOUVER	
W	WEIGHT, FORCE		WELL		
X	MOTION	X AXIS	UNCLASSIFIED	UNCLASSIFIED	UNCLASSIFIED
Y	EVENT, STATE, OR PRESENCE	Y AXIS		RELAY, COMPUTE, CONVERT	
Z	POSITION, DIMENSION			DRIVE, ACTUATOR, UNCLASSIFIED FINAL CONTROL ELEMENT	

**PROCESS SYMBOLS**

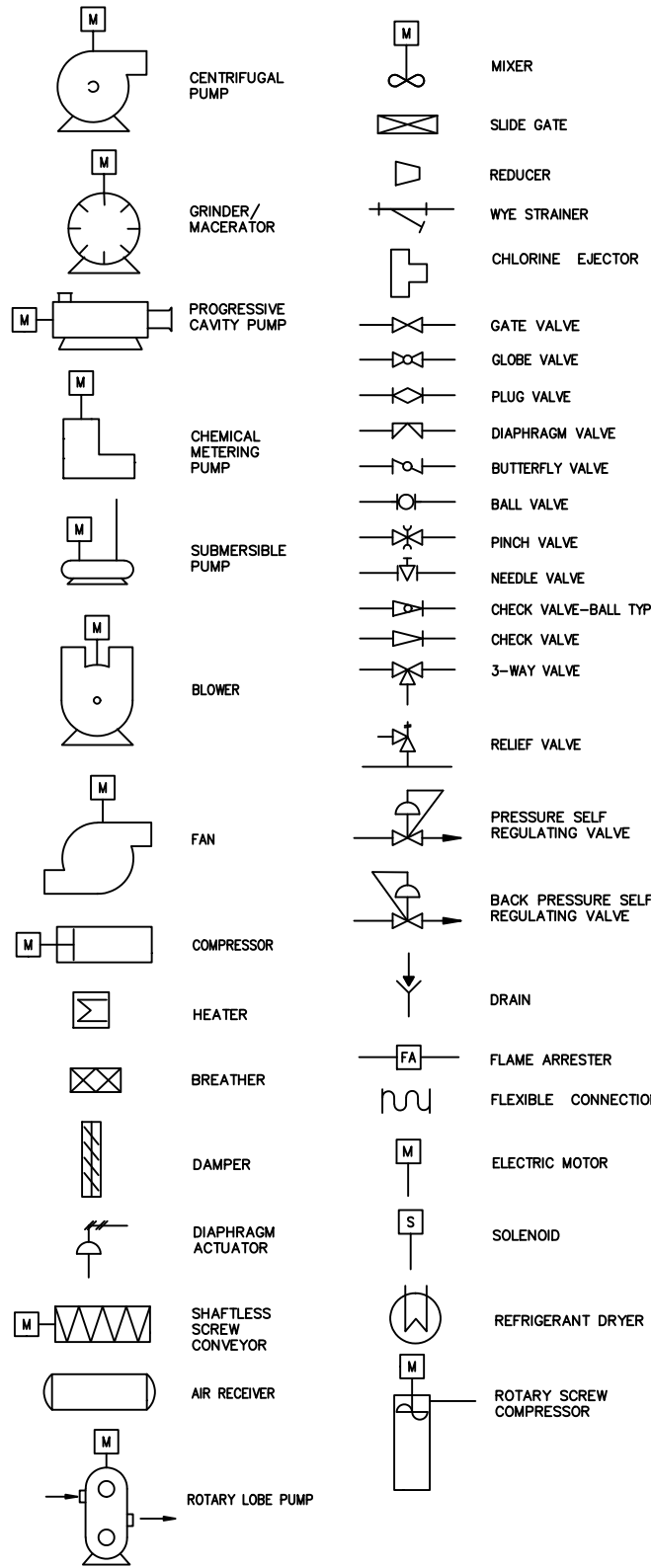

**PRIMARY ELEMENTS SYMBOLS**

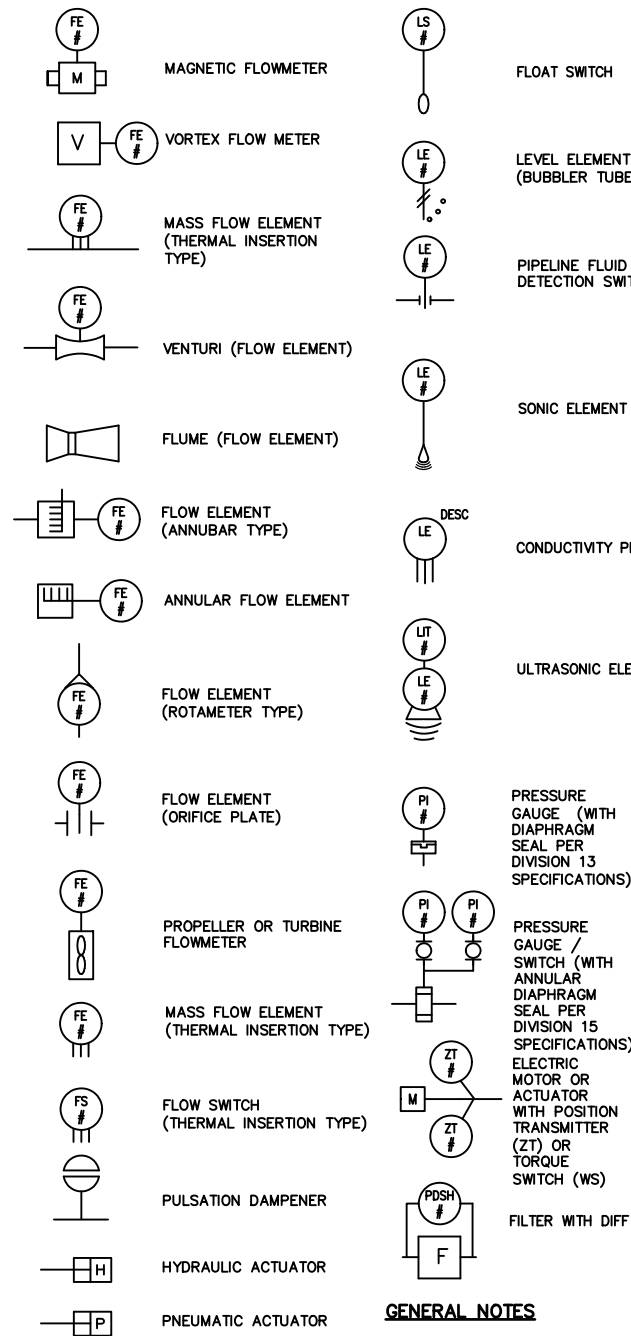

**ELECTRICAL SYMBOLS**

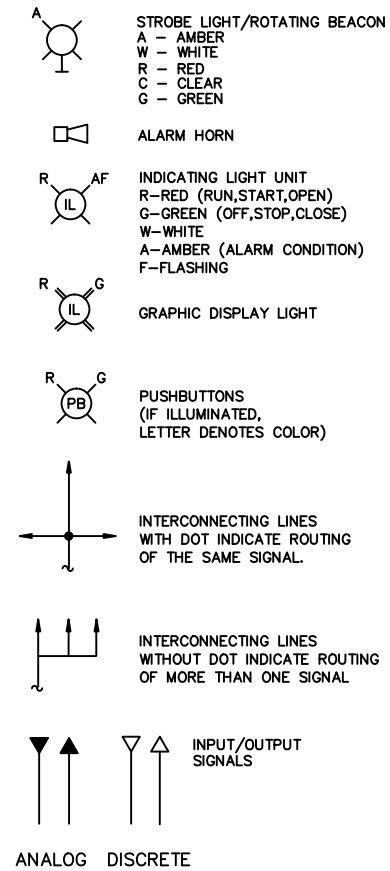

**LINE SYMBOLS**

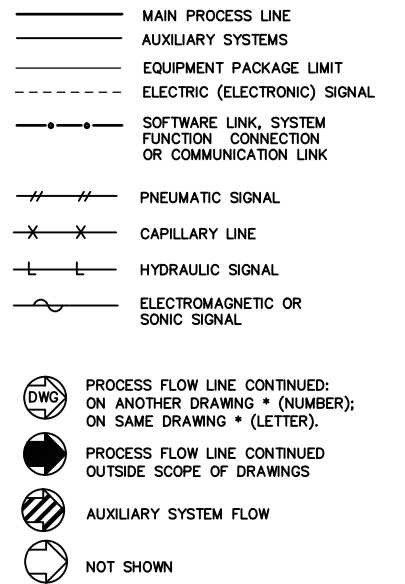

**ABBREVIATIONS**

DR	DRAIN
HMI	HUMAN MACHINE INTERFACE
SA	SAMPLE LINE
UPS	UNINTERRUPTIBLE POWER SUPPLY
UVR	UV RECYCLE
VE	VENT
XMTR	TRANSMITTER

**GENERAL INSTRUMENT SYMBOLS**

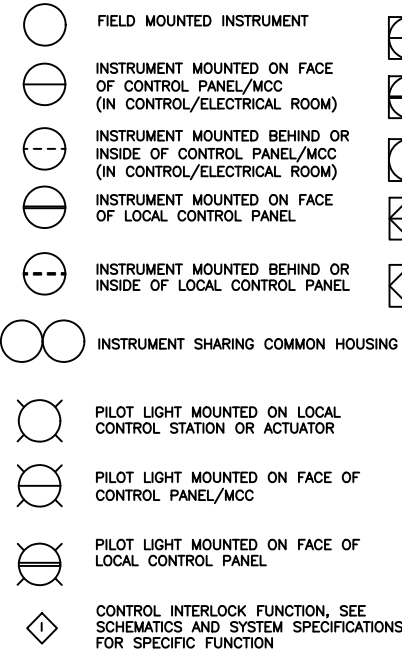

**CONTROL SYSTEM INTERFACE SYMBOLS**

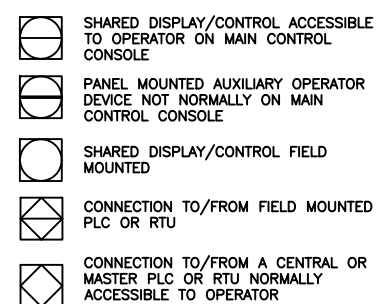

**TAG NUMBERS AND ADDITIONAL DESIGNATIONS**

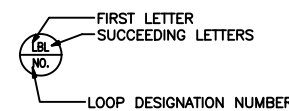

**GENERAL NOTES**

- IN GENERAL, THE P & ID SYMBOLS AND DEVICE IDENTIFICATIONS ARE BASED ON INTERNATIONAL SOCIETY OF AUTOMATION, STANDARD PRACTICE ISA-5.1-1984 (R1992). SOME MODIFICATIONS, ADDITIONS, AND ALTERATIONS HAVE BEEN MADE AS NEEDED TO ACCOMMODATE THE PROJECT REQUIREMENTS.
- SOME CONTROL AND INTERLOCK REQUIREMENTS WHICH CAN BE MORE CLEARLY ILLUSTRATED ON SCHEMATIC DRAWINGS HAVE BEEN OMITTED FROM THE P & ID DRAWINGS.
- THIS IS A GENERAL LEGEND SHEET. SOME SYMBOLS AND ABBREVIATIONS MAY NOT BE UTILIZED ON THIS SPECIFIC PROJECT.
- PIPING AND EQUIPMENT LEGEND APPLIES TO P & ID SHEETS ONLY AND MAY DIFFER FROM LEGENDS FOR OTHER SHEETS.



NO.		BY	DATE	REVISIONS	REMARKS

DES	SZ
DWN	SZ
CKD	EN

COVINA IRRIGATING COMPANY  
 GLENDORA, CALIFORNIA  
**UV/CHLORAMINES FOR TEMPLE WTP**

TEMPLE WATER TREATMENT PLANT  
**INSTRUMENTATION AND CONTROL SYMBOLS AND LEGENDS**  
 NTS

COPYRIGHT © 2009  
 MALCOLM PIRNIE, INC.  
 DATE DECEMBER 2009  
 GI SHEET 1 OF 3  
 CAD REF. NO. 5324A700

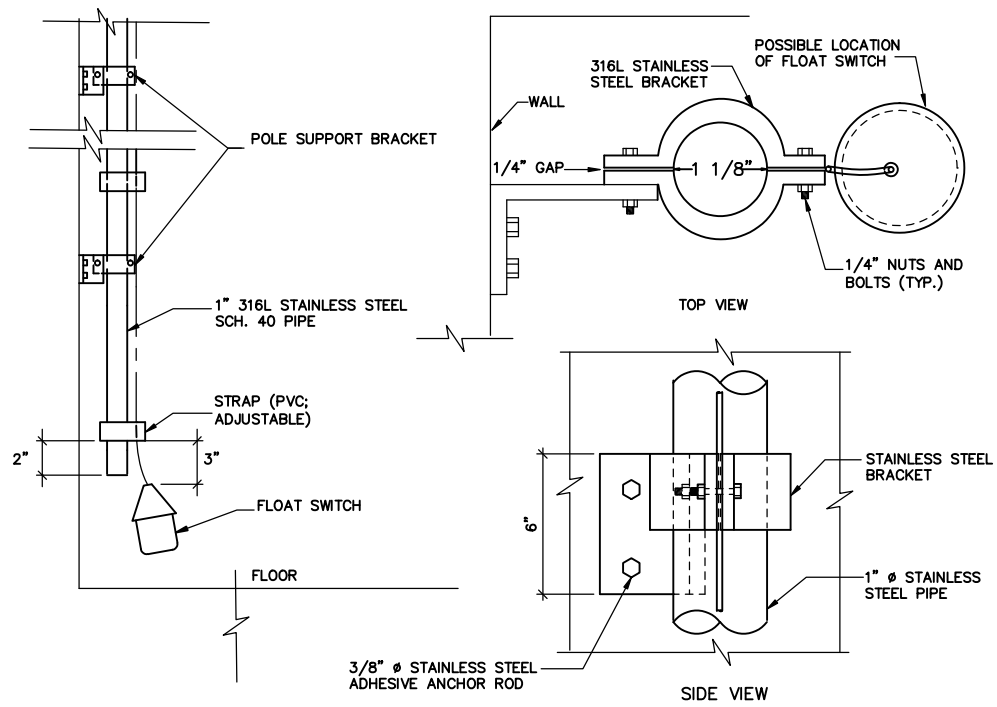

SUMP FLOAT SWITCH MOUNTING DETAIL

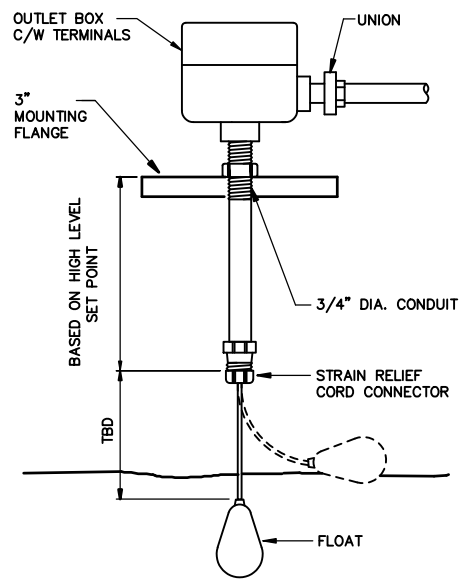

CHEMICAL TANK FLOAT SWITCH MOUNTING DETAIL

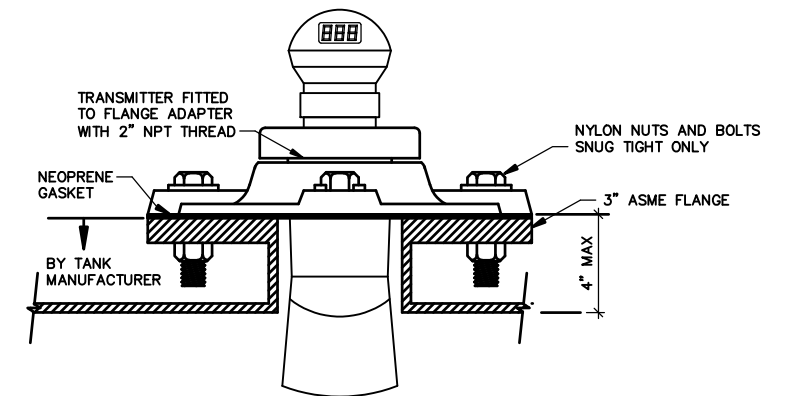

CHEMICAL TANK ULTRASONIC LEVEL TRANSMITTER MOUNTING DETAIL

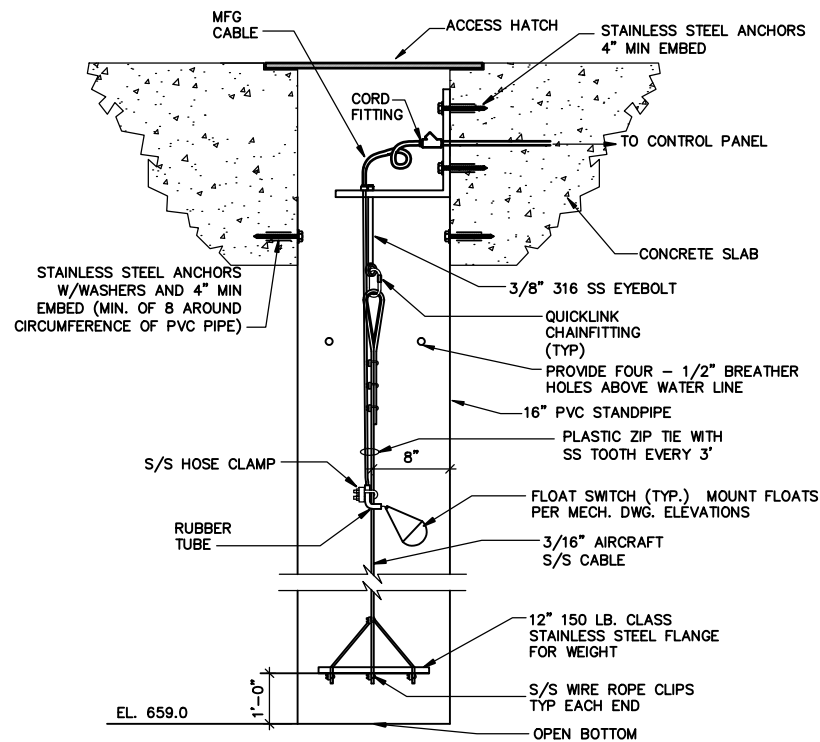

STILLING WELL MOUNTING DETAIL FOR WETWELL LEVEL SWITCHES

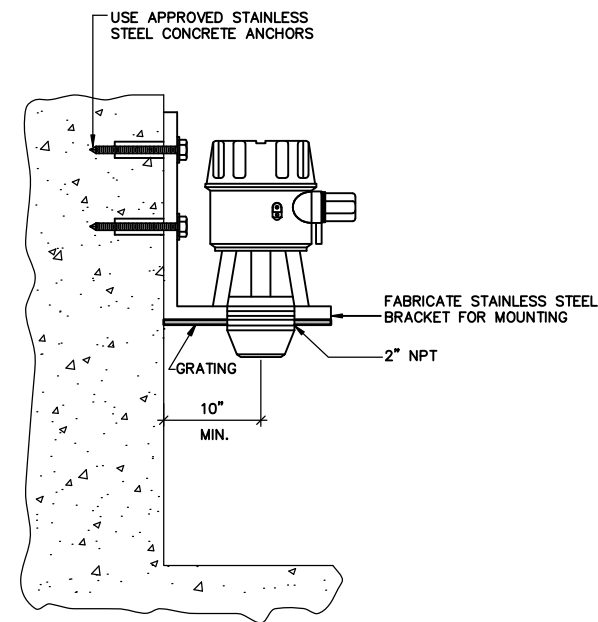

RECLAMATION SUMP ULTRASONIC MOUNTING DETAIL

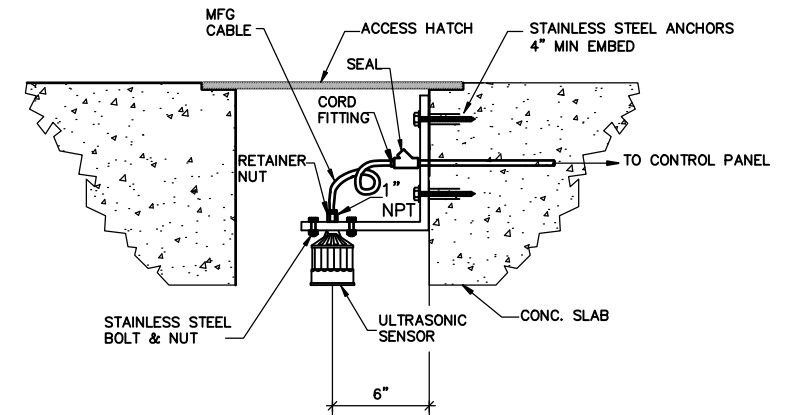

NOTE:  
1. ALL BRACKETS AND HARDWARE SHALL BE TYPE 316 STAINLESS STEEL.

WETWELL ULTRASONIC LEVEL SENSOR MOUNTING DETAIL

User: zomorodi; Spec: PIRNIE STANDARD; File: I:\CAD\PROJ\5324A701\DWG; Scale: 1:1; Date: 06/25/2009; Time: 11:47; Layout: GI-2



REVISIONS			
NO.	BY	DATE	REMARKS

DES SZ  
DWN SZ  
CKD EN

COVINA IRRIGATING COMPANY  
GLENORA, CALIFORNIA  
**UV/CHLORAMINES FOR TEMPLE WTP**

TEMPLE WATER TREATMENT PLANT  
**INSTRUMENTATION**  
**INSTALLATION DETAILS SHEET 1/2**  
NTS

COPYRIGHT © 2009  
MALCOLM PIRNIE, INC.  
DATE DECEMBER 2009  
GI SHEET 2 OF 3  
CAD REF. NO. 5324A701

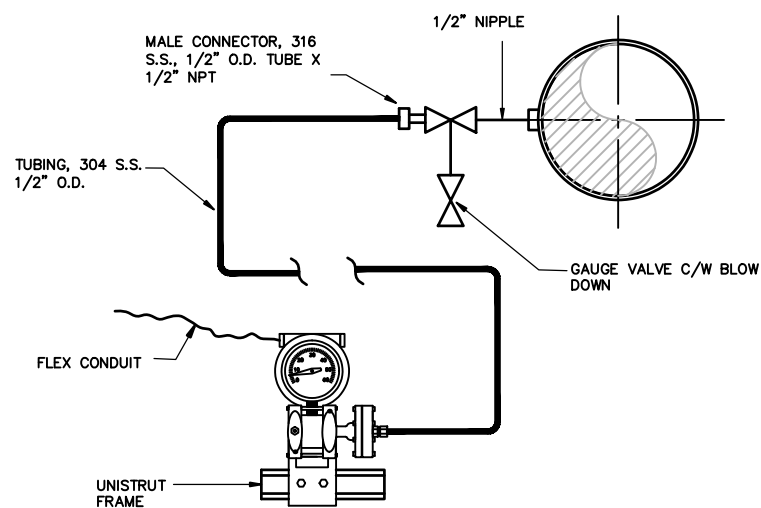

PRESSURE TRANSMITTER MOUNTING DETAIL

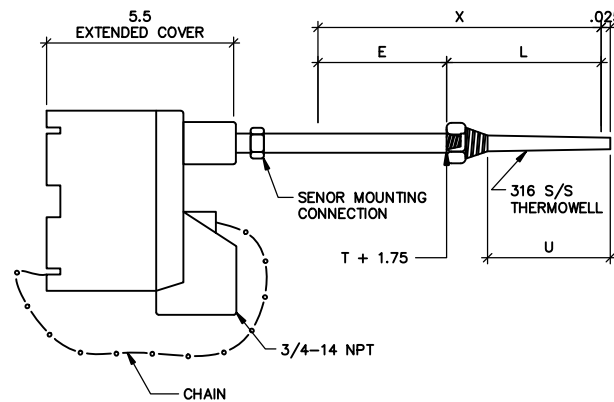

LENGTH CODE KEY	EQUATIONS
L THERMOWELL LENGTH MINUS 0.25 INCH.	$L = U + T + 1.5$
U IMMERSION LENGTH INTO PROCESS.	$X = E + L$
T LAGGING LENGTH.	$X = E + U + T + 1.5$
E EXTENSION FITTING LENGTH.	
X SENSOR LENGTH.	

RTD THERMOWELL AND TEMPERATURE TRANSMITTER INTEGRALLY MOUNTED

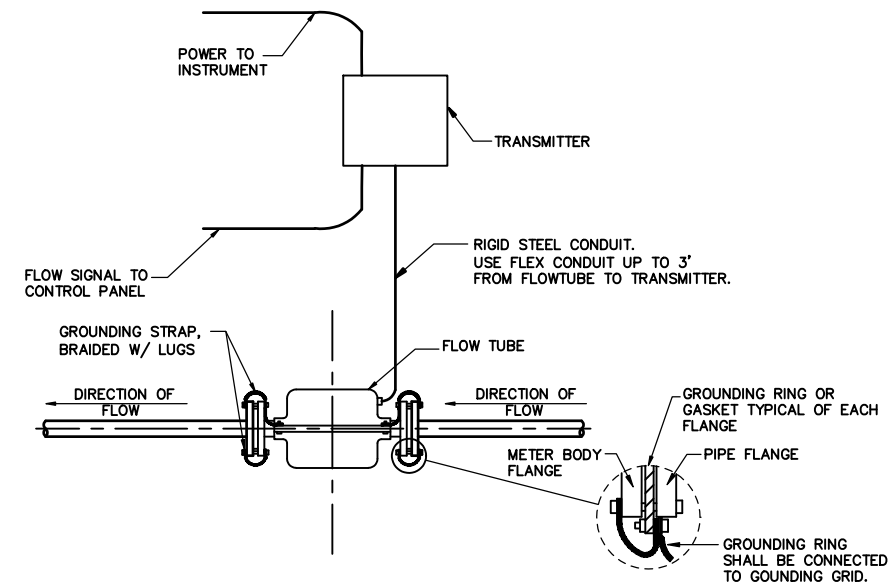

MAGNETIC FLOWMETER MOUNTING DETAIL

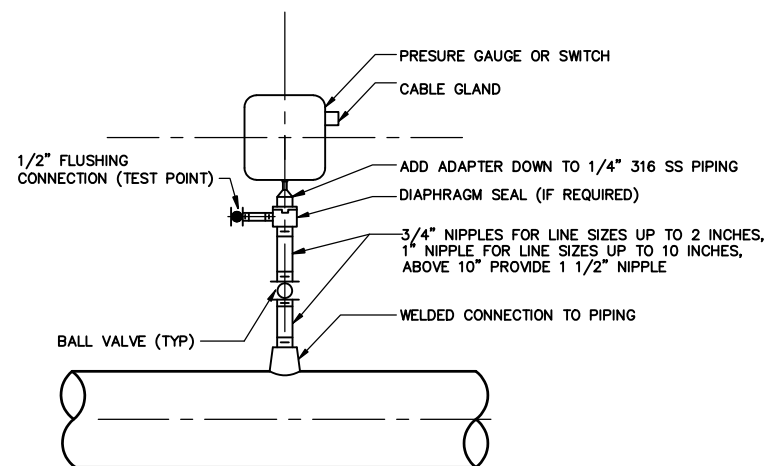

PRESSURE DEVICE WITH DIAPHRAM SEAL MOUNTING DETAILS

REVISIONS		NO.	BY	DATE	REMARKS
DES	SZ				
DWN	SZ				
CKD	EN				

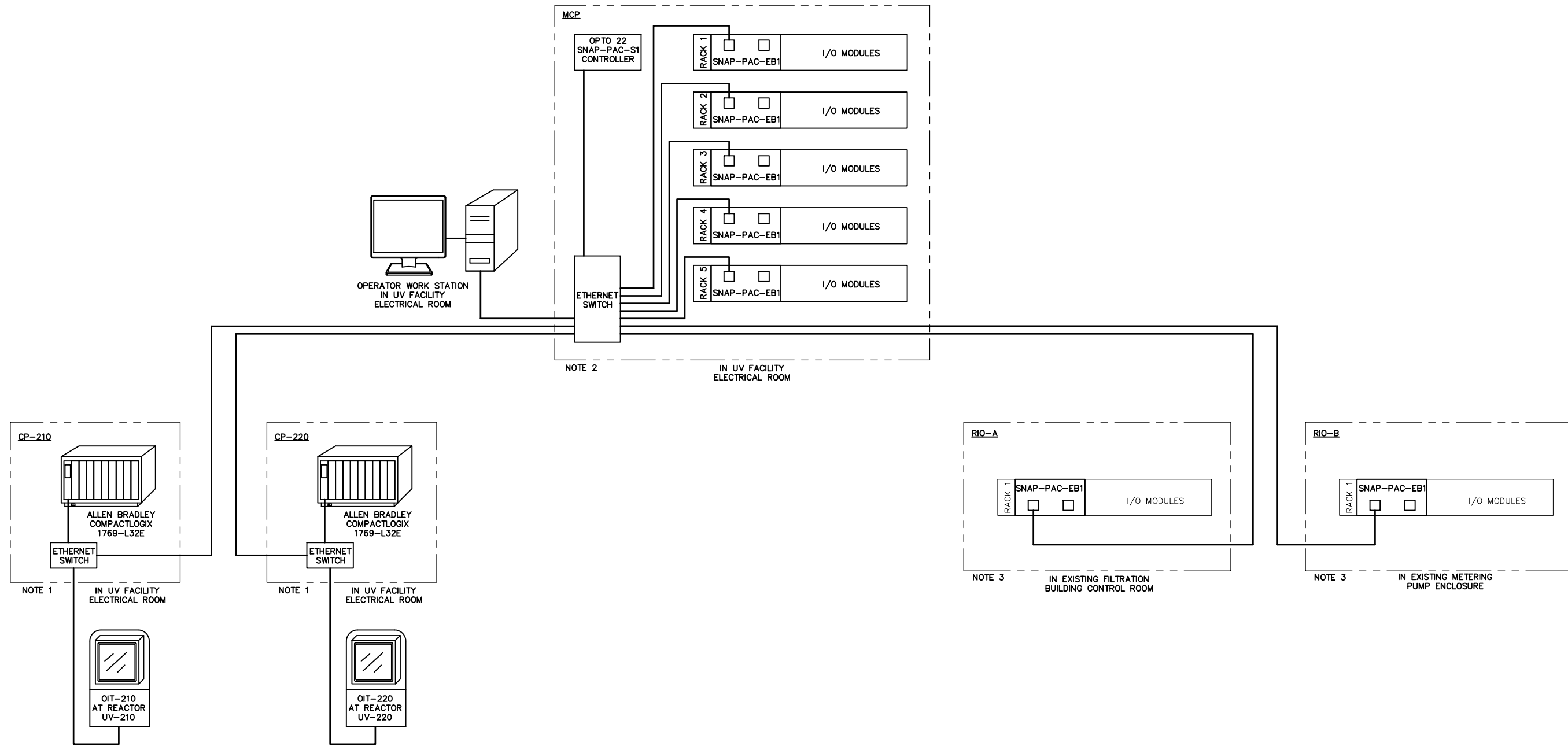

**NOTES**

1. FCP-210/220 AND OIT-210/220 COMPLETED WITH NETWORK EQUIPMENT WILL BE PROVIDED BY UV SYSTEM SUPPLIER (UVSS). SEE SPEC SECTION 11461 FOR HARDWARE REQUIREMENTS.
2. I/O RACKS SHALL BE CONFIGURED TO SUPPORT THE QUANTITY OF I/O SIGNALS SPECIFIED IN THE SPEC SECTIONS 13480, INPUT/OUTPUT LIST PLUS AN ADDITIONAL 20 PERCENT SPARE I/O AND PLC HARDWARE REQUIREMENTS SPECIFIED IN SPEC SECTION 13451. CONTRACTOR SHALL PROVIDE ALL NECESSARY HARDWARE AND SOFTWARE FOR A COMPLETE FUNCTIONAL CONTROL SYSTEM.
3. FURNISH AND INSTALL ETHERNET BRAIN SNAP-PAC-EB1 AT THE RIO-A AND RIO-B PANELS. SEE SPEC SECTION 13401.



REVISIONS		NO.	BY	DATE	REMARKS
DES	SZ				
DWN	SZ				
CKD	EN				

COVINA IRRIGATING COMPANY  
 GLENDORA, CALIFORNIA  
**UV/CHLORAMINES FOR TEMPLE WTP**

TEMPLE WATER TREATMENT PLANT  
**CONTROL SYSTEM  
 ARCHITECTURE**  
 NTS

COPYRIGHT © 2009  
 MALCOLM PIRNIE, INC.  
 DATE DECEMBER 2009  
 I SHEET 1 OF 9  
 CAD REF. NO. 5324A703

User: Zornocad; Spec: PIRNIE STANDARD; File: I:\ACAD\PROJ\5324002\_Covina\NSTR\5324A703.DWG - Scale: 1:1 Date: 06/26/2009 Time: 08:19 Layout: I-1



User: zomoradi; Spec: PIRNIE STANDARD; File: I:\ACAD\PROJ\5324A02\_Covina\NSTR\5324A704.DWG; Scale: 1:1; Date: 06/29/2009; Time: 14:41; Layout: 1-2

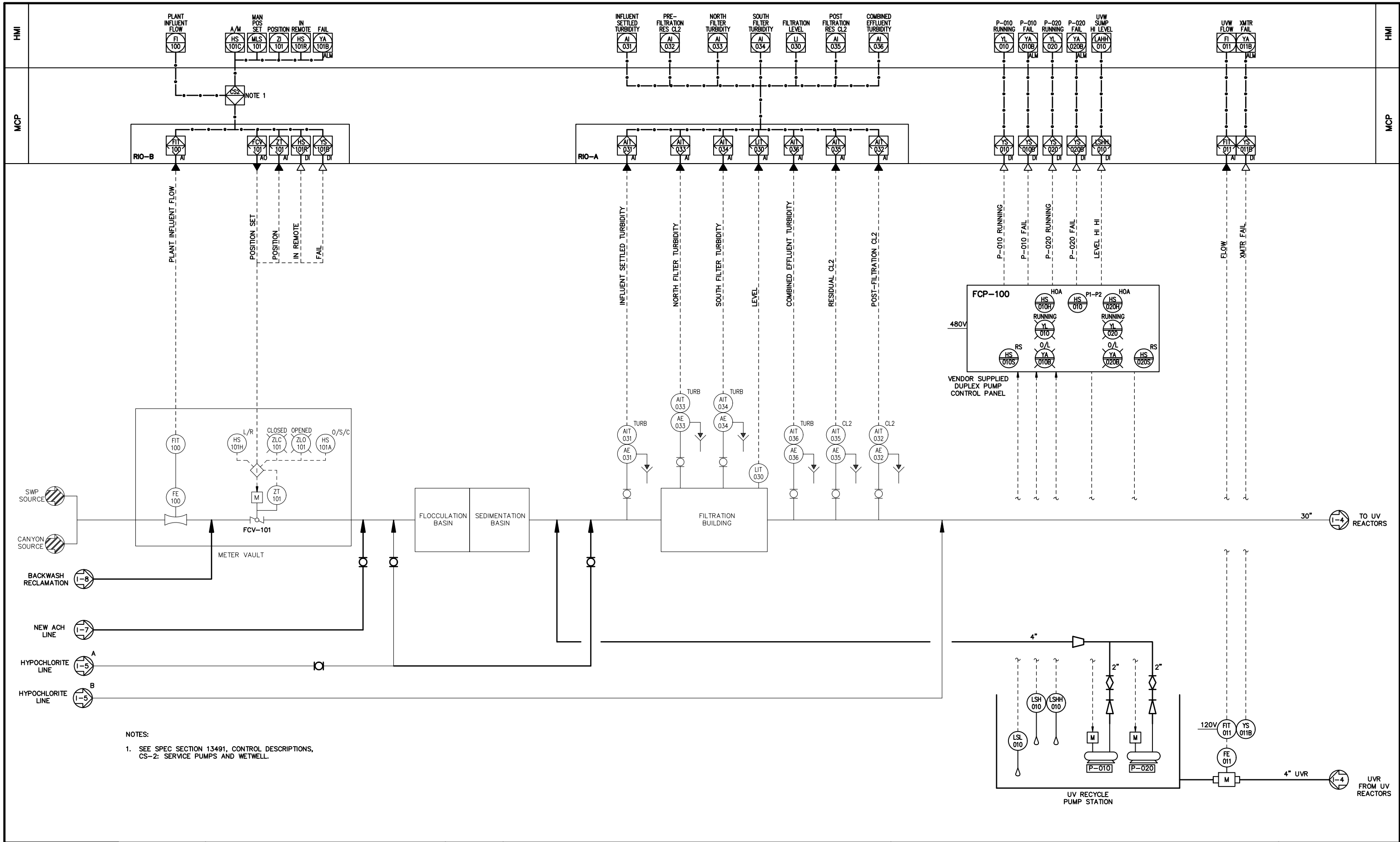

- NOTES:
- SEE SPEC SECTION 13491, CONTROL DESCRIPTIONS, CS-2: SERVICE PUMPS AND WETWELL.



REVISIONS			
NO.	BY	DATE	REMARKS

DES	SZ
DWN	SZ
CKD	EN

COVINA IRRIGATING COMPANY  
 GLENDORA, CALIFORNIA  
**UV/CHLORAMINES FOR TEMPLE WTP**

TEMPLE WATER TREATMENT PLANT  
**PLANT INFLUENT P&ID**  
 NTS

COPYRIGHT © 2009  
 MALCOLM PIRNIE, INC.  
 DATE: DECEMBER 2009  
 I SHEET 2 OF 9  
 CAD REF. NO. 5324A704

User: Zomorodi Spec: PIRNIE STANDARD File: I:\CAD\PROJ\5324A705.DWG Scale: 1:1 Date: 06/25/2009 Time: 18:44 Layout: 1-3

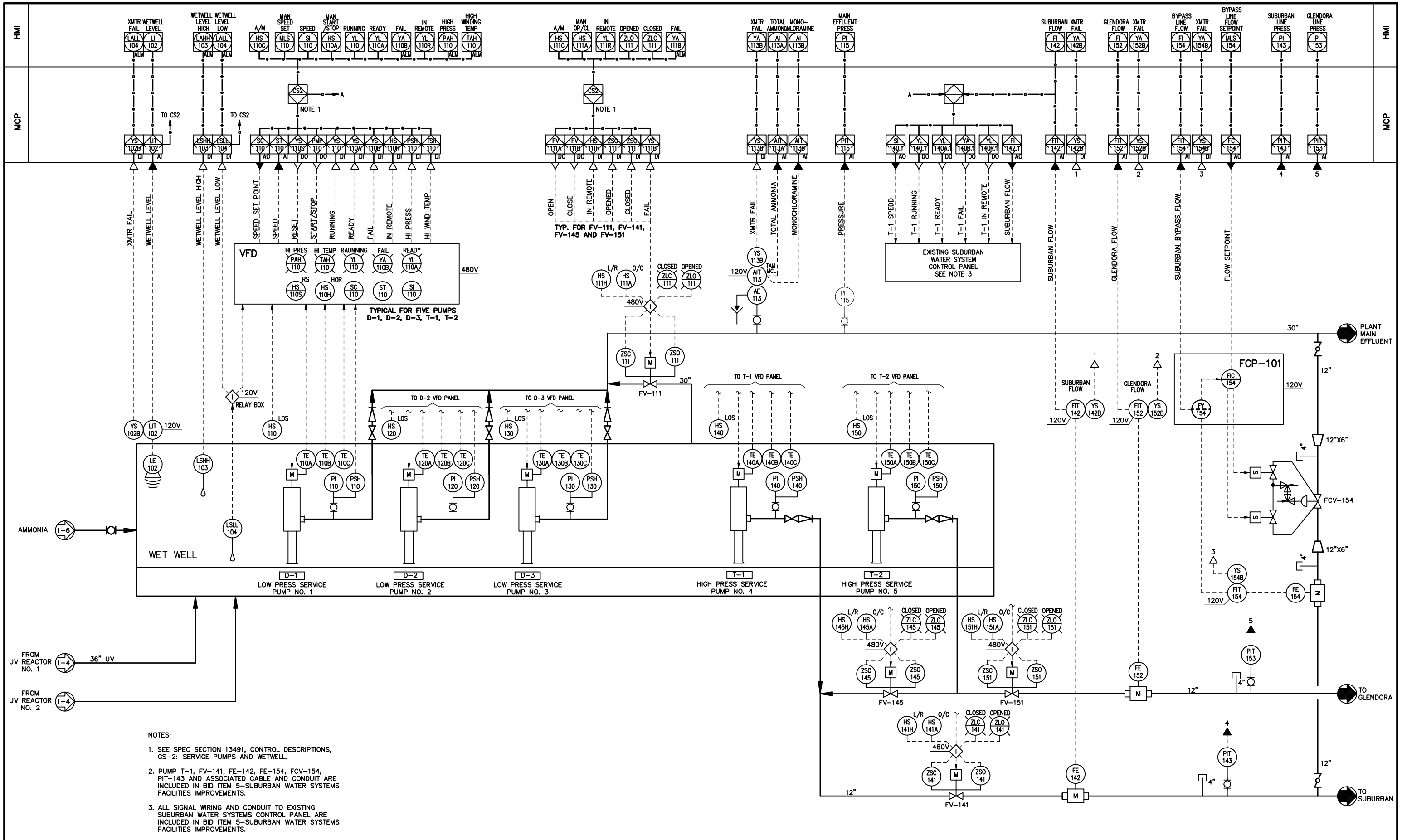

- NOTES:**
- SEE SPEC SECTION 13491, CONTROL DESCRIPTIONS, CS-2: SERVICE PUMPS AND WETWELL.
  - PUMP T-1, FV-141, FE-142, FE-154, FCV-154, PIT-143 AND ASSOCIATED CABLE AND CONDUIT ARE INCLUDED IN BID ITEM 5-SUBURBAN WATER SYSTEMS FACILITIES IMPROVEMENTS.
  - ALL SIGNAL WIRING AND CONDUIT TO EXISTING SUBURBAN WATER SYSTEMS CONTROL PANEL ARE INCLUDED IN BID ITEM 5-SUBURBAN WATER SYSTEMS FACILITIES IMPROVEMENTS.



REVISIONS			
NO.	BY	DATE	REMARKS

DES SZ  
DWN SZ  
CKD EN

COVINA IRRIGATING COMPANY  
GLENDDORA, CALIFORNIA  
**UV/CHLORAMINES FOR TEMPLE WTP**

TEMPLE WATER TREATMENT PLANT  
**SERVICE PUMPS**  
**P&ID**  
NTS

COPYRIGHT © 2009  
MALCOLM PIRNIE, INC.  
DATE DECEMBER 2009  
I SHEET 3 OF 9  
CAD REF. NO. 5324A705

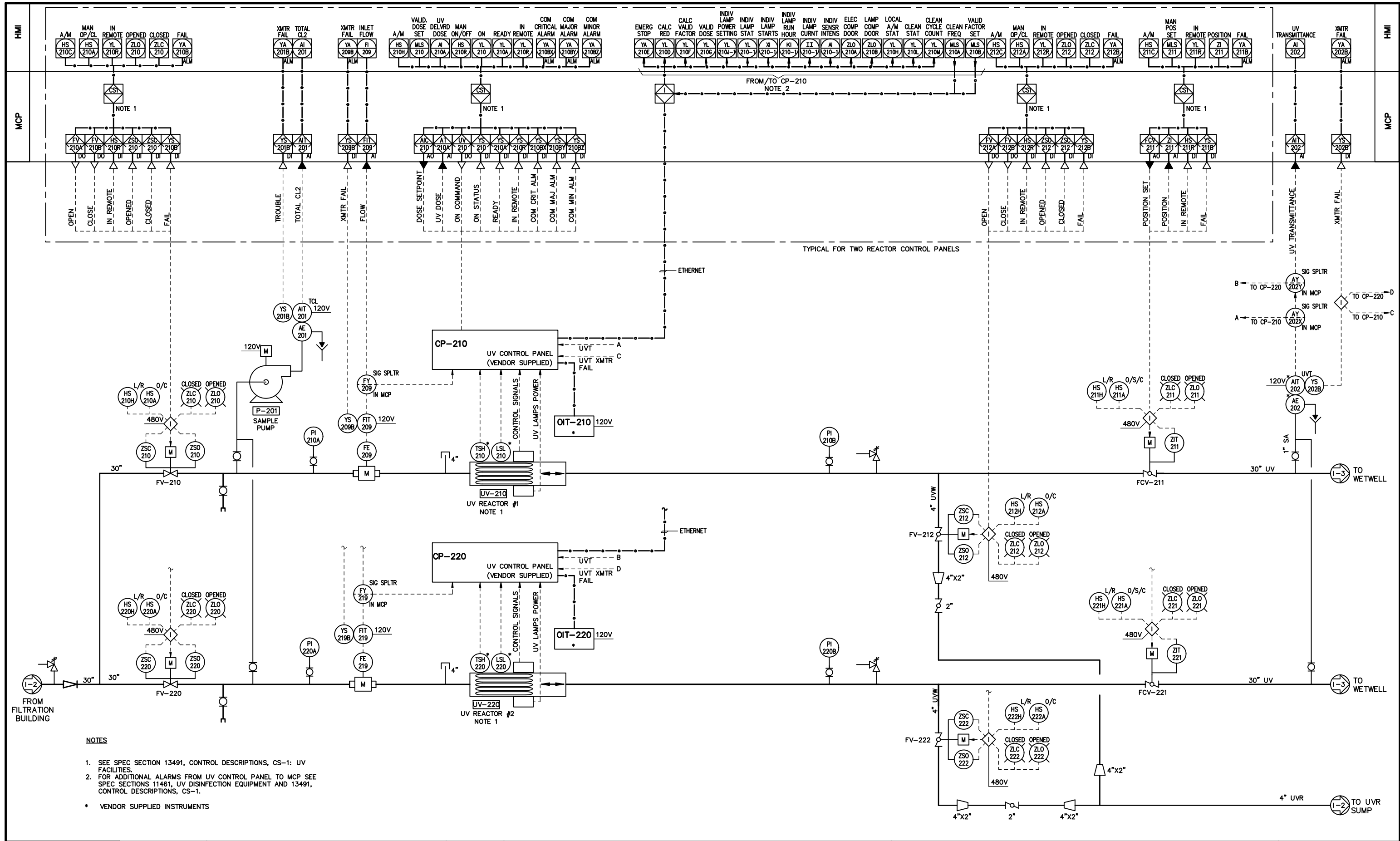

- NOTES**
- SEE SPEC SECTION 13491, CONTROL DESCRIPTIONS, CS-1: UV FACILITIES.
  - FOR ADDITIONAL ALARMS FROM UV CONTROL PANEL TO MCP SEE SPEC SECTIONS 11461, UV DISINFECTION EQUIPMENT AND 13491, CONTROL DESCRIPTIONS, CS-1.
- \* VENDOR SUPPLIED INSTRUMENTS



REVISIONS			
NO.	BY	DATE	REMARKS

DES SZ  
DWN SZ  
CKD EN

COVINA IRRIGATING COMPANY  
GLENORA, CALIFORNIA  
**UV/CHLORAMINES FOR TEMPLE WTP**

TEMPLE WATER TREATMENT PLANT  
**UV FACILITIES**  
P&ID  
NTS

COPYRIGHT © 2009  
MALCOLM PIRNIE, INC.  
DATE DECEMBER 2009  
I SHEET 4 OF 9  
CAD REF. NO. 5324A706

User: Zomarcodi; Spec: PIRNIE STANDARD; File: I:\ACAD\PROJ\5324A706.DWG; Scale: 1:1; Date: 06/25/2009; Time: 18:32; Layout: 1-4

User: zomoradi; Spec: PIRNIE; STANDARD; File: I:\CAD\PROJ\5324A002\_Covina\NSTR\5324A707.DWG; Scale: 1:1; Date: 06/29/2009; Time: 15:31; Layout: 1-5

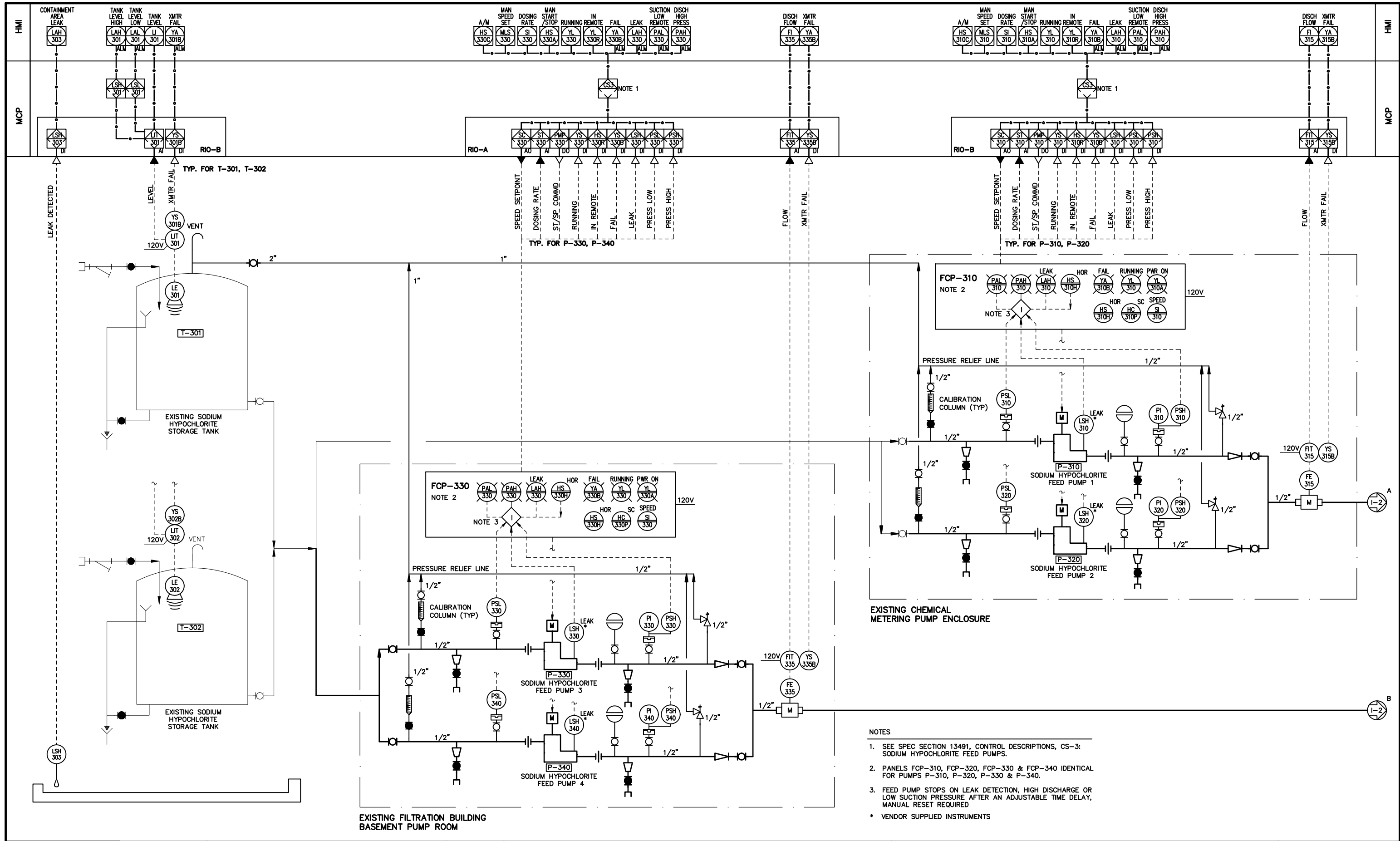

- NOTES**
- SEE SPEC SECTION 13491, CONTROL DESCRIPTIONS, CS-3: SODIUM HYPOCHLORITE FEED PUMPS.
  - PANELS FCP-310, FCP-320, FCP-330 & FCP-340 IDENTICAL FOR PUMPS P-310, P-320, P-330 & P-340.
  - FEED PUMP STOPS ON LEAK DETECTION, HIGH DISCHARGE OR LOW SUCTION PRESSURE AFTER AN ADJUSTABLE TIME DELAY, MANUAL RESET REQUIRED
- \* VENDOR SUPPLIED INSTRUMENTS



REVISIONS			
NO.	BY	DATE	REMARKS

DES SZ  
DWN SZ  
CKD EN

COVINA IRRIGATING COMPANY  
GLENORA, CALIFORNIA  
**UV/CHLORAMINES FOR TEMPLE WTP**

TEMPLE WATER TREATMENT PLANT  
**SODIUM HYPOCHLORITE STORAGE AND FEED P&ID**  
NTS

COPYRIGHT © 2009  
MALCOLM PIRNIE, INC.  
DATE: DECEMBER 2009  
I SHEET 5 OF 9  
CAD REF. NO. 5324A707

User:Zamoradi Spec:PIRNF STANDARD File:I:\CAD\PROJ\5324A708\DWG Scale:1:1 Date:06/25/2009 Time:16:46 Layout:1-6

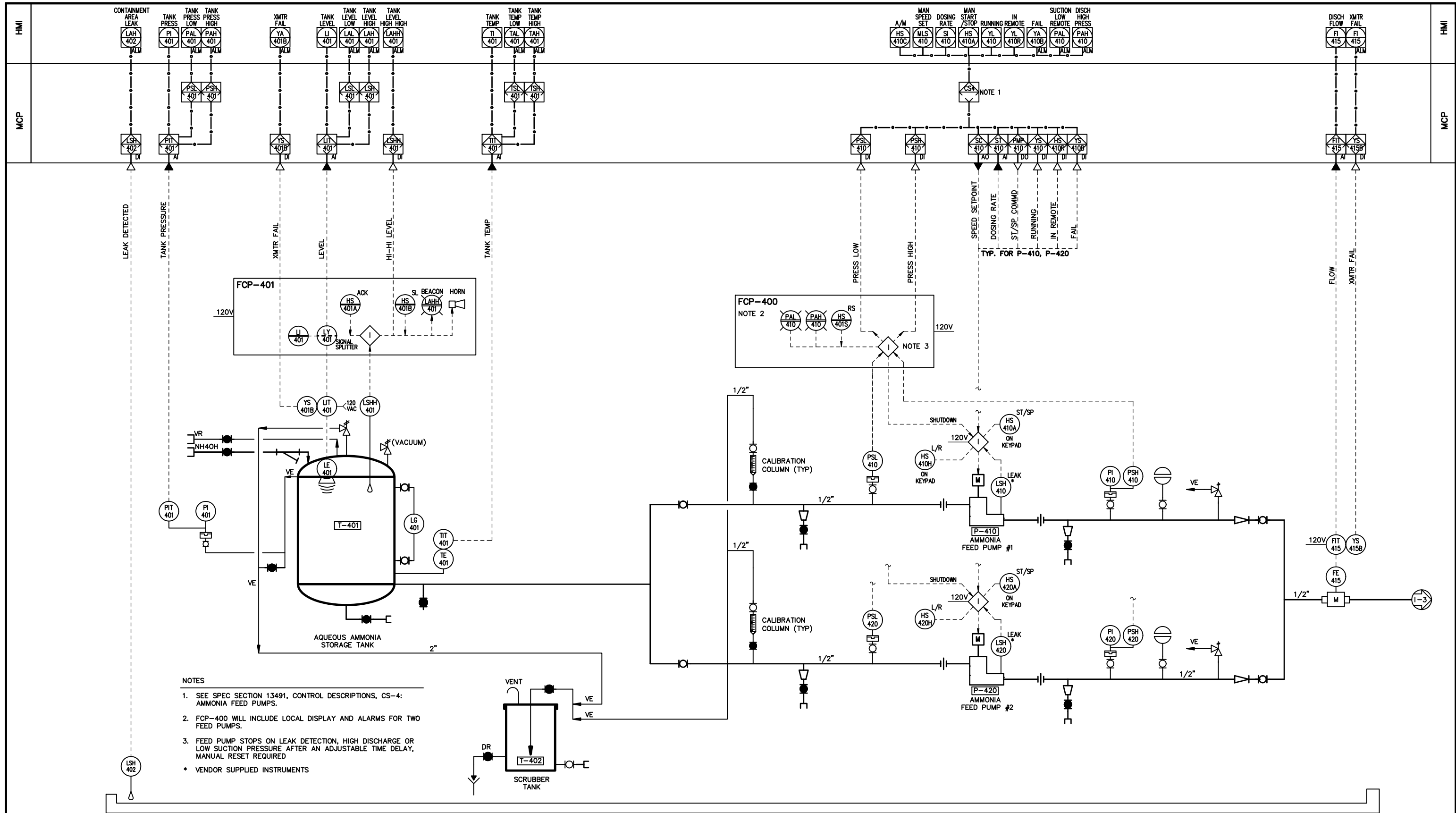

- NOTES**
- SEE SPEC SECTION 13491, CONTROL DESCRIPTIONS, CS-4: AMMONIA FEED PUMPS.
  - FCP-400 WILL INCLUDE LOCAL DISPLAY AND ALARMS FOR TWO FEED PUMPS.
  - FEED PUMP STOPS ON LEAK DETECTION, HIGH DISCHARGE OR LOW SUCTION PRESSURE AFTER AN ADJUSTABLE TIME DELAY, MANUAL RESET REQUIRED
- \* VENDOR SUPPLIED INSTRUMENTS



REVISIONS			
NO.	BY	DATE	REMARKS

DES SZ  
DWN SZ  
CKD EN

COVINA IRRIGATING COMPANY  
GLENDDORA, CALIFORNIA  
**UV/CHLORAMINES FOR TEMPLE WTP**

TEMPLE WATER TREATMENT PLANT  
**AQUEOUS AMMONIA STORAGE AND FEED P&ID**  
NTS

COPYRIGHT © 2009  
MALCOLM PIRNIE, INC.  
DATE DECEMBER 2009  
I SHEET 6 OF 9  
CAD REF. NO. 5324A708

User: zomorodi Spec: PIRNIE STANDARD File: I:\ACAD\PROJ\5324A709.DWG Scale: 1:1 Date: 06/25/2009 Time: 16:55 Layout: 1-7

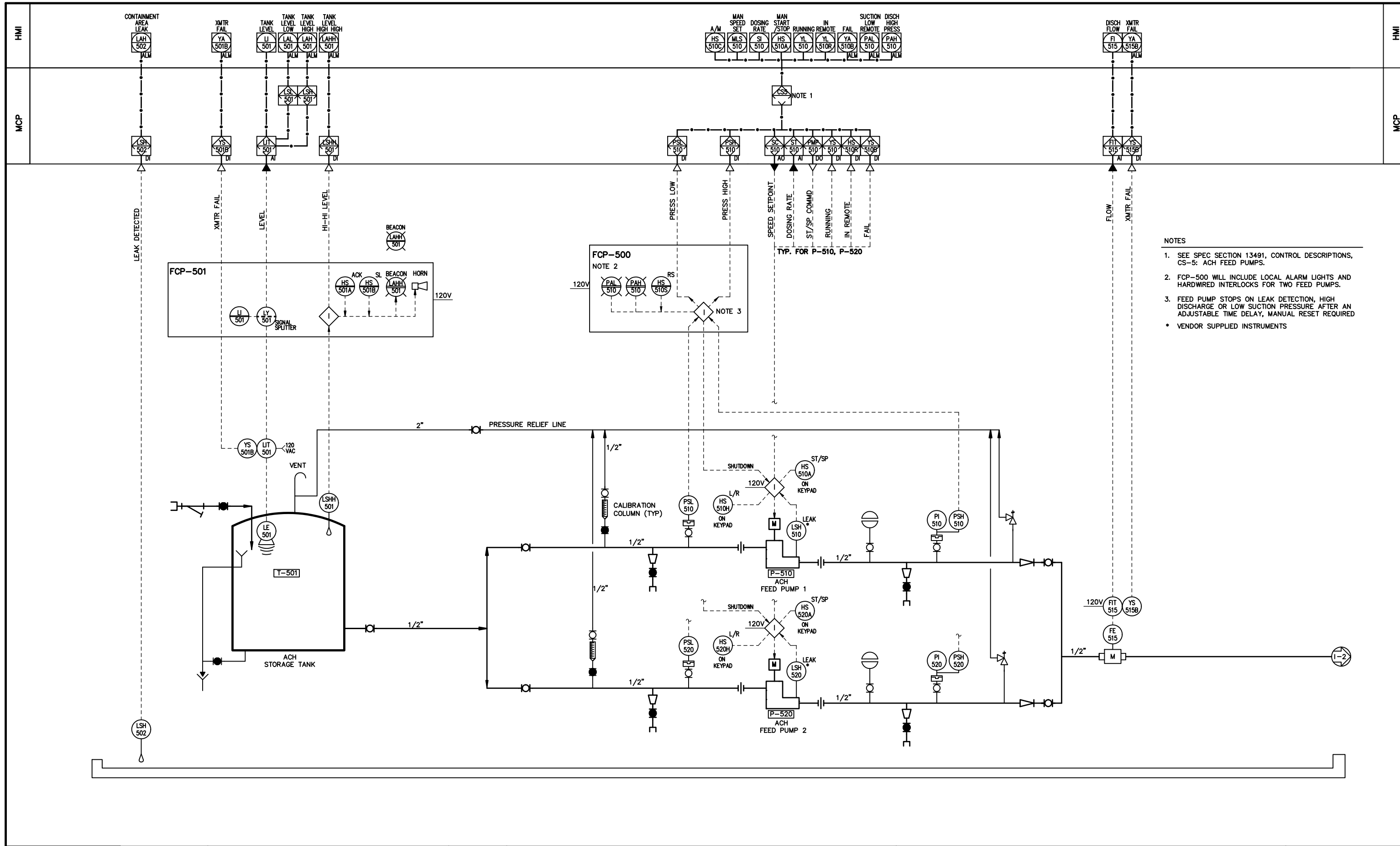

- NOTES
- SEE SPEC SECTION 13491, CONTROL DESCRIPTIONS, CS-5: ACH FEED PUMPS.
  - FCP-500 WILL INCLUDE LOCAL ALARM LIGHTS AND HARDWIRED INTERLOCKS FOR TWO FEED PUMPS.
  - FEED PUMP STOPS ON LEAK DETECTION, HIGH DISCHARGE OR LOW SUCTION PRESSURE AFTER AN ADJUSTABLE TIME DELAY, MANUAL RESET REQUIRED
- \* VENDOR SUPPLIED INSTRUMENTS



REVISIONS			
NO.	BY	DATE	REMARKS

DES SZ  
DWN SZ  
CKD EN

COVINA IRRIGATING COMPANY  
GLENORA, CALIFORNIA  
**UV/CHLORAMINES FOR TEMPLE WTP**

TEMPLE WATER TREATMENT PLANT  
**ACH STORAGE AND FEED P&ID**  
NTS

COPYRIGHT © 2009  
MALCOLM PIRNIE, INC.  
DATE DECEMBER 2009  
I SHEET 7 OF 9  
CAD REF. NO. 5324A709

User:Zamoradi Spec:PIRNF STANDARD File:I:\ACAD\PROJ\5324A710.DWG Scale:1:1 Date:06/29/2009 Time:17:19 Layout:1-8

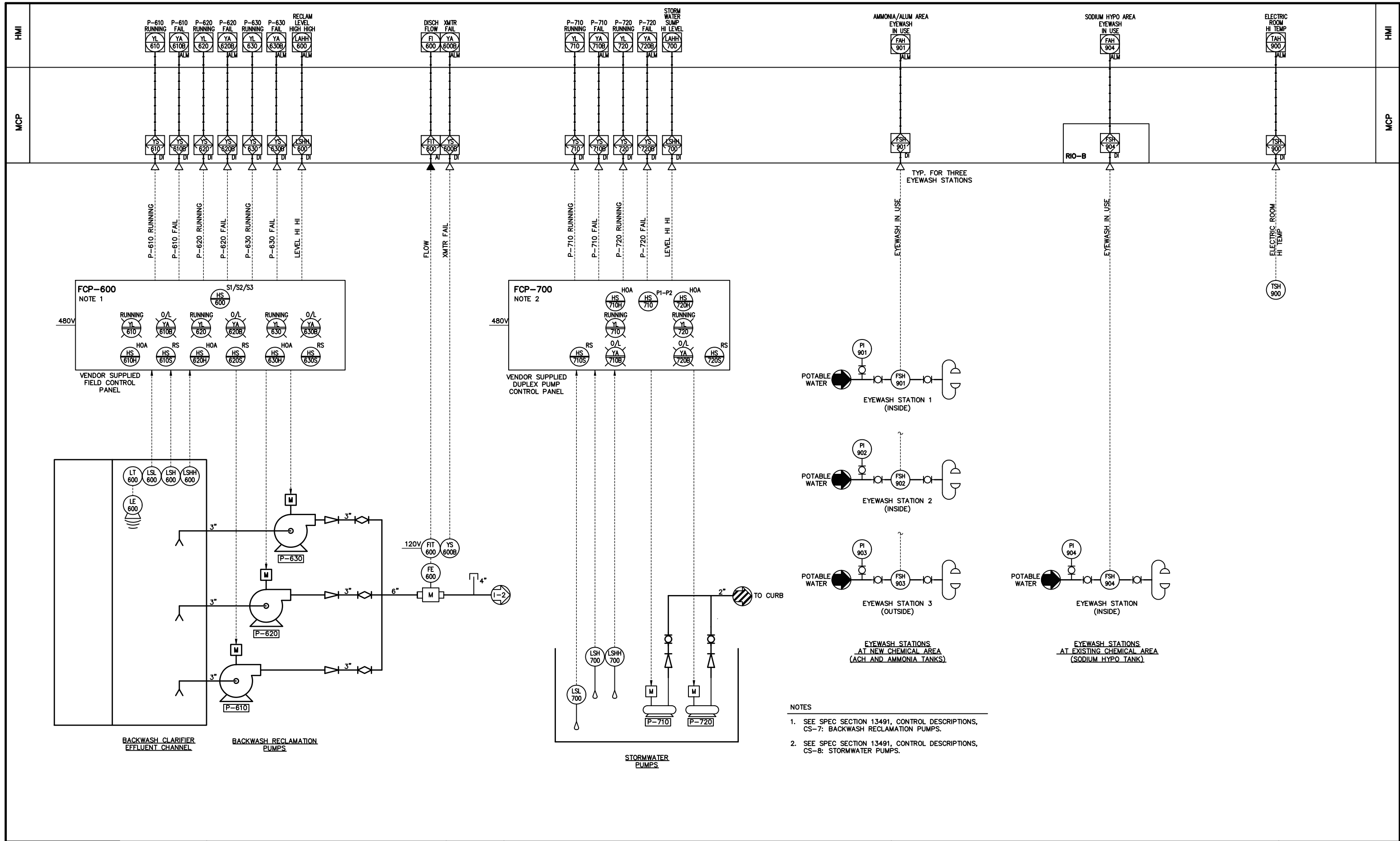

- NOTES**
- SEE SPEC SECTION 13491, CONTROL DESCRIPTIONS, CS-7: BACKWASH RECLAMATION PUMPS.
  - SEE SPEC SECTION 13491, CONTROL DESCRIPTIONS, CS-8: STORMWATER PUMPS.



REVISIONS			
NO.	BY	DATE	REMARKS

DES SZ  
DWN SZ  
CKD EN

COVINA IRRIGATING COMPANY  
GLENORA, CALIFORNIA  
**UV/CHLORAMINES FOR TEMPLE WTP**

TEMPLE WATER TREATMENT PLANT  
**MISCELLANEOUS P&ID**  
NTS

COPYRIGHT © 2009  
MALCOLM PIRNIE, INC.  
DATE DECEMBER 2009  
I SHEET 8 OF 9  
CAD REF. NO. 5324A710

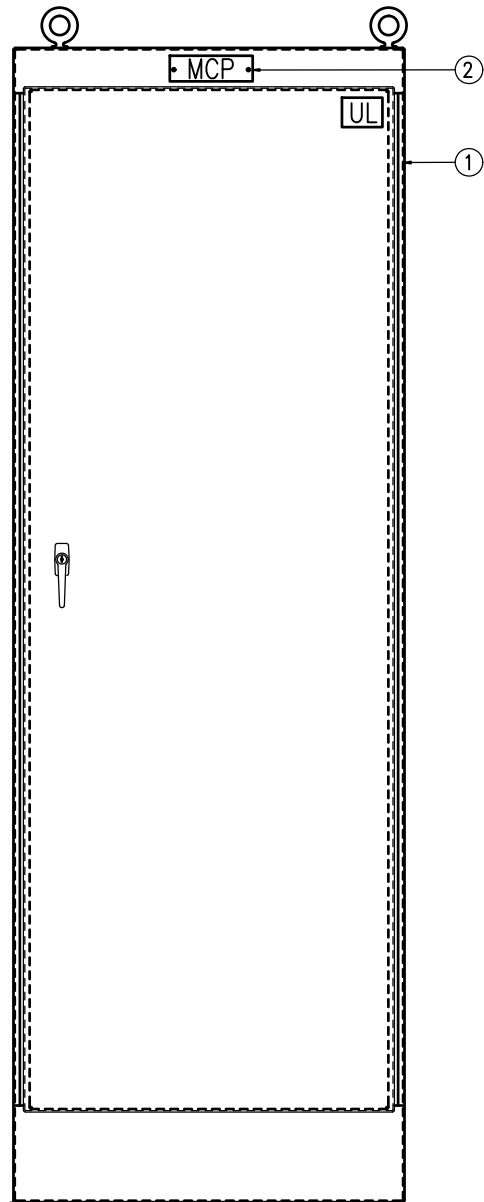

FRONT VIEW  
NTS

TAG	QTY	MATERIAL LIST
①	1	FREE STANDING ENCLOSURE, NEMA 12, 1 DOOR, 3-PT LATCH
②	1	ENGRAVED NAMEPLATE
③	LOT	UL LABELS FOR UL-508, UL-508A & UL-698A

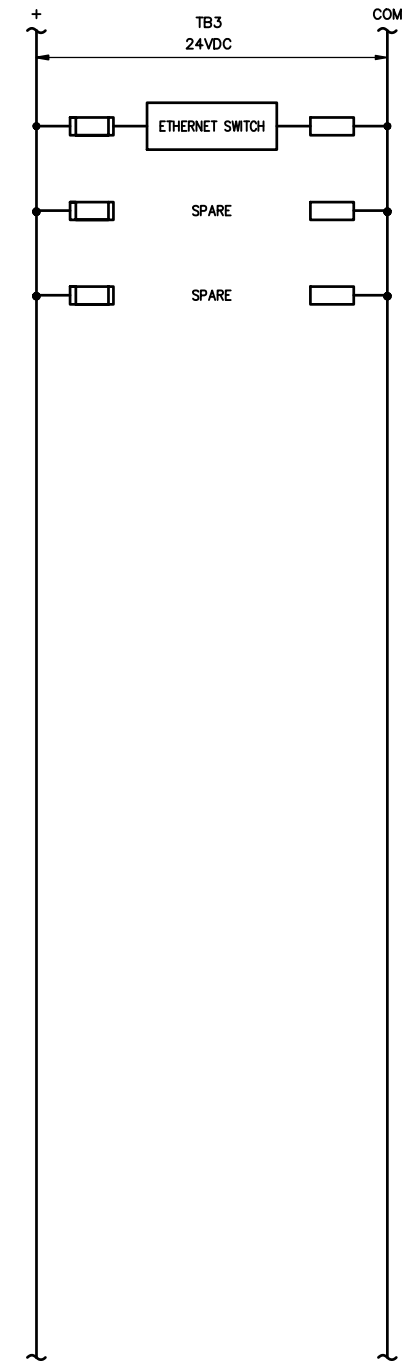
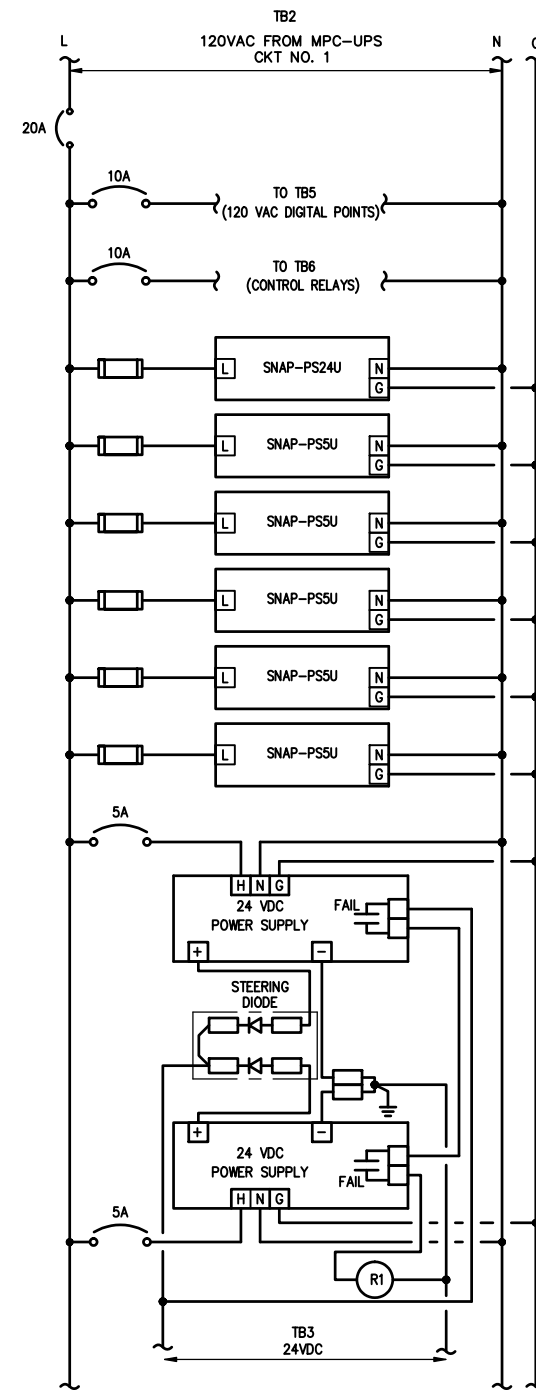
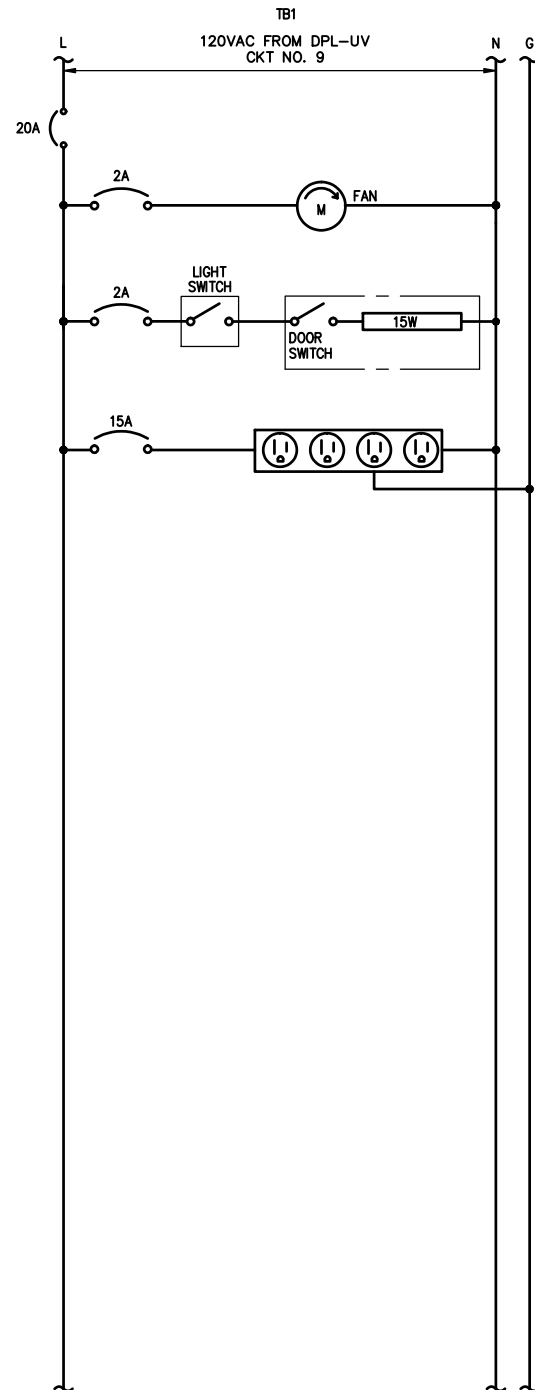

NOTES

- I/O MODULES WIRING ARE NOT SHOWN. REFER TO SPEC SECTION 13451, ATTACHMENT A, I/O LIST PANEL I/O POINTS.
- 24 VDC FAIL RELAY CONTACT SHALL BE CONNECTED TO THE PLC INPUT CARD. SEE SPEC SECTION 13451, ATTACHMENT A , I/O LIST.

MALCOLM  
PIRNIE



REVISIONS		NO.	BY	DATE	REMARKS
DES	SZ				
DWN	SZ				
CKD	EN				

COVINA IRRIGATING COMPANY  
GLENORA, CALIFORNIA  
**UV/CHLORAMINES FOR TEMPLE WTP**

TEMPLE WATER TREATMENT PLANT  
**MCP PANEL LAYOUT AND  
POWER DISTRIBUTION**  
NTS

COPYRIGHT © 2009  
MALCOLM PIRNIE, INC.  
DATE DECEMBER 2009  
I-9 SHEET 9 OF 9  
CAD REF. NO. 5324A711

User:Stratona Spec:PIRNIE STANDARD File: \\VACAD\PROJ\5324002 Covina\INSTR\5324A700.DWG Scale: 1:1 Date: 03/27/2009 Time: 08:43 Layout: 1-1



**GEOTECHNICAL EVALUATION  
COVINA IRRIGATION COMPANY  
225 WEST ARROW HIGHWAY  
GLENORA, CALIFORNIA**

**PREPARED FOR:**

Malcolm Pirnie, Inc.  
8001 Irvine Center Drive, Suite 1100  
Irvine, California 92618

**PREPARED BY:**

Ninyo & Moore  
Geotechnical and Environmental Sciences Consultants  
475 Goddard, Suite 200  
Irvine, California 92618

December 3, 2007  
Project No. 207296001

December 3, 2007  
Project No. 207296001

Mr. Gregory S. Bazydola  
Malcolm Pirnie  
8001 Irvine Center Drive, Suite 1100  
Irvine, California 92618-2989

Subject: Geotechnical Evaluation  
Covina Irrigation Company  
225 West Arrow Highway  
Glendora, California

Dear Mr. Bazydola:

In accordance with your request and authorization, we have performed a geotechnical evaluation for the proposed improvements at the existing Covina Irrigation Company, located at 225 West Arrow Highway in Glendora, California. This report describes the geological and geotechnical conditions in the area of the proposed construction and presents our conclusions and recommendations regarding the design and construction of the proposed improvements.

We appreciate the opportunity to be of service on this project.

Respectfully submitted,  
**NINYO & MOORE**



James J. Barton, C.E.G.  
Senior Geologist



Jalal Vakili, Ph.D., P.E.  
Principal Engineer

JJB/CAP/DC/JV/emp

Distribution: (4) Addressee



Daniel Chu, Ph.D., G.E.  
Chief Geotechnical Engineer



---

## TABLE OF CONTENTS

	<u>Page</u>
1. INTRODUCTION .....	1
2. SCOPE OF SERVICES .....	1
3. SITE DESCRIPTION .....	2
4. PROPOSED CONSTRUCTION .....	3
5. SUBSURFACE EXPLORATION AND LABORATORY TESTING .....	3
6. GEOLOGIC AND SUBSURFACE CONDITIONS .....	4
6.1. Regional Geologic Setting .....	4
6.2. Site Geology .....	4
6.3. Groundwater .....	5
7. FAULTING AND SEISMICITY .....	5
7.1. Ground Motion .....	6
7.2. Surface Fault Rupture .....	7
7.3. Liquefaction and Dynamic Settlement .....	8
8. CONCLUSIONS .....	8
9. RECOMMENDATIONS .....	9
9.1. Earthwork .....	9
9.1.1. Pre-Construction Conference .....	10
9.1.2. Site Preparation .....	10
9.1.3. Overexcavation for Improvements .....	10
9.1.4. Fill Material .....	11
9.1.5. Fill Placement and Compaction .....	11
9.1.6. Excavation Characteristics .....	12
9.1.7. Temporary Construction and Trench Excavations .....	12
9.1.8. Trench Backfill .....	13
9.2. Seismic Design Considerations .....	13
9.3. Foundations .....	14
9.3.1. Mat Foundation .....	14
9.3.2. Shallow Footings .....	15
9.4. Concrete Placement .....	16
9.5. Concrete Type .....	16
9.6. Corrosivity .....	16
9.7. Pavement Design .....	17
9.8. Surface Drainage .....	18
9.9. Construction Observation .....	18
10. LIMITATIONS .....	19

11. SELECTED REFERENCES .....21

**Tables**

Table 1 – Principal Active Faults .....6  
Table 2 – 1997 Uniform Building Code Seismic Recommendations .....14  
Table 3 – Preliminary Structural Pavement Sections .....17

**Figures**

Figure 1 – Site Location Map  
Figure 2 – Boring Location Map  
Figure 3 – Regional Geologic Map  
Figure 4 – Fault Location Map

**Appendices**

Appendix A – Boring Logs  
Appendix B – Laboratory Testing

## 1. INTRODUCTION

In accordance with your request and our proposal dated October 8, 2007, we have performed a geotechnical evaluation for the proposed improvements at the existing Covina Irrigation Plant in Glendora, California (Figure 1). The purpose of our study was to evaluate the subsurface soil and geologic conditions at the site and to prepare geotechnical recommendations for the project. This report presents our findings, conclusions, and recommendations based on our background review, site reconnaissance, subsurface evaluation, laboratory testing, and geotechnical analyses.

## 2. SCOPE OF SERVICES

Our scope of services for this evaluation included the following:

- Review of readily available background materials, including State of California Seismic Hazards Zones maps, State of California Earthquake Fault Zone maps (Alquist-Priolo Special Studies Zones maps), other published geologic maps and literature, in-house information, stereoscopic aerial photographs, and plans provided by the client.
- Performance of a site reconnaissance to observe the existing conditions at the site and to mark the proposed boring locations for utility clearance. Mark-out of potential existing underground utilities was conducted through Underground Service Alert (USA).
- Assessment of the general geologic conditions and seismic hazards affecting the area and evaluation of their potential impacts on the project.
- Subsurface evaluation consisting of the excavation, logging, and sampling of two small-diameter borings to depths of up to approximately 51½ feet. The borings were logged by a representative of our firm. Bulk and relatively undisturbed soil samples were collected at selected intervals for laboratory testing.
- Laboratory testing of selected samples obtained to evaluate in-situ moisture and dry density, maximum dry density, gradation, shear strength, and soil corrosivity of the on-site soils.
- Compilation and geotechnical analysis of background, field and laboratory data, including analyses to evaluate and provide recommendations for the following:
  - Suitability of the site for the proposed improvements from a geotechnical perspective.
  - Description of the site geology and on-site soils anticipated during construction, including an evaluation of geologic hazards that might be present at the site.

- Review of site seismicity to provide design parameters, including the soil profile type, the distance to faults, the fault type, and the seismic coefficient per the California Building Code.
  - Excavatibility of the on-site materials.
  - Excavation and compaction requirements, including suitability of the on-site soils for reuse as fill material.
  - Evaluation of the corrosion potential of on-site soils.
  - Geotechnical engineering to evaluate appropriate foundation types for the proposed structure, including allowable bearing capacity, passive pressure, and anticipated total and differential settlement.
- Preparation of this report to present our findings, conclusions, and recommendations pertaining to the design and construction of the proposed improvements.

### **3. SITE DESCRIPTION**

The existing Covina Irrigation Plant consists of a rectangular-shaped parcel located north of West Arrow Highway and south of the San Dimas Wash within a mixed industrial and residential area of Glendora, California (Figure 1). The property is situated east of Grand Avenue and west of Glendora Avenue on a relatively flat graded lot. The site latitude and longitude are 33.106670 degrees north and -117.867460 degrees west, respectively (Google Earth Pro, 2007). Topographically, the site slopes gently to the south-southwest with elevations ranging from approximately 675 to 670 feet above mean sea level (MSL) (United States Geological Survey [USGS], 1981).

The site is currently in use predominantly as a water treatment plant. This plant consists of an operations and filter building spanning the central portion of the site with flocculation and settling basins located in the eastern portion of the site. The western portion of the site, approximately 75 by 75 feet, is fenced off from the rest of the property and is currently in use as a storage yard for an automobile and bus repair business.

The proposed improvements will be situated in the central portion of the site south of the operations and filter building as well as in the western portion of the site. The site is currently

paved with asphalt concrete, with some vegetation within planters located along the operations and filter building. Existing pavements and Arrow Highway border the east, west, and south sides of the property. The north side of the property is bordered by a relatively narrow, concrete-lined, storm drain box channel (San Dimas Wash) approximately 10 feet deep. Chain-link fences are present along the top of the channel.

#### **4. PROPOSED CONSTRUCTION**

We understand that the proposed improvements will include a new concrete masonry slab-on-grade structure on the south side of the existing operations and filter building. Currently, plans are not available regarding the new improvements. The plan dimension of this new structure, however, is expected to be approximately 20 feet by 40 feet, and it will contain a relatively small generator on the side of the building. The proposed structure will house equipment for water treatment. No significant foundation loads are expected. In addition, an ammonia storage tank may be located west of the plant within the current auto storage yard. Grading to attain the desired finish grade elevations are expected to be relatively minor with cuts and fills of less than approximately 3 feet.

#### **5. SUBSURFACE EXPLORATION AND LABORATORY TESTING**

Our subsurface evaluation was conducted on October 30, 2007, and included the drilling, logging, and sampling of two small-diameter borings. The borings were drilled with a truck-mounted drill rig utilizing 8-inch-diameter, hollow-stem augers. The borings were drilled to a depth of approximately 51½ feet for boring B-1 and 50½ feet for boring B-2 and were logged by a representative from our firm. Representative disturbed and undisturbed soil samples were obtained at selected depths for laboratory testing. The approximate locations of the borings are presented on Figure 2. The boring logs are presented in Appendix A.

Laboratory testing of representative soil samples included evaluation of in-situ moisture and dry density, Proctor density, gradation, shear strength, and soil corrosivity. Laboratory test results are

presented on the logs in Appendix A and in the summary of laboratory test results presented in Appendix B.

## **6. GEOLOGIC AND SUBSURFACE CONDITIONS**

### **6.1. Regional Geologic Setting**

The subject site is located within the northeastern portion of the Los Angeles Basin, which is included in the Peninsular Ranges Geomorphic Province (Norris and Webb, 1990). The geomorphic province encompasses an area that extends approximately 125 miles from the Transverse Ranges and the Los Angeles Basin south to the Mexican border, and continues further to the tip of Baja California. The Los Angeles Basin has been divided into four structural blocks which are generally bounded by prominent fault systems. The site is located within the Northeastern Block, which is bordered on the west and south by the Whittier-Elsinore fault and is bordered on the north by the San Gabriel Mountains and the Raymond Hill Fault. The Northeastern Block is a deep basin characterized by thick sequences of alluvium and sedimentary units overlying basement rocks, which are at depths of up to approximately 12,000 feet below the surface in the central part of the San Gabriel Valley.

### **6.2. Site Geology**

Our review of the referenced geologic maps and literature indicates that the subject site is underlain by Holocene to Pleistocene alluvial gravel and sand (Dibblee, 2002) (Figure 3). Earth materials encountered during our subsurface exploration at the site generally consisted of relatively shallow fill soils overlying alluvium. In boring B-1, asphalt concrete (approximately 4½ inches) and an older layer of concrete (approximately 3 to 4 inches) and aggregate base extended to a depth of approximately 2 feet below the existing ground surface. The pavement section was underlain by fill soils to a depth of approximately 5 feet. In boring B-2, fill soils were encountered beneath the asphalt concrete pavement to a depth of approximately 2 feet. The fill material generally consisted of medium dense, silty



sand with gravel and poorly graded sand. The fill soils were underlain by relatively dense, poorly graded sand with silt and gravel alluvial deposits to the depths explored. Based on our past experience, alluvial deposits can contain cobbles. More detailed descriptions of the subsurface materials are presented on the boring logs in Appendix A.

### **6.3. Groundwater**

Groundwater was not encountered in our exploratory borings at the time of drilling. Historical high groundwater near the site is approximately 200 feet below the ground surface (California Division of Mines and Geology [CDMG], 1998). It should be noted that fluctuations in groundwater level at the project site may occur due to variations in subsurface stratification, rainfall, irrigation practices, groundwater pumping, and other factors which may not have been evident at the time of our evaluation.

## **7. FAULTING AND SEISMICITY**

Based on our review of published geologic maps and review of stereoscopic aerial photographs, no active fault traces are mapped underlying the site. Therefore, the potential for surface fault rupture is considered to be low. The subject site is not located within a State of California Earthquake Fault Zone (Alquist-Priolo Special Studies Zone, Hart and Bryant, 1997). However, the site is located in a seismically active area, as is the majority of southern California, and the potential for strong ground motion in the project area is considered significant during the design life of the proposed improvements. Table 1 presents a summary of selected principal known active faults that may affect the site, the maximum moment magnitude ( $M_{max}$ ) as published by the California Geological Survey (CGS; Cao, et al., 2003), and the fault type as defined in Table 16A-U of the California Building Code (CBC, 2001). The approximate locations of major faults in the region and their geographic relationships to the site are shown on Figure 4. The approximate fault to site distance was calculated by the computer program FRISKSP (Blake, 2001b).

**Table 1 – Principal Active Faults**

<b>Fault</b>	<b>Approximate Fault to Site Distance miles (km)<sup>1</sup></b>	<b>Maximum Moment Magnitude<sup>2</sup> (M<sub>max</sub>)</b>	<b>Fault Type<sup>3</sup></b>
Sierra Madre	3.2 (5.2)	7.2	B
San Jose	3.6 (5.8)	6.4	B
Cucamonga	8.0 (12.9)	6.9	B
Chino – Central Avenue (Elsinore)	8.6 (13.9)	6.7	B
Whittier	11.0 (17.7)	6.8	A
San Andreas	21.3 (34.2)	7.8	A
San Jacinto – San Bernardino	22.7 (36.5)	6.7	A
<b>Notes:</b> km – kilometers <sup>1</sup> Blake, 2001b <sup>2</sup> Cao, et al., 2003 <sup>3</sup> CBC, 2001; Cao, et al., 2003			

### 7.1. Ground Motion

Our evaluation of ground shaking hazard included review of a probabilistic seismic hazard assessment that consisted of statewide estimates of peak horizontal ground accelerations conducted for California (Peterson, et al., 1996). In addition, for the purposes of evaluating seismically induced geotechnical hazards at the site, a site-specific probabilistic seismic hazard analysis was performed to evaluate anticipated peak ground accelerations (PGAs) using the computer program FRISKSP developed by Blake (2001b). A probabilistic analysis incorporates uncertainties in time, recurrence intervals, size, and location (along faults) of hypothetical earthquakes. This method thus accounts for likelihood (rather than certainty) of occurrence and provides levels of ground acceleration that might be more reasonably hypothesized for a finite exposure period. FRISKSP calculates the probability of experiencing various ground accelerations at a site over a period of time and the probability of exceeding expected ground accelerations within the lifetime of the proposed structure from the significant earthquakes within a specific radius of search. For the present case, a search radius of 62 miles (100 kilometers) was selected. The earthquake magnitudes used in

this program are based on the current CGS (previously California Division of Mines and Geology [CDMG]) fault model.

The published guidelines of the CGS (Sydnor, 2004) define a PGA with a 10 percent probability of exceedance in 50 years as the Design Basis Earthquake ( $PGA_{DBE}$ ) ground motion, and this value is typically used for residential and commercial structures. The PGA with a 10 percent probability of exceedance in 100 years is defined as the Upper Bound Earthquake ( $PGA_{UBE}$ ) ground motion and is used for public schools and hospitals and other essential facilities in California. The statistical return periods for the  $PGA_{DBE}$  and  $PGA_{UBE}$  are approximately 475 and 949 years, respectively.

In evaluating the seismic hazards associated with the subject site, we have considered a PGA that has a 10 percent probability of being exceeded in 50 and 100 years (i.e.,  $PGA_{DBE}$  and  $PGA_{UBE}$ , respectively) and used an attenuation relation proposed by Bozorgnia, et al. (Blake, 2001b), for Holocene soils. The  $PGA_{DBE}$  of the site was calculated as 0.50g and the  $PGA_{UBE}$  for was calculated as 0.60g when weighted to an earthquake magnitude of 7.5. The  $PGA_{DBE}$  increased to 0.62g and the  $PGA_{UBE}$  increased to 0.76g when no magnitude weighting factor was considered in probabilistic seismic hazard analysis. These estimates of ground motion do not include near-source factors that may be applicable to the design of the structure on site. The weighted  $PGA_{DBE}$  was used in our evaluation of the seismic hazards as described below from a geotechnical engineering perspective. Whether to use the  $PGA_{DBE}$ ,  $PGA_{UBE}$ , or the Uniform Building Code (UBC) seismic design parameters as presented in Section 9.2 of this report for the structural dynamic analysis should be evaluated by the project structural engineer based on the appropriate design codes and/or criteria from the governing agency.

## **7.2. Surface Fault Rupture**

The probability of damage due to surface ground rupture is relatively low due to the lack of known active faults crossing the site. Surface ground cracking related to shaking from distant events is not considered a significant hazard, although it is a possibility.

### **7.3. Liquefaction and Dynamic Settlement**

Liquefaction is the phenomenon in which loosely deposited, granular soils and some fine-grained soils located below the water table undergo rapid loss of shear strength when subjected to strong earthquake-induced ground shaking. Ground shaking of sufficient duration can result in a loss of grain-to-grain contact due to a rapid rise in pore water pressure causing the soil to behave as a fluid for a short period. Liquefaction is known generally to occur in saturated or near-saturated cohesionless soils at depths shallower than 50 feet below the ground surface. Factors known to influence liquefaction potential include composition and thickness of soil layers, grain size, relative density, groundwater level, degree of saturation, and both intensity and duration of ground shaking.

Based on our subsurface exploration and laboratory testing, the site is underlain by relatively dense, sandy alluvial soils. Groundwater is anticipated to be approximately 200 or more feet deep. Accordingly, it is our opinion that the potential for liquefaction is negligible and the site is not susceptible to liquefaction-related seismic hazards (e.g., dynamic settlement, lateral spreading, and/or ground subsidence) during the design seismic event.

## **8. CONCLUSIONS**

Based on the results of our geotechnical evaluation, it is our opinion that the proposed improvements to the subject site is feasible from a geotechnical standpoint, provided that the recommendations presented in this report are incorporated into the design and construction of the project. In general, the following conclusions were made:

- The site is underlain by relatively shallow fill (up to approximately 5 feet deep) overlying relatively dense alluvial soils. Details regarding the placement and compaction of the fill soils, however, are unknown. Accordingly, the fill soils are considered to be not suitable for support of the structures. In order to provide suitable support for the new structures, the fill soils should be removed and recompacted or the foundations should extend into the natural soils.
- Older concrete pavement was encountered under the existing asphalt concrete. Due to the unknowns regarding the original subgrade preparation, the existing pavement materials in the area of improvements should be removed and hauled from the site.

- Due to the granular, dry nature of the on-site soils, caving of excavation sidewalls should be anticipated. Accordingly, shoring should be considered for excavations 4 or more feet deep.
- The soils onsite are relatively granular with a very low expansion potential.
- Based on our review of aerial photographs and published geologic maps, there are no known active faults or landslides underlying the site.
- Our faulting and seismicity evaluation indicated a peak horizontal ground acceleration corresponding to a design basis earthquake event of 0.50g might be expected to occur at the site.
- Groundwater was not encountered during our evaluation to the depth explored of approximately 50½ and 51½ feet.
- Based on available information regarding the historical depth to groundwater and the consistency of the on-site materials, the potential for liquefaction at the site is considered to be negligible.
- Due to the existence of relatively dense granular soils including gravels and cobbles on-site, heavy earth-moving equipment should be anticipated to excavate foundations. Material generated from the excavations should be suitable for use as compacted fill provided that they are free of oversized material greater than 4 inches in size.

## **9. RECOMMENDATIONS**

The following sections include our geotechnical recommendations for rough grading, finish grading, and construction of the structure. These recommendations are based on our evaluation of the site geotechnical conditions and a general understanding of the proposed construction. The following recommendations are also based on near surface soil conditions with low expansion potential.

### **9.1. Earthwork**

Earthwork recommendations presented in the following sections are based upon the assumption the finish grades at the site will not be changed significantly. In addition, earthwork at the site is anticipated to consist of removal of existing site improvements, removal and recompaction of existing fill soils, grading to achieve the planned finish grades, excavations for wet and dry utilities, and replacement of pavements, if appropriate.

Earthwork should be performed in accordance with the requirements of applicable governing agencies and the recommendations presented herein.

#### **9.1.1. Pre-Construction Conference**

We recommend that a pre-construction conference be held. The owner and/or their representative, the governing agencies' representatives, the civil engineer, the geotechnical engineer, and the contractor should be in attendance to discuss the work plan and project schedule.

#### **9.1.2. Site Preparation**

Prior to commencing earthwork operations, the site should be cleared of obstructions, including miscellaneous trash and debris that may be present at the time of construction. Debris from the clearing operations should be disposed off-site. After clearing, the ground surface should be stripped of pavements, surface vegetation, and associated root systems.

#### **9.1.3. Overexcavation for Improvements**

In order to provide suitable foundation support for the proposed improvements, we recommend that existing fill material that remains after the site excavations have been made be removed and recompacted. The recompaction work should consist of 1) removing existing fill material down to undisturbed natural ground, 2) scarifying, moisture conditioning, and compacting the exposed natural subgrade soils, and 3) replacing the fill material as compacted structural fill. Based on available information, we anticipate the depth of the existing fill soils is up to approximately 5 feet. The horizontal extent and depth of existing fill removals, however, should be evaluated by our representative during the excavation work based on observation of the soils exposed. In general, the limits of the overexcavation should extend approximately 5 feet outside the building limits. Any unsuitable materials (such as oversize rubble and/or organic matter) should be selectively removed and disposed of off-site.

In light of the proximity of the new structure to the existing structure, an alternative to removing and recompacting could be extending the foundations down into the relatively dense alluvial soils. This recommendation, however, does not preclude some potential settlement of the existing fill material due to poorly compacted portions of the fill or inadequately prepared subgrade.

#### **9.1.4. Fill Material**

Existing on-site soils are, in general, suitable for reuse as fill. However, rocks larger than approximately 4 inches in diameter should not be placed in the fill in the upper 3 feet of the planned finish grade elevation. Rocks up to 12 inches may be placed below a depth of 3 feet below the bottom of foundations, provided the materials are compacted in accordance with the recommendations presented in Section 9.1.5. Import fill, if used, should consist of clean, granular material with a low expansion potential (UBC expansion index of 50 or less). On-site and import fill material should be free of trash, debris, or other deleterious material. Import material, if used, should be submitted to the project geotechnical consultant for review prior to importing to the site. The contractor should be responsible for the uniformity of import material brought to the site.

#### **9.1.5. Fill Placement and Compaction**

Fill material should be placed and compacted in accordance with project specifications, the governing agencies' guidelines, and sound construction practice. Fill should be compacted with moisture content near the optimum moisture content to 90 percent or more relative compaction in accordance with the current edition of American Society for Testing and Materials (ASTM) D1557 at the time of grading.

We anticipate that oversize materials (rocks 4 or more inches) can, in general, be incorporated in the lower portions of the fill, provided the method of placement and compaction is evaluated by our representative at the time of construction. In general, the creation of voids within the fill by "nesting" of boulders and/or rock fragments should be precluded; each oversize cobble and/or rock fragment should be surrounded by a

well compacted matrix of soils. An alternative method of disposing of large cobbles is to pile or partially bury them in isolated areas for decorative purposes.

Aggregate base for the re-construction of the existing pavements should be compacted to a relative compaction of 95 percent or more as evaluated by ASTM D1557. Fill should be tested for specified compaction by our representative. The lift thickness for fill soils will vary depending on the type of compaction equipment used but should generally be placed in lifts not exceeding 8 inches in loose thickness.

#### **9.1.6. Excavation Characteristics**

Based on the results of our exploratory borings and our experience with similar soils, it is our opinion that the on-site sandy and gravel materials can be excavated using heavy earthmoving equipment. Some heavy ripping could, however, be appropriate where layers of dense cobbles are encountered. In addition, excavations for buried utilities extending into the layers of dense cobbles may be difficult to accomplish using light backhoe equipment. Contractors should, however, make their own independent evaluation of the excavatability of the on-site materials prior to submitting their bids

#### **9.1.7. Temporary Construction and Trench Excavations**

In order to perform the recommended remedial grading and/or construction, it is anticipated that cuts generally extending to a depth of approximately 5 feet or less will be made. Temporary cuts should be constructed at a 1.5:1 (horizontal to vertical) slope ratio or less. In the area adjacent to the existing building, temporary excavations should not be within 2 feet of the building. The project geotechnical engineer should evaluate these areas during grading operations and provide mitigation recommendations as needed.

Trenching for utilities that are relatively shallow (less than 4 feet) should not require special trenching or shoring considerations, provided they are performed in accordance with Occupational Safety and Health Administration's (OSHA's) requirements. It should be noted, however, that some of the on-site soils are comprised of relatively clean sands



with little cohesion. Trench and/or foundation excavations in these materials may be subject to caving. Trenches 4 feet or deeper should have shoring designed by a licensed engineer experienced in shoring design. The trenches should be sloped back in accordance with California-OSHA (Cal-OSHA) regulations for Type C soils.

Trenches should be located so as not to impair the bearing capacity or cause settlement under foundations. As a guideline, trenches adjacent to and subparallel to foundations should be clear of an imaginary 1:1 (horizontal to vertical) plane extending outward and downward from the outer edge of the foundations.

#### **9.1.8. Trench Backfill**

The soils encountered at the site should generally be suitable for reuse as backfill, provided they are free of organic material, clay lumps, debris, and rocks 4 or more inches in diameter. In light of potentially oversize materials onsite, screening of the onsite soils or selective backfill will be appropriate for the backfill soils. Fill should be moisture conditioned to near the optimum moisture content. We recommend that bedding material be placed around the pipe and 1 foot or more above the top of the pipe. The bedding material should be classified as sand, be free of organic material, and have a sand equivalent of 30 or more.

Backfill should be compacted to a relative compaction of 90 percent or more of the maximum dry density as evaluated by ASTM D 1557. Lift thickness for backfill will depend on the type of compaction equipment utilized, but fill should generally be placed in lifts not exceeding 8 inches in loose thickness. Special care should be exercised to avoid damaging the pipe during the compaction of the backfill.

## **9.2. Seismic Design Considerations**

Design of the proposed improvements should comply with design for structures located in Seismic Zone 4 and should be designed in accordance with applicable jurisdictions, building codes, and the standard practices of the Structural Engineers Association of California. A

soil profile factor of  $S_C$  may be utilized in the UBC seismic design. Additional UBC seismic design parameters are provided in Table 2.

**Table 2 – 1997 Uniform Building Code Seismic Recommendations**

1997 UBC Seismic Design Factor	Value
Seismic Zone Factor, $Z$	0.4
Seismic Source Type*	B
Near Source Factor, $N_a$	1.3
Near Source Factor, $N_v$	1.6
Soil Profile Type	$S_c$
Seismic Coefficient, $C_a$	0.52
Seismic Coefficient, $C_v$	0.90
* Faults are designated as Type A, B, or C, depending on maximum moment magnitude and slip rates (Table 16-U of UBC, 1997).	

### 9.3. Foundations

The proposed improvements may be supported on conventional shallow foundations provided the recommendations presented in this report have been followed. The foundation and slab-on-grade recommendations presented are for low expansion potential soil conditions.

#### 9.3.1. Mat Foundation

The proposed mat foundation for the storage tank may be designed using a net allowable bearing capacity of 5,000 pounds per square foot (psf) founded in competent alluvium or compacted fill. This allowable bearing pressure may be increased by one-third when considering loads of short duration such as wind or seismic forces. The total and differential settlements corresponding to this allowable bearing load are estimated to be less than approximately 1 inch and ½ inch over a horizontal span of 40 feet, respectively.

Mat foundations typically experience some deflection due to loads placed on the mat and the reaction of the soils directly underlying the mat. Mat foundations supported on competent alluvium or compacted fills may be designed using a coefficient of subgrade

reaction,  $K_{v1}$ , of 150 tons per cubic foot (pcf). This value is based on a unit area of 1 square foot and should be adjusted for large mats. Adjusted value of the coefficient of subgrade reaction for a mat of a specific width,  $K_b$ , may be evaluated using the following equation:

$$K_b = K_{v1} [(b+1)/(2b)]^2 \text{ (pcf)}$$

where  $b$  is the least width of the foundation measured in feet.

### **9.3.2. Shallow Footings**

Spread footings may be used to support the proposed structure. Footings should extend 24 inches or more below the lowest adjacent finished grade and have a width of 5 feet or greater. Footings, as described and bearing on compacted fill or competent alluvium, may be designed using an allowable bearing capacity of 3,000 psf. An additional allowable bearing pressure of 300 and 700 psf for each foot of width and depth increase, respectively, may be used to increase the allowable bearing pressure up to a maximum value of 5,000 psf. The allowable bearing pressure may be increased by up to one-third when considering loads of short duration, such as wind or seismic forces. Total and differential settlements for footings designed to sustain the recommended bearing pressures are estimated to be less than approximately 1 inch and ½ inch over a horizontal span of 40 feet, respectively.

Footings bearing on compacted fill or competent alluvium may be designed using a coefficient of friction of 0.35, where the total frictional resistance equals the coefficient of friction times the dead load. Foundations may be designed using a passive resistance value of 350 psf per foot of depth for a level ground condition. The allowable lateral resistance can be taken as the sum of the frictional resistance and passive resistance, provided the passive resistance does not exceed one-half of the total allowable resistance. The passive resistance (including the maximum value) may be increased by one-third when considering loads of short duration, such as wind or seismic forces.

Foundations should be reinforced in accordance with the recommendations of the project structural engineer. We recommend that, as a minimum, foundations be reinforced with two No. 4 reinforcing steel bars, one placed near the top of the footing and one placed near the bottom. Reinforcing bars should be covered by 3 or more inches of concrete.

#### **9.4. Concrete Placement**

In order to help reduce the potential for shrinkage cracks in the concrete during curing, we recommend that the concrete for slabs be placed with a slump of 4 inches. The slump should be checked at the site by a representative of a qualified materials testing laboratory prior to placement. Structural concrete should be placed in accordance with American Concrete Institute (ACI) and project specifications.

#### **9.5. Concrete Type**

Concrete in contact with soil or water that contains high concentrations of soluble sulfates can be subject to chemical deterioration. Based on the ACI criteria (ACI, 318-89), the potential for sulfate attack is negligible to moderate for water-soluble sulfate contents from 0 to 0.1 percent by weight. A representative soil samples were tested in this evaluation and indicated a water-soluble sulfate content of 0.015 percent and 0.010 percent for borings B-1 and B-2, respectively. Type II cement is considered appropriate in accordance with the UBC Table 19-A-3. However, due to the variability in soluble sulfate contents that may occur at a site and changes over time due to the use of fertilizers and reclaimed water, consideration should be given to using Type V cement with a water to cement ratio of 0.45 or less for the project.

#### **9.6. Corrosivity**

The corrosion potential of the site soils was evaluated using the results of representative samples obtained from the exploratory excavations. Laboratory testing was performed to

evaluate pH, minimum electrical resistivity, and chloride content and is presented in Appendix B.

The results of our resistivity testing indicated the on-site materials have an electrical resistivity of 6,700 and 3,285 ohm-centimeters for borings B-1 and B-2, respectively. This is considered to be non-corrosive to ferrous metals. The soil pH was measured to be 9.0 and 8.0 for borings B-1 and B-2, respectively, which is considered to be slightly acidic. The soil chloride content was 70 parts per million (ppm) and 140 ppm for borings B-1 and B-2, respectively, which is considered to be slightly corrosive. Based on these test results, the on-site soils may be considered mildly corrosive to ferrous metals. We recommend that a corrosion engineer utilizing these values design corrosion protection for the proposed improvements.

**9.7. Pavement Design**

Our scope of work did not include an evaluation of the existing pavements. In the event the existing pavements are excavated or damaged, that portion of the excavation within the existing pavements should conform to the material and compaction of the adjacent pavement section. For new pavements, if constructed, the subgrade soils should be evaluated based on R-value testing. For preliminary purposes, we have assumed a traffic index (TI) of 5.0 for possible new pavement areas. Preliminary pavement design sections were evaluated in accordance with the guidelines of the California Highway Design Manual (Caltrans, 1995). Based upon the TI value presented above and an assumed R-value of 40, the following pavement sections are recommended for use in preliminary planning:

**Table 3 – Preliminary Structural Pavement Sections**

Location	Traffic Index	AC over AB (inches)	Full-Depth AC (inches)	PCC over Subgrade (inches)
Pavement	5.0	3 AC/4 AB	5	6.0
<b>Notes:</b> AC – Asphalt Concrete AB – Aggregate Base PCC – Portland Cement Concrete				

Portland cement concrete pavements, cross gutters, and trash enclosure approaches should have a thickness of 6 inches or more and should be reinforced with No. 4 steel reinforcing bars, spaced 24 inches on center in both directions. The final asphalt concrete pavement sections should be based on R-value testing of the subgrade soils upon completion of finish grading operations.

Subgrade soils in areas to be paved should be compacted to 90 percent or more of the maximum dry density as evaluated by ASTM D 1557. Aggregate base and subbase material should conform to the specifications in Section 200-2 of the "Greenbook," Standard Specifications for Public Works Construction (2006) and should be compacted to 95 percent or more of the maximum dry density. Asphalt concrete should be compacted to 95 percent or more and should conform to Section 203-6 of the "Greenbook."

#### **9.8. Surface Drainage**

Surface drainage should be appropriately designed. Positive drainage should be provided and maintained to divert surface water away from foundations. Positive drainage should be established and maintained adjacent to flatwork. Positive drainage is defined as a slope of 2 percent or more for a distance of 5 feet or more away from foundations, flatwork, and tops of slopes. Runoff should then be diverted by the use of swales or pipes into a collective drainage system. Surface water should not be allowed to pond. We further recommend that the proposed structure be equipped with appropriate roof drainage systems, including downspouts. Downspouts should discharge to a system of closed pipes that transport the collected water to a suitable discharge facility. We recommend that drought tolerant vegetation be used for site landscaping. Irrigation should be kept at levels just sufficient to maintain plant vigor.

#### **9.9. Construction Observation**

The recommendations provided in this report are based on our understanding of the proposed project and on our evaluation of the data collected based on subsurface conditions disclosed by widely spaced exploratory borings. It is imperative that our representative

checks the interpolated subsurface conditions during construction. We recommend that observation and testing of compacted fill and backfill be performed during construction by our representative. We further recommend that we review the project plans and specifications prior to construction. It should be noted that, upon review of these documents, some recommendations presented in this report may be revised or modified.

The recommendations provided in this report assume that Ninyo & Moore will be retained as the geotechnical consultant during the construction phase of this project. If another geotechnical consultant is selected, we request that the selected consultant indicate to our firm in writing that our recommendations are understood and that they are in full agreement with our recommendations.

## **10. LIMITATIONS**

The field evaluation, laboratory testing, and geotechnical analyses presented in this geotechnical report have been conducted in general accordance with current practice and the standard of care exercised by geotechnical consultants performing similar tasks in the project area. No warranty, expressed or implied, is made regarding the conclusions, recommendations, and opinions presented in this report. There is no evaluation detailed enough to reveal every subsurface condition. Variations may exist and conditions not observed or described in this report may be encountered during construction. Uncertainties relative to subsurface conditions can be reduced through additional subsurface exploration. Additional subsurface evaluation will be performed upon request. Please also note that our evaluation was limited to assessment of the geotechnical aspects of the project, and did not include evaluation of structural issues, environmental concerns or the presence of hazardous materials.

This document is intended to be used only in its entirety. No portion of the document, by itself, is designed to completely represent any aspect of the project described herein. Ninyo & Moore should be contacted if the reader requires additional information or has questions regarding the content, interpretations presented, or completeness of this document.

Our conclusions, recommendations, and opinions are based on an analysis of the observed site conditions. If geotechnical conditions different from those described in this report are encountered, our office should be notified, and additional recommendations, if warranted, will be provided upon request. In the event of any changes in the nature, design, or locations of the proposed improvements, the conclusions and recommendations presented herein may not be valid unless the changes are evaluated by Ninyo & Moore and the conclusions of this report are modified in writing. It should be understood that the conditions of a site can change with time as a result of natural processes or the activities of man at the subject site or nearby sites. In addition, changes to the applicable laws, regulations, codes, and standards of practice may occur due to government action or the broadening of knowledge. The findings of this report may, therefore, be invalidated over time, in part or in whole, by changes over which Ninyo & Moore has no control.

This report is intended exclusively for use by the client. Any use or reuse of the findings, conclusions, and/or recommendations of this report by parties other than the client is undertaken at said parties' sole risk.



## 11. SELECTED REFERENCES

- Blake, T.F., 2001a, UBCSEIS (Version 1.02), Computation of 1997 Uniform Building Code Seismic Design Parameters.
- Blake, T.F., 2001b, FRISKSP (Version 4.00), A Computer Program for the Probabilistic Estimation of Peak Acceleration and Uniform Hazard Spectra Using 3-D Faults as Earthquake Sources.
- California Building Code, 2001 Edition, based upon Uniform Building Code, 1997 Edition, dated May 1.
- California Department of Conservation, Division of Mines and Geology, State of California, 1998a, Maps of Known Active Fault Near-Source Zones in California and Adjacent Portions of Nevada: International Conference of Building Officials, dated February.
- California Department of Conservation, Division of Mines and Geology, State of California, 1998b, Seismic Hazard Evaluation of the San Dimas 7.5-Minute Quadrangle, Los Angeles County, California: Open-File Report 98-23.
- California Department of Conservation, Division of Mines and Geology, State of California, 1999, Seismic Hazard Zones Official Map, San Dimas Quadrangle, 7.5-Minute Series: Scale 1:24,000, Open-File Report 98-23, dated March 25.
- California Department of Transportation, 1991, NEWCON90, dated April 30.
- California Department of Transportation, 1995, Highway Design Manual, Fourth Edition.
- California Department of Transportation, 2003, Corrosion Guidelines, Version 1.0, dated September, Engineering Science, 1984, Miramar Water Treatment Plant, Site Grading and Piping Plan – West, Sheet C-0.2, dated October 30.
- Cao, Tianqing, Bryant, William A., Rowshandel, Badie, Branum, David, and Wills, Christopher J., 2003, The Revised 2002 California Probabilistic Seismic Hazard Maps, dated June.
- Dibblee, T.W., Jr., 2002, Geologic Map of the San Dimas and Ontario Quadrangles, Los Angeles and San Bernardino Counties, California: Dibblee Foundation, DF-91, Scale 1:24,000.
- Google Earth Pro, 2007, 225 West Arrow Highway, Glendora, California.
- Hart, E.W., and Bryant, W.A., 1997, Fault-Rupture Hazard Zones in California, Alquist-Priolo Earthquake Fault Zoning Act with Index to Earthquake Fault Zone Maps: California Department of Conservation, Division of Mines and Geology, Special Publication 42, with Supplements 1 and 2 added in 1999.
- International Conference of Building Officials, 1997, Uniform Building Code, dated May 1.

Jennings, C.W., 1994, Fault Activity Map of California and Adjacent Areas: California Division of Mines and Geology, California Geologic Data Map Series, Map No. 6, Scale 1:750,000.

Joint Cooperative Committee of the Southern California Chapter of the American Public Works Association and Southern California Districts of the Associated General Contractors of California, 2006, "Greenbook," Standard Specifications for Public Works Construction: BNI Building News, Los Angeles, California.

Morton, D.M., and Miller, F.K., 2003, Preliminary Geologic Map of The San Bernardino 30' x 60' Quadrangle, California, Version 1.0: United States Geological Survey Open-File Report 03-293, Scale 1:100,000.

Ninyo & Moore, Unpublished and Proprietary In-house Data.

Ninyo & Moore, 2007, Proposal for Geotechnical Consulting Services, Covina Irrigation Company, 225 West Arrow Highway, Glendora, California, dated October 8.

Peterson, M.D., Bryant, W.A., Cramer, C.H., Cao, T., Reichle, M.S., Frankel, A.D., Lienkaemper, J.J., McCrory, P.A., and Schwartz, D.P., 1996, Probabilistic Seismic Hazard Assessment for the State of California: California Department of Conservation, Division of Mines and Geology Open File Report 96-08.

Seed, H.B., and Idriss, I.M., 1982, Ground Motions and Soil Liquefaction During Earthquakes, Volume 5 of Engineering Monographs on Earthquake Criteria, Structural Design, and Strong Motion Records: Berkeley, Earthquake Engineering Research Institute.

Sydnor, R.H., 2004, Checklist for the Review of Engineering Geology and Seismology Reports for California Public Schools, Hospitals, and Essential Services Buildings: California Geological Survey, Note 48, dated January 1.

United States Geological Survey, 1967 (Photorevised 1981), San Dimas, California Quadrangle Map, 7.5 Minute Series: Scale 1:24,000.

<b>AERIAL PHOTOGRAPHS</b>				
<b>Source</b>	<b>Date</b>	<b>Scale</b>	<b>Flight</b>	<b>Numbers</b>
USDA	1-2-53	1:20,000	AXJ-9K	80 and 82

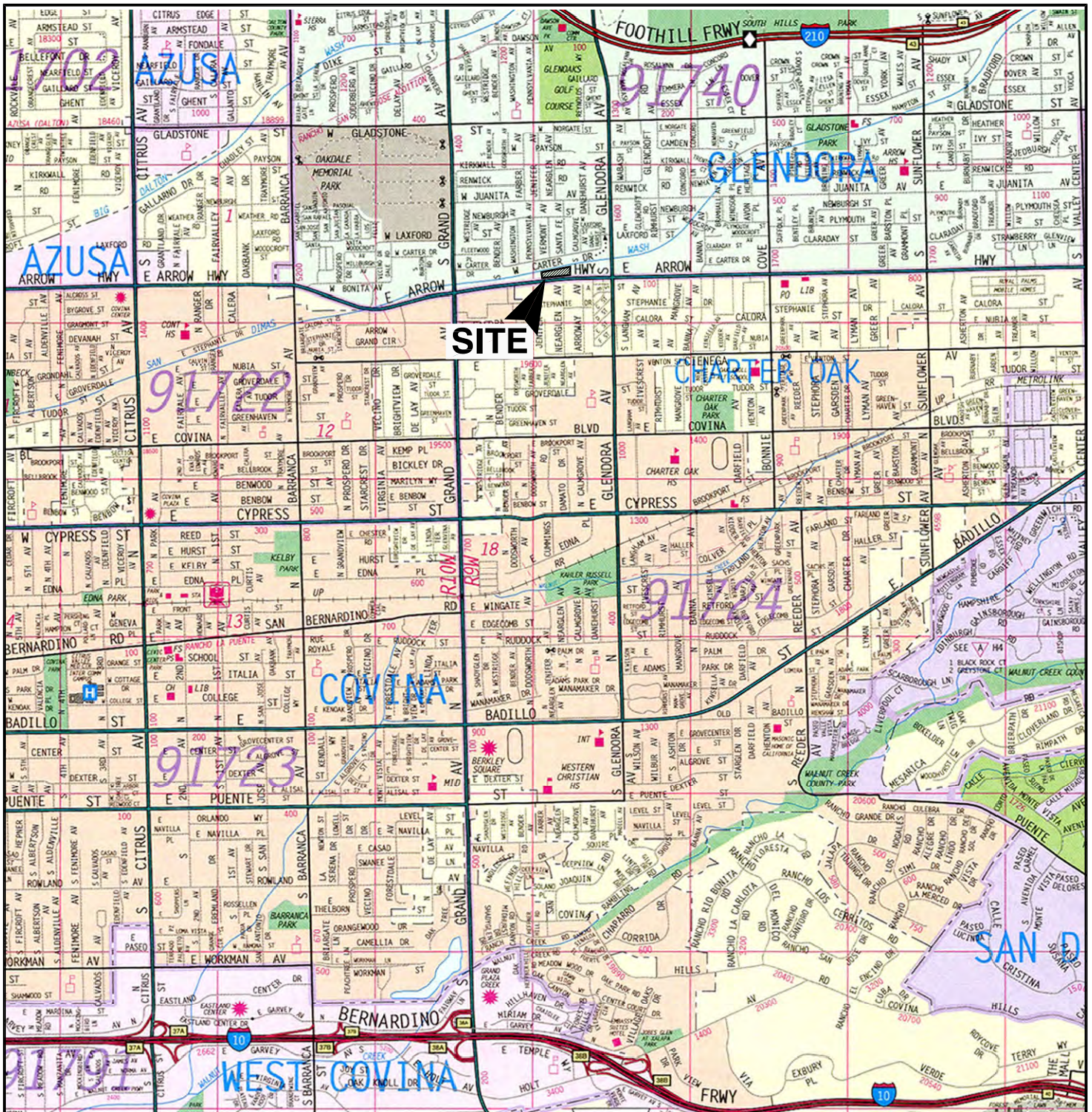

REFERENCE: 2005 THOMAS GUIDE FOR LOS ANGELES/ORANGE COUNTIES, STREET GUIDE AND DIRECTORY

APPROXIMATE SCALE IN FEET

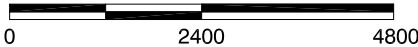

NOTE: ALL DIMENSIONS, DIRECTIONS AND LOCATIONS ARE APPROXIMATE.

**Ninyo & Moore**

**SITE LOCATION MAP**

FIGURE

PROJECT NO.	DATE
207296001	12/07

COVINA IRRIGATION COMPANY  
225 W. ARROW HIGHWAY  
GLENDDORA, CALIFORNIA

**1**

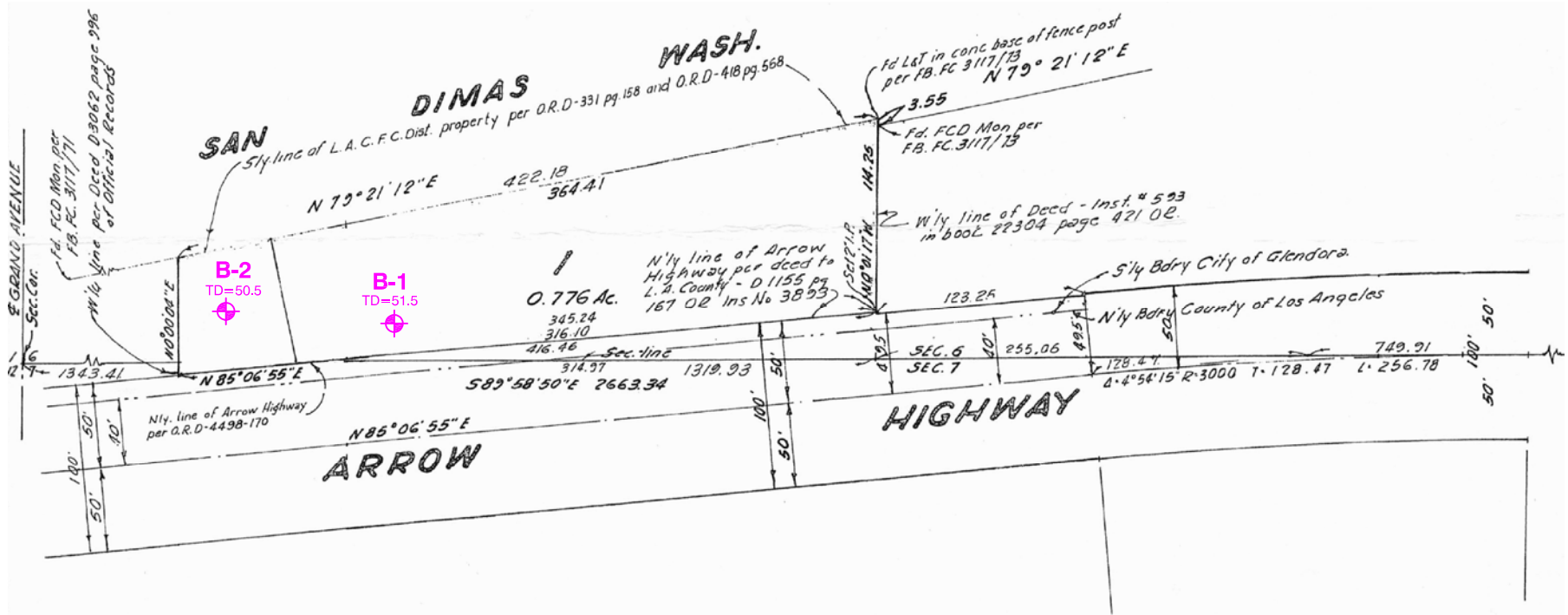

REFERENCE: PARCEL MAP NO. 1326 IN THE CITY OF GLENDORA, COUNTY OF LOS ANGELES, STATE OF CALIFORNIA BY HAROLD L. JOHNSON ENGINEERING, JULY 1969.

LEGEND	
B-2	APPROXIMATE LOCATION OF EXPLORATORY BORING
TD=50.5	TD=TOTAL DEPTH IN FEET



APPROXIMATE SCALE IN FEET

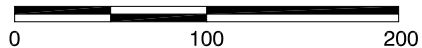

NOTE: ALL DIMENSIONS, DIRECTIONS AND LOCATIONS ARE APPROXIMATE.

		<b>BORING LOCATION MAP</b>	FIGURE  <b>2</b>
207296001		COVINA IRRIGATION COMPANY 225 W. ARROW HIGHWAY GLENDORA, CALIFORNIA	

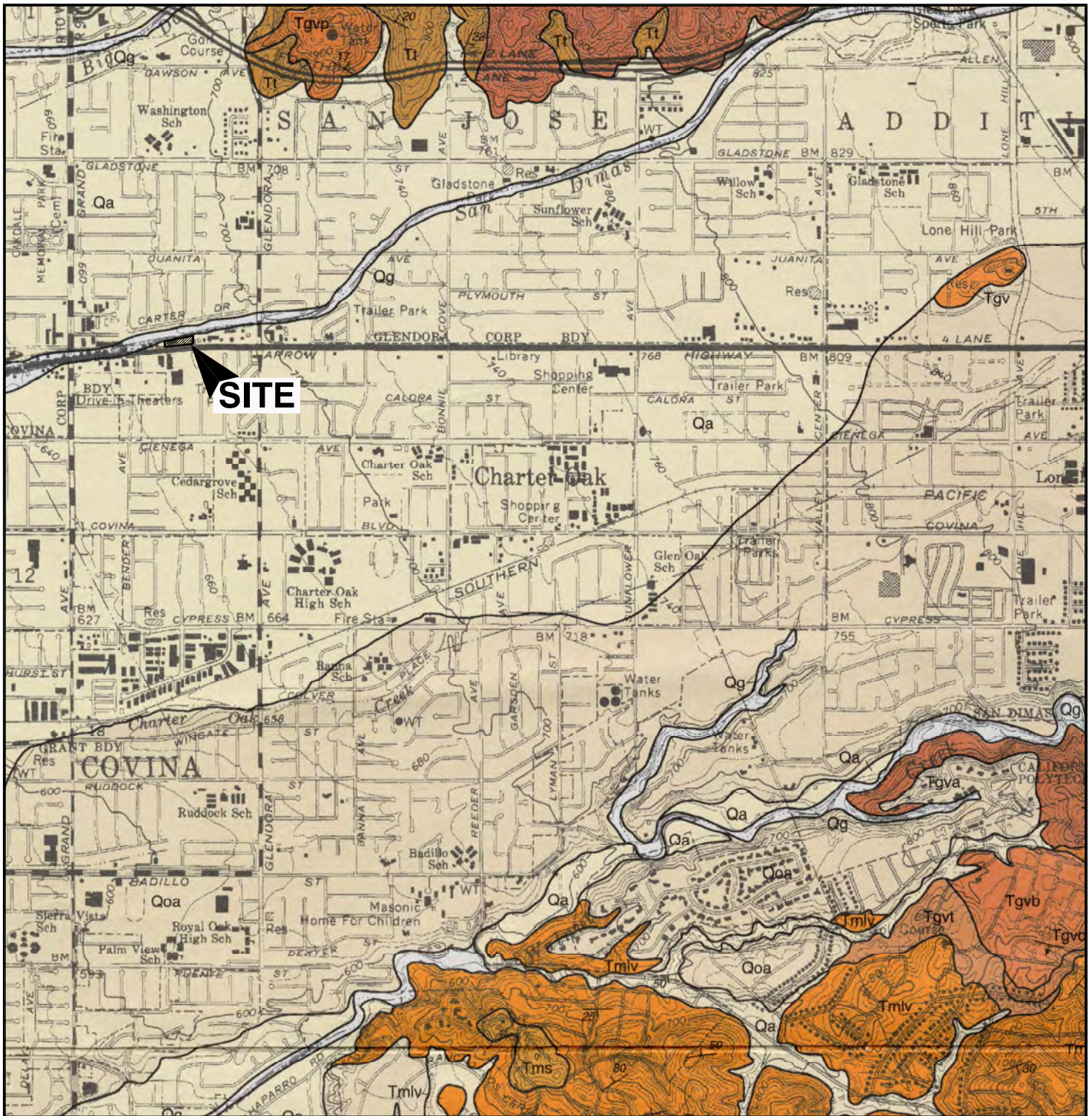

REFERENCE: GEOLOGIC MAP OF THE SAN DIMAS AND ONTARIO QUADRANGLES, LOS ANGELES AND SAN BERNARDINO COUNTIES, CALIFORNIA  
 BY THOMAS W. DIBBLE, JR., 2002.

LEGEND	
<b>SURFICIAL SEDIMENTS</b>	
af	artificial fill
Qg	alluvial gravel and sand of stream channels, some artificially channelized
Qa	alluvial gravel and sand of valley areas
<b>OLDER, DISSECTED SURFICIAL SEDIMENTS</b>	
Qoa	low remnants of elevated alluvial gravel
Qog	high remnants of elevated older alluvial gravel, including coarse boulder gravel

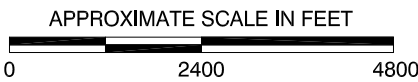

NOTE: ALL DIMENSIONS, DIRECTIONS AND LOCATIONS ARE APPROXIMATE.

**Ninyo & Moore**

**REGIONAL GEOLOGIC MAP**

FIGURE

PROJECT NO.	DATE
207296001	12/07

COVINA IRRIGATION COMPANY  
 225 W. ARROW HIGHWAY  
 GLENDORA, CALIFORNIA

**3**

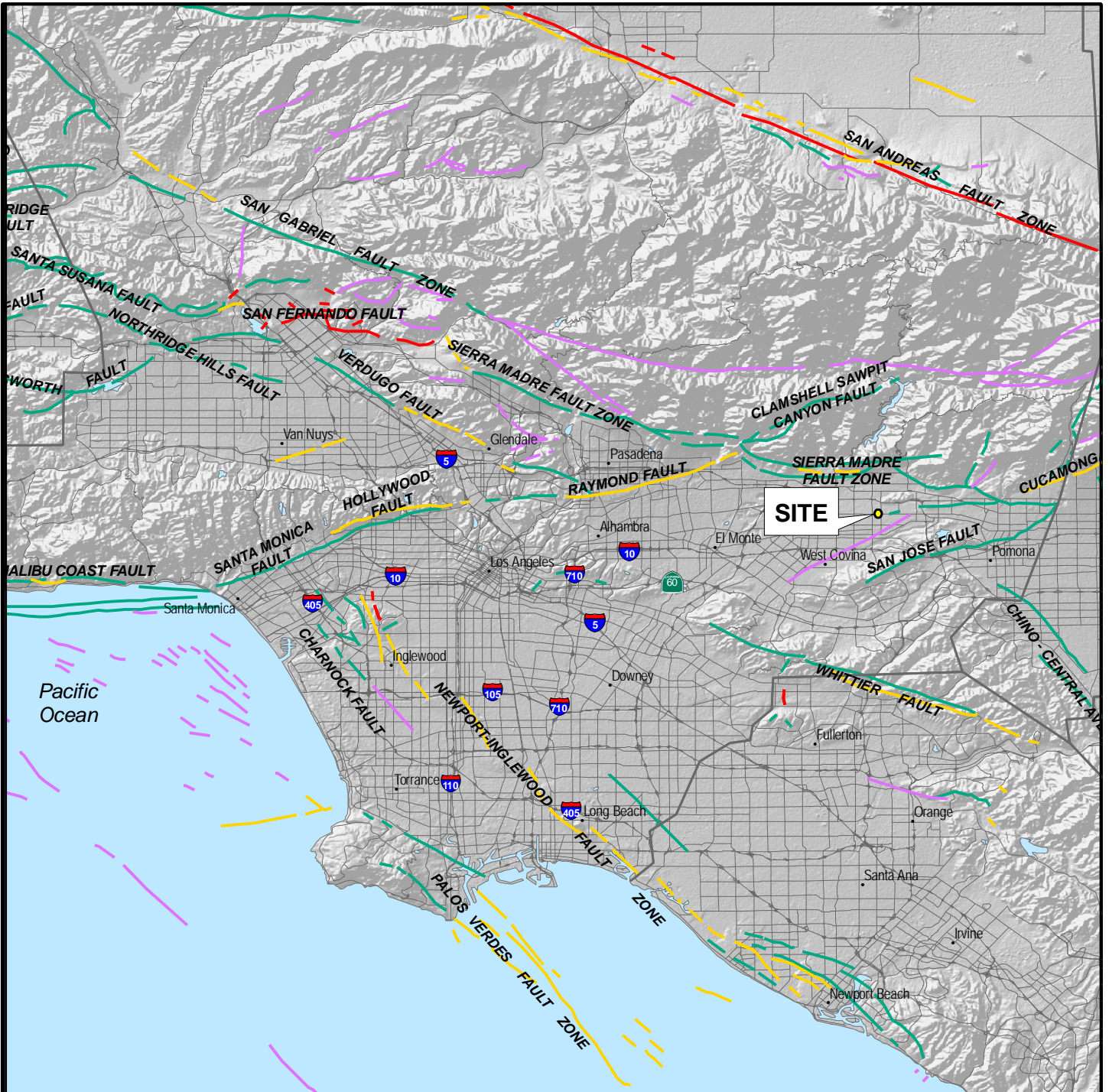

GIS DATA SOURCE: CALIFORNIA GEOLOGICAL SURVEY (CGS); ENVIRONMENTAL SYSTEMS RESEARCH INSTITUTE (ESRI)  
 REFERENCE: JENNINGS, 1994, FAULT ACTIVITY MAP OF CALIFORNIA AND ADJACENT AREAS

**LEGEND**

**FAULT ACTIVITY:**

- HISTORICALLY ACTIVE
- HOLOCENE ACTIVE
- COUNTY BOUNDARIES
- LATE QUATERNARY
- QUATERNARY

NOTE: ALL DIMENSIONS, DIRECTIONS, AND LOCATIONS ARE APPROXIMATE

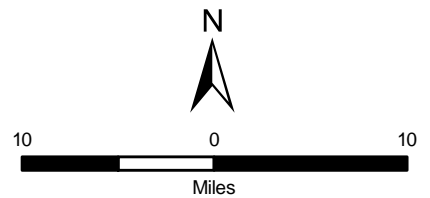

<b>Ninyo &amp; Moore</b>		<b>FAULT LOCATION MAP</b>	FIGURE
PROJECT NO.	DATE	COVINA IRRIGATION COMPANY 225 W. ARROW HIGHWAY GLENORA, CALIFORNIA	<b>4</b>
207296001	12/07		

## **APPENDIX A**

### **BORING LOGS**

#### **Field Procedure for the Collection of Disturbed Samples**

Disturbed soil samples were obtained in the field using the following methods.

##### **Bulk Samples**

Bulk samples of representative earth materials were obtained from the exploratory borings. The samples were bagged and transported to the laboratory for testing.

##### **The Standard Penetration Test (SPT) Spoon Sampler**

Disturbed drive samples of earth materials were obtained by means of an SPT spoon sampler. The sampler is composed of a split barrel with an external diameter of 2 inches and an unlined internal diameter of  $1\frac{3}{8}$  inches. The spoon was driven into the ground 12 to 18 inches with a 140-pound hammer free-falling from a height of 30 inches in general accordance with ASTM D 1586-99. The blow counts were recorded for every 6 inches of penetration; the blow counts reported on the logs are those for the last 12 inches of penetration. Soil samples were observed and removed from the spoon, bagged, sealed, and transported to the laboratory for testing.

#### **Field Procedure for the Collection of Relatively Undisturbed Samples**

Relatively undisturbed soil samples were obtained in the field using the following method.

##### **The Modified Split-Barrel Drive Sampler**

The sampler, with an external diameter of 3 inches, was lined with 1-inch-long, thin brass rings with inside diameters of approximately 2.4 inches. The sample barrel was driven into the ground with the weight of a hammer or the Kelly bar of the drill rig in general accordance with ASTM D 3550. The driving weight was permitted to fall freely. The approximate length of the fall, the weight of the hammer or bar, and the number of blows per foot of driving are presented on the boring logs as an index to the relative resistance of the materials sampled. The samples were removed from the sample barrel in the brass rings, sealed, and transported to the laboratory for testing.

## U.S.C.S. METHOD OF SOIL CLASSIFICATION

MAJOR DIVISIONS	SYMBOL	TYPICAL NAMES	
<b>COARSE-GRAINED SOILS</b> (More than 1/2 of soil >No. 200 sieve size)	<b>GRAVELS</b> (More than 1/2 of coarse fraction > No. 4 sieve size)	GW	Well graded gravels or gravel-sand mixtures, little or no fines
		GP	Poorly graded gravels or gravel-sand mixtures, little or no fines
		GM	Silty gravels, gravel-sand-silt mixtures
		GC	Clayey gravels, gravel-sand-clay mixtures
	<b>SANDS</b> (More than 1/2 of coarse fraction <No. 4 sieve size)	SW	Well graded sands or gravelly sands, little or no fines
		SP	Poorly graded sands or gravelly sands, little or no fines
		SM	Silty sands, sand-silt mixtures
<b>FINE-GRAINED SOILS</b> (More than 1/2 of soil <No. 200 sieve size)	<b>SILTS &amp; CLAYS</b> Liquid Limit <50	ML	Inorganic silts and very fine sands, rock flour, silty or clayey fine sands or clayey silts with
		CL	Inorganic clays of low to medium plasticity, gravelly clays, sandy clays, silty clays, lean
		OL	Organic silts and organic silty clays of low plasticity
	<b>SILTS &amp; CLAYS</b> Liquid Limit >50	MH	Inorganic silts, micaceous or diatomaceous fine sandy or silty soils, elastic silts
		CH	Inorganic clays of high plasticity, fat clays
		OH	Organic clays of medium to high plasticity, organic silty clays, organic silts
		Pt	Peat and other highly organic soils
<b>HIGHLY ORGANIC SOILS</b>			

GRAIN SIZE CHART		
CLASSIFICATION	RANGE OF GRAIN SIZE	
	U.S. Standard Sieve Size	Grain Size in Millimeters
<b>BOULDERS</b>	Above 12"	Above 305
<b>COBBLES</b>	12" to 3"	305 to 76.2
<b>GRAVEL</b> Coarse Fine	3" to No. 4	76.2 to 4.76
	3" to 3/4"	76.2 to 19.1
	3/4" to No. 4	19.1 to 4.76
<b>SAND</b> Coarse Medium Fine	No. 4 to No. 200	4.76 to 0.075
	No. 4 to No. 10	4.76 to 2.00
	No. 10 to No. 40	2.00 to 0.420
	No. 40 to No. 200	0.420 to 0.075
<b>SILT &amp; CLAY</b>	Below No. 200	Below 0.075

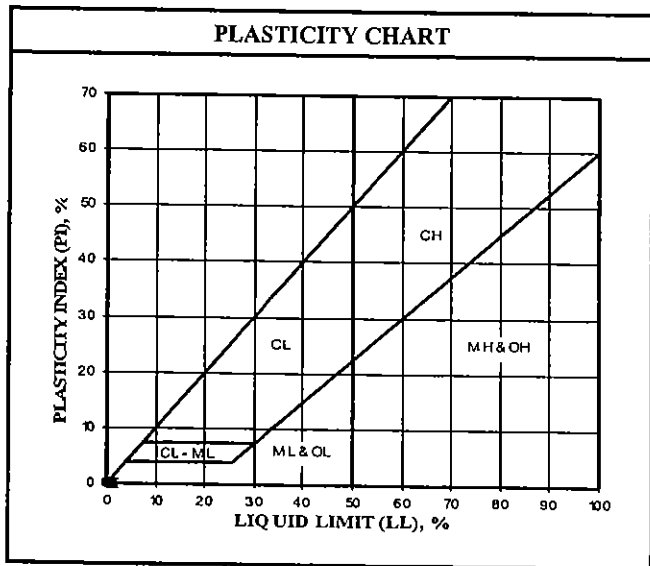

U.S.C.S. METHOD OF SOIL CLASSIFICATION



# BORING LOG EXPLANATION SHEET

DEPTH (feet)	Bulk Samples Driven	BLOWS/FOOT	MOISTURE (%)	DRY DENSITY (PCF)	SYMBOL	CLASSIFICATION U.S.C.S.	
0	█						Bulk sample.
	█						Modified split-barrel drive sampler.
	█						No recovery with modified split-barrel drive sampler.
	█						Sample retained by others.
	█						Standard Penetration Test (SPT).
5	█						No recovery with a SPT.
	█	XX/XX					Shelby tube sample. Distance pushed in inches/length of sample recovered in inches.
	█						No recovery with Shelby tube sampler.
	█						Continuous Push Sample.
	█		○				Seepage.
10	█						Groundwater encountered during drilling.
	█						Groundwater measured after drilling.
	█				█	SM	ALLUVIUM: Solid line denotes unit change.
	█				---		Dashed line denotes material change.
15	█						Attitudes: Strike/Dip b: Bedding c: Contact j: Joint f: Fracture F: Fault cs: Clay Seam s: Shear bss: Basal Slide Surface sf: Shear Fracture sz: Shear Zone sbs: Sheared Bedding Surface
20	█						The total depth line is a solid line that is drawn at the bottom of the boring.



## BORING LOG

### EXPLANATION OF BORING LOG SYMBOLS

PROJECT NO.

DATE  
Rev. 01/03

FIGURE

DEPTH (feet)	SAMPLES		BLOWS/FOOT	MOISTURE (%)	DRY DENSITY (PCF)	SYMBOL	CLASSIFICATION U.S.C.S.	DATE DRILLED <u>10/30/07</u> BORING NO. <u>B-1</u>		
	Bulk	Driven						GROUND ELEVATION <u>674' ± (MSL)</u> SHEET <u>1</u> OF <u>3</u>		
								METHOD OF DRILLING <u>8" Hollow-Stem Auger (Martini Drilling)</u>		
								DRIVE WEIGHT <u>140 lbs. (Auto. Trip Hammer)</u> DROP <u>30"</u>		
								SAMPLED BY <u>MCP</u> LOGGED BY <u>MCP</u> REVIEWED BY <u>JJB/CAP</u>		
								<b>DESCRIPTION/INTERPRETATION</b>		
0							GM	<u>ASPHALT CONCRETE:</u> Approximately 4 1/2 inches thick.		
							GM	<u>AGGREGATE BASE:</u> Brown to yellow brown, damp, medium dense, silty GRAVEL.		
			45	2.6	107.5		SM	<u>PORTLAND CEMENT CONCRETE:</u> Approximately 3 to 4 inches thick.		
								<u>AGGREGATE BASE:</u> Brown to yellow brown, damp, dense, silty GRAVEL.		
								<u>FILL:</u> Grayish brown, damp, medium dense, silty SAND with gravel.		
5			23				SP-SM	<u>ALLUVIUM:</u> Brown to yellow brown, moist, dense, poorly graded SAND with silt; few fine gravel; trace coarse gravel.		
10			57	5.3	119.3					
15			26							
20										

**Ninyo & Moore**

**BORING LOG**

Covina Irrigation Company  
 255 W. Arrow Highway, Glendora, California

PROJECT NO.  
 207296001

DATE  
 12/07

FIGURE  
 A-1

DEPTH (feet)	SAMPLES		BLOWS/FOOT	MOISTURE (%)	DRY DENSITY (PCF)	SYMBOL	CLASSIFICATION U.S.C.S.	DATE DRILLED <u>10/30/07</u> BORING NO. <u>B-1</u>		
	Bulk	Driven						GROUND ELEVATION <u>674' ± (MSL)</u>	SHEET <u>2</u> OF <u>3</u>	METHOD OF DRILLING <u>8" Hollow-Stem Auger (Martini Drilling)</u>
								DRIVE WEIGHT <u>140 lbs. (Auto. Trip Hammer)</u>	DROP <u>30"</u>	SAMPLED BY <u>MCP</u> LOGGED BY <u>MCP</u> REVIEWED BY <u>JJB/CAP</u>
								<b>DESCRIPTION/INTERPRETATION</b>		
20			84	3.2	124.1		SP-SM	<b>ALLUVIUM: (Continued)</b> Brown to yellow brown, moist, very dense, poorly graded SAND with silt; scattered lenses of poorly graded gravel.		
25			77							
30			95/9"	4.5	119.4					
35			72/11"							
40										



**BORING LOG**

Covina Irrigation Company  
 255 W. Arrow Highway, Glendora, California

PROJECT NO.  
 207296001

DATE  
 12/07

FIGURE  
 A-2

DEPTH (feet)	SAMPLES		BLOWS/FOOT	MOISTURE (%)	DRY DENSITY (PCF)	SYMBOL	CLASSIFICATION U.S.C.S.	DATE DRILLED <u>10/30/07</u> BORING NO. <u>B-1</u>	
	Bulk	Driven						GROUND ELEVATION <u>674' ± (MSL)</u>	SHEET <u>3</u> OF <u>3</u>
								METHOD OF DRILLING <u>8" Hollow-Stem Auger (Martini Drilling)</u>	
								DRIVE WEIGHT <u>140 lbs. (Auto. Trip Hammer)</u> DROP <u>30"</u>	
								SAMPLED BY <u>MCP</u> LOGGED BY <u>MCP</u> REVIEWED BY <u>JJB/CAP</u>	
								<b>DESCRIPTION/INTERPRETATION</b>	
40			83/10"	6.0			SP-SM	<u>ALLUVIUM:</u> (Continued) Brown to yellow brown, moist, very dense, poorly graded SAND with silt and gravel.	
45			95/11"					Trace clay.	
50			83	4.3					
55								Total Depth = 51.5 feet. No groundwater encountered during drilling. Backfilled with on-site soils and capped with quick-set concrete on 10/30/07.	
60								<u>Note:</u> Groundwater, though not encountered at the time of drilling, may rise to a higher level due to seasonal variations in precipitation and several other factors as discussed in the report.	



**BORING LOG**

Covina Irrigation Company  
 255 W. Arrow Highway, Glendora, California

PROJECT NO.  
 207296001

DATE  
 12/07

FIGURE  
 A-3

DEPTH (feet)	SAMPLES		BLOWS/FOOT	MOISTURE (%)	DRY DENSITY (PCF)	SYMBOL	CLASSIFICATION U.S.C.S.	DATE DRILLED <u>10/30/07</u> BORING NO. <u>B-2</u>	
	Bulk	Driven						GROUND ELEVATION <u>673' ± (MSL)</u>	SHEET <u>1</u> OF <u>3</u>
								METHOD OF DRILLING <u>8" Hollow-Stem Auger (Martini Drilling)</u>	
								DRIVE WEIGHT <u>140 lbs. (Auto. Trip Hammer)</u> DROP <u>30"</u>	
								SAMPLED BY <u>MCP</u> LOGGED BY <u>MCP</u> REVIEWED BY <u>JJB/CAP</u>	
								<b>DESCRIPTION/INTERPRETATION</b>	
0							SP	<b>ASPHALT CONCRETE:</b> Approximately 4 1/2 inches thick. <b>FILL:</b> Grayish brown, damp, medium dense, poorly graded SAND.	
			54	2.4	126.5				
							SP-SM	<b>ALLUVIUM:</b> Brown to yellow brown, damp, very dense, poorly graded SAND with silt; some fine to coarse gravel.	
5			64	3.8	128.8				
10			18					Medium dense.	
15			85	4.7	122.0			Very dense.	
20									



**BORING LOG**

Covina Irrigation Company  
 255 W. Arrow Highway, Glendora, California

PROJECT NO. 207296001	DATE 12/07	FIGURE A-4
--------------------------	---------------	---------------

DEPTH (feet)	SAMPLES Bulk Driven	BLOWS/FOOT	MOISTURE (%)	DRY DENSITY (PCF)	SYMBOL	CLASSIFICATION U.S.C.S.	DATE DRILLED	BORING NO.	
							10/30/07	B-2	
							GROUND ELEVATION	SHEET	OF
							673' ± (MSL)	2	3
							METHOD OF DRILLING 8" Hollow-Stem Auger (Martini Drilling)		
							DRIVE WEIGHT	DROP	
							140 lbs. (Auto. Trip Hammer)	30"	
							SAMPLED BY	LOGGED BY	REVIEWED BY
							MCP	MCP	JJB/CAP
							<b>DESCRIPTION/INTERPRETATION</b>		
20		41				SP-SM	<u>ALLUVIUM:</u> (Continued) Brown to yellow brown, damp, very dense, poorly graded SAND with silt; some fine to coarse gravel; granitic clasts up to approximately 3 inches in diameter.		
25		78	2.6	117.5			Scattered lenses of poorly graded sand.		
30		60	3.0				Clasts up to approximately 5 inches.		
35		50							
40									



**BORING LOG**

Covina Irrigation Company  
255 W. Arrow Highway, Glendora, California

PROJECT NO.	DATE	FIGURE
207296001	12/07	A-5

DEPTH (feet)	SAMPLES		BLOWS/FOOT	MOISTURE (%)	DRY DENSITY (PCF)	SYMBOL	CLASSIFICATION U.S.C.S.	DATE DRILLED	BORING NO.				
	Bulk	Driven						10/30/07	B-2				
								GROUND ELEVATION	SHEET	OF			
								673' ± (MSL)	3	3			
								METHOD OF DRILLING	8" Hollow-Stem Auger (Martini Drilling)				
								DRIVE WEIGHT	140 lbs. (Auto. Trip Hammer)	DROP	30"		
								SAMPLED BY	MCP	LOGGED BY	MCP	REVIEWED BY	JJB/CAP
								<b>DESCRIPTION/INTERPRETATION</b>					
40			72				SP-SM	<b>ALLUVIUM:</b> (Continued) Brown to yellow brown, damp, very dense, poorly graded SAND with silt; some fine to coarse gravel.					
45			86/11"										
50			50/6"										
55								Total Depth = 50.5 feet. No groundwater encountered during drilling. Backfilled with on-site soils and capped with quick-set concrete on 10/30/07.					
60								<u>Note:</u> Groundwater, though not encountered at the time of drilling, may rise to a higher level due to seasonal variations in precipitation and several other factors as discussed in the report.					



**BORING LOG**

Covina Irrigation Company  
255 W. Arrow Highway, Glendora, California

PROJECT NO.	DATE	FIGURE
207296001	12/07	A-6

## **APPENDIX B**

### **LABORATORY TESTING**

#### **Classification**

Soils were visually and texturally classified in accordance with the Unified Soil Classification System (USCS) in general accordance with ASTM D 2488. Soil classifications are indicated on the logs of the exploratory excavations in Appendix A.

#### **In-Place Moisture and Density Tests**

The moisture content and dry density of relatively undisturbed samples obtained from the exploratory excavations were evaluated in general accordance with ASTM D 2937. The test results are presented on the logs of the exploratory excavations in Appendix A.

#### **200 Wash**

An evaluation of the percentage of particles finer than the No. 200 sieve in selected soil samples was performed in general accordance with ASTM D 1140. The results of the tests are presented on Figure B-1.

#### **Gradation Analysis**

Gradation analysis tests were performed on selected representative soil samples in general accordance with ASTM D 422. The grain-size distribution curves are shown on Figures B-2 through B-5. These test results were utilized in evaluating the soil classifications in accordance with the USCS.

#### **Proctor Density Tests**

The maximum dry density and optimum moisture content of selected representative soil samples were evaluated using the Modified Proctor method in general accordance with ASTM D 1557. The results of these tests are summarized on Figure B-6.

#### **Direct Shear Tests**

A direct shear test was performed on a remolded sample in general accordance with ASTM D 3080 to evaluate the shear strength characteristics of selected materials. The sample was inundated during shearing to represent adverse field conditions. The results are shown on Figure B-7.

#### **Soil Corrosivity Tests**

Soil pH and resistivity tests were performed on representative samples in general accordance with California Test (CT) 643. The soluble sulfate and chloride content of selected samples were



evaluated in general accordance with CT 417 and CT 422, respectively. The test results are presented on Figure B-8.

SAMPLE LOCATION	SAMPLE DEPTH (FT)	DESCRIPTION	PERCENT PASSING NO. 4	PERCENT PASSING NO. 200	USCS (TOTAL SAMPLE)
B-1	20.0-21.5	Poorly Graded SAND with Gravel	52	4	SP-SM
B-1	40.0-41.5	Poorly Graded SAND with Silt and Gravel	65	8	SP-SM

PERFORMED IN GENERAL ACCORDANCE WITH ASTM D 1140-00

<b><i>Ninyo &amp; Moore</i></b>		<b>NO. 200 SIEVE ANALYSIS</b>	FIGURE
PROJECT NO.	DATE	Covina Irrigation Company 225 West Arrow Highway Glendora, California	<b>B-1</b>
207296001	12/07		

GRAVEL		SAND			FINES	
Coarse	Fine	Coarse	Medium	Fine	SILT	CLAY

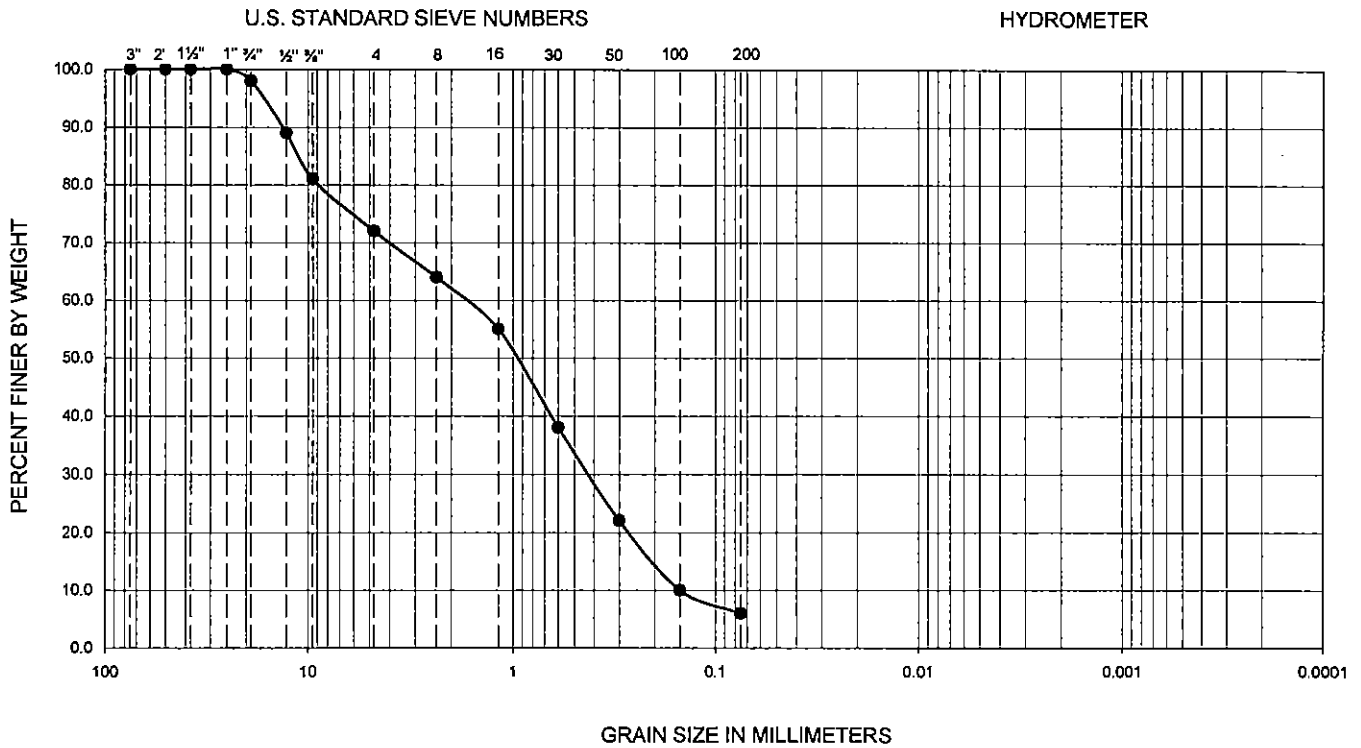

Symbol	Sample Location	Depth (ft)	Liquid Limit	Plastic Limit	Plasticity Index	D <sub>10</sub>	D <sub>30</sub>	D <sub>60</sub>	C <sub>u</sub>	C <sub>c</sub>	Passing No. 200 (%)	USCS
●	B-1	10.0-11.5	--	--	--	0.15	0.41	1.65	11.0	0.7	6	SP-SM

PERFORMED IN GENERAL ACCORDANCE WITH ASTM D 422-63 (02)

<b>Ninyo &amp; Moore</b>		<b>GRADATION TEST RESULTS</b>		FIGURE <b>B-2</b>
PROJECT NO.	DATE	Covina Irrigation Company 225 West Arrow Highway Glendora, California		
207296001	12/07			

GRAVEL		SAND			FINES	
Coarse	Fine	Coarse	Medium	Fine	SILT	CLAY

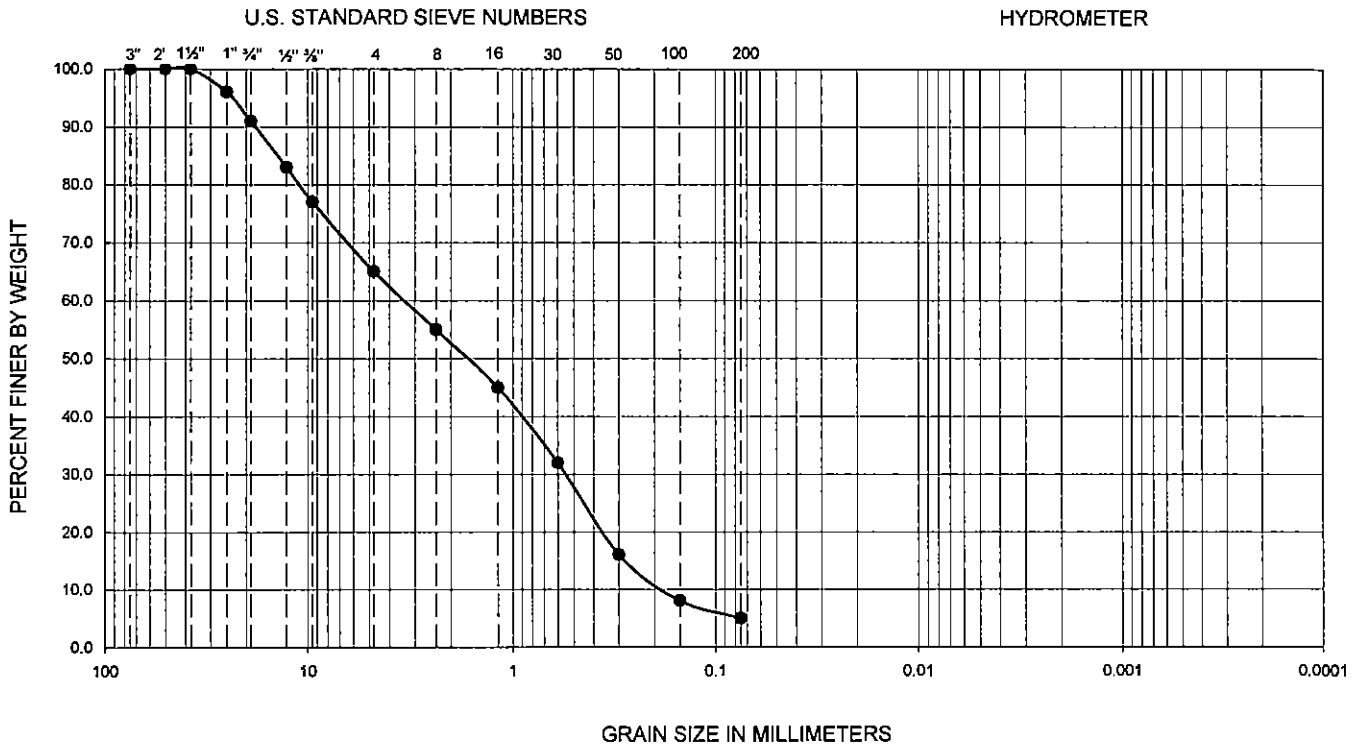

Symbol	Sample Location	Depth (ft)	Liquid Limit	Plastic Limit	Plasticity Index	D <sub>10</sub>	D <sub>30</sub>	D <sub>60</sub>	C <sub>u</sub>	C <sub>c</sub>	Passing No. 200 (%)	USCS
●	B-1	30.0-31.5	--	-	-	0.18	0.54	3.40	18.9	0.5	5	SP-SM

PERFORMED IN GENERAL ACCORDANCE WITH ASTM D 422-63 (02)

<b>Ninyo &amp; Moore</b>		<b>GRADATION TEST RESULTS</b>		FIGURE <b>B-3</b>
PROJECT NO.	DATE	Covina Irrigation Company 225 West Arrow Highway Glendora, California		
207296001	12/07			

GRAVEL		SAND			FINES	
Coarse	Fine	Coarse	Medium	Fine	SILT	CLAY

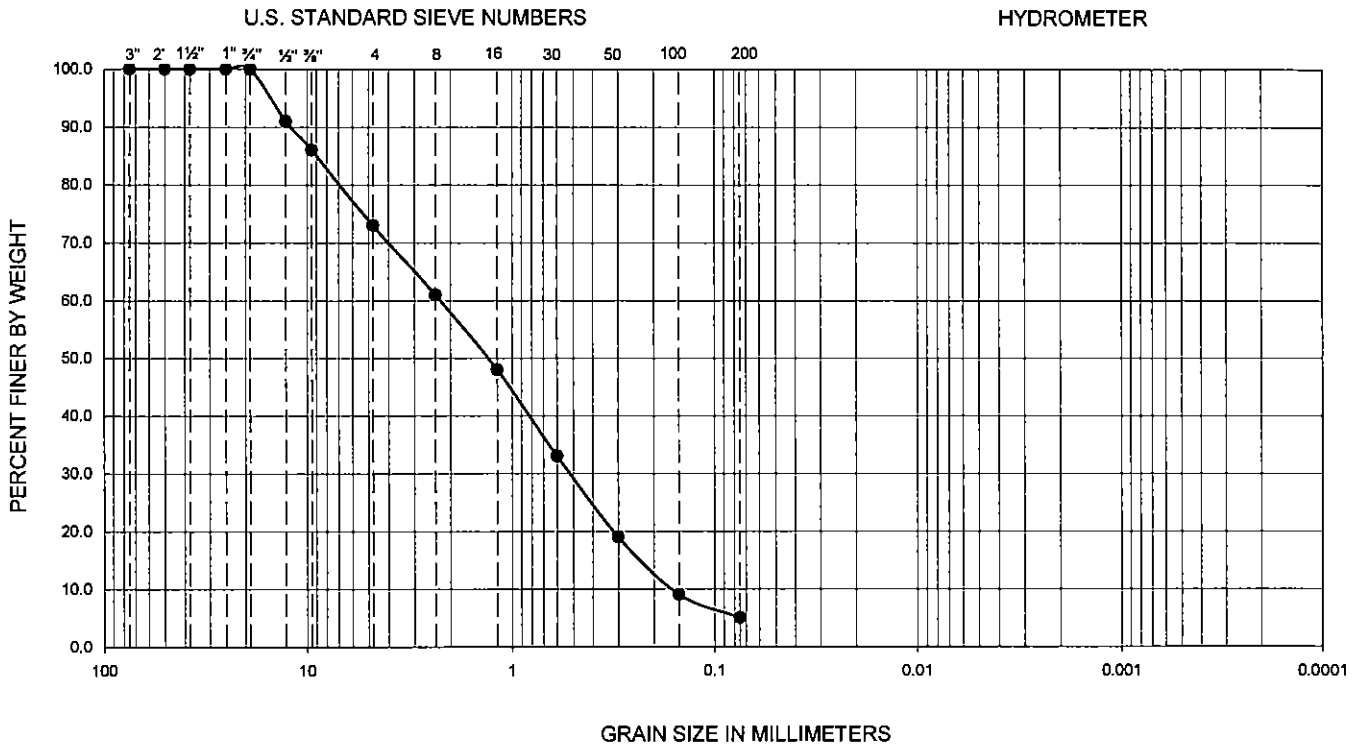

Symbol	Sample Location	Depth (ft)	Liquid Limit	Plastic Limit	Plasticity Index	D <sub>10</sub>	D <sub>30</sub>	D <sub>60</sub>	C <sub>u</sub>	C <sub>c</sub>	Passing No. 200 (%)	USCS
●	B-2	20.0-21.5	--	--	--	0.16	0.51	2.20	13.8	0.7	5	SP-SM

PERFORMED IN GENERAL ACCORDANCE WITH ASTM D 422-63 (02)

<b>Ninyo &amp; Moore</b>		<b>GRADATION TEST RESULTS</b>		FIGURE <b>B-4</b>
PROJECT NO.	DATE	Covina Irrigation Company 225 West Arrow Highway Glendora, California		
207296001	12/07			

GRAVEL		SAND			FINES	
Coarse	Fine	Coarse	Medium	Fine	SILT	CLAY

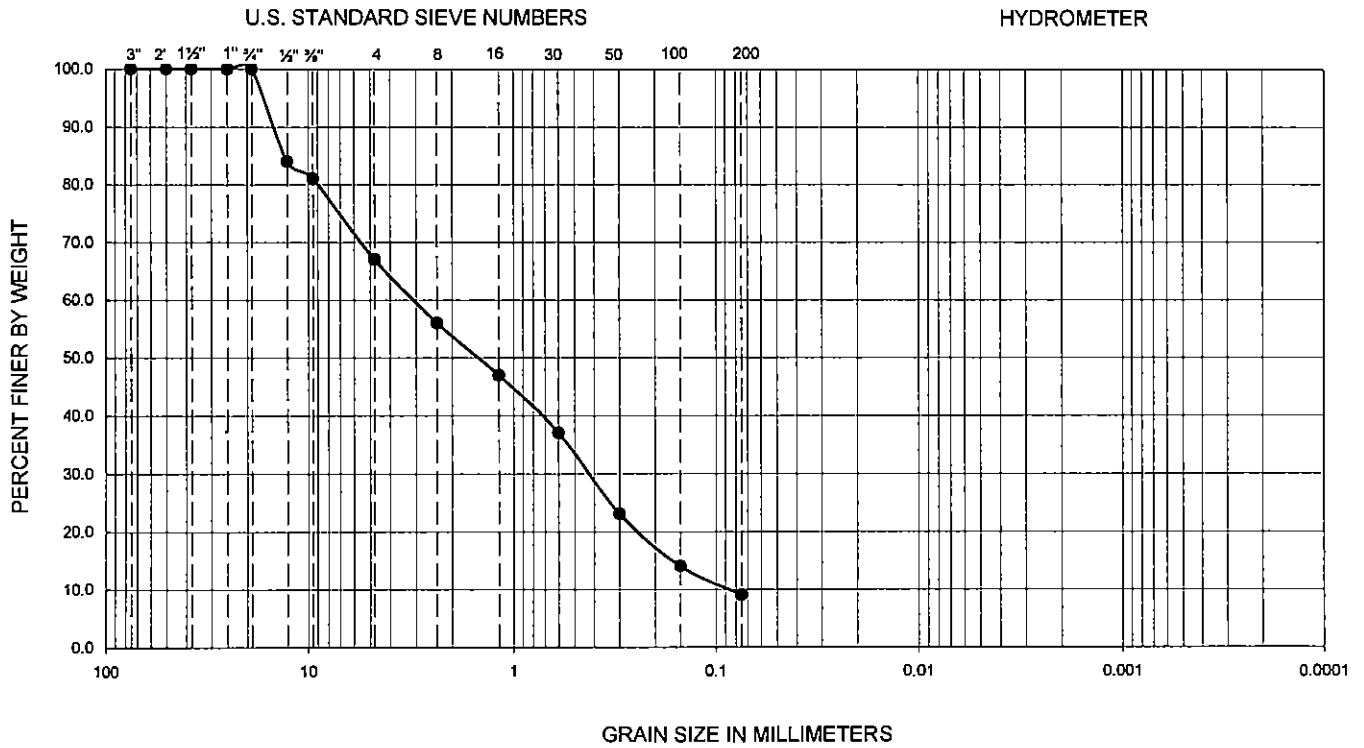

Symbol	Sample Location	Depth (ft)	Liquid Limit	Plastic Limit	Plasticity Index	D <sub>10</sub>	D <sub>30</sub>	D <sub>60</sub>	C <sub>u</sub>	C <sub>c</sub>	Passing No. 200 (%)	USCS
●	B-2	50.0-51.5	--	--	--	0.09	0.41	3.03	35.2	0.6	9	SP-SM

PERFORMED IN GENERAL ACCORDANCE WITH ASTM D 422-63 (02)

<b>Ninyo &amp; Moore</b>		<b>GRADATION TEST RESULTS</b>		FIGURE <b>B-5</b>
PROJECT NO.	DATE	Covina Irrigation Company 225 West Arrow Highway Glendora, California		
207296001	12/07			

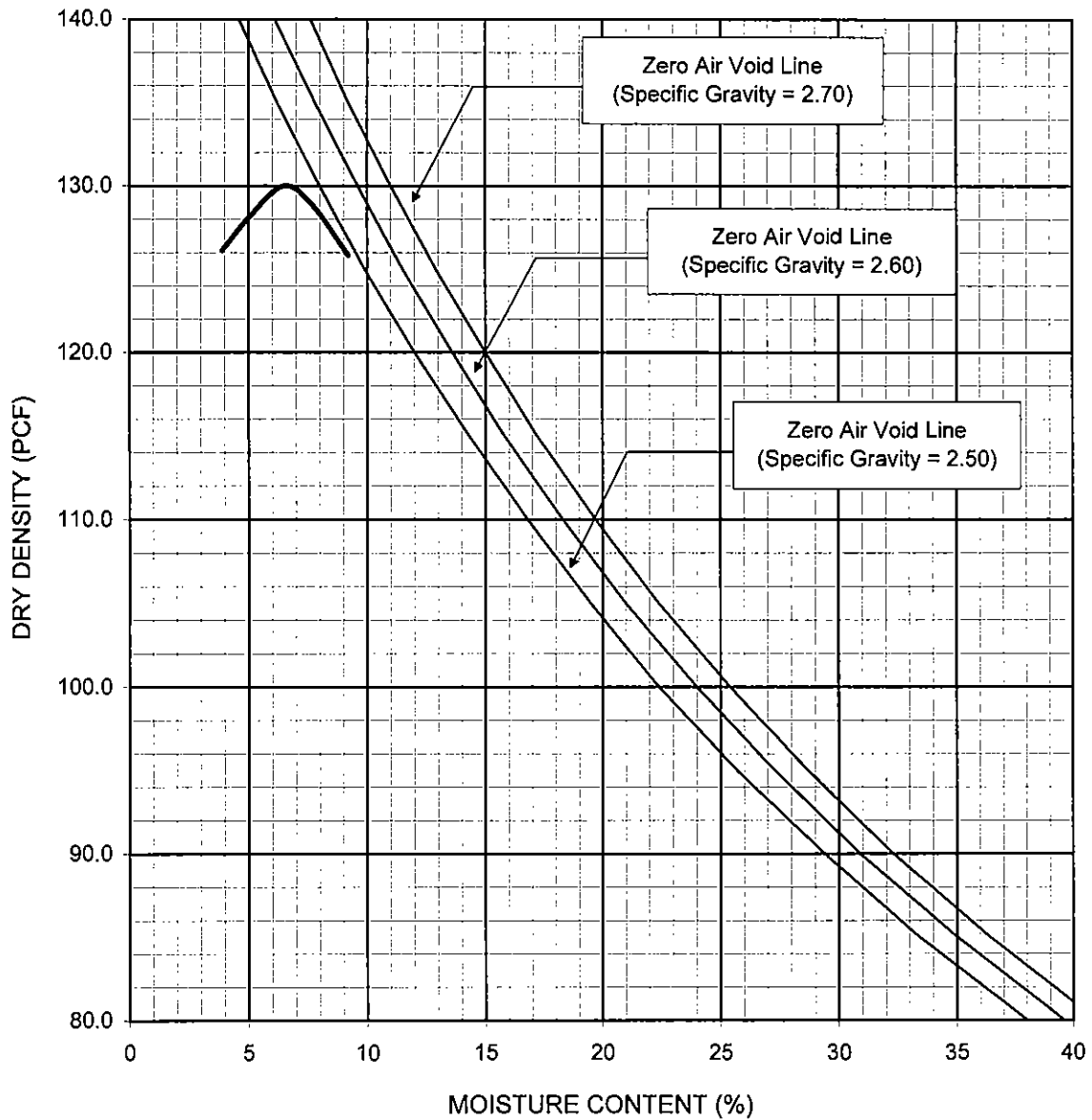

Sample Location	Depth (ft)	Soil Description	Maximum Dry Density (pcf)	Optimum Moisture Content (%)
B-1	1.5-5.0	Dark Grayish Brown Silty SAND with Gravel	130.0	6.5
Dry Density and Moisture Content Values Corrected for Oversize (ASTM D 4718-87)			132.0	6.0

PERFORMED IN GENERAL ACCORDANCE WITH  ASTM D 1557-02  ASTM D 698-00a METHOD  A  B  C

<b>Ninyo &amp; Moore</b>		<b>PROCTOR DENSITY TEST RESULTS</b>	FIGURE
PROJECT NO.	DATE	Covina Irrigation Company 225 West Arrow Highway Glendora, California	<b>B-6</b>
207296001	12/07		

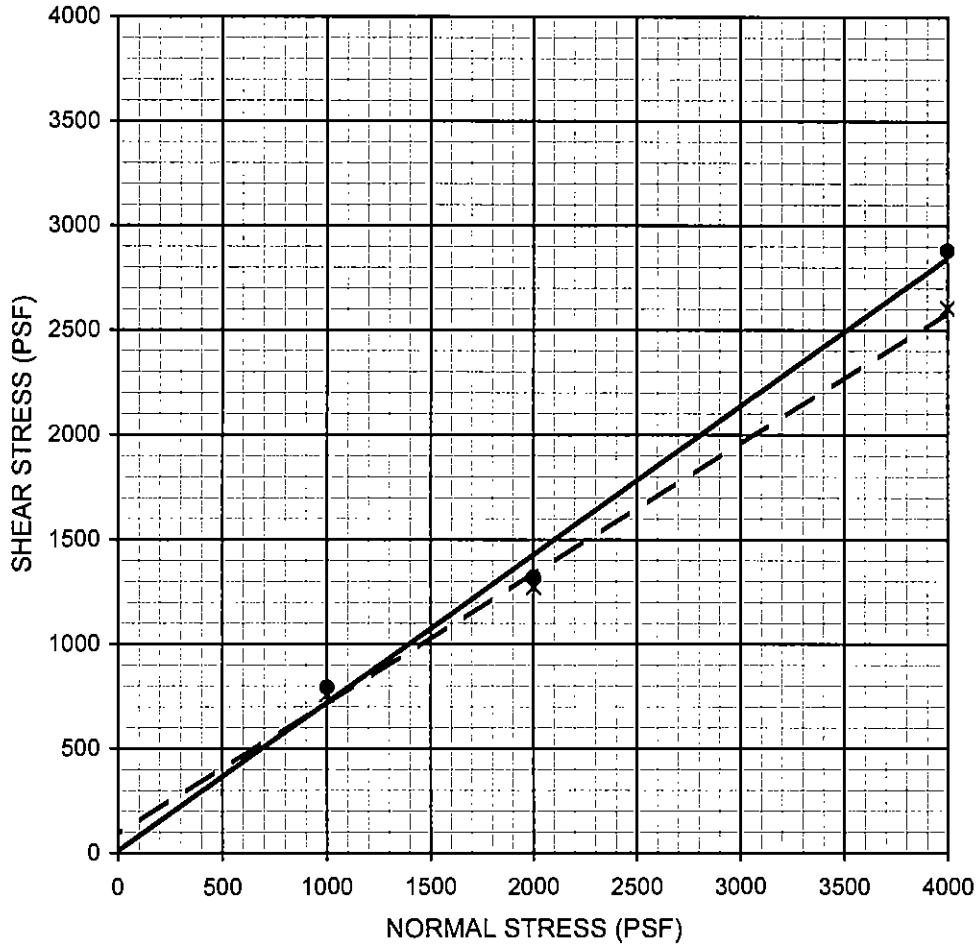

Description	Symbol	Sample Location	Depth (ft)	Shear Strength	Cohesion, c (psf)	Friction Angle, $\phi$ (degrees)	Soil Type
Silty SAND	—●—	B-1	1.5-5.0	Peak	12	35	SM
Silty SAND	- - X - -	B-1	1.5-5.0	Ultimate	90	32	SM

PERFORMED IN GENERAL ACCORDANCE WITH ASTM D 3080-04 ON A SAMPLE REMOLDED TO 90 PERCENT RELATIVE COMPACTION.

<b>Ninyo &amp; Moore</b>		<b>DIRECT SHEAR TEST RESULTS</b>	FIGURE <b>B-7</b>
PROJECT NO. 207296001	DATE 12/07		



SAMPLE LOCATION	SAMPLE DEPTH (FT)	pH <sup>1</sup>	RESISTIVITY <sup>1</sup> (Ohm-cm)	SULFATE CONTENT <sup>2</sup>		CHLORIDE CONTENT <sup>3</sup> (ppm)
				(ppm)	(%)	
B-1	1.5-5.0	9.0	6,700	150	0.015	70
B-2	0.4-5.0	8.0	3,285	100	0.010	140

<sup>1</sup> PERFORMED IN GENERAL ACCORDANCE WITH CALIFORNIA TEST METHOD 643

<sup>2</sup> PERFORMED IN GENERAL ACCORDANCE WITH CALIFORNIA TEST METHOD 417

<sup>3</sup> PERFORMED IN GENERAL ACCORDANCE WITH CALIFORNIA TEST METHOD 422

***Ninyo & Moore***

**CORROSIVITY TEST RESULTS**

FIGURE

PROJECT NO.

DATE

Covina Irrigation Company  
225 West Arrow Highway  
Glendora, California

207296001

12/07

**B-8**

To be filled out by P.M.

Project Number: 207296001

Project Name: Malcolm / Covina Irrigation Company

Author: MCP PM: JTB PIC: JV Size of Document (No. Pages): \_\_\_\_\_

Document Location: (Specify directory/file location if necessary) Folder file share Filename 207296001

Department: 04 Charge To General Office Or Other (Specify): Revised

Current Format: Word  Excel  LogDraft  Other  Specify: Excel

Document Type: Report  Letter  Proposal  Table  Logs  Form  PDF  CD  Specify How Many

For Proposal/WAAF PM Must Provide either the Proposal Authorization Form or the Client's Phone Number

WAAF Y  N  Schedule of Fees Y  N  (If Yes Specify #): \_\_\_\_\_ Estimated Breakdown of Fees Y  N

Client Phone No.: \_\_\_\_\_

Typical Earthwork Guidelines Slope  Flat  Metric  Pipeline

This Section to be filled out by P.M.

This Section to be filled out by W.P.

This Section to be filled out by P.M./Reviewer.

Date In:	Date Needed Back:	Word Processor:	Date Out:	Reviewer:	Date In	Date Needed Back	Reviewer's Initials	Elect. Sig. OK Initials Only	Date
11/19/07		MCP	11/20/07	DBC			DBC		11/29/07
11/21/07		JAD	11/21	CAP			JAD		11/30/07
11/22/07		JAD	11/27	JTB					
11/28/07		JAD	11/29						
12/3/07		MCP	12/3						

Additional WP Instructions/Comments:  
 The appendices have been created and are saved as "207296001 APPENDIX" in MCP > 207296001  
 11/29 Report in file share

Review Comments

Word Processing Check list	Current Styles/Format <input checked="" type="checkbox"/>	Dates <input checked="" type="checkbox"/>	Headers/Footers <input checked="" type="checkbox"/>	Spell Check <input checked="" type="checkbox"/>
Cover page styles/formatting <input type="checkbox"/>	Limitations Section <input type="checkbox"/>	References <input checked="" type="checkbox"/>	Numerical Usage <input checked="" type="checkbox"/>	SWL Check <input checked="" type="checkbox"/>
Include Boring Log Explanation Sheet & USGS Class <input type="checkbox"/>	Appendices <input checked="" type="checkbox"/>	Table of Contents <input checked="" type="checkbox"/>	First Usage <input checked="" type="checkbox"/>	
	PDF Draft <input type="checkbox"/>	PDF Final <input type="checkbox"/>	Mailing Label <input type="checkbox"/>	Fax Cover <input type="checkbox"/>

**Color Reproduction**

No. of Color Pages to be Copied \_\_\_\_\_ No. of Copies Per Page \_\_\_\_\_ Figures/Documents \_\_\_\_\_

**Regular Reproduction**

Number of Copies: \_\_\_\_\_ By: \_\_\_\_\_ Date: \_\_\_\_\_

Client Copy Review: \_\_\_\_\_ (PM or designee) Date: \_\_\_\_\_

Mail  Fax  Pick Up  Delivery  UPS  FED-EX  Other

Fax No.: \_\_\_\_\_ Other (Specify) \_\_\_\_\_



Geotechnical and Environmental Sciences Consultants

**SUPPLEMENTAL GEOTECHNICAL RECOMMENDATIONS  
COVINA IRRIGATION COMPANY  
TEMPLE WATER TREATMENT PLANT  
GLENDDORA, CALIFORNIA**

**PREPARED FOR:**  
Malcolm Pirnie, Inc.  
8001 Irvine Center Drive, Suite 1100  
Irvine, California 92618

**PREPARED BY:**  
Ninyo & Moore  
Geotechnical and Environmental Sciences Consultants  
475 Goddard, Suite 200  
Irvine, California 92618

March 17, 2009  
Revised April 30, 2009  
Project No. 207296001

March 17, 2009  
Revised April 30, 2009  
Project No. 207296001

Mr. Gregory S. Bazydola  
Malcolm Pirnie  
8001 Irvine Center Drive, Suite 1100  
Irvine, California 92618-2989

Subject: Supplemental Geotechnical Recommendations  
Covina Irrigation Company  
Temple Water Treatment Plant  
Glendora, California

Dear Mr. Bazydola:

In accordance with your request and authorization, we are providing supplemental geotechnical recommendations associated with the subject property located adjacent to West Arrow Highway, west of the intersection of Glendora Avenue and Arrow Highway in Glendora, California. This report presents supplemental recommendations regarding the design and construction of the proposed improvements.

We appreciate the opportunity to be of service on this project.

Respectfully submitted,  
**NINYO & MOORE**



James J. Barton, C.E.G.  
Senior Geologist

JJB/CAP/DC/mlc

Distribution: (4) Addressee

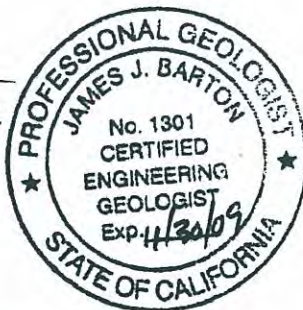

Daniel Chu, Ph.D., G.E.  
Chief Geotechnical Engineer



---

## TABLE OF CONTENTS

	<u>Page</u>
1. INTRODUCTION .....	1
2. SCOPE OF SERVICES .....	1
3. SITE CONDITIONS .....	2
4. FAULTING AND SEISMICITY .....	2
4.1. Ground Motion .....	3
5. CONCLUSIONS .....	4
6. RECOMMENDATIONS .....	4
6.1. Excavation Stability and Shoring .....	4
6.2. Seismic Design Considerations .....	6
6.3. Foundations.....	7
6.3.1. Shallow Footings.....	7
6.3.2. Lateral Earth Pressures.....	8
6.3.3. Mat Foundations .....	8
6.4. Slabs-on-Grade .....	9
6.5. Retaining Walls .....	9
6.5.1. Below-Grade Restrained Wall Adjacent to Existing Building .....	9
6.5.2. Yielding and Restrained Retaining Walls.....	10
7. LIMITATIONS.....	10
8. REFERENCES .....	12

### Tables

Table 1 – Principal Active Faults .....	3
Table 2 – 2007 California Building Code Seismic Design Criteria.....	6

### Figures

Figure 1 – Site Location Map	
Figure 2 – Boring Location Map	
Figure 3 – Lateral Earth Pressures for Braced Excavation	
Figure 4 – Lateral Earth Pressures for Restrained Below-Grade Retaining Walls	
Figure 5 – Lateral Earth Pressures for Yielding Retaining Walls	
Figure 6 – Lateral Earth Pressures for Restrained Retaining Walls	
Figure 7 – Retaining Wall Drainage Detail	

## 1. INTRODUCTION

In accordance with your request, we are providing supplemental geotechnical recommendations for the subject project located adjacent to the north side of West Arrow Highway, west of the intersection of Glendora Avenue and Arrow Highway in Glendora, California (Figure 1). We previously performed a geotechnical evaluation of the property for structures anticipated to be near the existing ground surface. The results of our previous evaluation were presented in the referenced report dated December 3, 2007. We understand that the new utility structure has changed from the time of our evaluation. The new structure will be supported below grade up to approximately 20 feet in depth. The new building will be adjacent to the existing Filtration Building. The purpose of our geotechnical consulting services was to review our previous work and prepare updated recommendations for the geotechnical aspects of the design and construction of the current planned improvements.

## 2. SCOPE OF SERVICES

Our scope of services will include the following:

- Review of our previous work pertinent to the subject property as well as the current plans for the improvements. In addition, we reviewed the existing foundations for the filtration building provided to us.
- Data compilation and engineering analysis of the information obtained from our review. Our engineering analyses and recommendations will include:
  - Review of site seismicity to provide Site-Specific Design Criteria per the 2007 California Building Code.
  - Analysis of the temporary stability of the trench excavations and shoring pressures, including allowable lateral earth pressures (static and dynamic) and allowable passive pressures as well as shoring the existing structure.
  - Evaluation of suitable foundation types including shallow footings and mat foundations with allowable bearing capacities, modulus of subgrade reaction, friction coefficient, and allowable passive pressures.
- Preparation of this supplemental geotechnical report for the site to present our findings, conclusions, and recommendations for the planned construction.

### 3. SITE CONDITIONS

The site is relatively flat with elevations ranging from approximately 676 feet above mean sea level (MSL) at the north end to approximately 674 feet at the south end. Based on a review of our previous work, the site is generally underlain at shallow depths by relatively dense alluvial sands and gravels. The alluvium is expected to contain some cobbles. Fill soils, consisting of medium dense silty sand and poorly graded sand, were encountered up to a depth of approximately 5 feet.

Groundwater was not encountered in our exploratory borings to a depth of approximately 51.5 feet at the time of drilling. Historical high groundwater near the site is approximately 200 feet below the ground surface (California Division of Mines and Geology [CDMG], 1998). It should be noted that fluctuations in groundwater level at the project site may occur due to variations in subsurface stratification, rainfall, irrigation practices, groundwater pumping, and other factors which may not have been evident at the time of our previous evaluation.

Based on our review of the foundation plans for the existing filtration building (James M. Montgomery, 1965), the area under the foundations was to be overexcavated up to approximately 10 feet below the existing ground surface. The excavation was to be backfilled to the underside of the floor slab and footings. Details regarding the limits and specific depths of the overexcavation and compaction of the backfill materials, if performed, are unknown.

The foundations for the existing filtration building were designed for conventional continuous and spread footings. The base of the foundations adjacent to the proposed utility structure reportedly varies from approximately 2½ to 6 feet below the ground surface (James M. Montgomery, 1965).

### 4. FAULTING AND SEISMICITY

Based on our previous work, no active fault traces are mapped underlying the site. Therefore, the potential for surface fault rupture is considered to be low. The subject site is not located within a State of California Earthquake Fault Zone (Alquist-Priolo Special Studies Zone, Hart and

Bryant, 1997). However, the site is located in a seismically active area, as is the majority of southern California, and the potential for strong ground motion in the project area is considered significant during the design life of the proposed improvements. Table 1 presents a summary of selected principal known active faults that may affect the site, the maximum moment magnitude ( $M_{max}$ ) as published by the California Geological Survey (CGS; Cao, et al., 2003). The approximate fault to site distance was calculated by the computer program FRISKSP (Blake, 2001b).

**Table 1 – Principal Active Faults**

<b>Fault</b>	<b>Approximate Fault to Site Distance miles (km)<sup>1</sup></b>	<b>Maximum Moment Magnitude<sup>2</sup> (<math>M_{max}</math>)</b>
Sierra Madre	3.2 (5.2)	7.2
San Jose	3.6 (5.8)	6.4
Cucamonga	8.0 (12.9)	6.9
Chino – Central Avenue (Elsinore)	8.6 (13.9)	6.7
Whittier	11.0 (17.7)	6.8
San Andreas	21.3 (34.2)	7.8
San Jacinto – San Bernardino	22.7 (36.5)	6.7
<b>Notes:</b> km – kilometers <sup>1</sup> Blake, 2001b <sup>2</sup> Cao, et al., 2003		

The conclusions regarding the principal seismic hazards presented in our December 3, 2007 report are generally applicable to the proposed construction. Updated ground motion parameters are presented in the following section.

#### **4.1. Ground Motion**

The 2007 California Building Code (CBC) recommends that the design of structures be based on the horizontal peak ground acceleration (PGA) having a 2 percent probability of exceedance in 50 years which is defined as the Maximum Considered Earthquake (MCE).



The statistical return period for  $PGA_{MCE}$  is approximately 2,475 years. The probabilistic  $PGA_{MCE}$  for the site was calculated as 0.83g for the site, using the United States Geological Survey (USGS, 2008) ground motion calculator (web-based). The design PGA was estimated to be 0.55g for the site. These estimates of ground motion do not include near-source factors that may be applicable to the design of structures on site.

## 5. CONCLUSIONS

Based on the review of our previous work and current plans, it is our opinion that the proposed improvements to the subject site are feasible from a geotechnical standpoint, provided that the recommendations presented in our report dated December 3, 2007, as well as the following recommendations, are incorporated into the design and construction of the project.

## 6. RECOMMENDATIONS

The following sections include our geotechnical recommendations for shoring and foundations for the proposed structures.

### 6.1. Excavation Stability and Shoring

We recommend that trenches and excavations be designed and constructed in accordance with Occupational Safety and Health Administration (OSHA) regulations. These regulations provide trench sloping and shoring design parameters for trenches up to 20 feet deep based on the soil types encountered. Trenches over 20 feet deep should be designed by the contractor's engineer based on site-specific geotechnical analyses. The soils at the site are generally fine to coarse granular soils with relatively little cohesion and a high potential for caving. For planning purposes, we recommend that on-site fill and alluvial soils be considered as OSHA soil Type C.

In our opinion, temporary slopes in the fill or alluvial soils should be stable at an inclination of approximately 1:1 (horizontal to vertical) up to a depth of about 4 feet. Excavations deeper than 4 feet should either be sloped at an inclination no steeper than 1.5:1 (horizontal to vertical) or shored. Some surficial sloughing may occur. In the area adjacent to the

existing building, temporary excavations should not be within 5 feet of the building. The project geotechnical engineer should evaluate these areas during grading operations and provide mitigation recommendations as needed.

Where temporary slopes are not possible, shoring will be appropriate. Shoring systems will be constructed through fill and alluvial deposits. The shoring system for the project may consist of trench shields or soldier pile-lagging wall or driven sheet piles. The shoring system should be designed using the lateral earth pressure values shown on Figure 3. The recommended design pressures are based on the assumptions that the shoring system is constructed without raising the ground surface elevation behind the shored sidewalls of the excavation, that there are no surcharge loads, such as soil stockpiles and construction materials, and that no loads act above a 1:1 (horizontal to vertical) plane ascending from the base of the shoring system, and that the shoring system is to be constructed at a distance of 5 feet or more from the edge of the footing for the adjacent building. For a shoring system subjected to the above-mentioned surcharge loads, the contractor should include the effect of these loads on the lateral earth pressures acting on the shored walls.

We anticipate that settlement of the ground surface will occur behind the shoring wall during excavation. The amount of settlement depends heavily on the type of shoring system, the contractor's workmanship, and soil conditions. To reduce the potential for distress to adjacent structures, we recommend that the shoring system be designed to limit the ground settlement behind the shoring system to ½ inch or less. Possible causes of settlement that should be addressed include settlement during installation of the shoring elements, excavation for structure construction, construction vibrations, dewatering, and removal of the support system. We recommend that shoring installation be evaluated carefully by the contractor prior to construction and that ground vibration and settlement monitoring be performed during construction. To reduce the potential for settlement associated with removal of shoring, the benefit of leaving the shoring elements buried in-place may be considered. We recommend that one inclinometer be installed adjacent to the excavations for the proposed structure. The depth of the inclinometer should extend a depth of 15 feet or

more below the bottom of excavation. The inclinometer should be read and data reviewed daily during excavation to evaluate potential movement. We recommend that structures/improvements in the vicinity (within 50 feet) of the planned shoring installation be reviewed with regard to foundation support and tolerance to settlement.

The contractor should retain a qualified and experienced engineer to design the shoring system. The shoring parameters presented in this report are minimum requirements, and the contractor should evaluate the adequacy of these parameters and make the appropriate modifications for their design. We recommend that the contractor take appropriate measures to protect workers. OSHA requirements pertaining to worker safety should be observed.

## 6.2. Seismic Design Considerations

Design of the proposed improvements should comply with design for structures located in Seismic Zone 4 and should be designed in accordance with the requirements of governing jurisdictions and applicable building codes. Table 2 presents the seismic design parameters for the site in accordance with CBC (2007) guidelines and mapped spectral acceleration parameters (United States Geological Survey [USGS], 2008).

**Table 2 – 2007 California Building Code Seismic Design Criteria**

Seismic Design Factor	Value
Site Class	D
Site Coefficient, $F_a$	1.0
Site Coefficient, $F_v$	1.5
Mapped Spectral Acceleration at 0.2-second Period, $S_s$	2.067g
Mapped Spectral Acceleration at 1.0-second Period, $S_1$	0.736g
Spectral Acceleration at 0.2-second Period Adjusted for Site Class, $S_{MS}$	2.067g
Spectral Acceleration at 1.0-second Period Adjusted for Site Class, $S_{M1}$	1.104g
Design Spectral Response Acceleration at 0.2-second Period, $S_{DS}$	1.378g
Design Spectral Response Acceleration at 1.0-second Period, $S_{D1}$	0.736g

### **6.3. Foundations**

Based on our understanding of the project, the proposed utility building and storage structures may be supported on shallow spread footings or mat foundations bearing on engineered fill compacted in accordance with the recommendations presented in the Earthwork section of our report dated December 3, 2007, or competent alluvial soil (in case of the below-grade utility structure). Foundations should be designed in accordance with structural considerations and the following recommendations. In addition, requirements of the appropriate governing jurisdictions and applicable building codes should be considered in the design of the structures.

#### **6.3.1. Shallow Footings**

Spread footings may be used to support the proposed structures. Footings should extend 24 inches or more below the lowest adjacent finished grade and have a width of 5 feet or greater. Footings, as described and bearing on compacted fill or competent alluvium, may be designed using an allowable bearing capacity of 3,000 psf. An additional allowable bearing pressure of 300 and 700 psf for each foot of width and depth increase, respectively, may be used to increase the allowable bearing pressure up to a maximum value of 5,000 psf. The allowable bearing pressure may be increased by up to one-third when considering loads of short duration, such as wind or seismic forces. Total and differential settlements for footings designed to sustain the recommended bearing pressures are estimated to be less than approximately 1 inch and ½ inch over a horizontal span of 40 feet, respectively.

Foundations should be reinforced in accordance with the recommendations of the project structural engineer. We recommend that, as a minimum, foundations be reinforced with two No. 4 reinforcing steel bars, one placed near the top of the footing and one placed near the bottom. Reinforcing bars should be covered by 3 or more inches of concrete.

### 6.3.2. Lateral Earth Pressures

Footings bearing on compacted fill or competent alluvium may be designed using a coefficient of friction of 0.35, where the total frictional resistance equals the coefficient of friction times the dead load. Foundations may be designed using a passive resistance value of 300 psf per foot of depth for a level ground condition. The allowable lateral resistance can be taken as the sum of the frictional resistance and passive resistance, provided the passive resistance does not exceed one-half of the total allowable resistance. The passive resistance (including the maximum value) may be increased by one-third when considering loads of short duration, such as wind or seismic forces.

### 6.3.3. Mat Foundations

Mat foundations for the below-grade utility structure may be designed using a net allowable bearing capacity of 5,000 pounds per square foot (psf) founded in competent alluvium or compacted fill. This allowable bearing pressure may be increased by one-third when considering loads of short duration such as wind or seismic forces. The total and differential settlements corresponding to this allowable bearing load are estimated to be less than approximately 1 inch and ½ inch over a horizontal span of 40 feet, respectively.

Mat foundations typically experience some deflection due to loads placed on the mat and the reaction of the soils directly underlying the mat. Mat foundations supported on competent alluvium or compacted fills may be designed using a coefficient of subgrade reaction,  $K_{v1}$ , of 150 tons per cubic foot (tcf). This value is based on a unit area of 1 square foot and should be adjusted for large mats. Adjusted value of the coefficient of subgrade reaction for a mat of a specific width,  $K_b$ , may be evaluated using the following equation:

$$K_b = K_{v1} [(b+1)/(2b)]^2 \text{ (tcf)}$$

where  $b$  is the least width of the foundation measured in feet. In addition, a coefficient of friction between concrete and subgrade of 0.35 can be used for design of the mat foundation.

#### **6.4. Slabs-on-Grade**

Slabs-on-grade should be supported on low expansion potential soil (i.e., Expansion Index of less than 50). The slabs should be designed for their specific loads and usage by the project structural engineer. We recommend that the slab be 5 inches thick and reinforced with No. 3 steel reinforcing bars placed at the midpoint of the slab and spaced at approximately 18 inches on-center both ways. The reinforcing bars should be placed on chairs. The floor slab should be constructed and reinforced in accordance with the recommendations of the structural engineer.

The floor slab should be underlain by a polyethylene vapor retarder, 10-mil or thicker, which is underlain, in turn, by a 2-inch-thick layer of clean sand. Soils underlying the slabs should be moisture conditioned and compacted in accordance with the recommendations contained in this report. Joints should be constructed at intervals designed by the structural engineer to help reduce random cracking of the slab.

#### **6.5. Retaining Walls**

##### **6.5.1. Below-Grade Restrained Wall Adjacent to Existing Building**

Below-grade retaining walls adjacent to the existing building may be considered to be restrained from lateral displacement under static loading conditions. Restrained walls subjected to lateral earth pressures from backfill soils and surcharges should be designed using the parameters presented on Figure 4. The dynamic lateral earth pressure parameters may be ignored for walls with a retained height of less than 12 feet (CBC, 2007).

The exterior of below-grade walls should be carefully waterproofed. We recommend that horizontal and vertical construction joints of below-grade structures have water stops to reduce the likelihood of water infiltration. For pipe penetrating into the structures, standard “water-tight” penetration design should be utilized. To reduce the potential for pipe-to-wall differential settlement, which could cause pipe shearing, we recommend that a flexible pipe joint be located close to the exterior of the wall. The type of joint should be such that minor relative movement can be accommodated without distress.

#### **6.5.2. Yielding and Restrained Retaining Walls**

Recommendations for lateral earth pressures to be used in design of the yielding and restrained retaining walls are provided on Figures 5 and 6, respectively. As indicated lateral soil resistance developed against lateral structural movement may be obtained using a passive pressure of 300 pounds per square foot per foot of depth for level backfill conditions. The passive value may be increased by one-third when considering loads of short duration, including wind and seismic loads. Further, for sliding resistance, a friction coefficient of 0.35 may be used for the concrete and soil interface. The allowable resistance may be taken as the sum of the frictional and passive resistance provided that the passive portion does not exceed one-half of the total allowable resistance. Retaining walls can be supported by footings with geotechnical design parameters as provided in section 6.3.1 of this report.

Measures should be taken to reduce the potential for build-up of moisture behind the retaining walls. Drainage design should include free draining backfill materials and perforated drains as described on Figure 7.

## **7. LIMITATIONS**

The evaluation and geotechnical analyses presented in this geotechnical report have been conducted in general accordance with current practice and the standard of care exercised by

geotechnical consultants performing similar tasks in the project area. No warranty, expressed or implied, is made regarding the conclusions, recommendations, and opinions presented in this report. There is no evaluation detailed enough to reveal every subsurface condition. Variations may exist and conditions not observed or described in this report may be encountered during construction. Uncertainties relative to subsurface conditions can be reduced through additional subsurface exploration. Additional subsurface evaluation will be performed upon request. Please also note that our evaluation was limited to assessment of the geotechnical aspects of the project, and did not include evaluation of structural issues, environmental concerns or the presence of hazardous materials.

This document is intended to be used only in its entirety. No portion of the document, by itself, is designed to completely represent any aspect of the project described herein. Ninyo & Moore should be contacted if the reader requires additional information or has questions regarding the content, interpretations presented, or completeness of this document.

Our conclusions, recommendations, and opinions are based on an analysis of the observed site conditions. If geotechnical conditions different from those described in this report are encountered, our office should be notified, and additional recommendations, if warranted, will be provided upon request. In the event of any changes in the nature, design, or locations of the proposed improvements, the conclusions and recommendations presented herein may not be valid unless the changes are evaluated by Ninyo & Moore and the conclusions of this report are modified in writing. It should be understood that the conditions of a site can change with time as a result of natural processes or the activities of man at the subject site or nearby sites. In addition, changes to the applicable laws, regulations, codes, and standards of practice may occur due to government action or the broadening of knowledge. The findings of this report may, therefore, be invalidated over time, in part or in whole, by changes over which Ninyo & Moore has no control.

This report is intended exclusively for use by the client. Any use or reuse of the findings, conclusions, and/or recommendations of this report by parties other than the client is undertaken at said parties' sole risk.



---

## 8. REFERENCES

- Blake, T.F., 2001a, UBCSEIS (Version 1.02), Computation of 1997 Uniform Building Code Seismic Design Parameters.
- Blake, T.F., 2001b, FRISKSP (Version 4.00), A Computer Program for the Probabilistic Estimation of Peak Acceleration and Uniform Hazard Spectra Using 3-D Faults as Earthquake Sources.
- California Building Code, 2001 Edition, based upon Uniform Building Code, 1997 Edition, dated May 1.
- California Department of Conservation, Division of Mines and Geology, State of California, 1998a, Maps of Known Active Fault Near-Source Zones in California and Adjacent Portions of Nevada: International Conference of Building Officials, dated February.
- California Department of Conservation, Division of Mines and Geology, State of California, 1998b, Seismic Hazard Evaluation of the San Dimas 7.5-Minute Quadrangle, Los Angeles County, California: Open-File Report 98-23.
- California Department of Conservation, Division of Mines and Geology, State of California, 1999, Seismic Hazard Zones Official Map, San Dimas Quadrangle, 7.5-Minute Series: Scale 1:24,000, Open-File Report 98-23, dated March 25.
- California Department of Transportation, 1991, NEWCON90, dated April 30.
- California Department of Transportation, 1995, Highway Design Manual, Fourth Edition.
- California Department of Transportation, 2003, Corrosion Guidelines, Version 1.0, dated September, Engineering Science, 1984, Miramar Water Treatment Plant, Site Grading and Piping Plan – West, Sheet C-0.2, dated October 30.
- Cao, Tianqing, Bryant, William A., Rowshandel, Badie, Branum, David, and Wills, Christopher J., 2003, The Revised 2002 California Probabilistic Seismic Hazard Maps, dated June.
- Dibblee, T.W., Jr., 2002, Geologic Map of the San Dimas and Ontario Quadrangles, Los Angeles and San Bernardino Counties, California: Dibblee Foundation, DF-91, Scale 1:24,000.
- Google Earth Pro, 2007, 225 West Arrow Highway, Glendora, California.
- Hart, E.W., and Bryant, W.A., 1997, Fault-Rupture Hazard Zones in California, Alquist-Priolo Earthquake Fault Zoning Act with Index to Earthquake Fault Zone Maps: California Department of Conservation, Division of Mines and Geology, Special Publication 42, with Supplements 1 and 2 added in 1999.
- International Conference of Building Officials, 1997, Uniform Building Code, dated May 1.

James M. Montgomery Consulting Engineers, Inc., 1965, Plans for Covina Irrigating Company, Water Treatment Plant, Sheets 1 through 8 of 25, dated December 15.

Jennings, C.W., 1994, Fault Activity Map of California and Adjacent Areas: California Division of Mines and Geology, California Geologic Data Map Series, Map No. 6, Scale 1:750,000.

Joint Cooperative Committee of the Southern California Chapter of the American Public Works Association and Southern California Districts of the Associated General Contractors of California, 2006, "Greenbook," Standard Specifications for Public Works Construction: BNI Building News, Los Angeles, California.

Malcolm Pirnie, 2009, Plans for Temple Water Treatment Plant, Sheet C-2, M-1, M-2, M-3, and M-4, dated April.

Morton, D.M., and Miller, F.K., 2003, Preliminary Geologic Map of The San Bernardino 30' x 60' Quadrangle, California, Version 1.0: United States Geological Survey Open-File Report 03-293, Scale 1:100,000.

Ninyo & Moore, Unpublished and Proprietary In-house Data.

Ninyo & Moore, 2007, Proposal for Geotechnical Consulting Services, Covina Irrigation Company, 225 West Arrow Highway, Glendora, California, dated October 8.

Ninyo & Moore, 2007, Geotechnical Evaluation, Covina Irrigation Company, 225 West Arrow Highway, Glendora, California, Project No. 207296001, dated December 3.

Peterson, M.D., Bryant, W.A., Cramer, C.H., Cao, T., Reichle, M.S., Frankel, A.D., Lienkaemper, J.J., McCrory, P.A., and Schwartz, D.P., 1996, Probabilistic Seismic Hazard Assessment for the State of California: California Department of Conservation, Division of Mines and Geology Open File Report 96-08.

Sydnor, R.H., 2004, Checklist for the Review of Engineering Geology and Seismology Reports for California Public Schools, Hospitals, and Essential Services Buildings: California Geological Survey, Note 48, dated January 1.

United States Geological Survey, 1967 (Photorevised 1981), San Dimas, California Quadrangle Map, 7.5 Minute Series: Scale 1:24,000.

<b>AERIAL PHOTOGRAPHS</b>				
<b>Source</b>	<b>Date</b>	<b>Scale</b>	<b>Flight</b>	<b>Numbers</b>
USDA	1-2-53	1:20,000	AXJ-9K	80 and 82

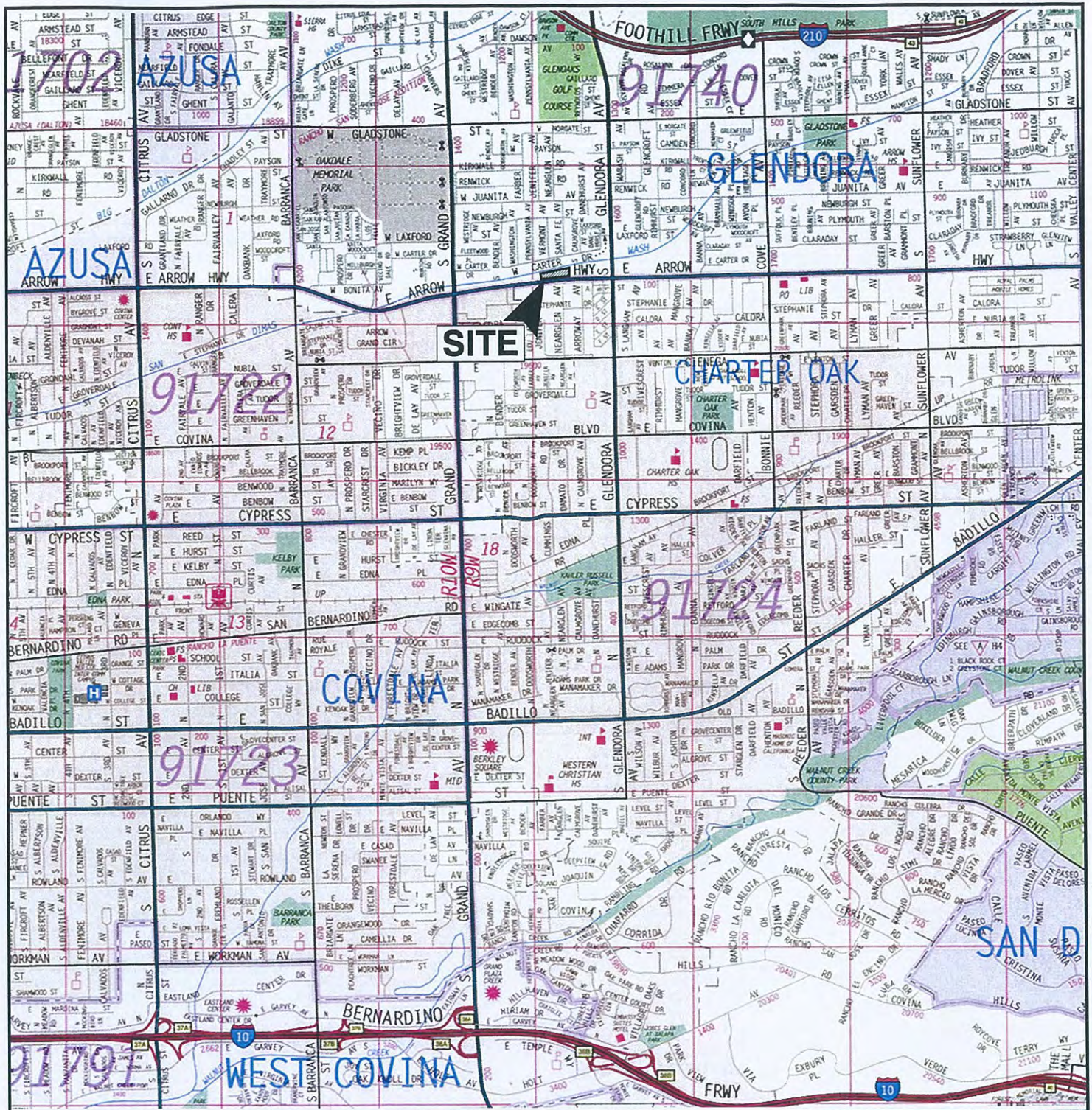

REFERENCE: 2005 THOMAS GUIDE FOR LOS ANGELES/ORANGE COUNTIES, STREET GUIDE AND DIRECTORY

APPROXIMATE SCALE IN FEET

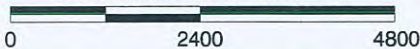

NOTE: ALL DIMENSIONS, DIRECTIONS AND LOCATIONS ARE APPROXIMATE.



**Ninyo & Moore**

**SITE LOCATION MAP**

FIGURE

PROJECT NO.

DATE

COVINA IRRIGATION COMPANY  
TEMPLE WATER TREATMENT PLANT  
GLENDDORA, CALIFORNIA

207296001

4/09

**1**

207296-A4.DWG

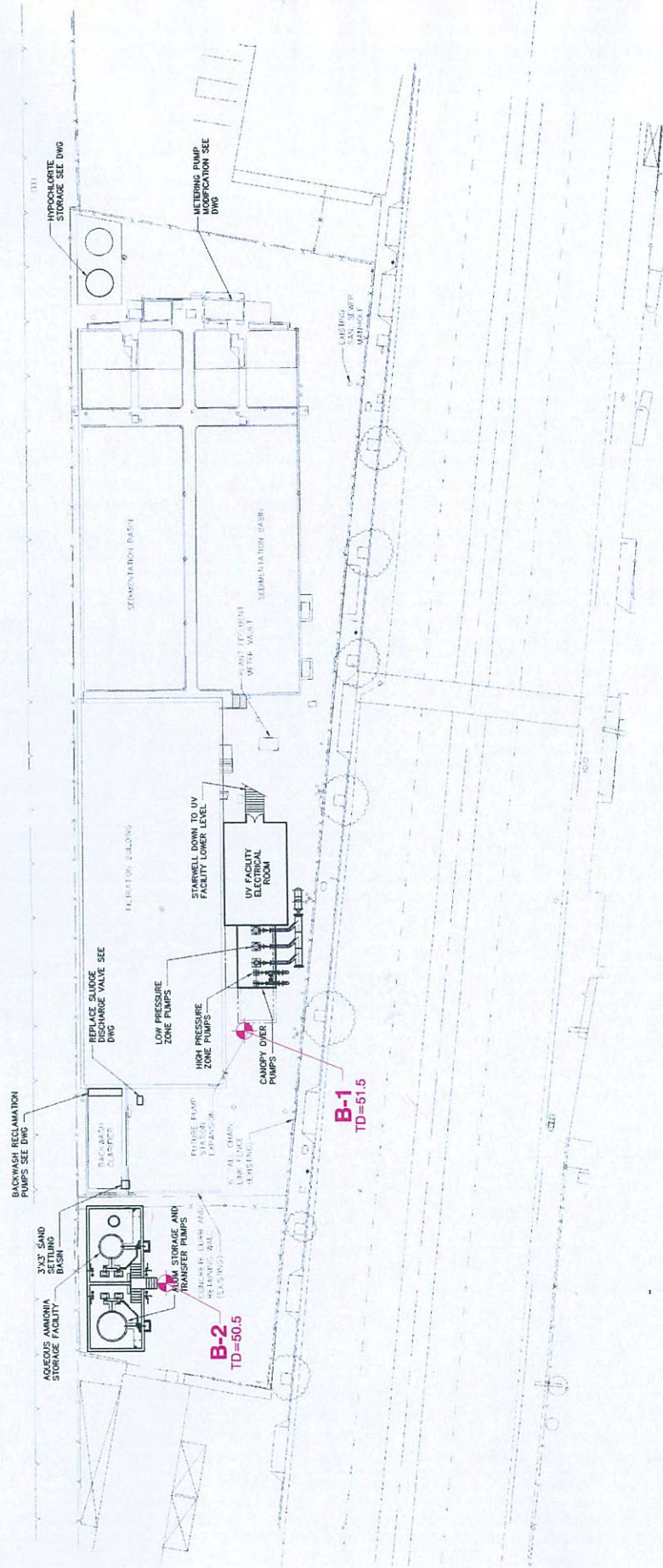

**LEGEND**

**B-2** APPROXIMATE LOCATION OF EXPLORATORY BORING  
 TD=60.5 TD=TOTAL DEPTH IN FEET

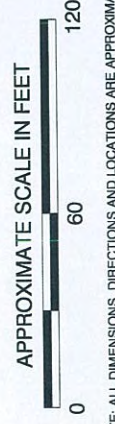

NOTE: ALL DIMENSIONS, DIRECTIONS AND LOCATIONS ARE APPROXIMATE.

REFERENCE: MALCOLM PIRNIE, 2009, SURFACE IMPROVEMENTS PLAN, SHEET 2, APRIL.

**Ninyo & Moore**

**BORING LOCATION MAP**

COVINA IRRIGATION COMPANY  
 TEMPLE WATER TREATMENT PLANT  
 GLENDORA, CALIFORNIA

PROJECT NO.	DATE
207296001	4/09

FIGURE

**2**

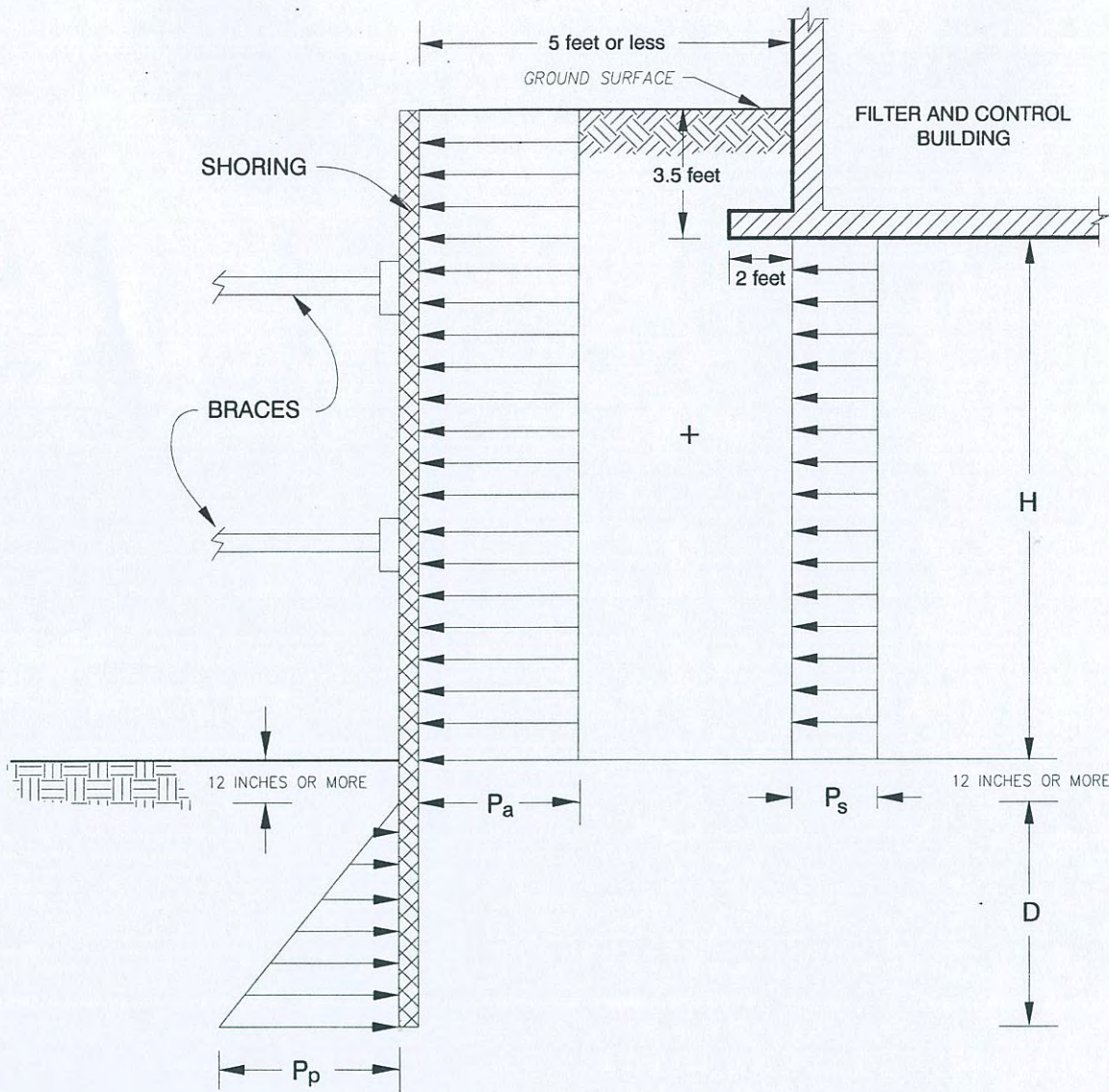

NOTES:

1. APPARENT LATERAL EARTH PRESSURE,  $P_a$   
 $P_a = 21H$  psf
2. ADJACENT FOUNDATION INDUCED SURCHARGE PRESSURE,  $P_s$   
 $P_s = 500$  psf
3. PASSIVE LATERAL EARTH PRESSURE,  $P_p$   
 $P_p = 400 D$  psf
4. ASSUMES GROUNDWATER IS NOT PRESENT
5. SURCHARGES FROM EXCAVATED SOIL OR CONSTRUCTION MATERIALS ARE NOT INCLUDED
6. H AND D ARE IN FEET

NOT TO SCALE

**Ninyo & Moore**

**LATERAL EARTH PRESSURES FOR BRACED EXCAVATION (GRANULAR SOIL)**

FIGURE

PROJECT NO.

DATE

COVINA IRRIGATION COMPANY  
TEMPLE WATER TREATMENT PLANT  
GLEN DORA, CALIFORNIA

**3**

207296001

4/09

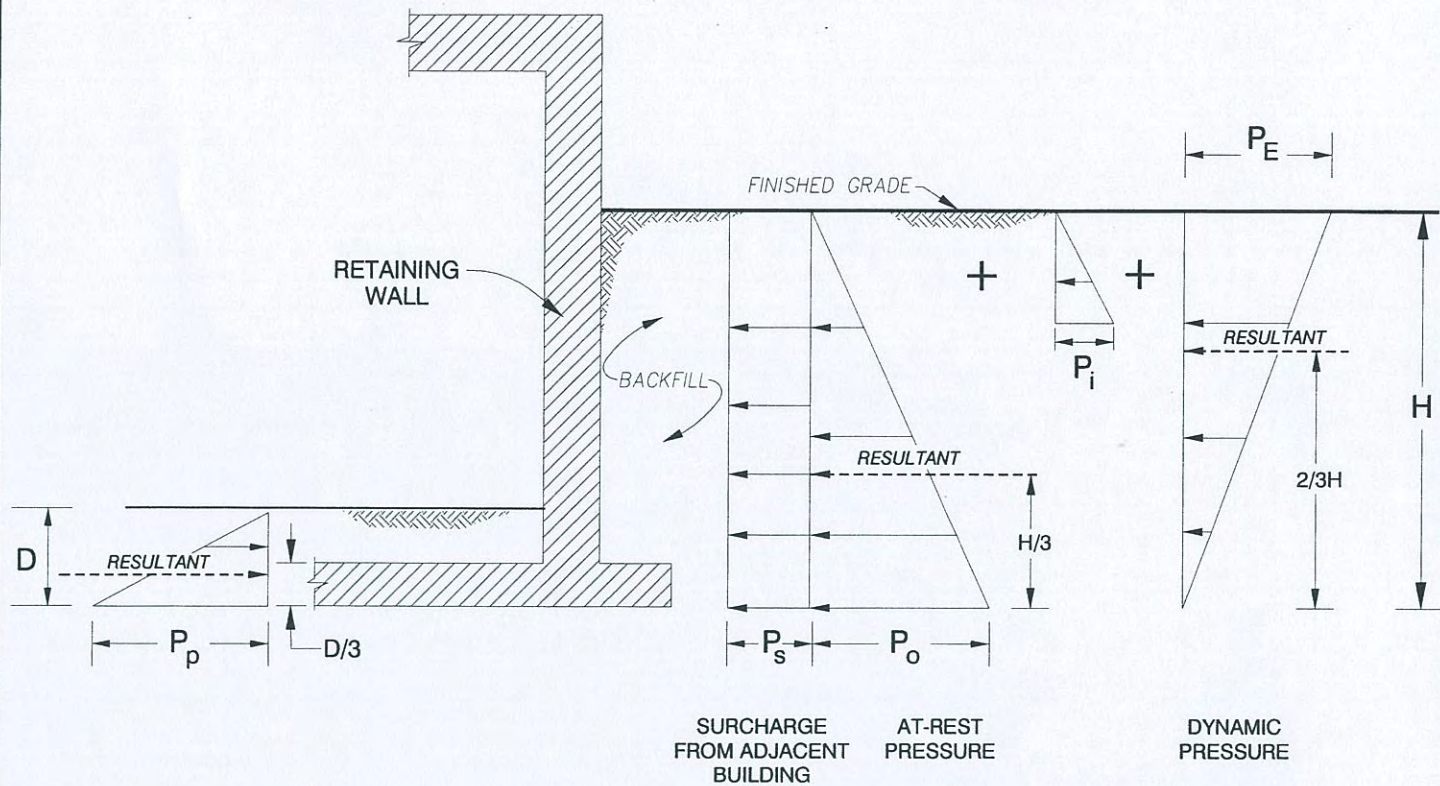

NOTES:

1. ASSUMES NO HYDROSTATIC PRESSURE BUILD-UP BEHIND THE RETAINING WALL
2. DYNAMIC LATERAL EARTH PRESSURE ARE BASED ON PEAK GROUND ACCELERATION OF 0.55g
3. H AND D ARE IN FEET
4. A SOIL UNIT WEIGHT OF 120 pcf IS USED IN THE ANALYSIS

RECOMMENDED GEOTECHNICAL DESIGN PARAMETERS

Lateral Earth Pressure	Equivalent Fluid Pressure (lb/ft <sup>2</sup> ) <sup>(1)</sup>
$P_o$	51 H
$P_e$	23 H
$P_s$	700
$P_i$	1050
$P_p$	300 D

NOT TO SCALE

207296-A6.DWG

**Ninyo & Moore**

**LATERAL EARTH PRESSURES FOR RESTRAINED RETAINING WALLS**

FIGURE

PROJECT NO.

DATE

COVINA IRRIGATION COMPANY  
TEMPLE WATER TREATMENT PLANT  
GLEN DORA, CALIFORNIA

207296001

4/09

**4**

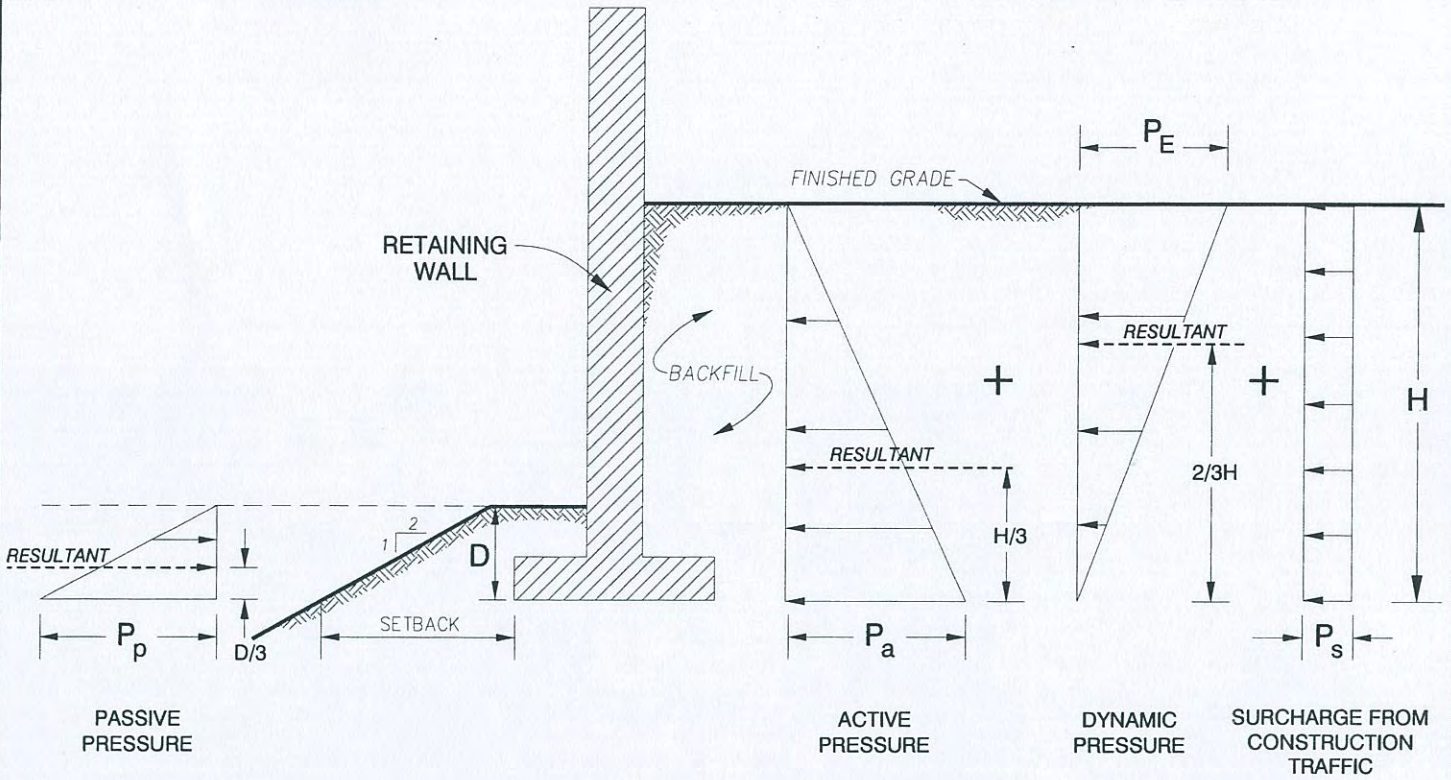

NOTES:

1. ASSUMES NO HYDROSTATIC PRESSURE BUILD-UP BEHIND THE RETAINING WALL
2. STRUCTURAL, GRANULAR BACKFILL MATERIALS AS SPECIFIED IN GREENBOOK SHOULD BE USED FOR RETAINING WALL BACKFILL
3. DRAINS AS RECOMMENDED IN THE RETAINING WALL DRAINAGE DETAIL SHOULD BE INSTALLED BEHIND THE RETAINING WALL
4. DYNAMIC LATERAL EARTH PRESSURE IS BASED ON A PEAK GROUND ACCELERATION OF 0.55g
5. H AND D ARE IN FEET
6. SETBACK SHOULD BE IN ACCORDANCE WITH FIGURE 1805.3.1 OF THE CBC (2007)

RECOMMENDED GEOTECHNICAL DESIGN PARAMETERS

Lateral Earth Pressure	Equivalent Fluid Pressure (lb/ft <sup>2</sup> /ft) <sup>(1)</sup>	
	Level Backfill with Granular Soils <sup>(2)</sup>	2H:1V Sloping Backfill with Granular Soils <sup>(2)</sup>
P <sub>a</sub>	33 H	47 H
P <sub>E</sub>	23 H	23 H
P <sub>p</sub>	Level Ground	2H:1V Descending Ground
	300 D	170 D
P <sub>s</sub>	120 psf	120 psf

NOT TO SCALE

**Ninyo & Moore**

**LATERAL EARTH PRESSURES FOR YIELDING RETAINING WALLS**

FIGURE

PROJECT NO.

DATE

207296001

4/09

COVINA IRRIGATION COMPANY  
TEMPLE WATER TREATMENT PLANT  
GLEN DORA, CALIFORNIA

**5**

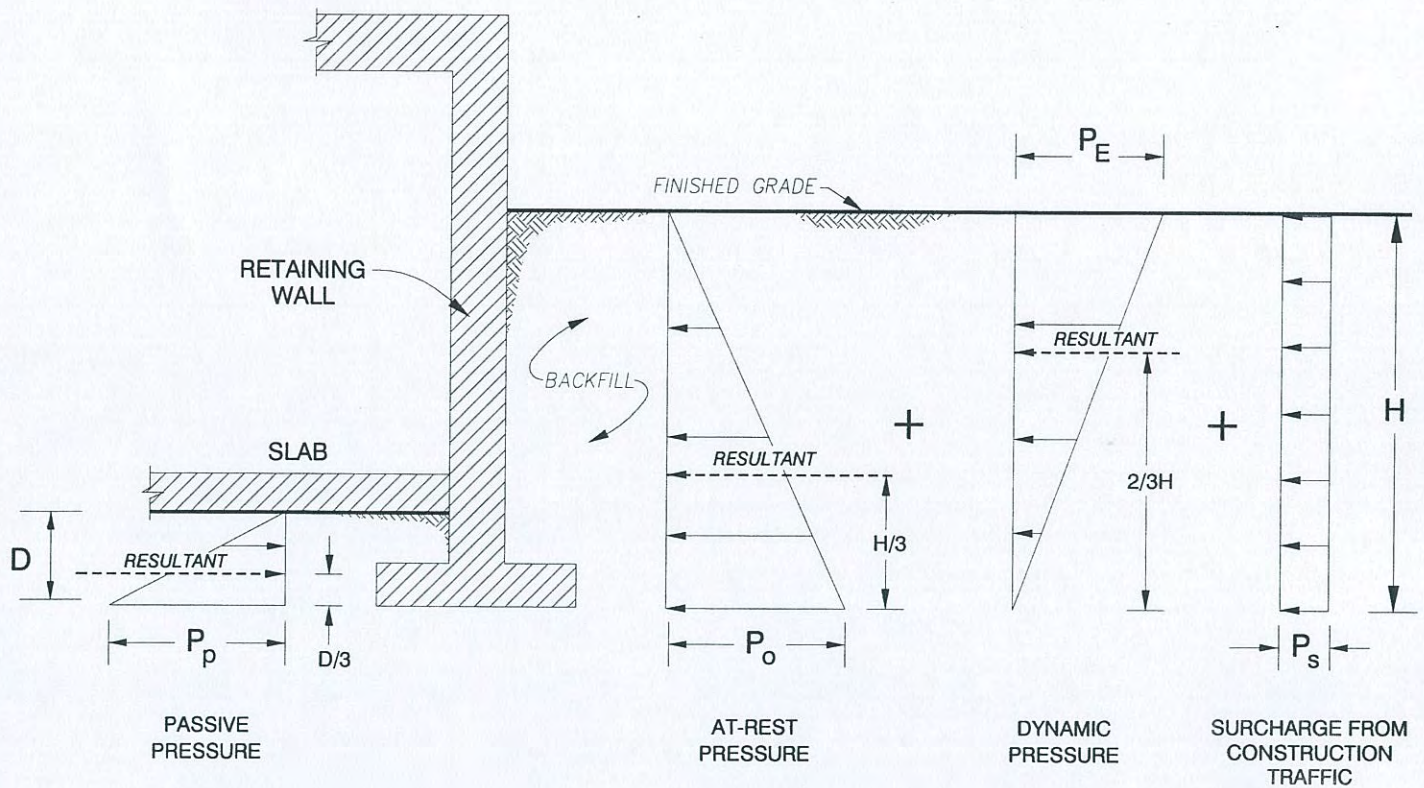

**NOTES:**

1. ASSUMES NO HYDROSTATIC PRESSURE BUILD-UP BEHIND THE RETAINING WALL
2. STRUCTURAL, GRANULAR BACKFILL MATERIALS AS SPECIFIED IN GREENBOOK SHOULD BE USED FOR RETAINING WALL BACKFILL
3. DRAINS AS RECOMMENDED IN THE RETAINING WALL DRAINAGE DETAIL SHOULD BE INSTALLED BEHIND THE RETAINING WALL
4. DYNAMIC LATERAL EARTH PRESSURE IS BASED ON A PEAK GROUND ACCELERATION OF 0.55g
5. H AND D ARE IN FEET

**RECOMMENDED GEOTECHNICAL DESIGN PARAMETERS**

Lateral Earth Pressure	Equivalent Fluid Pressure (lb/ft <sup>2</sup> /ft) <sup>(1)</sup>	
	Level Backfill with Granular Soils <sup>(2)</sup>	2H:1V Sloping Backfill with Granular Soils <sup>(2)</sup>
P <sub>O</sub>	51 H	N.A.
P <sub>E</sub>	23 H	N.A.
P <sub>P</sub>	Level Ground	2H:1V Descending Ground
	300 D	N.A.
P <sub>S</sub>	120 psf	N.A.

NOT TO SCALE

207296\_A9.DWG

<b>Ninyo &amp; Moore</b>		<b>LATERAL EARTH PRESSURES FOR RESTRAINED RETAINING WALLS</b>	FIGURE
PROJECT NO.	DATE	COVINA IRRIGATION COMPANY TEMPLE WATER TREATMENT PLANT GLENDDORA, CALIFORNIA	<b>6</b>
207296001	4/09		



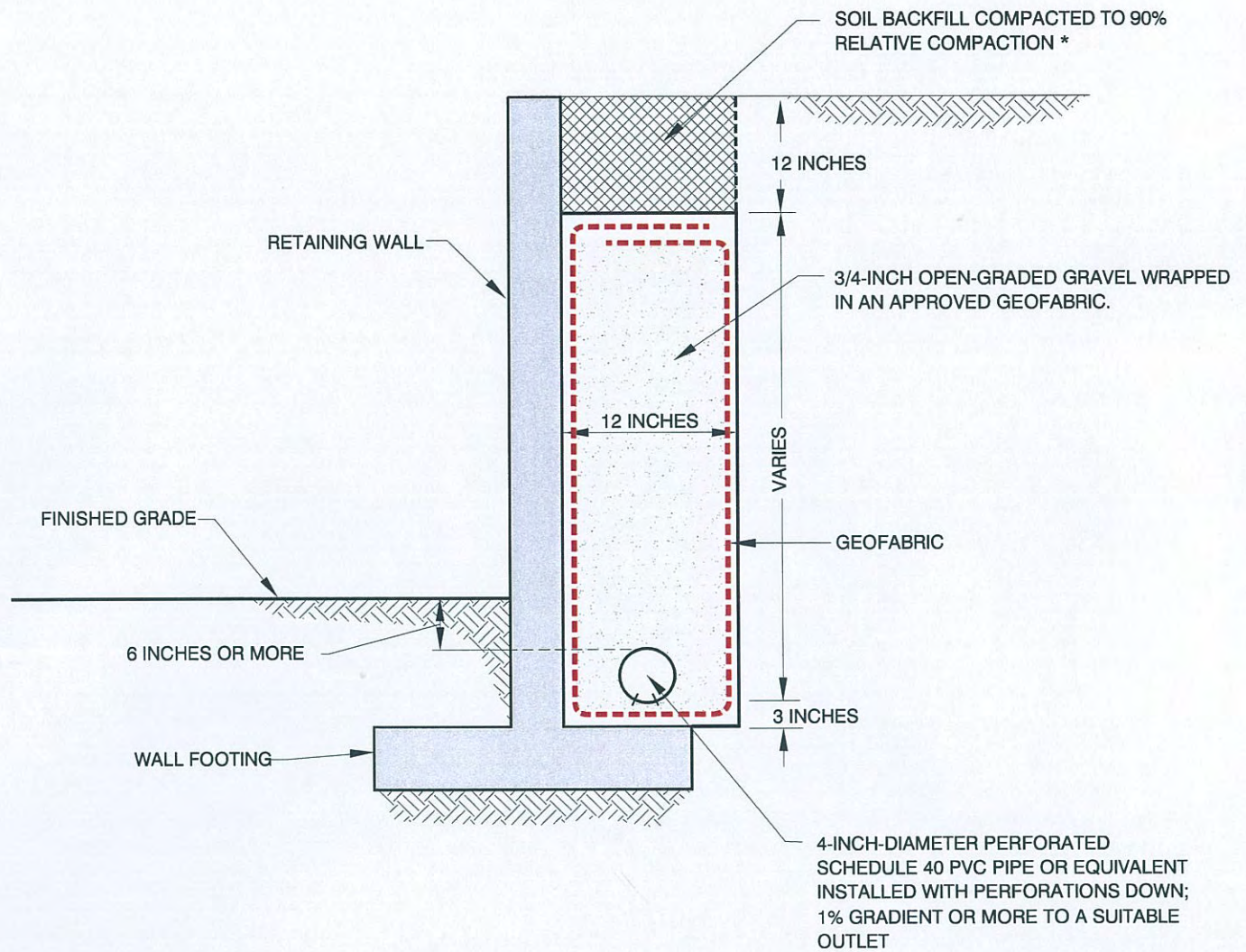

\*BASED ON ASTM D1557

NOT TO SCALE

NOTE: AS AN ALTERNATIVE, AN APPROVED GEOCOMPOSITE DRAIN SYSTEM MAY BE USED.

207296\_A10.DWG

**Ninyo & Moore**

**RETAINING WALL DRAINAGE DETAIL**

FIGURE

PROJECT NO.

DATE

COVINA IRRIGATION COMPANY  
TEMPLE WATER TREATMENT PLANT  
GLENDDORA, CALIFORNIA

207296001

4/09

**7**

# APPENDIX H

## Central Los Angeles County Regional Water Recycling Program – Los Angeles Department of Water and Power

# Technical Memorandum

---

## Central Los Angeles County Regional Water Recycling Project

**Subject:** Project Concept  
**Prepared For:** GWP, LADWP, PWP, FMWD  
**Prepared by:** Rob Morrow  
**Reviewed by:** Tom Richardson  
**Date:** November 6, 2007

---

### Summary

The Los Angeles-Glendale Water Reclamation Plant (LAGWRP) produces over 17,000 acre-feet per year (afy) of tertiary treated water for use by Glendale Water and Power (GWP), Los Angeles Department of Water and Power (LADWP) and Pasadena Water and Power (PWP). Currently, less than 4,000 afy is beneficially used by GWP and LADWP to meet non-potable water demands.

GWP, LADWP, and PWP, along with the Foothill Municipal Water District (FMWD), partnered to develop a project concept to maximize the beneficial uses of this additional 13,500 afy of recycled water. This technical memorandum (TM) identifies the components, phases, and benefits of this project, hereinafter referred to as the *Central Los Angeles County (CeLAC) Regional Water Recycling Project (RWRP)*.

Key characteristics of this project include:

- **Partner agencies** - GWP, LADWP, PWP, FMWD
- **Regional Coordination** - Provides recycled water to a wide geographic area spanning East Los Angeles, Glendale, Pasadena, and Crescenta Valley.
- **Water Supply Reliability** - Uses an additional 13,500 afy of recycled water offsetting current potable demand.
- **Water Recycling** - Enhances efficiency of LAGWRP relative to beneficial use of treated effluent.
- **Wastewater Management** - Reduces amount of wastewater flowing via interceptor sewers to Hyperion Wastewater Treatment Plant.
- **Stormwater Management** - Supports stormwater management initiatives in Pasadena's Arroyo Seco and Eaton Wash.
- **LA River Water Quality** - Advanced treatment component provides a mechanism to improve quality of effluent discharged to the LA River.
- **Groundwater Quality** - project provides a mechanism to improve salinity balance in the Raymond Groundwater Basin

**Table S-1** presents the proposed regional project phases broken down by agency. **Figure S-1** presents annual recycled water use by agency for each phase. The increased beneficial use of recycled water from less than 25% to over 80% of the LAGWRP production potential through the project phases is demonstrated in. **Figure S-2** presents the proposed CeLAC RWRP phases.

Table S-1: Recommended Regional Recycled Water Project Phases by Agency

Project Phase	GWP Projects (afy)	LADWP Projects (afy)	PWP Projects (afy)	Total (afy)		
<b>Existing</b>	<b>2,120</b>	<b>1,920</b>	<b>-</b>	<b>4,040</b>		
<b>Phase 1 (~2010)</b>	Glendale Tee	450	LA Zoo	700	Alternative A	730
			Elysian Park <sup>1</sup>	400		
			NBC-Universal	430		
			Other	540		
	<b>Subtotal</b>	<b>450</b>	<b>2,070</b>	<b>730</b>	<b>3,250</b>	
<b>Phase 2 (~2015)</b>	Extensions	200	Remaining Tier 1	1,130	Arroyo Seco GWR	2,000
					Huntington + Spurs	630
					Mountain View	270
					Devil's Gate Area	210
	<b>Subtotal</b>	<b>200</b>	<b>1,130</b>	<b>3,110</b>	<b>4,440</b>	
<b>Phase 3 (~2020)</b>	Extensions	100	Remaining Tier 2 (Alt 1)	2,600	Eaton Wash GWR	3,000
					Altadena G.C.	170
	<b>Subtotal</b>	<b>100</b>	<b>2,600</b>	<b>3,170</b>	<b>5,870</b>	
<b>Total New Use</b>	<b>750</b>	<b>5,800</b>	<b>7,010</b>	<b>13,560</b>		
<b>Total Use from LAGWRP</b>	<b>2,870</b>	<b>7,720</b>	<b>7,010</b>	<b>17,600</b>		

Note:

- The Taylor Yard portion of the Elysian Park project is near the start of construction, therefore, the demand (150 afy) and costs were not included in Phase 1 (or subsequent phases). The demand is included in Existing demands.

Figure S-1: Projected Use of Recycled Water by Agency (afy)

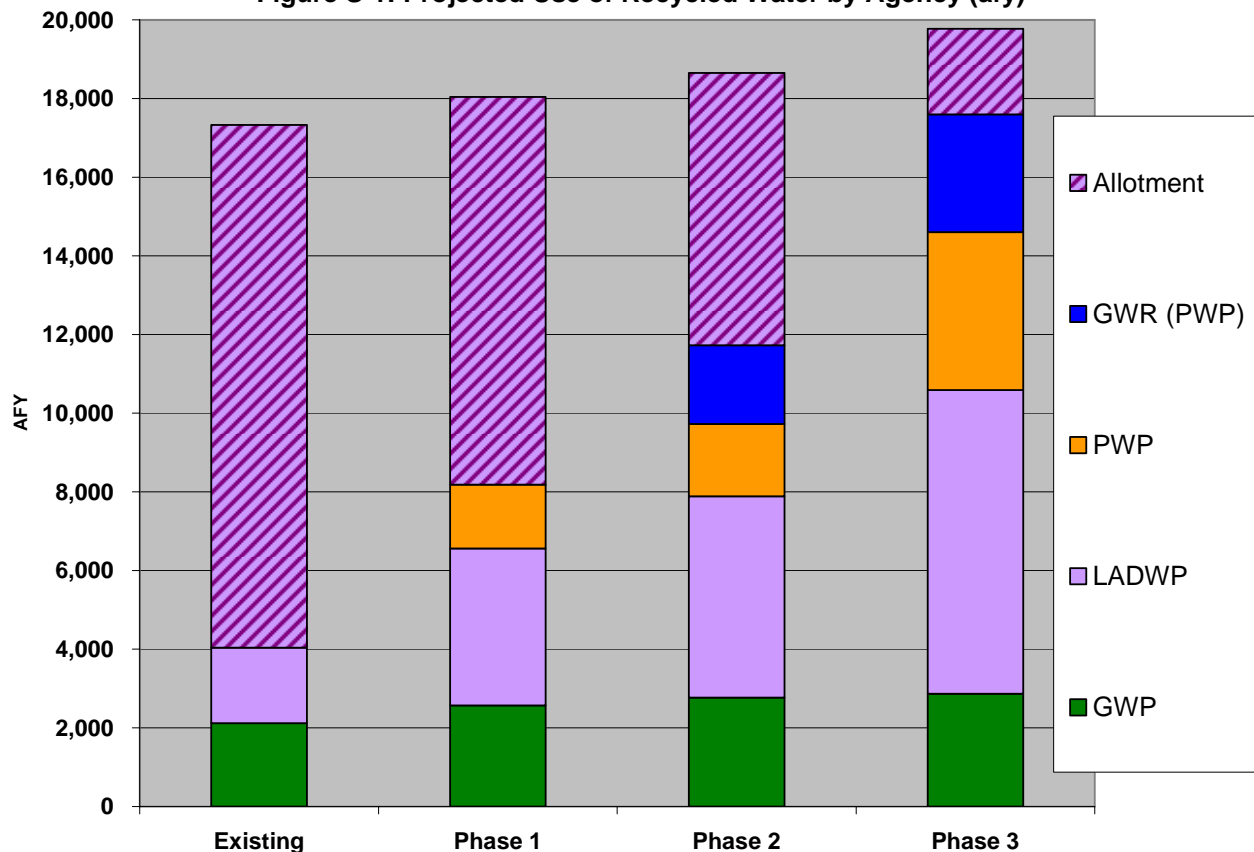

Note: GWR projections are for recharge in the PWP service area but are not included in PWP projections.



## 1 Introduction

Glendale Water and Power (GWP), Los Angeles Department of Water and Power (LADWP), Pasadena Water and Power (PWP) and Crescenta Valley Water District<sup>1</sup> (CVWD) recently completed recycled water planning studies to expand the beneficial use of recycled water produced from Los Angeles-Glendale Water Reclamation Plant (LAGWRP). These studies, and their respective conclusions, are included in Appendix B. The study area is presented in **Figure 1**.

This TM reassesses the recommendations drawn in each individual study by identifying inter-regional and seasonal coordination opportunities among these partner agencies to develop a project concept for the *Central Los Angeles County (CeLAC) Regional Water Recycling Project (RWRP)*<sup>2</sup>. Further, this TM facilitated thought and discussion among the project partners by providing a forum to conduct a technical fatal flaw analysis and to devise project operational strategies (such as flow balancing). The objectives of the TM are to provide the following:

- Project components, potential phasing, and preliminary cost estimates
- Project benefits and beneficiaries
- Project description for consideration in the Integrated Regional Water Management (IRWM) process and IRWM stakeholders
- Basis to seek planning and implementation grant and loan funding

This TM is organized as follows:

1. Introduction
2. Recycled Water Supply
3. Non-Potable Demand Assessment
4. Groundwater Recharge with Recycled Water Assessment
5. Recommended Project Concept
6. Implementation Plan

## 2 Recycled Water Supply

This section summarizes LAGWRP characteristics.

### 2.1 LAGWRP Ownership and Operations

LAGWRP started operations as the first water reclamation plant in Los Angeles in 1976. The plant is owned by GWP and the City of Los Angeles and is operated by Los Angeles Department of Public Works (LADPW). Each agency pays 50% of the costs and is entitled to 50% of any effluent. Recently, PWP signed an agreement with GWP for 60% of GWP's entitlement, which is equivalent 30% of the total plant effluent.

---

<sup>1</sup> CVWD is a member agency of Foothill Municipal Water District, who contributed to the funding of this TM along with GWP, LADWP, and PWP.

<sup>2</sup> The IRWM project database contains a description for this project [Central Los Angeles County (CeLAC) Regional Water Recycling Project] and a purpose of this TM is to further develop this description.

Figure 1: Study Area

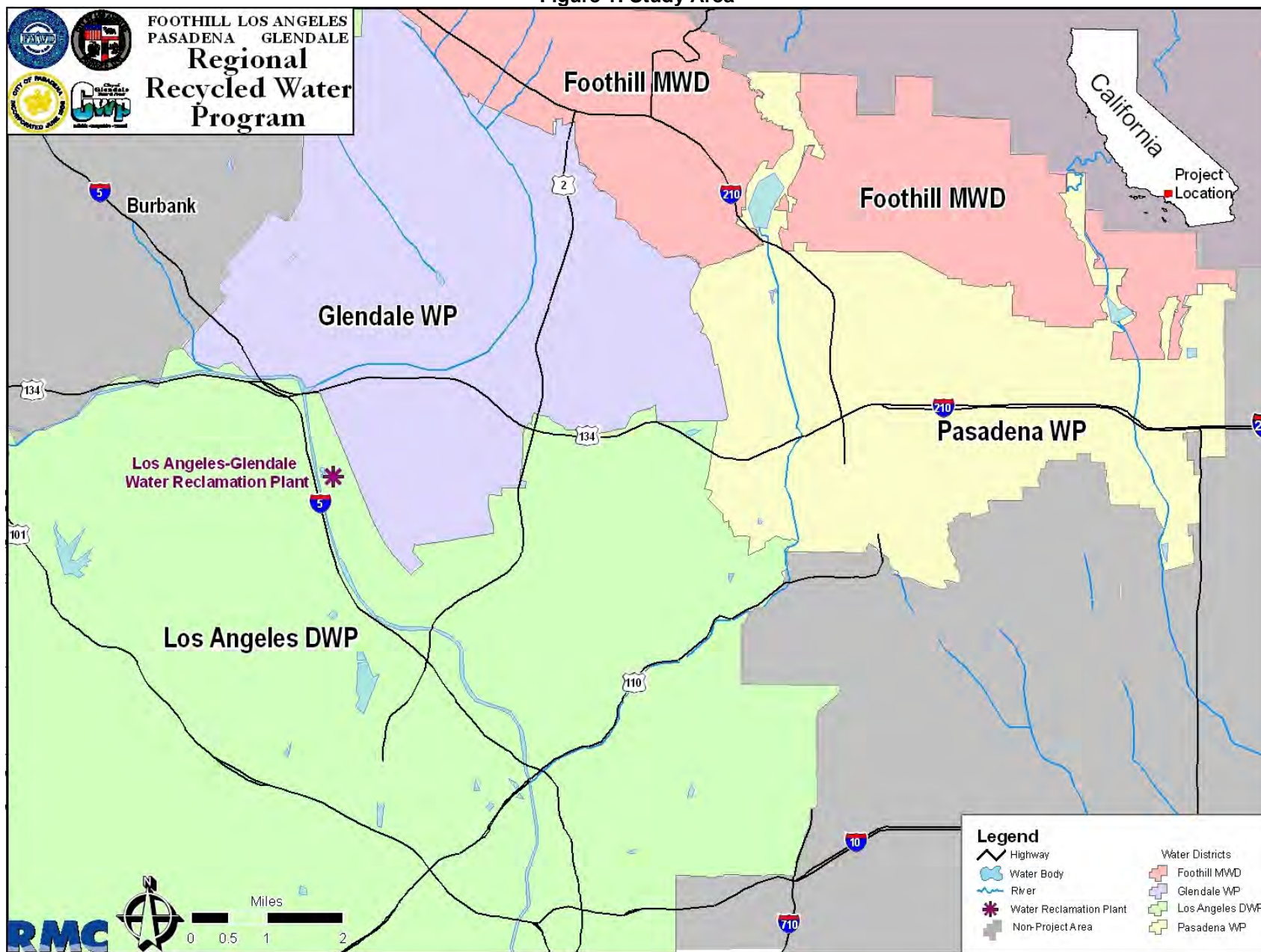

LAGWRP is a scalping plant that captures wastewater that would otherwise continue to flow the City of LADWP’s Hyperion Wastewater Treatment Plant (Hyperion). From this perspective, the plant provides hydraulic relief to the City of Los Angeles’ major sewers downstream. The LAGWRP service area generally covers the eastern San Fernando Valley, including Los Angeles, Glendale, Burbank and the Crescenta Valley. **Figure 2** and **Figure 3** present an LAGWRP treatment schematic and site plan, respectively.

## 2.2 LAGWRP Capacity

LAGWRP has a tertiary treatment capacity of 20 million gallons per day (MGD) and **Table 1** summarizes projected LAGWRP effluent flows. All LAGWP effluent is used for non-potable demands or discharged to the Los Angeles River. Water destined for non-potable reuse is conveyed to a 2 million gallons (MG) storage tank across the LA River in Griffith Park. Treated effluent discharged to the LA River enters at the eastern bank, which is an unlined portion of the river approximately 5 miles upstream of LA Narrows. Sludge and backwash water from LAGWRP are discharged to Hyperion.

**Table 1: Projected LAGWRP Recycled Water Production**

Units	2010	2015	2020	2025
afy	18,320	19,230	20,190	21,200
MGD	16.4	17.2	18.0	18.9

Source: Glendale, 2005; Table V-1

Due to a pending nitrogen discharge limitation to the LA River (CH:CDM, 2006a), the conventional activated sludge process is currently being modified with installation of nitrogen/denitrification (NdeN) facilities to reduce nitrogen concentrations. Initial operations began on April 30 but full operations are not expected until 2008. Prior to installation there was concern that the NdeN process would reduce treatment capacity to 15 MGD, but reduced flows have not been observed to date (LADWP p.c., 2007b).

## 2.3 LAGWRP Planning

The LA Recycled Water Master Plan (RWMP) (CH:CDM, 2006a) and Integrated Resources Plan (IRP) (CH:CDM, 2006b) had two primary recommendations for LAGWRP:

1. Add 5 MG of recycled water operational storage with real time control by 2012 and 5 MG of wastewater operational storage with real time control by 2012
2. Maintain the option to upgrade LAGWRP to advanced treatment [microfiltration (MF), reverse osmosis (RO), and ultraviolet disinfection (UV)]

The potential upgrade to advanced treatment at current capacity is a “Go If Triggered” project. The project was considered because LAGWRP effluent will not be able to be discharged to the LA River without advanced treatment once expected future California Toxics Rule (CTR) requirements for metals are implemented (CH:CDM, 2006a). A possible alternative to installation of advanced treatment would be to transition LAGWRP to an on-demand operation, meaning it would be operated to match recycled water demands, leaving excess wastewater in the interceptor sewer flowing to Hyperion.



Figure 2: LAGWRP Treatment Schematic

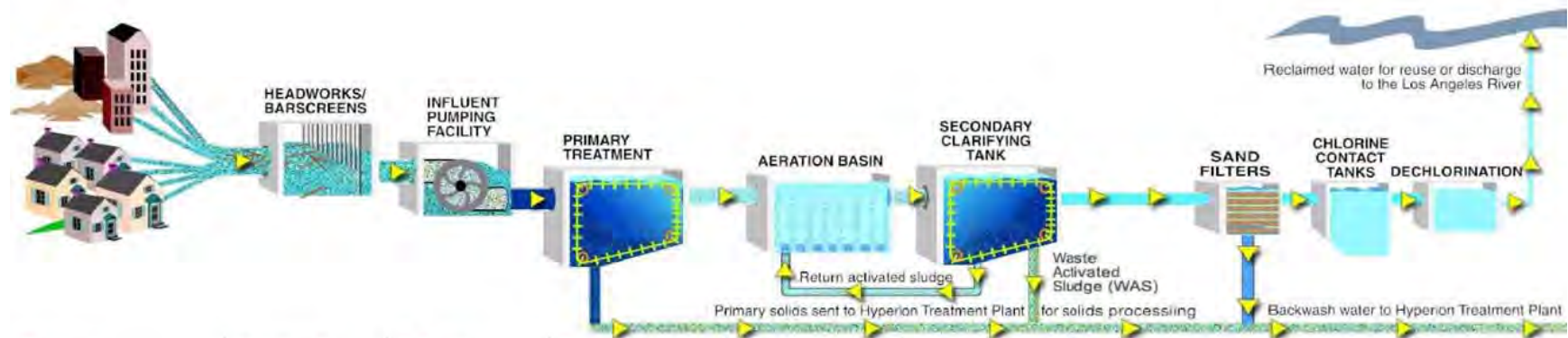

**Sewers**

The North Outfall Sewer carries wastewater to LAG for treatment from commercial and residential sources in the eastern portion of the San Fernando Valley . About 96% of the 20 million gallon per day flow comes from commercial and residential uses and only about 5% from industrial uses .

**Headworks**

At the Headworks, bars and screens remove the largest solids – such as branches, plastics, and rags. Grit, which is sand, rocks and small debris, is also removed. Screening, along with grit removal, is called preliminary treatment.

**Influent Pumping Facility**

The influent add additional energy to the wastewater, so that it will flow through the Plant's treatment processes without the need for further pumping.

**Primary treatment**

Most of the solids (sludge) are removed here after they settle to the bottom of the covered primary tanks. All of the primary sludge flows back into the main sewer system where it is sent to the Hyperion Treatment Plant for further processing. The remaining wastewater then flows by gravity to the secondary treatment system for further treatment. The primary tanks are covered to reduce odors.

**Secondary Treatment – Aeration Tanks**

Bacteria are added to the aeration tanks for the nitrification-denitrification process. The bacteria feed off the organic wastes in the wastewater. Oxygen is added in the nitrification process to speed up the bacteria's rate of decomposition. The nitrification-denitrification process reduces the amount of nitrogen in the plant's effluent. The wastewater, rich in activated sludge, then flows to the secondary clarifiers.

**Secondary Treatment – Final Settling Tanks**

The second stage of secondary treatment involves the settling of activated sludge by gravity in the final settling tanks, or secondary clarifiers. A portion of this settled activated sludge is returned to the aeration tanks (returned activated sludge, or RAS) to maintain biological equilibrium in the aeration tank, while the remaining portion is discharged/ wasted (waste activated sludge, or WAS) to the sewer. All of the waste activated sludge flows to the Hyperion Treatment Plant for further processing.

**Tertiary Treatment**

After secondary treatment, the wastewater flows through dual-bed or tetra denite sand filters to remove any remaining solids. To improve filtering, ALUM is used as a coagulant to increase the size of the remaining solids.

**Disinfection**

Disinfection is a two-step process. Liquid bleach (sodium hypochlorite) is added to the wastewater which kills any remaining pathogens or disease-carrying organisms. The chlorine-containing water remains in the last set of holding tanks at the plant for about two hours. The water is then dechlorinated (with sodium bisulfite) to protect fish and other aquatic wildlife. The treated water is then reclaimed or discharged to the LA River.

**Water Reclamation**

Of the 20 million gallons processed each day at LAG, about 4.5 million gallons are used for reclaimed purposes by DWP and the City of Glendale . Some is utilized at the plant for treatment processes and landscape irrigation. About 600,000 gallons per day is used as cooling water by the Glendale Steam Power Plant. Other uses include irrigation at Griffith Park , in freeway landscaping, local cemeteries and at nearby golf courses. The remainder flows into the Los Angeles River where it supports the river's riparian habitat.

Source: [www.lasewers.org/treatment\\_plants/la\\_glendale/flowchart/flowchart.htm](http://www.lasewers.org/treatment_plants/la_glendale/flowchart/flowchart.htm)

Figure 3: LAGWRP Site Plan / Facilities



Source: CH:CDM, 2006b; Figure 2-8

### 3 Non-Potable Recycled Water Demands

As illustrated in **Table 2** and **Figure 4**, existing LADWP and GWP recycled water demand uses less than 25% of available recycled water from LAGWRP. Also evident in the table is the seasonal nature of the existing demands with increased summer use due to peak season demand from landscape irrigation.

**Table 2: Existing Use of LAGWRP Recycled Water and Remaining Allotment by Agency (af)**

Agency	J	F	M	A	M	J	J	A	S	O	N	D	Total
<b>Existing Use</b>													
LADWP	44	74	118	162	192	207	221	207	192	162	118	74	1,770
GWP	101	106	153	158	218	271	276	274	216	134	106	108	2,120
PWP	-	-	-	-	-	-	-	-	-	-	-	-	-
<b>Subtotal</b>	<b>145</b>	<b>179</b>	<b>271</b>	<b>321</b>	<b>410</b>	<b>478</b>	<b>497</b>	<b>480</b>	<b>408</b>	<b>297</b>	<b>224</b>	<b>182</b>	<b>3,890</b>
<b>Remaining Allotment</b>													
LADWP	702	664	608	548	508	468	490	519	528	569	617	654	6,876
GWP	189	185	180	174	112	3	17	23	77	107	137	134	1,338
PWP	448	443	436	426	420	405	427	435	432	439	441	437	5,188
<b>Subtotal</b>	<b>1,339</b>	<b>1,292</b>	<b>1,224</b>	<b>1,149</b>	<b>1,039</b>	<b>876</b>	<b>935</b>	<b>977</b>	<b>1,037</b>	<b>1,114</b>	<b>1,195</b>	<b>1,225</b>	<b>13,402</b>
<b>Total</b>	<b>1,493</b>	<b>1,476</b>	<b>1,452</b>	<b>1,421</b>	<b>1,399</b>	<b>1,349</b>	<b>1,423</b>	<b>1,451</b>	<b>1,439</b>	<b>1,462</b>	<b>1,470</b>	<b>1,456</b>	<b>17,292</b>

Note: Monthly effluent flows based on 2000 - 2007 LAGWRP flow records. Average annual influent flow was 17.0 MGD and average annual effluent flow was 15.4 MGD. Monthly recycled water demands based on each agency's monthly and annual demand estimates.

**Figure 4: LAGWRP Existing Supply and Demand Curve**

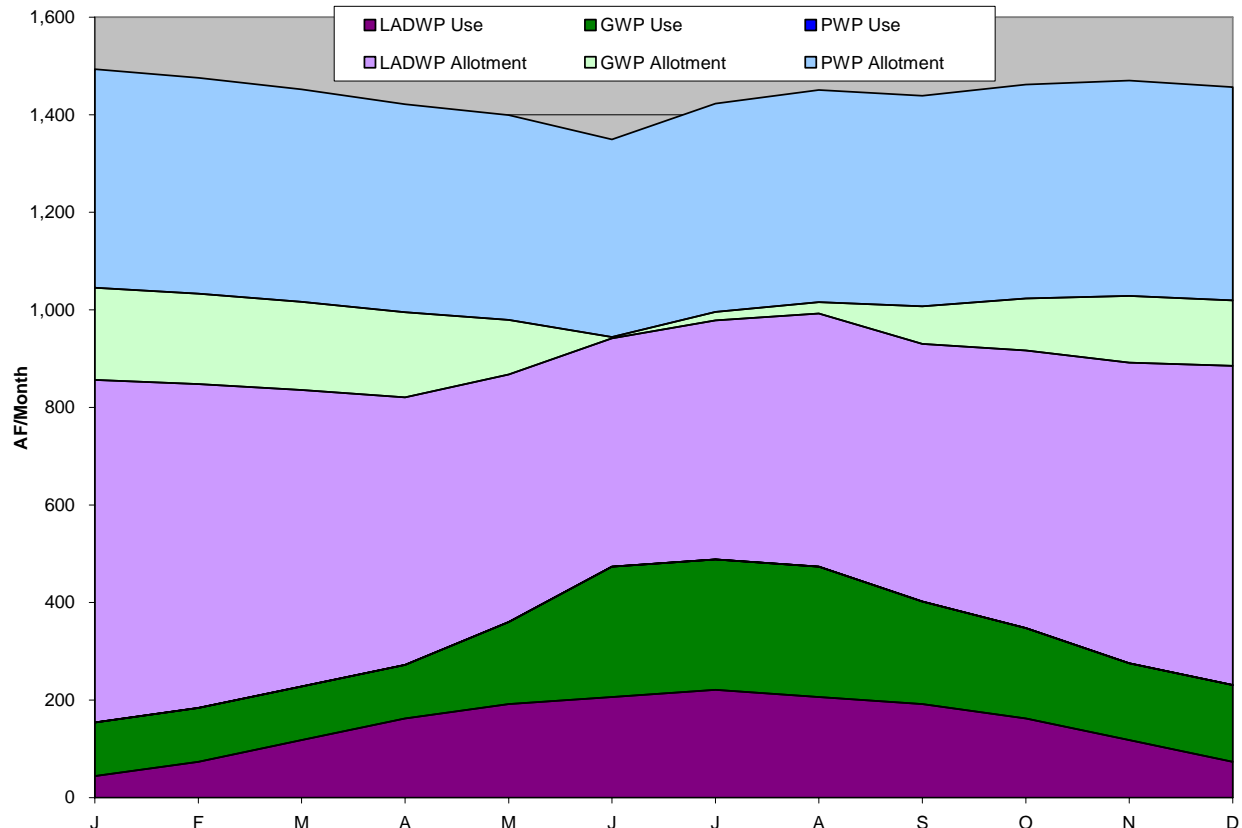

### 3.1 Glendale Water and Power

As summarized in **Table 3**, recycled water from LAGWRP currently serves over 40 GWP customers with a total demand ranging from 1,790 to 2,440 afy [GWP, 2006; GWP personal communication (p.c.), 2007a]. **Figure 5** presents the existing GWP recycled water infrastructure.

**Table 3: GWP Existing Recycled Water Projects**

Project	Primary Customers	Average Annual Demand
Power Plant	<ul style="list-style-type: none"> <li>Glendale Grayson Power Plant</li> <li>Caltrans – I-5 &amp; Fwy 134</li> </ul>	440 – 660 afy
Forest Lawn	<ul style="list-style-type: none"> <li>Forest Lawn Memorial Park</li> <li>Street Medians (Brand Blvd &amp; Garfield Ave)</li> <li>Cerritos Elementary School</li> <li>Edison Elementary School &amp; Pacific Park</li> </ul>	230 – 430 afy
Verdugo Canyon & Scholl Canyon (Verdugo-Scholl)	<ul style="list-style-type: none"> <li>Oakmont Country Club</li> <li>Scholl Canyon Golf Course and Landfill</li> <li>Caltrans – Fwy 2 &amp; 134</li> <li>Glendale Community College (dual-plumbing)</li> <li>Various Parks and Recreations Sites</li> <li>Multiple Schools</li> </ul>	980 – 1,200 afy
Brand Park	<ul style="list-style-type: none"> <li>Brand Park and Pelanconi Park</li> <li>Grandview Memorial Park</li> <li>Glenoaks Blvd Median</li> <li>Disney Animation Complex (dual-plumbing)</li> </ul>	145 – 155 afy
<b>Total</b>		<b>1,790 – 2,440 afy</b>

Sources: GWP, 2005 - Section V.C & Figure 22; GWP p.c., 2007.

Glendale's recycled water use goal is to meet 10 percent of total demands, which is approximately 3,500 afy (GWP, 2006). In the 1990's, GWP began to require all new office buildings within the Glendale city limits to install dual-plumbing. Glendale has estimated a conservative recycled water demand of 100 afy for landscape irrigation and toilet flushing (via dual-plumbing) in the downtown area (GWP, 2006; Table 8). **Table 4** and **Figure 6** summarize potential GWP recycled water demands.

**Table 4: GWP Potential Recycled Water Projects**

Project	Primary Customers	Average Annual Demand
Forest Lawn	<ul style="list-style-type: none"> <li>S. Central Avenue</li> <li>Downtown Buildings (dual plumbing)</li> <li>Glendale Town Center</li> </ul>	5+ afy
Verdugo Canyon & Scholl Canyon (Verdugo-Scholl)	<ul style="list-style-type: none"> <li>Various Housing Developments</li> <li>Downtown Buildings (dual plumbing)</li> <li>Various Parks and Recreation Sites</li> </ul>	270+ afy
Brand Park	<ul style="list-style-type: none"> <li>Various Schools</li> <li>Disney Campus (dual plumbing)</li> <li>Caltrans – Fwy 134 &amp; I-5</li> <li>San Fernando Road Landscape Irrigation</li> </ul>	165+ afy
<b>Total</b>		<b>440+ afy</b>

Source: GWP, 2005 - Figure 23; GWP p.c., 2007.

Note: Demand estimates have not yet been developed for all customers.

Figure 5: Existing GWP Recycled Water Infrastructure

**CITY OF GLENDALE  
 WATER DEPARTMENT**  
**RECYCLED WATER  
 PROGRAM PIPELINES**

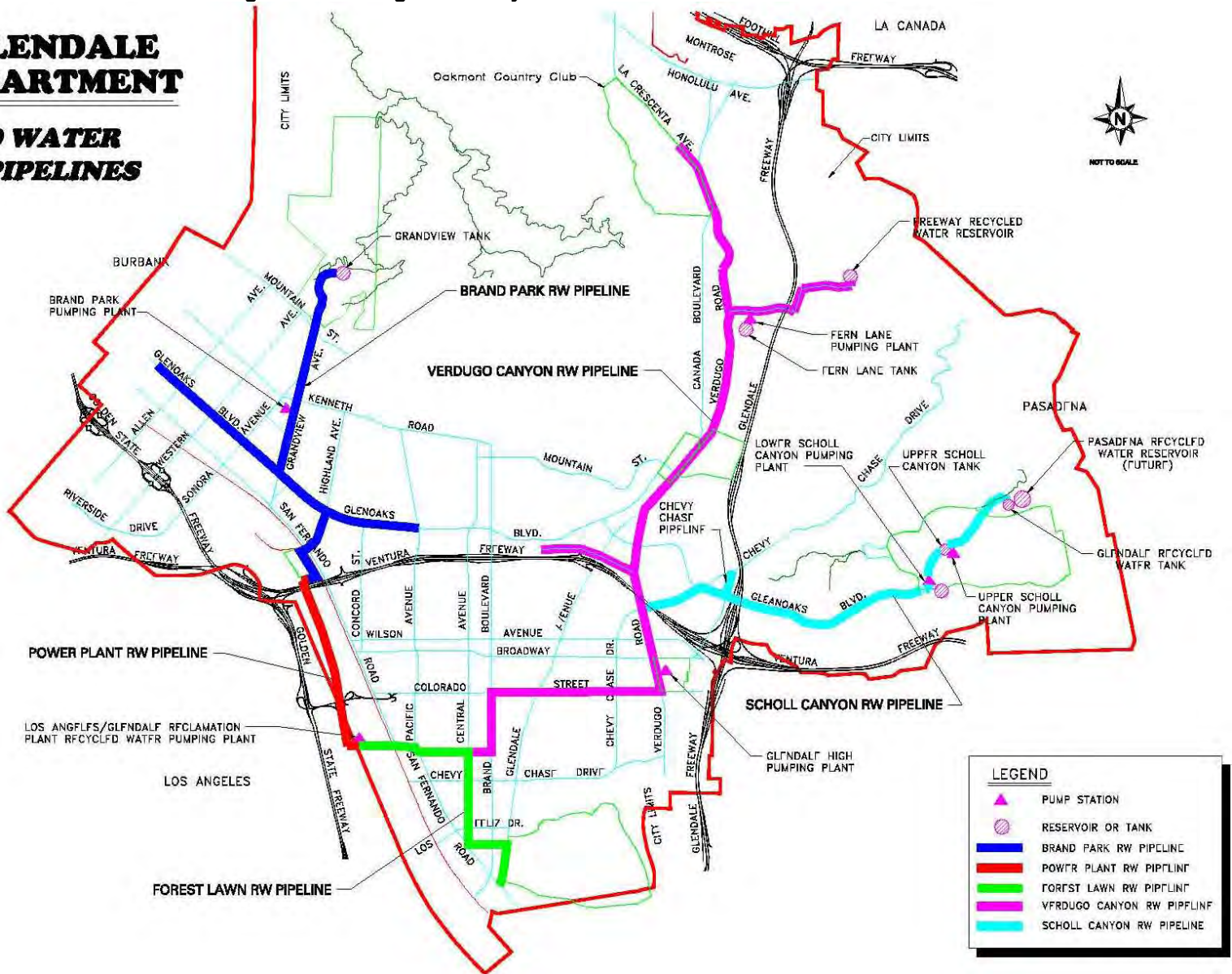

Source: GWP, 2005; Figure 21

Figure 6: Potential GWP Recycled Water Customers

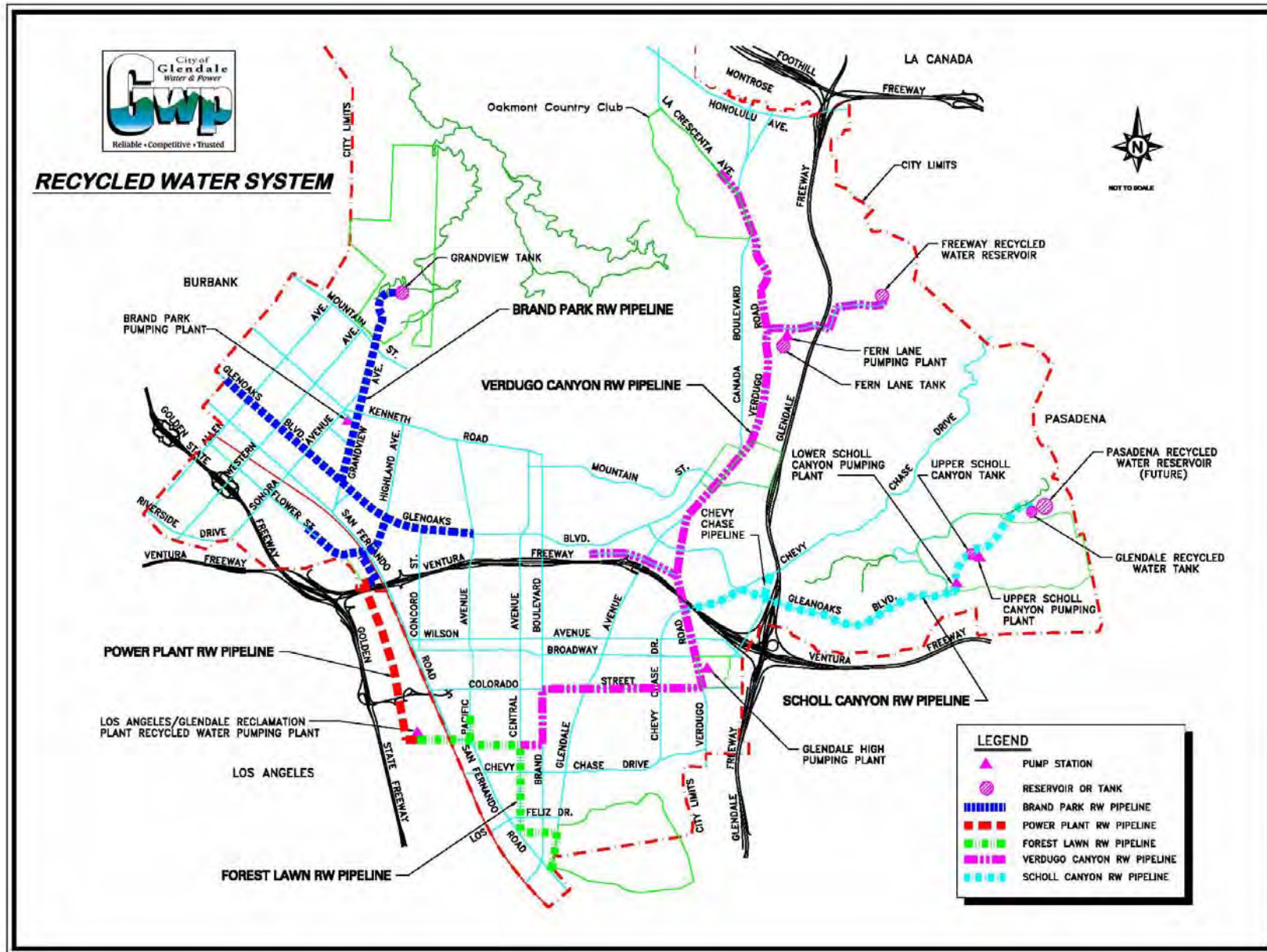

Source: GWP p.c., 2007

GWP has recommended construction of the “Glendale Tee” project, which will supply recycled water for irrigation and dual-plumbing demands in the downtown area as well as connect two distribution systems (Verdugo Canyon and Brand Park). The proposed customers served by the project would be a combination of users in Table 4 from the Verdugo-Scholl and Forest Lawn projects along the Central Avenue and Brand Boulevard corridor. The project’s projected demand is 450 afy and is the most likely GWP project in Phase 1 of the CeLAC RWRP (GWP p.c., 2007a).

Future phases after the Glendale Tee project are dependent upon the timing of completion of planned residential and commercial development. High demand customers would be connected once development is completed and smaller demand customers along the alignment would be served as well. Also, the next set of GWP projects will likely include an operational storage tank in the Lower Scholl Canyon area (GWP p.c., 2007).

### 3.2 Los Angeles Department of Water and Power

As summarized in **Table 5**, LADWP currently uses over 1,700 afy of recycled water from LAGWRP (CH:CDM, 2006a).

**Table 5: LADWP Existing Recycled Water Use from LAGWRP**

Project	Customers	Average Volume
Griffith Park	<ul style="list-style-type: none"> <li>Wilson and Harding Golf Courses</li> <li>Some parkland</li> <li>Caltrans (I-5)</li> </ul>	1,770 af
Los Angeles Greenbelt Project	<ul style="list-style-type: none"> <li>Forest Lawn Memorial Park – Hollywood Hills</li> <li>Mt. Sinai Memorial Park</li> <li>Lakeside Golf Course</li> <li>NBC-Universal</li> </ul>	

Source: CH:CDM, 2006a

The LA RWMP and IRP recommended two tiers of recycled water expansion. The largest customer identified was City of Los Angeles Department of Recreation and Parks with a demand of over 1,500 afy. The tiers are summarized in **Table 6** and **Figure 7**.

**Table 6: LADWP Recycled Water Master Plan – Central City Tiers**

Tier	# of Customers	Average Demand	Capital Cost	O&M	Estimated Cost
1	Over 50 customers	2,800 afy	\$64.5M	\$500K/yr	\$1,670/af
2	Over 100 customers, including Tier 1	5,400 afy	\$97.2M	\$1.5M	\$1,450/af

Source: CH :CDM, 2006a

Note: Estimated cost excludes treatment.

LADWP has identified over 2,000 afy of new projects within Tier 1 that are likely to be completed in the next five years. These projects are presented in **Table 7** and are likely projects for Phase 1 of the CeLAC RWRP.

Figure 7: LA RWMP Tier 1 and Tier 2 Facilities and Demands from LAGWRP

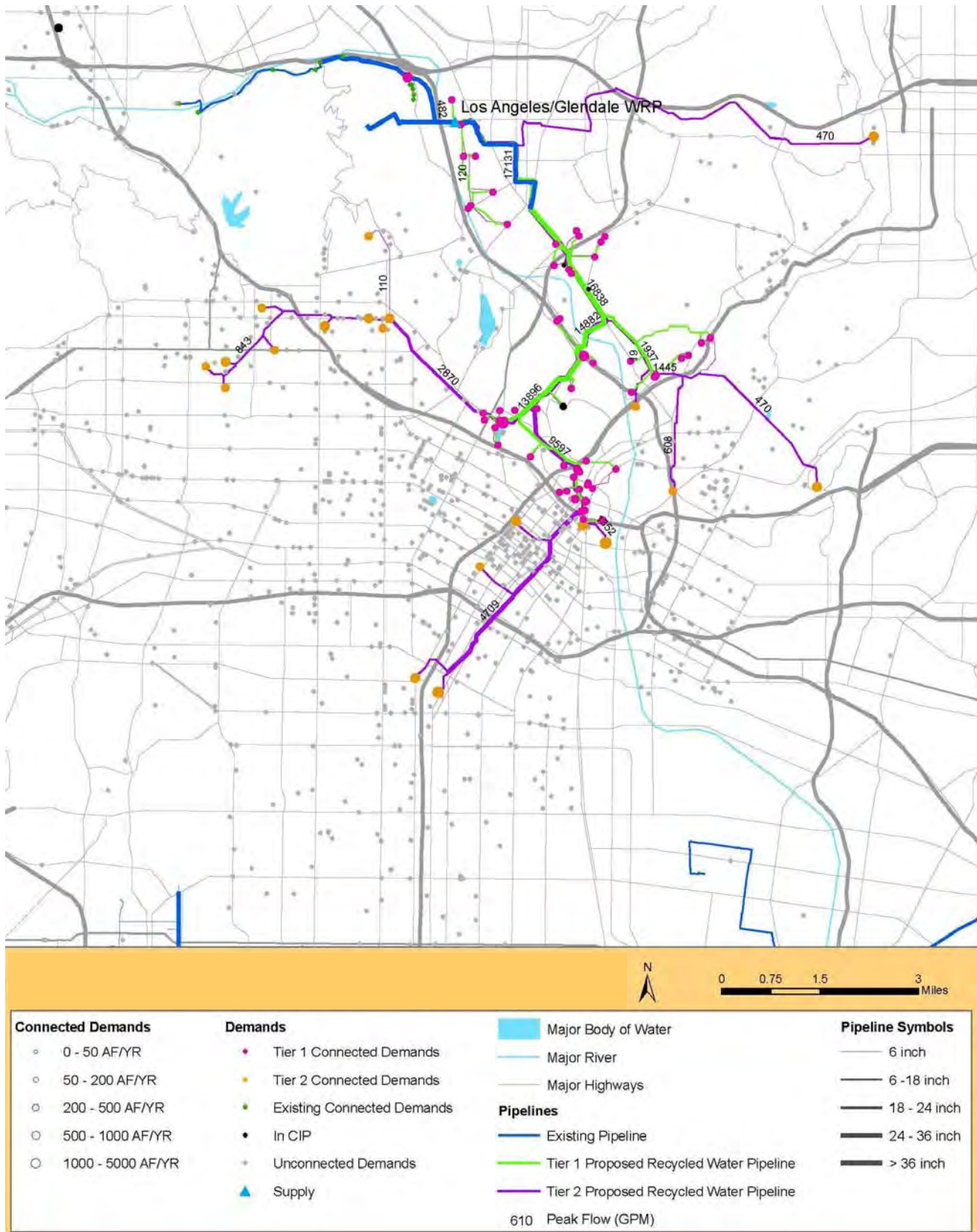

Source: CH:CDM, 2006b; Figure 6-5



**Table 7: LADWP Potential Recycled Water Projects for CeLAC RWRP Phase 1**

Project	Customer	Average Annual Demand
Los Angeles Zoo	<ul style="list-style-type: none"> <li>Los Angeles Zoo</li> </ul>	700 afy
Elysian Park	<ul style="list-style-type: none"> <li>Elysian Park</li> <li>Taylor Yard Park (150 afy)</li> </ul>	550 afy
NBC-Universal	<ul style="list-style-type: none"> <li>NBC-Universal Backlot Development (irrigation and dual plumbing)</li> </ul>	430 afy
Other	<ul style="list-style-type: none"> <li>Roosevelt Golf Course</li> <li>Future Forest Lawn Hollywood Hills Expansion</li> </ul>	540 afy
<b>Total</b>		<b>2,220 afy</b>

Sources: CH-CDM, 2006a; LADWP p.c., 2007a

### 3.3 Pasadena Water and Power

The PWP Recycled Water Feasibility Study (RWFS) was completed in May 2005 (MWH). The report evaluated three alternatives, which are summarized in **Table 8**. Alternative A and Alternative B are presented in **Figure 8** and **Figure 9**, respectively.

**Table 8: Pasadena Recycled Water Alternative Projects**

Project	Customers	Average Demand	Estimated Unit Cost <sup>1</sup>
Alternative A	<ul style="list-style-type: none"> <li>Brookside Golf Course</li> <li>Rose Bowl Stadium</li> <li>Brookside Park</li> <li>Defender's Park</li> </ul>	730 afy	\$990 - \$1,160/af <sup>2</sup>
Alternative B	<ul style="list-style-type: none"> <li>Over 30 customers, including Alternative A</li> </ul>	2,015 afy	\$1,330 - \$1,760/af
Alternative C	<ul style="list-style-type: none"> <li>Over 50 customers, including Alternative B</li> </ul>	3,395 afy <sup>3</sup>	\$2,660/af

Source: MWH, 2005; Section 4

Note:

- Unit costs are from source escalated from 2003 dollars to June 2007 dollars based on LA construction cost index (CCI) (17.4%).
- Source: PWP, p.c. 2007b.
- Includes supplemental water supplies in addition to recycled water, which are listed as part of the "Optional Isolated Systems" projects.

The Pasadena RWFS recommended Alternative B based on net present value (NPV) of \$540/af compared with an NPV of \$600/af for Alternative A. The primary benefit was the avoided cost of imported water purchase (MWD Tier 2 rate) plus \$250/af from the Metropolitan Water District of Southern California's (MWD) Local Resources Program (to be discussed further in Section 5.4). However, no further action has been taken by PWP based on the Alternative B's approximate unit cost \$1,500/af (\$1,330/af - \$1,760/af) even once the cost is reduced by a 25 percent matching grant (to approximately \$1,125/af) from United States Bureau of Reclamation (USBR) Title XVI. Consequently, this TM evaluated system components identified in the report that would build upon Alternative A in the most cost effective manner and investigated groundwater recharge with recycled water (GWR-RW) opportunities to reduce unit costs (see Section 4).

Figure 8: PWP Alternative A

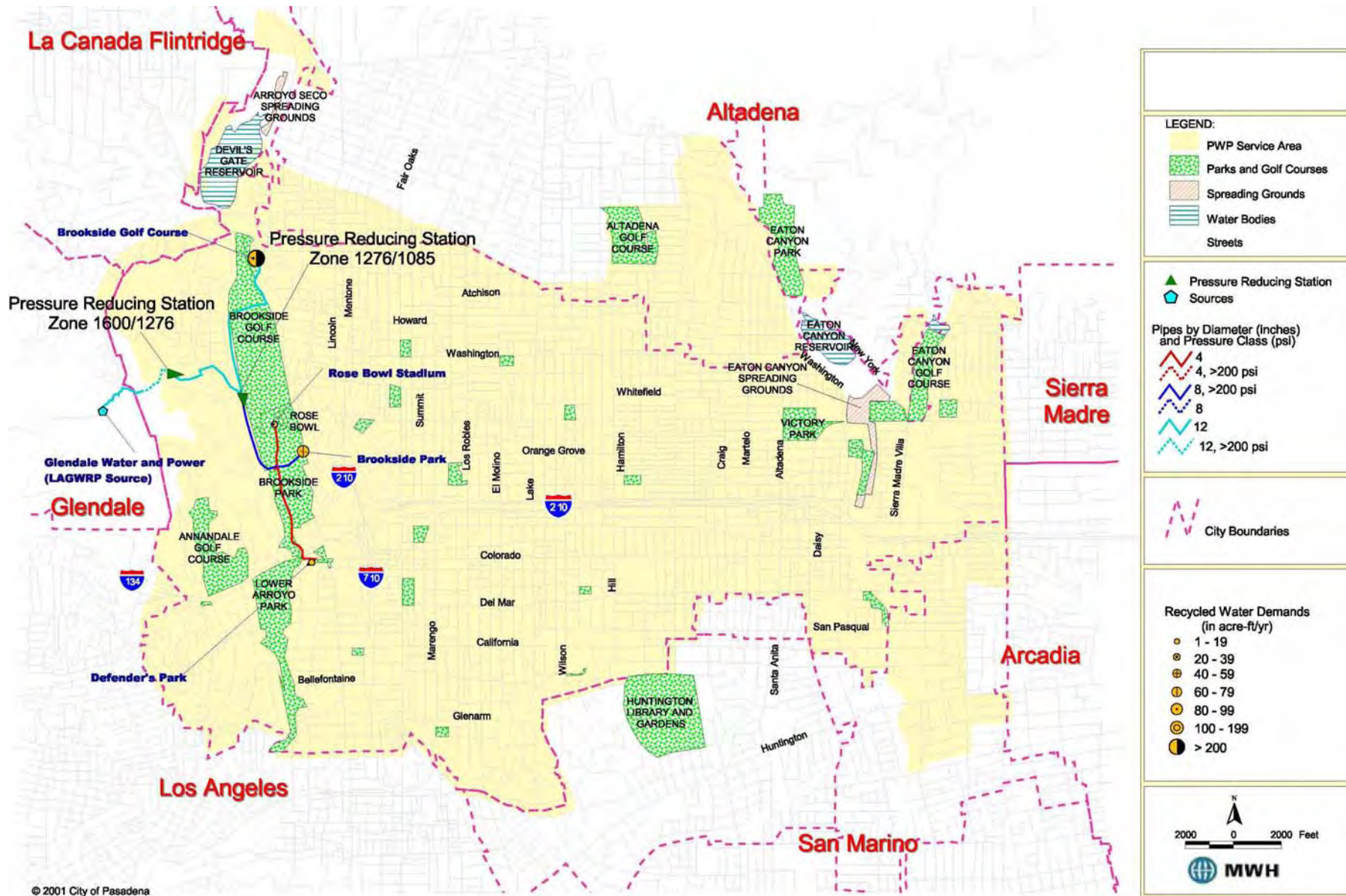

© 2001 City of Pasadena  
 Source: MWH, 2005; Figure 4-4

Figure 9: PWP Alternative B



To evaluate system segments (**Figure 10**), each segments' attributes are listed in **Table 9** and then **Table 10** lists the unit costs of segments with all prerequisites for conveyance from Segment 1 (which is Alternative A).

**Table 9: Incremental Unit Costs for System Segments**

Segment #	Segment Demand	Prerequisite Segment(s)	Incremental Amortized Cost <sup>1</sup>	Incremental Unit Cost (\$/af)	Total Incremental Unit Cost <sup>2</sup> (\$/af)
1	731 af		\$213,500	\$290	\$700
2	430 af	1	\$202,700	\$470	\$880
3	269 af	1	\$202,700	\$480	\$890
4	33 af	1	\$130,100	\$1,410	\$1,820
5A	69 af	1 & 4	\$46,300	\$360	\$770
5B	171 af	1 & 3	\$25,000	\$880	\$1,290
6	358 af	1 & 5	\$151,200	\$1,120	\$1,530
7	800 af	1, 2 & 6	\$400,100	\$170	\$580
8	202 af	1 & 2	\$135,900	\$440	\$850
9	199 af	1	\$89,600	\$750	\$1,160
10	99 af	1 & 9	\$149,000	\$680	\$1,090

Source: Pasadena RWMP; manipulation of Tables 4-4 and 4-5

Notes:

- Unit costs are from source escalated from 2003 dollars to June 2007 dollars based on LA CCI (17.4%). Amortized at 4 percent over 50 years (A/P factor = 0.047).
- Assumes \$410/af for user connections, engineering and administration fees, and O&M costs.

**Table 10: Incremental Unit Costs for System Segments from Segment 1 – Sorted by Cost**

Segment(s) #	afy	Description	Unit Cost (\$/af)	Comment
4+5A <sup>1</sup>	210	Arroyo Seco Area <sup>1</sup>	\$860	Possible next step after Alternative A
2+8	630	Huntington + Laterals	\$870	Possible next step after Alternative A
2	430	Huntington Library and Gardens	\$880	Possible next step after Alternative A
2+6+7	1,590	Service to City of Arcadia	\$880	Arcadia demand must be confirmed
3	270	Mountain View Cemetery	\$890	Possible next step after Alternative A
9+10	300	210/134 & Washington Blvd Spurs	\$1,140	Not likely - at this time - due to cost
9	200	210 & 134 Area Spurs	\$1,160	Not likely - at this time - due to cost
2+6	790	East Pasadena Extension	\$1,530	Only works with GWR at Eaton Wash
4	30	Hahamongna Watershed Park	\$1,820	Only works with Segment 5A

Source: Pasadena RWMP; manipulation of Tables 4-4 and 4-5

Note:

- Includes delivery of 110 afy to Valley Water Company (VWC) customers, as described in the Section 2.5.

Figure 10: PWP Recycled Water System Segments

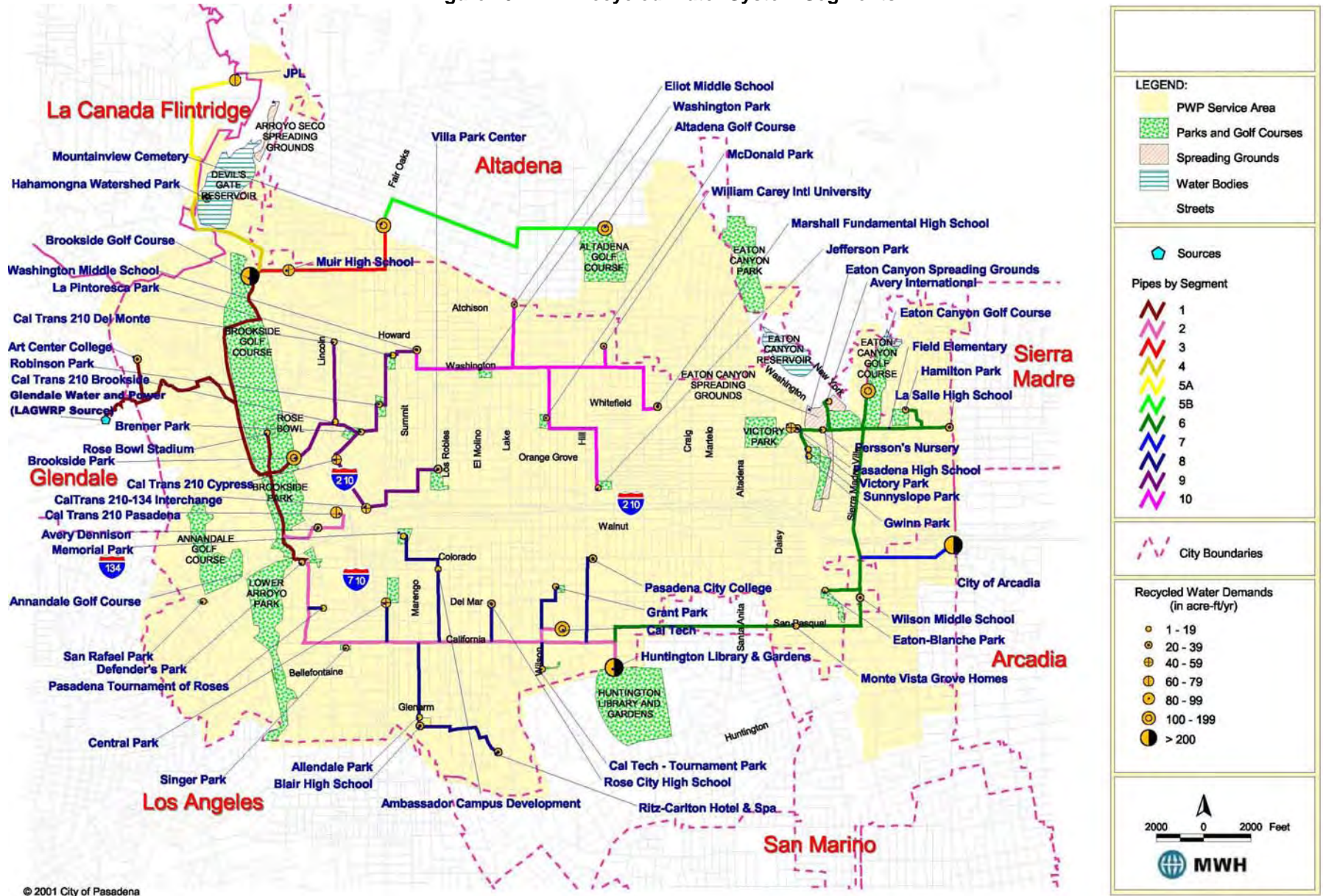

© 2001 City of Pasadena  
 Source: MWH, 2005

Based on the incremental costs in Table 10, three sets of segments appear most cost effective:

1. Segments 4 and 5A with Valley Water Company (VWC) non-potable demands (see next section) in the Devil’s Gate Reservoir area
2. Segments 2 and 8 to serve Huntington Library with laterals along the route
3. Segment 3 to serve Mountain View Cemetery

Some of these segments could be enhanced with the addition of GWR-RW, which is evaluated in Section 4.

### 3.4 Foothill Municipal Water District

Foothill Municipal Water District (FMWD) wholesales imported water from MWD to eight member agencies. Of these, non-potable demands for three agencies were reviewed in the area’s recycled water study by CVWD: 1) CVWD; 2) Valley Water Company (VWC); and 3) La Canada Irrigation District (LCID). **Table 11** summarizes the two project alternatives from the study and **Figure 11** presents the Enlarged Market Alternative.

**Table 11: Foothill Recycled Water Proposed Projects**

Alternatives	Customers	Average Demand (afy)	Estimated Unit Cost <sup>1</sup>
Caltrans Market Alternative	<ul style="list-style-type: none"> <li>• 5 CVWD Caltrans meters</li> <li>• 6 VWC Caltrans meters</li> <li>• 3 LCID Caltrans meters</li> </ul>	156	\$2,920/af
Enlarged Market Alternative	<ul style="list-style-type: none"> <li>• Caltrans Market Alternative</li> <li>• Demand in vicinity of Foothill Blvd</li> </ul>	310	\$2,010/af

Source: BE, 2004

Note:

1. Unit costs are from source escalated from 2004 dollars to June 2007 dollars based on LA CCI (12.9%).

Neither recycled water alternative was recommended for further investigation due to high costs. However, some potential high recycled water demand users on the southeastern portion of the proposed system could be combined with potential PWP users by the Devil’s Gate Reservoir. Three sites (#7, #8, and #9 on Figure 11) combine for over 100 afy of non-potable demands and are in the vicinity of the proposed PWP pipe by the Arroyo Seco Spreading Grounds (Segment 5A on Figure 10). All sites are currently served by VWC.

Figure 11: FMWD Potential Recycled Water Demands

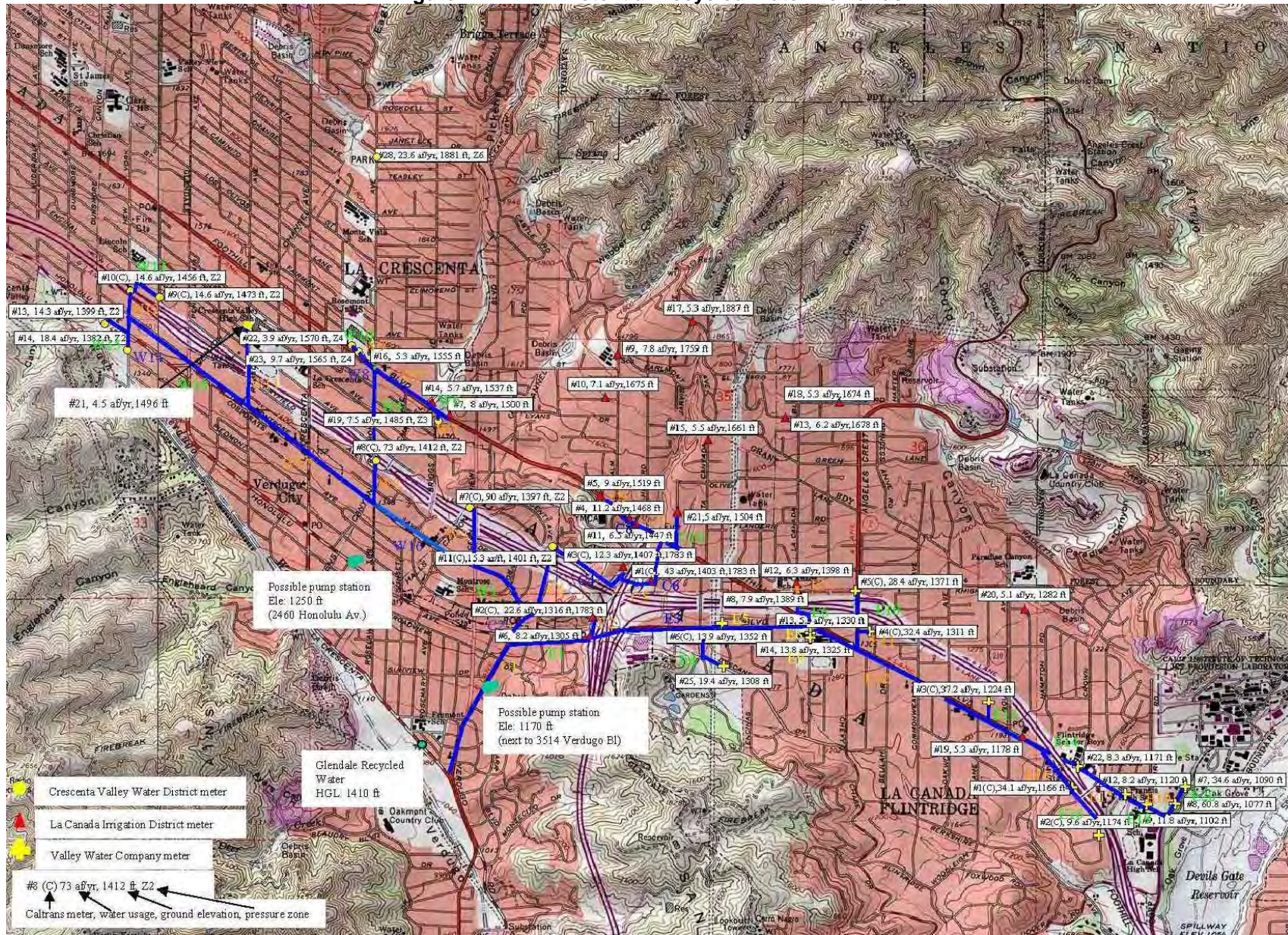

Source: BE, 2004; Figure 2

## 4 Groundwater Recharge with Recycled Water Assessment

This section provides background information and assumptions for GWR-RW and evaluates GWR-RW opportunities in the study area.

### 4.1 Background

GWR-RW provides opportunities for increased beneficial use of recycled water. The majority of non-potable demands considered in the previous section were for landscape irrigation, which has higher demand in the summer than in the winter. As a result, there is low demand for recycled water in the winter and GWR-RW provides a good option for cost-effective beneficial use of this recycled water during this period.

GWR-RW was assessed in two groundwater basins: 1) Raymond Basin; and 2) Verdugo Basin. The Raymond Basin lies under PWP (as well as other entities in the Raymond Basin Management Group<sup>3</sup>) and the Verdugo Basin lies under CVWD. The potential for implementation of GWR-RW within these groundwater basins are discussed in Section 4.2 and Section 4.3, respectively.

#### 4.1.1 GWR-RW Methods

GWR-RW can occur either by surface spreading or direct injection. The latter method has stricter treatment and extraction regulations. For example, surface spreading requires a minimum distance of 500 feet (ft) between the point of recharge and the nearest potable water well while direct injection requires a minimum distance of 2,000 ft. This requirement limits the locations of direct injection in developed areas with extensive networks of potable water wells, such as in Pasadena. Similarly, recycled water recharge cannot be combined with aquifer storage and recovery (ASR) projects since ASR project by definition use the same well for injection and extraction. In addition, direct injection of recycled water would not benefit from soil aquifer treatment (SAT), which can be effective at reducing concentrations of certain constituents, such as total organic carbon (TOC) and nitrate.

For evaluation in this TM, only surface spreading was considered due to multiple factors: 1) spreading sites already exist; 2) avoided cost of injection wells; 3) 500 ft minimum distance to potable wells compared with 2,000 ft minimum; and 4) water quality benefits of SAT.

#### 4.1.2 GWR-RW Regulations

All GWR projects must address Regional Water Quality Control Board (RWQCB) requirements, particularly the applicable Basin Plan objectives as well as RWQCB non-degradation objectives. Typical key RWQCB water quality constituents of concern include total dissolved solids (TDS), nitrate, and disinfection byproducts (DBPs). California Department of Public Health (CDPH) draft GWR-RW regulations must be addressed once recycled water is added to a GWR project. Key constituents of concern for CDPH are pathogens, trace organics and total nitrogen.

Although current draft CDPH regulations do not require advanced treatment of recycled water prior to GWR-RW via surface spreading, significant blending requirements (with water of non-wastewater origin, typically imported MWD supply) can severely limit the operation and size of the project. Also, various agencies throughout California have experienced both regulatory and general public concerns with potential emerging contaminants that potentially could be in the recycled water and not removed in the SAT process. Accordingly, it is assumed that a GWR-RW component in this project concept would undergo advanced treatment (MF/RO/UV) at LAGWRP to satisfy both regulatory requirements and

---

<sup>3</sup> The Raymond Basin Management Board (RBMB) serves as the Watermaster for the Raymond Basin. The RBMB oversees implementation of the basin's adjudication and approves plans for storage of in the basin.



public perception. The addition of NdeN process at LAGWRP should lower nitrate and nitrogen to satisfactory levels. RO and UV should address salinity and trace organics issues. .

### 4.1.3 Blend Water

CDPH draft GWR regulations include a formula for determining the maximum recycled water concentration (RWC) in the recharge water. With advanced treatment, the initial minimum blend ratio is 1:1 (RWC = 50%), meaning one part advanced treated recycled water to one part blend water.

Blend water for recycled water can be provided from potable or non-potable supplies. This TM focused on: 1) stormwater; 2) raw imported water; and 3) treated imported water. Of these, stormwater is preferred since there is no purchase cost and likely has low TDS concentrations. A drawback of stormwater is the limited periods of the year it is available and high flows when it is available. However, this has mostly been addressed by flood control infrastructure already constructed in the study area. Treated imported water would be the least preferred blend supply due to its high purchase price and water quality concerns from DBPs and TDS. Raw imported water would be preferred over treated imported water due to its slightly lower purchase price and lack of DBPs. However, raw imported water conveyance infrastructure is generally less extensive than treated imported water so availability would likely be an issue. This TM focuses on the use of stormwater as the primary blend supply.

### 4.1.4 Advanced Treatment Location

The addition of advanced treatment creates concentrate (brine) disposal and related operational issues that must be addressed. Advanced treatment facilities could be located either at LAGWRP or at the recharge site(s). Advanced treatment facilities at LAGWRP would allow for simple disposal of concentrate to Hyperion via the existing infrastructure and would be a convenient location to take advantage of existing WRP operations personnel, but would require that advanced treatment of all recycled water flows (including those destined to serve non-potable uses) during recharge periods due to the common distribution system. Remote siting of advanced treatment facilities would avoid advanced treatment of non-potable flows, but concentrate disposal via a new pipeline would likely be cost prohibitive (based on MWH, 2005; Appendix B) and siting a new treatment plant could be challenging.

Based on these considerations, for this project concept advanced treatment facilities would be at LAGWRP, and would be operated only during recharge periods.

## 4.2 Raymond Basin

A comprehensive recharge investigation has not been performed for the Raymond Basin, although a few studies were completed for specific areas within the basin. **Figure 12** presents spreading grounds within the Raymond Basin. Of the four sites, two spreading grounds are located in the vicinity of proposed PWP recycled water infrastructure: 1) Arroyo Seco Spreading Grounds (Monk Hill Sub-basin); and 2) Eaton Wash Spreading Grounds (Pasadena Sub-basin). The Arroyo Seco Spreading Grounds are located in the western part of the PWP service area and the Eaton Wash Spreading area is located in the northeast region. The sites are discussed further in Section 4.2.1 and 4.2.2, respectively.

Figure 12: Raymond Basin Recharge Facilities



Figure 13

The primary water quality objectives for the Raymond Basin are presented in **Table 12**. Key RWWQCB constituents of concern in the basin are TDS, nitrogen, sulfate, chloride, and boron.

**Table 12: Basin Plan Objectives for Groundwater in Raymond Basin**

Constituent	Water Quality Objective
Bacteria	< 1.1/100 mL
Chemical Constituent and Radioactivity	Concentrations less than those established in Title 22 of the California Code of Regulations (State MCLs).
Mineral Quality	TDS – 450 mg/L Sulfate – 100 mg/L Chloride – 100 mg/L Boron – 0.5 mg/L
Nitrogen (Nitrate & Nitrite)	10 mg/L nitrogen (as nitrate-nitrogen + nitrite-nitrogen) 45 mg/L as nitrate 10 mg/L as nitrate-nitrogen 1 mg/L as nitrite-nitrogen
Taste and Odor	Concentrations that do not cause nuisance or adversely affect beneficial use.

Source: LA RWQCB Basin Plan, 1994

For comparison, **Table 13** presents the primary water quality objectives for the Raymond Basin along with constituent concentrations for potential recharge supplies based on the *RBMB Draft Criteria for Delivery of Supplemental Water* (Stetson, 2006). Recycled water from LAGWRP without advanced treatment raises potential water quality issues; however, blend water quality would ultimately be compared to the basin water quality objectives. Recycled water with advanced treatment would likely meet all objectives and, in fact, could be considered a benefit to groundwater quality. As mentioned previously, surface water generally has satisfactory water quality for constituents of concern in groundwater. Raw imported water has elevated concentrations of each constituent but is within the basin objectives. Treated imported water would likely raise TDS and sulfate concerns but mitigation measures and/or blending could address these issues.

**Table 13: Water Quality of Groundwater and Potential Recharge Supplies**

Constituent	Ground-water Objectives	Tertiary Treatment	Advanced Treatment	Surface Water	Raw Imported Water	Treated Imported Water
<i>all values in mg/L</i>	Raymond Basin	LAGWRP	estimated	Arroyo Seco	State Water Project	Weymouth WTP
TDS	450	676	10	244	225	452 <sup>a</sup>
Nitrate (N)	10	2.8	0.2	0.3	3.6	2.4
Sulfate	100	137	2.8	36	34	164
Chloride	100	152	3.6	18.9	55	75
Boron	0.5	0.5	0.01	NA	0.16	0.15
Total Nitrogen	10	9 <sup>b</sup>	1.0	NA	NA	NA
TOC	NA	NA	0.7	NA	4.3	NA

Sources: MWH, 2005 & Stetson, 2006

NA Not available

Notes:

- a. MWD's Weymouth WTP treats imported water from the State water Project (SWP) and the Colorado River Aqueduct, which has a higher TDS than the SWP.
- b. Based on new NdeN process.

### 4.2.1 Arroyo Seco Spreading Grounds

PWP previously diverted their maximum Arroyo Seco diversion rights of 25 cubic feet per second (cfs) upstream of the Arroyo Seco Spreading Grounds for treatment of up to 5 mgd at the Behner Treatment Plant (BTP) and recharge of the remainder at the spreading grounds. The plant was shut down in 1993 due to increased water quality requirements and, since then, maximum diversions have occurred to the Arroyo Seco Spreading Grounds.

Operations at the spreading grounds were reevaluated recently as part of the Hahamongna Water Park Master Plan (Pasadena, 2003). One of the primary objectives of the master plan was to “maximize groundwater recharge to minimize the amount of water purchased from outside sources.” As a result, the plan recommended refurbishing 12 existing operating basins on the east side of the Devil’s Gate Reservoir, creating two new basins on east side, and creating three new basins on the west side (see **Figure 13**). Note that increased recharge could affect groundwater contamination remediation activities by the National Aeronautical and Space Administration (NASA) at the Jet Propulsion Laboratory (JPL) but NASA has expressed support for the Hahamongna Water Park Master Plan (PWP, p.c. 2007b).

**Table 14** summarizes the recharge characteristics of the existing and planned spreading grounds.

**Table 14: Characteristics of Arroyo Seco Spreading Grounds**

Item	Existing	Planned	New Western Basins
Total Area	24 ac	26 ac	6.3 ac
Wetted Area	13.1 ac	NA	NA
Number of Operating Basins	12	17 (5 new)	3 (all new)
Total Storage Capacity	30 af	NA	NA
Intake Capacity	75 cfs	NA	NA
Estimated Percolation Rate	18 cfs	25 cfs	25 cfs
Average Annual Recharge	3,500 af	NA	NA
Groundwater Credit	60%	60% - 80%	80%
Maximum Actual Annual Recharge	11,285 af (1995)	-	-
Maximum Potential Annual Recharge	17,520 af	25,000 af	6,000 af

Source: Hahamongna Water Park Master Plan (Pasadena, 2003); Geoscience, 2004

As shown in Figure 13, the CDPH minimum well distance of 500 ft would limit recharge at the Arroyo Seco Spreading Grounds to three new basins on the west side of Devil’s Gate Reservoir. This would limit the volume of recycled water that could be recharged to approximately 3,000 afy based on abiding the CDPH requirement of RWC not exceeding 50% of the 6,000 af maximum potential annual recharge in the new, western basins.

The Hahamongna Water Park Master Plan also mentioned plans by Los Angeles County Flood Control District (LACFCD) to pump water captured behind the Devil’s Gate Dam up to the recharge basins on the east and west side of the Devil’s Gate Reservoir. The volume of water to be pumped was not estimated in the plan but LACFCD recently submitted a project description for the Hahamongna Basin Multiuse Project to the LA Integrated Regional Water Management Plan (IRWMP) database that included estimated benefits of 2,000 afy of potable water supply from Arroyo Seco surface water diversions to BTP (after treatment upgrades) and 5,000 afy of water for groundwater recharge (LACFCD p.c., 2007).

Figure 13: Arroyo Seco Spreading Grounds and Wells



## 4.2.2 Eaton Wash Spreading Grounds

The Eaton Wash Spreading Grounds have not been investigated in as much detail as other potential Raymond Basin recharge sites and historically has been underutilized due to limited natural inflows. **Table 15** summarizes the site's characteristics and **Figure 14** presents an aerial photo of the site. One advantage of the Eaton Wash Spreading Grounds for GWR-RW, besides significant available recharge capacity, is the lack of potable wells near the site.

**Table 15: Characteristics of Eaton Wash Spreading Grounds**

Item	Existing	Potential Maximum
Total Area	28 ac	same as existing
Wetted Area	24 ac	same as existing
Total Number of Basins	14	same as existing
Total Storage Capacity	525 af	same as existing
Intake Capacity	200 cfs	NA
Estimated Percolation Rate	0.9 ft/day	2.0 ft/day
Annual Recharge	3,500 af	17,000 af
Groundwater Credit	80%	same as existing
Maximum Actual Annual Recharge	8,206 af (1995)	17,000 af

Source: Geoscience, 2004

To address the underuse of the spreading grounds, LACFCD previously produced a preliminary report (LACFCD, 1997) that recommended diverting water from the Devil's Gate Dam to Eaton Wash and Arroyo Seco Spreading Grounds. The report estimated up to 2,200 afy and 1,450 afy could be conveyed to the Eaton Wash and Arroyo Seco Spreading Grounds, respectively. The report proposed to convey stormwater from Devil's Gate Dam to Eaton Wash Dam (and on to Eaton Wash Spreading Grounds) via a pipeline for approximately 4.2 miles and then via open channel through approximately 2.3 miles of the Fair Oaks Drain. Use of the existing drain offers substantial cost savings.

Based on this report, there are potential opportunities to coordinate between PWP and LACFCD to maximize groundwater recharge in the area by sharing conveyance infrastructure and reducing overall costs. For example, PWP could construct Segment 3 (Mountain View Cemetery) of their recycled water system to Altadena Golf Course (as proposed in the Pasadena RWMP) which could be used to convey the water to Eaton Wash Spreading Grounds via the Fair Oaks Drain, near the southeast corner of the golf course.

Figure 14: Eaton Wash Spreading Grounds and Wells



### 4.3 Verdugo Basin

In 2005, CVWD completed the Verdugo Basin Groundwater Recharge Feasibility Storage and Conjunctive Use Feasibility Study (Geomatrix, 2005), a thorough evaluation of the potential for enhanced recharge in the Verdugo Basin. The report evaluated four recharge sites in order of recommendation (Figure 15):

1. Subsurface infiltration gallery at Crescenta Valley County Park and diversion of water with inflatable dams along Verdugo Wash and Dunsmuir Channel
2. Subsurface infiltration gallery along right-of-way at Dunsmuir, Shields-Eagle, and Pickens Channels and diversion of water with inflatable dams along Verdugo Wash and Dunsmuir Channel
3. Surface water recharge at Verdugo Debris Basin
4. Surface water recharge at Pickens and Dunsmuir Debris Basin

Table 16 summarizes the report’s recharge site evaluation and Table 17 presents characteristics for the two potential GWR-RW sites, based on their proximity to proposed recycled water infrastructure.

**Table 16: Verdugo Basin GWR FS Evaluation of Recharge Supplies**

Recharge Water Supply	Pros	Cons
Treated Imported Water	~6,000 afy; Available at \$440/af	High TDS but within gw objective; DBPs could cause RWQCB permitting problem
Raw Imported Water	No DBPs	FMWD has infrastructure but CVWD does not
Recycled Water	~1,000 afy; Oakmont Golf Course pay \$710/af	Requires 1,000' lift to basins above Oakmont Golf Course; Chloride is higher than gw objective; High public concern
Stormwater	High quality except oil and grease, which is removed in vadose zone	High sediment can clog basins; Large, infrequent flows limit recharge options

Source: Geomatrix, 2005

**Table 17: Characteristics of Verdugo Basin Recharge Areas**

Item	Verdugo Debris Basin	Off-Channel Infiltration Gallery at Crescenta Valley Park
Total Area	8 ac	NA
Wetted Area	6 ac	NA
Total Storage Capacity	80 to 100 af	NA
Estimated Percolation Rate	1.0 ft/day	NA
Potential Annual Recharge	430 afy	340 afy
Estimated Capital Cost	\$300,000	\$1,700,000
Estimated Annual O&M Cost	\$240,000	\$35,000
20 Year Net Present Value @ 5%	\$3,300,000; 7,700 af	\$2,100,000; 6,100 af
Unit NPV Cost	\$430/af	\$340/af

Source: Geomatrix, 2005



Figure 15: Verdugo Basin Recharge Sties

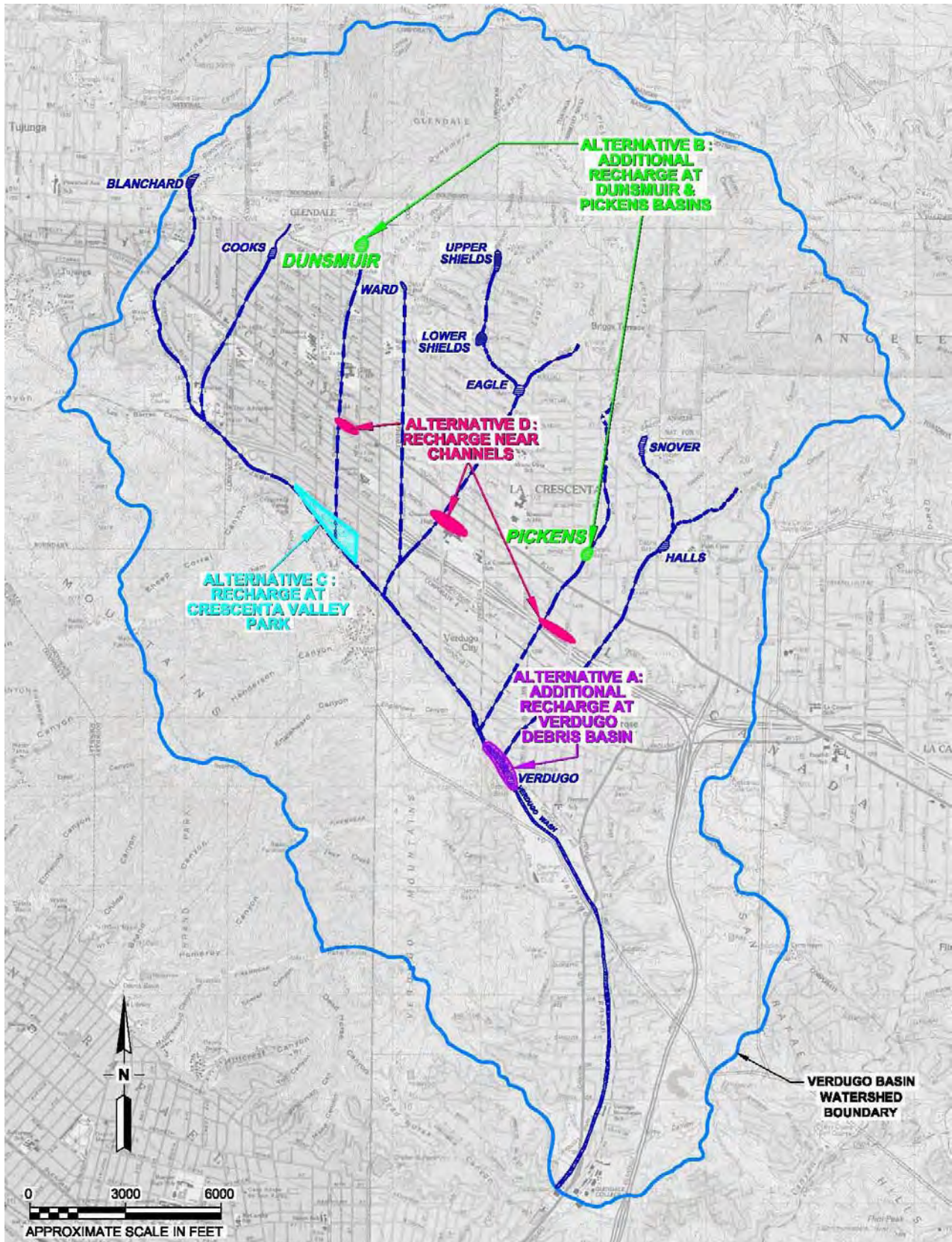

Source: Geomatrix, 2005; Figure 26

Currently, the Verdugo Basin does not have an accounting system in place to receive groundwater extraction credit for recharged water. This limits the potential for implementation of GWR-RW projects in the basin in the near-term but the potential still exists for GWR-RW projects in the future depending upon the results of additional basin evaluations. GWP has looked into recharge with infiltration galleries at the southern end of the basin even if recharge credit is not received because recharge would benefit GWP’s downgradient groundwater operations.

### 4.4 Groundwater Recharge Summary

Arroyo Seco and Eaton Wash Spreading Grounds provide the best opportunities for GWR with recycled water in the study area. Arroyo Seco has the advantage of proximity to additional recharge water supplies from stormwater captured behind Devil’s Gate Dam and proposed recycled water facilities but has limited capacity to recharge recycled water due to the close proximity of potable groundwater wells. On the other hand, Eaton Wash has a larger capacity for GWR-RW but requires conveyance facilities to receive sufficient recharge supplies. Both sites offer the prospect to work with LACFCD to increase recharge overall in the Raymond Basin and reduce project costs, particularly for Eaton Wash. **Table 18** summarizes potential GWR-RW projects in the study area.

**Table 18: Groundwater Recharge Opportunities Summary**

Spreading Grounds	Recycled Water Volume <sup>1</sup>	Unit Cost <sup>2</sup>	Assumptions
Arroyo Seco <sup>3</sup>	2,000 af (1,600 af)	\$1,700/af	<ul style="list-style-type: none"> <li>Requires construction of PWP Segments 4 &amp; 5A</li> <li>Recharge volume limited by basin capacity outside of 500 foot potable well radius;</li> <li>Primary blend supply would be Arroyo Seco surface water</li> <li>An additional blend source could be stormwater captured behind Devil’s Gate Dam</li> <li>NASA/JPL approval should be considered</li> </ul>
Eaton Wash – via Fair Oaks Drain	3,000 af	\$1,700/af	<ul style="list-style-type: none"> <li>Requires construction of PWP Segments 3 &amp; 5B</li> <li>Assumes conveyance through Fair Oaks Drain</li> <li>Primary blend supplies would be Eaton Wash surface water</li> </ul>
Eaton Wash – via Huntington	3,000 af	\$1,800/af	<ul style="list-style-type: none"> <li>Requires construction of PWP Segments 2 &amp; 6</li> <li>Primary blend supplies would be Eaton Wash surface water</li> </ul>
Arroyo Seco <sup>3</sup> & Eaton Wash	5,000 af (4,600 af)	\$1,900/af	<ul style="list-style-type: none"> <li>Requires construction of PWP Segments 4 &amp; 5A and 3 &amp; 5B</li> <li>Primary blend supplies would be Arroyo Seco and Eaton Wash surface water</li> <li>NASA/JPL approval should be considered</li> </ul>
Arroyo Seco <sup>3</sup> & Eaton Wash with Stormwater	8,600 af (7,900 af)	\$1,400/af	<ul style="list-style-type: none"> <li>Requires construction of PWP Segments 4 &amp; 5A and 3 &amp; 5B</li> <li>Requires coordination with LACFCD</li> <li>Primary blend supplies would be stormwater captured behind Devil’s Gate and Arroyo Seco surface water</li> <li>NASA/JPL approval should be considered</li> </ul>

Notes:

- Value in parentheses is for groundwater extraction credit received because new Arroyo Seco Spreading Grounds recharge basins receive 80% credit. Unit cost is based on this lower value.
- Detailed cost estimates are available in Appendix A.
- Assume only 3 west side basins used; these basins also have higher groundwater credit percentage (80%) than old basins

### 4.4.1 Groundwater Quality Betterment

One advantage of advanced treating recycled flows to be recharged in a groundwater basin is the water quality benefit provided to that basin. As illustrated in Table 15, that quality of advanced treated recycled water is far superior to imported supplies or even the existing groundwater. Introducing advanced treated recycled water into the basin may provide a mechanism to increase imported water or stormwater recharge that may otherwise be limited due to water quality objectives. The specifics of this opportunity can be clarified as this project concept is further developed.

## 5 Recommended Project Concept

By merging the non-potable recycled water plans and opportunities identified in Section 3 with the GWR-RW opportunities identified in Section 4, the partner agencies have identified a project concept that would use roughly 17,000 afy of recycled water from the LAGRWP (compared to existing use of 4,000 afy). Due to the level of development (and associated readiness-to-proceed) for various portions of the project, it is proposed to construct the project in three phases.

### 5.1 Project Phasing

Regional project phases were developed from individual GWP, LADWP, and PWP projects based upon their feasibility and timing of implementation. The phases are roughly based around five year planning segments such that Phase 1 includes projects that can be on-line in five years or less (by 2012), Phase 2 by 2017, and Phase 3 by 2022. **Table 19** presents the proposed regional project phases broken down by agency. **Figure 16** illustrates the location of project facilities and phases.

**Table 19: Recommended Regional Recycled Water Project Phases by Agency**

Project Phase	GWP Projects (afy)	LADWP Projects (afy)	PWP Projects (afy)	Total (afy)		
<b>Existing</b>	<b>2,120</b>	<b>1,920</b>	<b>-</b>	<b>4,040</b>		
<b>Phase 1 (~2010)</b>	Glendale Tee	450	LA Zoo	700	Alternative A	730
			Elysian Park <sup>1</sup>	400		
			NBC-Universal	430		
			Other	540		
	<b>Subtotal</b>	<b>450</b>	<b>2,070</b>	<b>730</b>	<b>3,250</b>	
<b>Phase 2 (~2015)</b>	Extensions	200	Remaining Tier 1	1,130	Arroyo Seco GWR	2,000
					Huntington + Spurs	630
					Mountain View	270
					Devil's Gate Area	210
	<b>Subtotal</b>	<b>200</b>	<b>1,130</b>	<b>3,110</b>	<b>4,440</b>	
<b>Phase 3 (~2020)</b>	Extensions	100	Remaining Tier 2 (Alt 1)	2,600	Eaton Wash GWR	3,000
					Altadena G.C.	170
		<b>Subtotal</b>	<b>100</b>	<b>2,600</b>	<b>3,170</b>	<b>5,870</b>
<b>Total New Use</b>	<b>750</b>	<b>5,800</b>	<b>7,010</b>	<b>13,560</b>		
<b>Total Use from LAGRWP</b>	<b>2,870</b>	<b>7,720</b>	<b>7,010</b>	<b>17,600</b>		

Note:

- The Taylor Yard portion of the Elysian Park project is near the start of construction, therefore, the demand (150 afy) and costs were not included in Phase 1 (or subsequent phases). The demand is included in Existing demands.

Figure 16: Proposed Project Phases

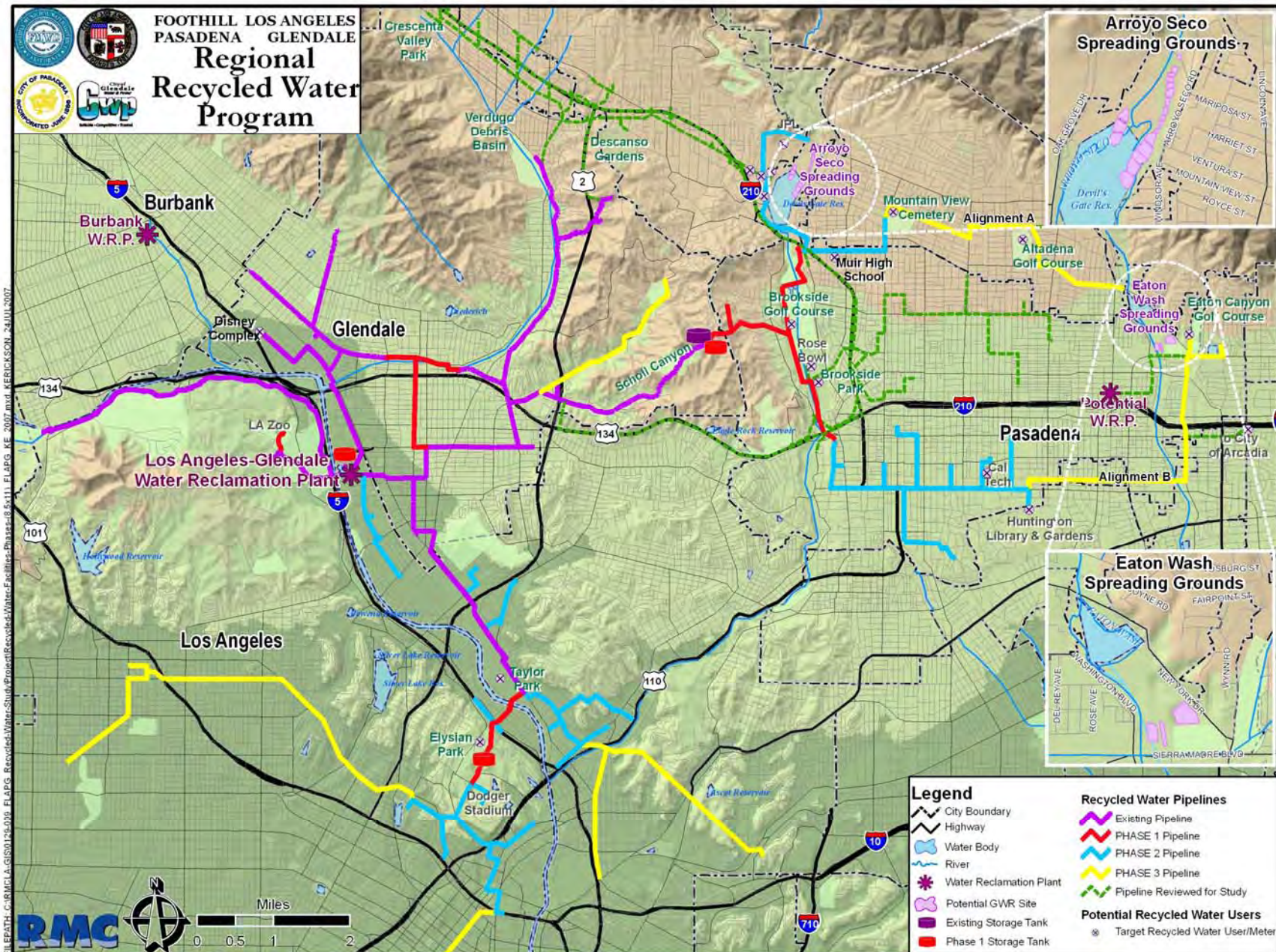

Monthly recycled water demand projections and remaining allotment for each agency through implementation of Phase 3 are presented in **Table 20** and **Figure 17**. Note that there are negative values for remaining allotments in some months. The approach would be for the agency needing water to use/purchase excess allotments from another agency.

**Table 20: Projected Recycled Water Demand and Remaining Allotment through Phase 3**

Agency	J	F	M	A	M	J	J	A	S	O	N	D	Total
<b>Potential Use through Phase 3</b>													
LADWP	225	386	515	708	836	869	869	869	836	708	515	386	<b>7,720</b>
GWP	149	149	149	149	228	362	362	362	285	251	213	213	<b>2,870</b>
PWP	35	49	81	158	226	312	322	312	226	158	81	49	<b>2,010</b>
GWR	1,200	1,050	900	0	0	0	0	0	0	0	850	1,000	<b>5,000</b>
<b>Subtotal</b>	<b>1,609</b>	<b>1,634</b>	<b>1,645</b>	<b>1,014</b>	<b>1,290</b>	<b>1,542</b>	<b>1,553</b>	<b>1,542</b>	<b>1,348</b>	<b>1,116</b>	<b>1,659</b>	<b>1,648</b>	<b>17,600</b>
<b>Remaining Allotments</b>													
LADWP	627	456	314	103	(38)	(79)	(57)	(41)	(15)	127	324	445	<b>1,084</b>
GWP	192	188	182	175	92	(46)	(37)	(31)	43	83	123	120	<b>2,166</b>
PWP	(724)	(594)	(484)	329	253	162	165	185	266	343	(428)	(551)	<b>(1,078)</b>
<b>Subtotal</b>	<b>95</b>	<b>50</b>	<b>12</b>	<b>608</b>	<b>306</b>	<b>38</b>	<b>71</b>	<b>114</b>	<b>294</b>	<b>552</b>	<b>19</b>	<b>14</b>	<b>2,172</b>
<b>Total</b>	<b>1,704</b>	<b>1,684</b>	<b>1,657</b>	<b>1,622</b>	<b>1,597</b>	<b>1,580</b>	<b>1,624</b>	<b>1,656</b>	<b>1,642</b>	<b>1,668</b>	<b>1,677</b>	<b>1,662</b>	<b>19,772</b>

Notes: Assumes 19.4 MGD of average annual effluent from LAGWRP.

**Figure 17: Projected Recycled Water Use and Remaining Allotments through Phase 3**

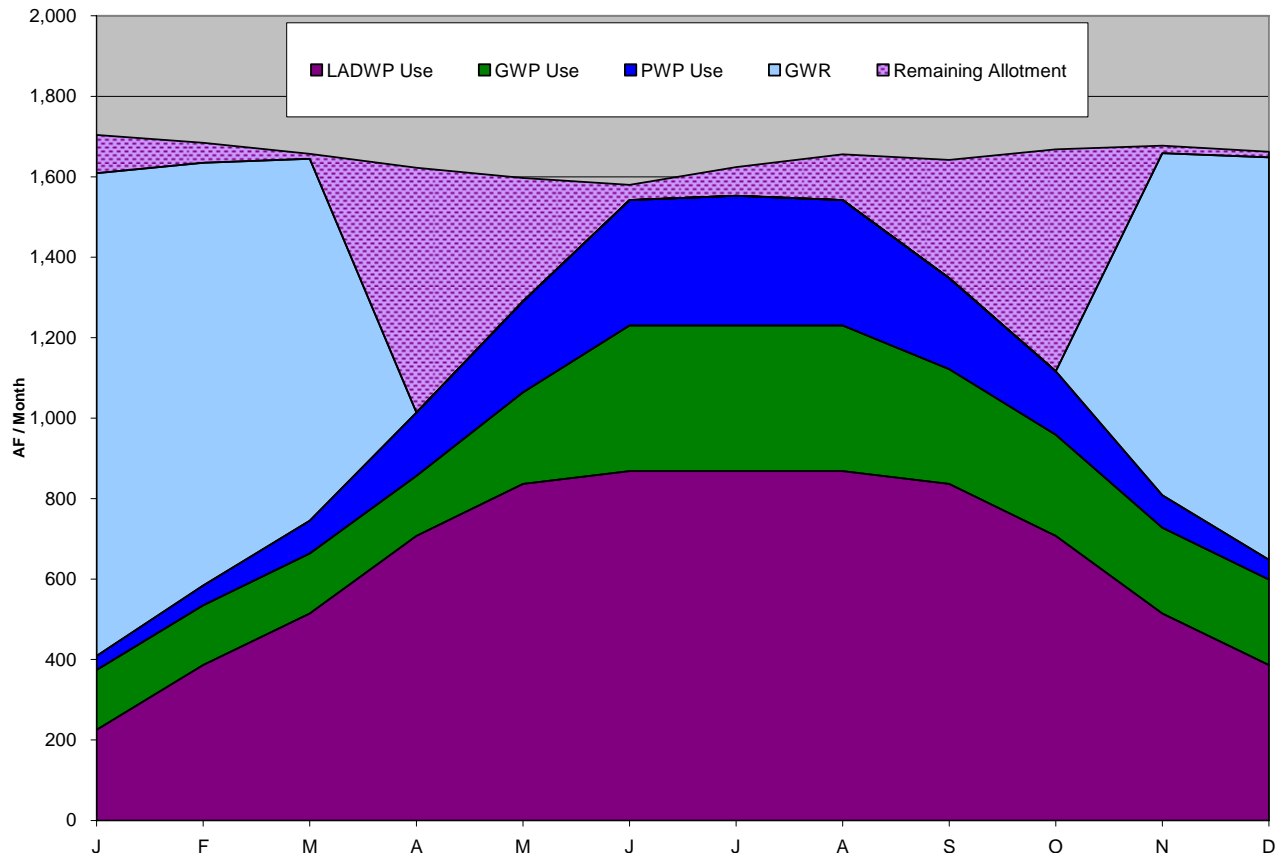

The increased beneficial use of recycled water from less than 25% to over 80% of the LAGWRP production potential through the project phases is demonstrated in **Figure 18**.

**Figure 18: Projected Use of Recycled Water and Remaining Allotment by Agency**

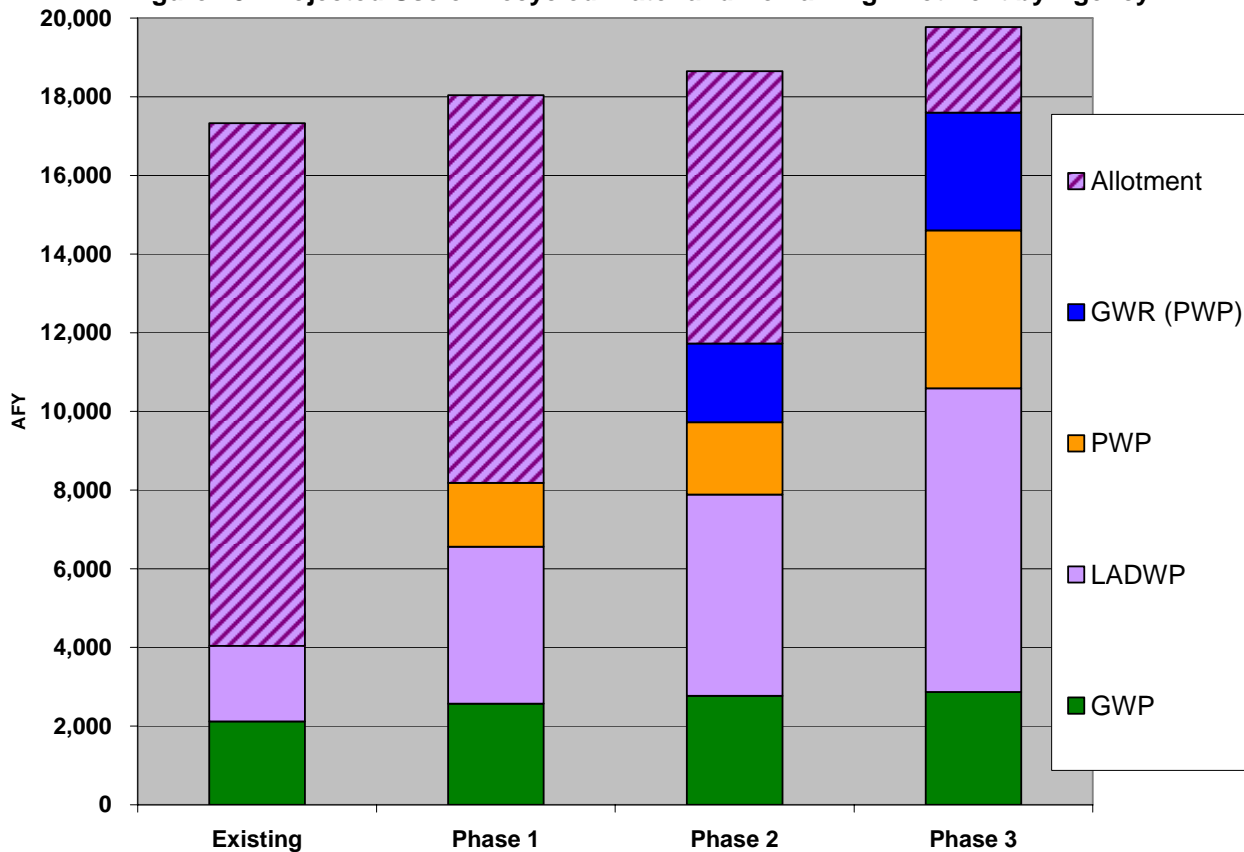

Note: GWR projections are for recharge in the PWP service area but are not included in PWP projections.

## 5.2 Cost Estimates

**Table 21** presents Phase 1 project components and **Table 22** provides capital costs by project phase.

**Table 21: Proposed Phase 1 Facilities**

Project	Pipelines	Storage	Pump Stations
LAGWRP Storage	-	5.0 MG	-
GWP – Glendale Tee	12" - 1.8 mi.	-	-
LADWP – LA Zoo	12" - 0.9 mi.	-	-
LADWP – Elysian Park	16" - 1.1 mi.	2.0 MG	570 hp by LA River
LADWP – NBC-Universal <sup>1</sup>	-	-	-
LADWP – Other	Minor	-	-
PWP – Alternative A	20" - 2.8 mi. 16" - 1.0 mi. 4" - 1.3 mi.	1.5 MG	4,500 gpm @ LAGWRP

Note:

1. Site has an existing recycled water service connection and developer will fund and install all necessary facilities, such as pipes, storage and pump stations, on-site.

Table 22: Cost Estimates by Phase

Project	Capital Cost	Comments
<b>Phase 1</b>		
	(\$ Million)	
LAGWRP Storage	\$9.5	5 MG storage tank
GWP – Glendale Tee	\$2.0	
LADWP – LA Zoo	\$5.0	
LADWP – Elysian Park	\$15.9	Includes capacity for Tier 1 completion
LADWP – NBC-Universal	\$1.0	All on-site work to be paid by customer
LADWP – Other	\$1.0	All on-site work to be paid by customers
PWP – Alternative A	\$11.1	Includes capacity for expansion
<b>Total Phase 1</b>	<b>\$45.5</b>	
<b>Phase 2</b>		
GWP – Expansion	\$4.0	Includes 0.2 MG Lower Scholl Canyon storage
LADWP – Remaining Tier 1	\$50.0	Total Tier 1 = \$64.5M
PWP – Alt A Extensions	\$16.2	Includes VWC demands
Arroyo Seco GWR	\$42.2	Includes 5 MGD of MF/RO/UV
<b>Total Phase 2</b>	<b>\$112.4</b>	
<b>Phase 3</b>		
GWP – Expansion	\$2.0	
LADWP – Remaining Tier 2	\$35.0	Total Tier 2 = \$100M
Eaton Wash GWR	\$58.0	Includes 7 MGD of MF/RO/UV
<b>Total Phase 3</b>	<b>\$95.0</b>	
<b>Total Project Cost</b>	<b>\$252.9</b>	

Note: Detailed cost estimates for PWP and GWR are provided in Appendix A and GWP and LADWP cost estimates were provided by staff.

### 5.3 Funding Opportunities

With an overall project concept cost of roughly \$250 million, outside funding is needed to achieve the full potential of this project. Funding opportunities generally include the federal government and state agencies (SWRCB, DWR, etc.). Due to the diversity of project components and resources, an array of local funding support options may also exist. Examples include:

- MWD Local Resources Program (LRP) offers programs providing incentives (up to \$250/af) for water recycling and local supply development that offsets use of imported water
- FMWD and/or VWC for use (purchase) of recycled water supplied through PWP’s portion of the recycled water system
- LACFCD through developing GWR of surface water, stormwater and recycled water

- Raymond Basin Management Board or proponents for other recharge projects for water quality benefits of GWR-RW to the Raymond Basin
- LADPW for avoided costs of collection system expansion downstream of LAGWRP
- Southern California Edison or other energy suppliers through the California Water-Energy Partnership for use of mini-turbines in place of pressure reducing valves proposed by PWP

A summary of state and federal funding opportunities is presented in **Table 23**, **Table 24**, and

**Table 25**. Of the funding opportunities noted, two opportunities stand out: 1) LA IRWMP / Prop 84; and 2) US Bureau of Reclamation (USBR) Title XVI.

**Table 23: State Funding Mechanisms**

Program	Description	Funding Available	Applicable Project Components
<b>Prop 50, Ch. 4:</b> DHS Safe Drinking Water Grants	Southern California projects to reduce demand on the Colorado River	<u>Project</u> \$20M	Recycled water
<b>Prop 82:</b> Water Supply	New local water supply projects	<u>Project</u> \$5M	Recycled water
<b>Prop 84, Ch. 2:</b> Safe Drinking Water	Similar to Prop 50, Ch. 8: IRWMP	<u>LA / Ventura</u> \$215M <u>Interregional</u> \$100M	Recycled water; GWR; Stormwater
<b>Prop 84, Ch. 3:</b> Flood Control	Flood control projects	<u>Interregional</u> \$275M	GWR of stormwater
<b>Prop 84, Ch. 4:</b> Planning	Planning and feasibility studies; climate change impacts on flood and water systems; integration of flood and water systems	<u>Interregional</u> \$65M	GWR of stormwater
<b>Prop 84, Ch. 5:</b> Protection	SWRCB matching grants to prevent stormwater contamination	<u>Interregional</u> \$90M	GWR of stormwater
<b>Prop 84, Ch. 9:</b> Sustainable	Urban greening to reduce energy, conserve water, and improve water quality	<u>Interregional</u> \$90M	Hahamongna Park; Eaton Wash Park;
	Competitive grants for local and regional parks	<u>Interregional</u> \$400M	Hahamongna Park; Eaton Wash Park;
	Planning grants and incentives for regional and local land use plans designed to promote water conservation, protect natural lands, and revitalize communities	<u>Interregional</u> \$90M	Hahamongna Park; Eaton Wash Park;
<b>Prop 1E:</b> Flood Management	Grants for stormwater flood management projects	<u>Interregional</u> \$300M	GWR of stormwater
	Protection, creation, and enhancement of flood protection corridors and bypasses	<u>Interregional</u> \$290M	GWR of stormwater
	Grants for stormwater flood management projects not part of State Plan for Flood Control; projects with multiple benefits, comply with Basin Plan, and consistent with IRWMP	<u>Interregional</u> \$300M	GWR of stormwater
<b>SWRCB Water Recycling Funding Program</b>	Part A) Study feasibility of water recycling and prepare a facilities Part B) Support design and construction of water recycling facilities.	<u>Project</u> A) \$75k B) \$3M	Recycled Water



Program	Description	Funding Available	Applicable Project Components
Land & Water Conservation Fund	<b>CA Dept of Parks &amp; Rec</b> – for acquisition or development projects for outdoor recreation	TBD	Hahamongna Park; Eaton Wash Park;
Environment Enhancement & Mitigation (EEM) Program	<b>CA Resources Agency</b> – for acquisition, restoration, or enhancement of natural areas	pending	Hahamongna Park; Eaton Wash Park;
AB303 Local Groundwater Assistance Grant	Groundwater data collection, modeling, monitoring and management studies; monitoring programs and installation of equipment; basin management; and development of information systems	\$250k per applicant	GWR

**Table 24: State & Federal Loan Mechanisms**

Program	Description	Funding Available	Applicable Project Components
Clean Water State Revolving Fund Program	<b>SWRCB / USEPA</b> - for publicly owned wastewater treatment facilities		LAGWRP upgrades
Infrastructure SRF Program	<b>i-bank</b> - Financing for construction and/or repair of publicly owned water supply and treatment systems		LAGWRP upgrades

**Table 25: Federal Funding Opportunities**

Program	Description	Funding Available	Applicable Project Components
Desalination and Water Purification Research and Development Program	<b>USBR</b> - Address desalting and water purification needs in order to increase the supply of usable water available to the U.S.	pending	LAGWRP upgrades
Challenge Grant Program	<b>USBR</b> - Projects focused on water conservation, efficiency, and water marketing	pending	Recycled water
Watershed Protection and Flood Prevention	Natural Resources Conservation Services - conservation, development, utilization, and disposal of water	pending	Recycled water

### 5.3.1 IRWMP

Integrated regional water management planning has become a primary pathway for water supply and water quality project funding in recent years. The LA IRWMP was prepared in 2006 (subsequently updated) to pursue funding available under Prop 50, Chapter 8 (IRWMP Program). The LA Region received \$25 million in implementation funding via Round 1, but has decided not to pursue funding during Round 2. Instead, the region is focusing on Prop 84 grant funding that will become available in 2008. The LA/Ventura region will receive \$215 million directly, and could compete for a portion of the \$100 million interregional funding that could be available. The LA IRWMP identified the following five primary objectives:

- **Improve Water Supply** - Increase water supply reliability and increase reclaimed water usage

- **Improve Water Quality** - Comply with water quality regulations and improve groundwater quality
- **Enhance Habitat** - Protect, restore & enhance natural processes & habitats
- **Enhance Open Space, Recreation** - Increase watershed friendly recreational space
- **Sustain Communities** - Maintain & enhance public infrastructure

Updated project descriptions in the LA IRWMP project database for Phase 1 and the full project are included in Appendix C and D, respectively. Project characteristics that align with this program are listed in **Table 26**.

**Table 26: CeLAC & LA IRWMP Objectives**

LA IRWMP Objectives	Primary (P) Secondary (S) Objective		Comments
	Phase 1	Full Project	
<b>Water Supply Objectives</b>			
Reduced reliance on imported water	P	P	Recycled water replaces imported water
Increased water supply reliability	P	P	Recycled water is a local, reliable supply
Increased operational flexibility	S	P	Decreased potable demand increases available potable capacity; GWR creates flexible groundwater extraction options
Increased water reclamation or recycling	P	P	Phase 1 and full project use 3,300 afy and 13,700 afy of recycled water, respectively
Increased GWR, recovery, and management	-	P	Full project proposes use of 5,000 afy of recycled water for GWR
<b>Water Quality Objectives</b>			
Storm water or urban runoff water quality	-	S	GWR with recycled water would also recharge storm water, which reduces storm water flows
Receiving water body quality improvement	S	S	Recycled water use reduces wastewater flows to Hyperion, which discharges to Santa Monica Bay
Improved flood management	-	S	GWR with recycled water would also recharge storm water, which reduces storm water flows
Groundwater protection or improvement	-	P	Advanced treatment of recycled water would reduce TDS below background levels in Raymond Basin
<b>Beneficial Use Objectives</b>			
Restoration and protection of habitat	-	S	Recharge basins could provide restored and/or new habitat
Creation or enhancement of public access, recreation or open space	-	S	Recharge basins provide restored and/or new open space

### 5.3.2 USBR Title XVI

PWP has been authorized to receive grant funding from USBR through the Title XVI program for recycled water. This program provides a 25% match up to \$20 million. PWP completed the RWFS to begin the process of funding pursuit, but has ceased to continue due to project costs. It is expected that as project integration and enhancements improve the cost-effectiveness of the PWP portion of the project, PWP can re-engage with USBR to pursue appropriations to fund the construction of the project.

## 5.4 Benefits Identification

Generally, the primary benefit of water recycling is the offset in use of limited potable water supplies. In this setting, imported water from MWD is the most likely water supply to be replaced by recycled water. Other general water recycling benefits include:

- Increased local control of supply
- Increased water supply reliability
- Lower energy consumption (vs. imported water)
- Contribution to meeting “green” initiatives for each project partner (Glendale’s “Commitment to the Environment”; Los Angeles’ “Green LA”; Pasadena’s “Think Green”)
- Support of “portfolio theory” of water supplies (maximize yields while also reducing variance)

Specific to non-potable water recycling, additional benefits are accrued:

- Avoided use of potable supplies for non-potable demands
- Avoided potable water treatment (chlorination) and distribution costs

Specific to GWR-RW, a new, cost-effective potable water supply is created. GWR-RW can also provide the following benefits to the underlying groundwater basin:

- Increased groundwater levels
- Improved water quality
- Reduced extraction stress on the groundwater basin
- Water quality “credit” to enable expanded recharge with either stormwater or imported supplies not meeting Basin Plan water quality objectives

Incorporation of stormwater as a blend supply for GWR-RW could provide the following benefits:

- Maximized beneficial use of stormwater
- Low cost source of water for recharge
- Possibility for cost-sharing with LACFCD

### 5.4.1 Water Supply Benefit

Although a complete benefit cost analysis is beyond the scope of this TM, it is valuable to identify the benefit associated with at least the water supply reliability portion of the benefits listed above.

From a benefit assessment perspective, the use of recycled water would replace the marginal water supply of the study area, which is imported water provided by MWD. The LA IRWMP Proposition (Prop) 50, Round 1, Step 2 grant application (RMC, 2006) included a monetary benefit assessment of replacing imported water use. The remainder of this section is an excerpt from that application’s water supply benefit assessment.

Primary water supply benefits were quantified and supported by existing documentation. Monetary values for water supply were developed in the IRWM Plan Benefits Assessment Framework (see Appendix E) and benefit values are largely based on avoided costs. **Table 27** summarizes the major benefit types, the benefit estimate source and the monetary value used.

**Table 27: Water Supply Benefits Assessment Framework Summary**

Benefit Type	Benefit Estimate Source	Monetary Value Used
Avoided cost	MWD Full Service Tier 1 Rate	Combined water supply avoided cost in \$ per afy that varies for selected years (Table 28)
Increased Reliability	MWD Shortage Surcharge Rate	

**Table 28** shows the combined water supply avoided cost per acre foot for selected years. These values can be applied to a present value analysis to evaluate the lifecycle benefits and costs for the project.

**Table 28: Water Supply Avoided Costs (\$/af)**

	2007	2010	2020	2030	2040
MWD Full Service Tier 1 High Estimate	\$478	\$601	\$808	\$1,085	\$1,459
MWD Full Service Tier 1 Low Estimate	\$478	\$555	\$677	\$866	\$1,164
<i>Average of Tier 1 Estimates</i>	<i>\$478</i>	<i>\$578</i>	<i>\$742</i>	<i>\$976</i>	<i>\$1,311</i>
MWD Shortage Surcharge Rate or Dry Year Rate <sup>1</sup>	\$1,434	\$1,734	\$2,226	\$2,928	\$3,933
Combined Avoided Cost of Water Supply Benefit <sup>2</sup>	\$765	\$925	\$1,187	\$1,562	\$2,098
Inferred Reliability Surcharge <sup>3</sup>	\$287	\$347	\$445	\$586	\$787

Source: LA IRWMP Prop 50 Round 1, Step 2 Grant Application (RMC, 2006)

Notes: Projected values in 2005 dollars.

1. Equal to three times the average MWD Full Service Tier 1 rate. The shortage surcharge is applied to reflect the dry year probability (30%), which indicates that the shortage surcharge may be applicable 3 out of every 10 years. See Appendix E for further explanation.
2. Calculated by [Average Tier 1 Rate \* 70% + Dry Year Rate \* 30%]
3. Subtract Average of Tier 1 Estimates from Combined Avoided Cost of Water Supply Benefit.

A simpler approach to avoided costs combines the Phase 1 project costs with avoided costs of MWD imported water purchase. The Phase 1 project capital costs (\$44.2 million) were amortized at 4.0% over 20 years plus a unit O&M (for capital facilities and operating, particularly pumping) cost of \$250/af was estimated for the exercise. This was compared with the MWD 2007 Tier 2 rate of \$574/af plus a unit O&M (for distribution pumping) cost of \$25/af. Then, potential funding opportunities were incorporated into the Phase 1 project capital and O&M costs. Project construction funding of \$5 million each from Prop 84 and Title XVI as well \$250/af subsidy from the MWD LRP was assumed. As shown in **Figure 19**, the inclusion of funding reduces costs to a similar level as imported water from MWD. Note that this analysis does not consider any of the benefits described earlier in this section than the avoided cost of imported water.

Figure 19: Comparison of Phase 1 Costs vs. Avoided Cost of Imported Water

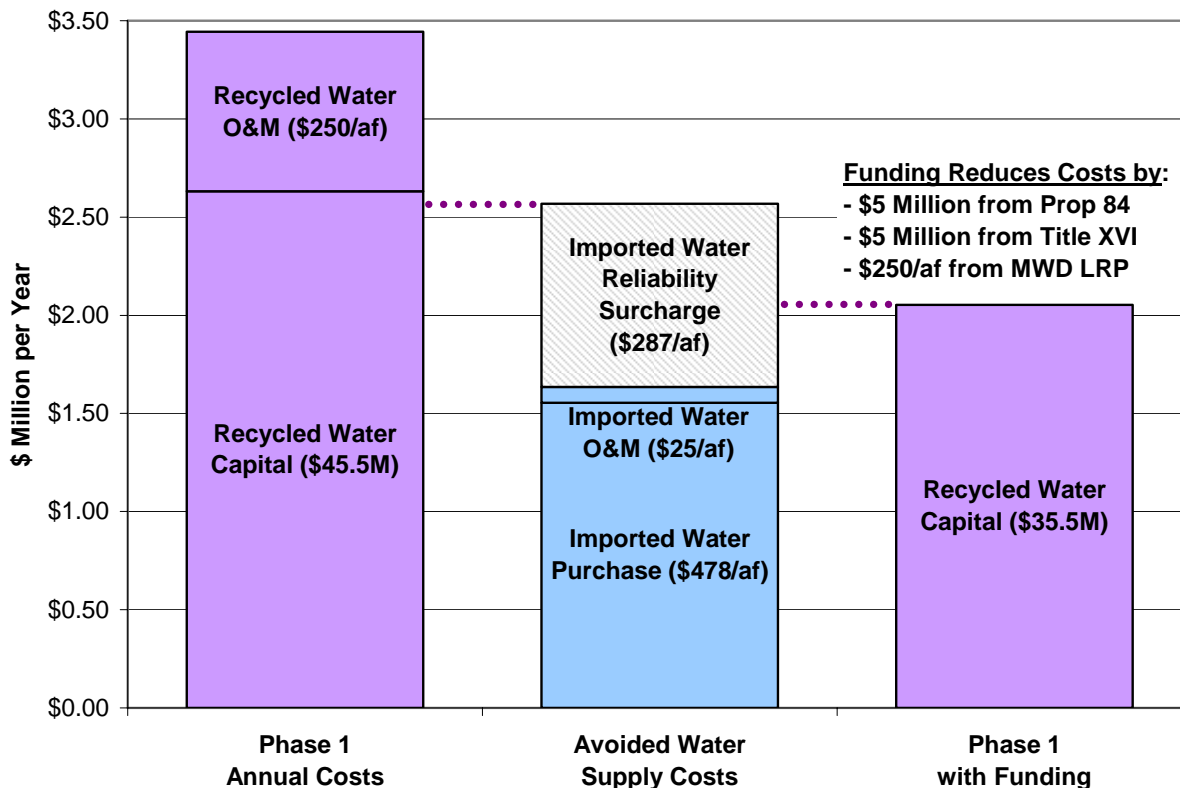

Note: Phase 1 includes 3,250 afy.

## 6 Phase 1 Implementation Plan

The primary focus of near-term activities associated with the project is to align with Prop 84 funding. That will require that Phase 1 project components be fully developed and ready to proceed based on the Prop 84 funding schedule. Based on our understanding of the current preliminary Prop 84 schedule, there are two key dates to use to develop project schedules:

1. Submittal of the grant application in mid-2008
2. Construction start date of early 2010 (to maximize scoring of application)

In addition, as much progress as possible should be made developing the project details by the estimated grant application submittal date (mid-2008). Key near-term activities include:

- Project Partner Memorandum of Understanding (MOU)
- Facilities Plan/10% Design
- Environmental documentation

Table 29 presents a proposed schedule for Phase 1 project components to align with Prop 84 requirements.

**Table 29: Status of Phase 1 Projects**

Component	Start	Finish	Comments
Pre-Design	ongoing	Jun '08	<ul style="list-style-type: none"> <li>GWP has completed work</li> <li>LADWP has started work</li> <li>PWP plans to start work by Jan '08 and complete work by Jun '08</li> </ul>
Environmental Documentation	ongoing	Jun '08	<ul style="list-style-type: none"> <li>GWP &amp; LADWP have started work</li> <li>PWP plans to start work by Jan '08 and complete work by Jun '08</li> </ul>
Project Partner MOU	-	Jun '08	<ul style="list-style-type: none"> <li>GWP, LADWP, and PWP are developing an MOU and should be complete by Jun '08</li> </ul>
Final Design	Jul '08	Dec '09	<ul style="list-style-type: none"> <li>No agency has started work but all designs should be completed by Dec '09</li> </ul>
Construction	Jan '10	-	<ul style="list-style-type: none"> <li>All projects will start construction by Jan '10 based on the current schedule</li> </ul>

Notes: Based on the current schedule for LADWP's Elysian Park Water Recycling Project, the earlier phases that include Taylor Yard will be completed by the estimated Prop 84 grant execution date of January 1, 2010 so this work could either be excluded from the grant application or applied as matching funds, depending upon the matching contribution start date to be determined in Prop 84 grant application guidance documents.

As previously mentioned, the focus of CeLAC RWRP activities over the next year should be to make progress in definition (design, environmental documentation, etc.) of Phase 1 projects to increase the likelihood of selection for inclusion in a Prop 84 grant application and related readiness to proceed considerations.

## References

- Black & Veatch (B&V), June 1996. *Los Angeles Zoo Recycled Water Feasibility Study; Final Report*.
- Bookman-Edmonston (BE), April 2004. *Crescenta Valley Water District Recycled Water Feasibility Study. CVWD Project E-725*.
- CH2MHILL and CDM (CH:CDM), December 2006(a). *Los Angeles Recycled Water Master Plan*.
- CH:CDM, December 2006(b). *Los Angeles Final Integrated Resources Plan*.
- CH:CDM, November 2006(c). *Los Angeles Integrated Resources Plan Final Environmental Impact Report*. SCH No. 2004071091; SCAG No. I20040466
- Glendale Water and Power (GWP), August 2006. *City of Glendale Water Supply Evaluation for Downtown Specific Plan*.
- GWP, 2007. Personal communication (p.c.) with Rosanna Lau.
- Geomatrix Consultants Inc. (Geomatrix), May 2005. *Verdugo Basin Groundwater Recharge Feasibility Storage and Conjunctive Use Feasibility Study*. Prepared for Crescenta Valley Water District. [Verdugo Basin GWR FS]
- Los Angeles Department of Water and Power (LADWP), 2007. Personal communication (p.c.) with Amy Lee Jones Webb and Paul Liu.
- Los Angeles County Flood Control District (LACFCD), 2007. E-mail from Daniel Sharp.
- LACFCD, December 1997. *Devil's Gate Dam Diversion System to Eaton Dam and Arroyo Seco Spreading Grounds (Preliminary Draft)*.
- Los Angeles Regional Water Quality Control Board (RWQCB), November 14, 2006. *Water Recycling Requirements for Title 22 Recycled Water Issued to City of Los Angeles (Los Angeles-Glendale Water Reclamation Plant)*.
- Los Angeles RWQCB, 1994. *Water Quality Control Plan: Los Angeles Region Basin Plan for the Coastal Water shed of Los Angeles and Ventura Counties*.
- MWH, May 2005. *Pasadena Water and Power Recycled Water Feasibility Study – Final Report*.
- Pasadena, City of, September 2003. *Arroyo Seco Master Plans: Hahamongna Watershed Park Master Plan*.
- Pasadena Water and Power (PWP), 2007a. Personal communication (p.c.) with Roumiana Karakanova.
- Pasadena Water and Power (PWP), 2007b. Personal communication (p.c.) with Brad Boman.
- RMC Water and Environment (RMC), June 2006. *Greater Los Angeles County Region IRWMP Step 2 Implementation Grant for Prop 50, Chapter 8, Round 1*.
- Stetson Engineers Inc. (Stetson), March 2006. *Draft Criteria for Delivery of Supplemental Water. For Raymond Basin Management Board*.

**Appendix A**  
-  
**Detailed Cost Estimates**





**Project: CeLAC Regional Water Recycling Project**  
**Aspect: Cost Estimate Summary for PWP & GWR**

Estimate Type: Planning Level

Elements	PWP Non-Potable Reuse Alternatives:			
	Alternative A	Alt A + Upsize	Alternative B	CeLAC Phase 2
Raw Const. Cost	\$ 4,202,000	\$ 6,558,000	\$ 20,918,000	\$ 15,398,000
Project Contingency 30%	\$ 1,261,000	\$ 1,967,000	\$ 6,275,000	\$ 4,619,000
Engr., Legal, Admin. 30%	\$ 1,639,000	\$ 2,558,000	\$ 8,158,000	\$ 6,005,000
<b>Total Capital Cost</b>	<b>\$ 7,102,000</b>	<b>\$ 11,083,000</b>	<b>\$ 35,351,000</b>	<b>\$ 26,022,000</b>
Annualized Capital Cost 0.073	\$ 518,400	\$ 809,100	\$ 2,580,600	\$ 1,899,600
Total O&M Cost	\$ 222,690	\$ 246,290	\$ 605,660	\$ 609,520
<b>Total Annual Cost</b>	<b>\$ 741,090</b>	<b>\$ 1,055,390</b>	<b>\$ 3,186,260</b>	<b>\$ 2,509,120</b>
Estimated Annual Segment Yield (AFY)	730	730	2,020	1,840
<b>Estimated Annual Unit Cost (\$/AFY)</b>	<b>\$1,020</b>	<b>\$1,450</b>	<b>\$1,580</b>	<b>\$1,360</b>

\*Includes VWC demands

Elements	Groundwater Recharge at:				
	Arroyo Seco	Eaton Wash (via Fair Oaks)	Eaton Wash (via Huntington)	Arroyo Seco & Eaton Wash	w- Stormwater & Recycled Water
Raw Const. Cost	\$ 32,570,500	\$ 43,106,500	\$ 46,654,500	\$ 65,085,000	\$ 70,878,000
Project Contingency 30%	\$ 9,771,000	\$ 12,932,000	\$ 13,996,000	\$ 19,526,000	\$ 21,263,000
Engr., Legal, Admin. 30%	\$ 9,771,000	\$ 12,932,000	\$ 13,996,000	\$ 25,383,000	\$ 27,642,000
<b>Total Capital Cost</b>	<b>\$ 52,113,000</b>	<b>\$ 68,971,000</b>	<b>\$ 74,647,000</b>	<b>\$ 109,994,000</b>	<b>\$ 119,783,000</b>
Annualized Capital Cost 0.073	\$ 3,804,200	\$ 5,034,900	\$ 5,449,200	\$ 8,029,600	\$ 8,744,200
Total O&M Cost	\$ 2,045,750	\$ 2,960,130	\$ 2,975,390	\$ 4,476,560	\$ 5,739,510
<b>Total Annual Cost</b>	<b>\$ 5,849,950</b>	<b>\$ 7,995,030</b>	<b>\$ 8,424,590</b>	<b>\$ 12,506,160</b>	<b>\$ 14,483,710</b>
Estimated Annual Segment Yield (AFY)	3,450	4,810	4,730	6,620	10,270
<b>Estimated Annual Unit Cost (\$/AFY)</b>	<b>\$1,700</b>	<b>\$1,660</b>	<b>\$1,780</b>	<b>\$1,890</b>	<b>\$1,410</b>



**Project: CeLAC Regional Water Recycling Project**

**Aspect: General Unit Cost Criteria**

Estimate Type: Planning Level

Cost Criteria		
Project Contingency	30%	of total construction cost
Engineering/Admin/Legal	30%	of total construction cost including contingency

**Unit Costs - Capital**

Item	Reference Cost (Unadjusted \$)	Unit Cost	Units	Reference(s)	Description / Assumptions
<b>Pipe</b>					
Pipe (installed open cut)	\$	10.00	\$/in dia/LF		
Pipe (hung on bridge)	\$	15.00	\$/in dia/LF		
Pipe (installed bore and jack)	\$	20.00	\$/in dia/LF		
Pipe (installed microtunnel)	\$	25.00	\$/in dia/LF		
Appurtenances		10%			
<b>Storage</b>					
Abvoeground Steel Storage Tank	\$	1.00	\$/GAL	MWH, 2005	
Below Ground Heavy Duty Storage Tank	\$	1.88	\$/GAL	CH:CDM, 2006; App S	for 10MG storage tank
LAWRP Wastewater Storage (with Real Time Control)	\$ 20,000,000	\$ 22,220,000	LS		LA IRP; Section 3.5, Table 1
LAWRP Recycled Water Storage (with Real Time Control)	\$ 8,000,000	\$ 8,890,000	LS		LA IRP; Section 3.5, Table 1
<b>Treatment</b>					
LAGWRP Upgrade to Advanced Treatment (20 MGD)	\$ 105,000,000	\$ 69,030,000	LS	CH:CDM, 2006; App S	LA IRP; Section 3.5, Table 2
MF/RO	\$	4,500,000	\$/MGD		
Advanced Oxidation	\$	800,000	\$/MGD		Includes high intensity UV and hydrogen peroxide
<b>Pump Station</b>					
Formula	Base Cost:	\$ 290,000	Base Price		Total cost is base cost plus variable cost
	Variable Cost:	\$ 1,860	\$/hp		
Booster Pump	\$	1,400	\$/hp		
Pressure Reducing Station	\$	200,000	\$/EA	MWH, 2005	
<b>Recharge Basins</b>					
Earthwork	\$	5.00	\$/CY		
<b>Land</b>					
Right of Way	\$	8,000	\$/ACRE		
Right of Way	\$	8,000	\$/ACRE		
<b>Water</b>					
Pipe (installed open cut)	\$	5.00	\$/in dia/LF		
Pipe (hung on bridge)	\$	10.00	\$/in dia/LF		
<b>Other</b>					
Customer Connections	\$	8,000	\$/ACRE		
Pipe (hung on bridge)	\$	10.00	\$/in dia/LF		



**Project: CeLAC Regional Water Recycling Project**  
**Aspect: General Unit Cost Criteria**

Estimate Type: Planning Level

Unit Costs - O&M				
Item	Unit Cost	Units	Reference(s)	Description / Assumptions
<b>Pipe</b>				
Pipe	1%	Allowance		Percent of pipe capital cost
Appurtenances	1%	Allowance		Percent of appurtenances capital cost
<b>Storage</b>				
Aboveground Steel Storage Tank	10%	Allowance		
Below Ground Heavy Duty Storage Tank	10%	Allowance		
0				
<b>Treatment</b>				
MF/RO	\$	1,300	\$/MG	CH:CDM, 2006; App S
Advanced Oxidation	\$	600	\$/MG	
0				
<b>Pump Station</b>				
Maintenance	10%	Allowance		
Electricity	\$	0.15	\$/kWh	
0				
Recharge Basins	\$	10,000	\$/AC	
Annual Maintenance				
0				
<b>Land</b>				
<b>Land</b>				
Right of Way				
Right of Way				
0				
<b>Water</b>				
PWP to GWP for RW System O&M	\$	92	\$/AFY	MWH, 2005
PWP to GWP for RW Pumping	\$	130	\$/AFY	MWH, 2005
PWP to GWP for RW Commodity Charge	\$	31	\$/AFY	MWH, 2005



**Project: CeLAC Regional Water Recycling Project**

**Aspect: PWP - Alternative A**

Estimate Type: Planning Level      **Estimated Annual Segment Yield = 730 AFY**

**Capital Costs**

Item	Size	Units	Quantity	Unit	Unit Cost	Total Cost	Notes
Pipe	4	IN	6,691	LF	\$ 10.00	\$ 268,000	
Pipe	8	IN	5,026	LF	\$ 10.00	\$ 402,000	
Pipe	12	IN	14,932	LF	\$ 10.00	\$ 1,792,000	
Pipe Crossings						\$ 200,000	
Pressure Reducing Stations			2	EA	\$ 200,000	\$ 400,000	
Additional Pumping Capacity @ LAGWRP						\$ 200,000	4,500 gpm
Storage Tank @ Scholl Canyon Landfill			740,000	GAL	\$1.00	\$ 740,000	
Customer Connections						\$ 200,000	
<b>RAW CONSTRUCTION COST</b>						<b>\$ 4,202,000</b>	

**O&M Costs**

Item	Size	Units	Quantity	Unit	Unit Cost	Total Cost	Notes
PWP to GWP for RW System O&M			730	AFY	\$ 92	\$ 67,160	
PWP to GWP for RW Pumping			730	AFY	\$ 130	\$ 94,900	
Pipe			\$ 2,462,000	LS	1%	\$ 24,600	
Pipe Crossings			\$ 200,000	LS	1%	\$ 2,000	
Pressure Reducing Stations			\$ 400,000	LS	1%	\$ 4,000	
Storage Tank @ Scholl Canyon Landfill			\$ 740,000	LS	1%	\$ 7,400	
Recycled Water Purchase			730	AFY	\$ 31	\$ 22,630	
<b>O&amp;M COST</b>						<b>\$ 222,690</b>	



**Project: CeLAC Regional Water Recycling Project**

**Aspect: PWP - Alternative A - Upsized for Expansion**

Estimate Type: Planning Level      **Estimated Annual Segment Yield = 730 AFY**

**Capital Costs**

Item	Size	Units	Quantity	Unit	Unit Cost	Total Cost	Notes
Alt A Pipe - 4"	4	IN	6,691	LF	\$ 10.00	\$ 268,000	
Alt A Pipe - 8"	16	IN	5,026	LF	\$ 10.00	\$ 804,000	
Alt A Pipe - 12"	20	IN	14,932	LF	\$ 10.00	\$ 2,986,000	
Pipe Crossings						\$ 200,000	
Pressure Reducing Stations			2	EA	\$ 200,000	\$ 400,000	
Additional Pumping Capacity @ LAGWRP						\$ 200,000	4,500 gpm
Storage Tank @ Scholl Canyon Landfill			1,500,000	GAL	\$1.00	\$ 1,500,000	Storage requirements to be reassessed during pre-design
Customer Connections						\$ 200,000	
<b>RAW CONSTRUCTION COST</b>						<b>\$ 6,558,000</b>	

**O&M Costs**

Item	Size	Units	Quantity	Unit	Unit Cost	Total Cost	Notes
PWP to GWP for RW System O&M			730	AFY	\$ 92	\$ 67,160	
PWP to GWP for RW Pumping			730	AFY	\$ 130	\$ 94,900	
Alt A Pipe			\$ 4,058,000	LS	1%	\$ 40,600	
Pipe Crossings			\$ 200,000	LS	1%	\$ 2,000	
Pressure Reducing Stations			\$ 400,000	LS	1%	\$ 4,000	
Storage Tank @ Scholl Canyon Landfill			\$ 1,500,000	LS	1%	\$ 15,000	
Recycled Water Purchase			730	AFY	\$ 31	\$ 22,630	
<b>O&amp;M COST</b>						<b>\$ 246,290</b>	



**Project: CeLAC Regional Water Recycling Project**

**Aspect: PWP - Alternative B**

Estimate Type: Planning Level

**Estimated Annual Segment Yield = 2,020 AFY**

**Capital Costs**

Item	Size	Units	Quantity	Unit	Unit Cost	Total Cost	Notes
Pipe	4	IN	30,526	LF	\$ 10.00	\$ 1,221,000	
Pipe	6	IN	19,924	LF	\$ 10.00	\$ 1,195,000	
Pipe	8	IN	12,687	LF	\$ 10.00	\$ 1,015,000	
Pipe	12	IN	11,770	LF	\$ 10.00	\$ 1,412,000	
Pipe	16	IN	36,647	LF	\$ 10.00	\$ 5,864,000	
Pipe	20	IN	18,606	LF	\$ 10.00	\$ 3,721,000	
Pipe Crossings						\$ 400,000	
Pressure Reducing Stations			2	EA	\$ 200,000	\$ 400,000	
Additional Pumping Capacity @ LAGWRP						\$ 200,000	4,500 gpm
Storage Tank @ Scholl Canyon Landfill			3,690,000	GAL	\$1.00	\$ 3,690,000	
Customer Connections						\$ 1,800,000	
<b>RAW CONSTRUCTION COST</b>						<b>\$ 20,918,000</b>	

**O&M Costs**

Item	Size	Units	Quantity	Unit	Unit Cost	Total Cost	Notes
PWP to GWP for RW System O&M			2,020	AFY	\$ 92	\$ 185,840	
PWP to GWP for RW Pumping			2,020	AFY	\$ 130	\$ 262,600	
Pipe			\$ 14,428,000	LS	0.5%	\$ 72,100	
Pipe Crossings			\$ 400,000	LS	0.5%	\$ 2,000	
Pressure Reducing Stations			\$ 400,000	LS	0.5%	\$ 2,000	
Storage Tank @ Scholl Canyon Landfill			\$ 3,690,000	LS	0.5%	\$ 18,500	
Recycled Water Purchase			2,020	AFY	\$ 31	\$ 62,620	
<b>O&amp;M COST</b>						<b>\$ 605,660</b>	



**Project: CeLAC Regional Water Recycling Project**

**Aspect: PWP - Alternative A plus Huntington & Mountain View & Devil's Gate Area**

Estimate Type: Planning Level

Estimated Annual Segment Yield = 1840 AFY

**Capital Costs**

Item	Size	Units	Quantity	Unit	Unit Cost	Total Cost	Notes
Alt A Pipe - 4"	4	IN	6,691	LF	\$ 10.00	\$ 268,000	
Alt A Pipe - 8"	16	IN	5,026	LF	\$ 10.00	\$ 804,000	
Alt A Pipe - 12"	20	IN	14,932	LF	\$ 10.00	\$ 2,986,000	
Segment 2 Pipe	16	IN	23,700	LF	\$ 10.00	\$ 3,792,000	
Segment 8 Pipe	4	IN	23,000	LF	\$ 10.00	\$ 920,000	
Segment 3 Pipe	8	IN	8,600	LF	\$ 10.00	\$ 688,000	
Segment 4 & 5A Pipe	8	IN	14,000	LF	\$ 10.00	\$ 1,120,000	
VWC Demand Pipe	8	IN	4,000	LF	\$ 10.00	\$ 320,000	
Pipe Crossings						\$ 300,000	
Pressure Reducing Stations			2	EA	\$ 200,000	\$ 400,000	
Additional Pumping Capacity @ LAGWRP						\$ 200,000	4,500 gpm
Storage Tank @ Scholl Canyon Landfill			2,800,000	GAL	\$1.00	\$ 2,800,000	
Customer Connections						\$ 800,000	
<b>RAW CONSTRUCTION COST</b>						<b>\$ 15,398,000</b>	

**O&M Costs**

Item	Size	Units	Quantity	Unit	Unit Cost	Total Cost	Notes
PWP to GWP for RW System O&M			1840	AFY	\$ 92	\$ 169,280	
PWP to GWP for RW Pumping			1840	AFY	\$ 130	\$ 239,200	
Pipes					\$ 10,898,000	LS 1%	\$ 109,000
Pipe Crossings					\$ 300,000	LS 1%	\$ 3,000
Pressure Reducing Stations					\$ 400,000	LS 1%	\$ 4,000
Storage Tank @ Scholl Canyon Landfill					\$ 2,800,000	LS 1%	\$ 28,000
Recycled Water Purchase			1840	AFY	\$ 31	\$ 57,040	
<b>O&amp;M COST</b>						<b>\$ 609,520</b>	



**Project: CeLAC Regional Water Recycling Project**

**Aspect: GWR - Arroyo Seco Spreading Grounds**

Estimate Type: Planning Level	<b>Estimated Annual Segment Yield = 3450 AFY</b>
-------------------------------	--

**Capital Costs**

Item	Size	Units	Quantity	Unit	Unit Cost	Total Cost	Notes
Pipe	12	IN	3,000	LF	\$ 10.00	\$ 360,000	
LAGWRP Advanced Treatment Upgrade	5	MGD	1	LS	\$ 69,030,000	\$ 17,257,500	Lump sum cost was for 20 MGD from LA RWMP
Recharge Basin Modifications	6	AC	29,040	CY	\$ 5.00	\$ 871,000	Number of acres to be modified used to calculate CY
Alt A Pipe - 4"	4	IN	6,691	LF	\$ 10.00	\$ 268,000	
Alt A Pipe - 8"	16	IN	5,026	LF	\$ 10.00	\$ 804,000	
Alt A Pipe - 12"	20	IN	14,932	LF	\$ 10.00	\$ 2,986,000	
Segment 2 Pipe	16	IN	23,713	LF	\$ 10.00	\$ 3,794,000	
Segment 3 Pipe	8	IN	8,623	LF	\$ 10.00	\$ 690,000	
Segment 4 & 5A Pipe	8	IN	14,000	LF	\$ 10.00	\$ 1,120,000	
VVC Demand Pipe	8	IN	4,000	LF	\$ 10.00	\$ 320,000	
Pipe Crossings						\$ 300,000	
Pressure Reducing Stations			2	EA	\$ 200,000	\$ 400,000	
Additional Pumping Capacity @ LAGWRP						\$ 200,000	4,500 gpm;
Storage Tank @ Scholl Canyon Landfill			2,800,000	GAL	\$1.00	\$ 2,800,000	
Customer Connections						\$ 400,000	
<b>RAW CONSTRUCTION COST</b>						<b>\$ 32,570,500</b>	

\$ 15,313,000

**O&M Costs**

Item	Size	Units	Quantity	Unit	Unit Cost	Total Cost	Notes
LAGWRP Advanced Treatment			651	MG	\$ 1,300	\$ 847,000	
Recharge Basin Maintenance			6	AC	\$ 10,000	\$ 60,000	
Groundwater Extraction - Pumping	1,600	AFY	873,900	kWh	\$ 0.15	\$ 131,100	400 foot head; 75% efficiency
PWP to GWP for RW System O&M			3450	AFY	\$ 92	\$ 317,400	
PWP to GWP for RW Pumping			3450	AFY	\$ 130	\$ 448,500	
Pipes					\$ 9,982,000	LS 1%	\$ 99,800
Pipe Crossings					\$ 300,000	LS 1%	\$ 3,000
Pressure Reducing Stations					\$ 400,000	LS 1%	\$ 4,000
Storage Tank @ Scholl Canyon Landfill					\$ 2,800,000	LS 1%	\$ 28,000
Recycled Water Purchase			3450	AFY	\$ 31	\$ 106,950	

**O&M COST \$ 2,045,750**

\$ 1,198,750





**Project: CeLAC Regional Water Recycling Project**

**Aspect: GWR - Eaton Canyon Spreading Grounds via Fair Oaks Drain**

Estimate Type: Planning Level      Estimated Annual Segment Yield =      **4810**      **AFY**

**Capital Costs**

Item	Size	Units	Quantity	Unit	Unit Cost	Total Cost	Notes
LAGWRP Advanced Treatment Upgrade	7	MGD	1	LS	\$ 69,030,000	\$ 24,160,500	Lump sum cost was for 20 MGD from LA RWMP
Recharge Basin Modifications	5	AC	24,200	CY	\$ 5.00	\$ 605,000	Number of acres to be modified used to calculate CY
Alt A Pipe - 4"	4	IN	6,691	LF	\$ 10.00	\$ 268,000	
Alt A Pipe - 8"	16	IN	5,026	LF	\$ 10.00	\$ 804,000	
Alt A Pipe - 12"	20	IN	14,932	LF	\$ 10.00	\$ 2,986,000	
Segment 2 Pipe	16	IN	23,713	LF	\$ 10.00	\$ 3,794,000	
Segment 3 Pipe (8" w/o #5; 16" w/o GWR)	24	IN	8,623	LF	\$ 10.00	\$ 2,069,000	
Segment 5B Pipe (12" w/o GWR)	24	IN	14,000	LF	\$ 10.00	\$ 3,360,000	
5B to Fair Oaks Drain	24	IN	4,000	LF	\$ 10.00	\$ 960,000	from Altadena G.C. to New York Dr. & N. Allen Ave
Fair Oaks Drain				LF			
Pipe Crossings			76,985			\$ 300,000	
Pressure Reducing Stations			2	EA	\$ 200,000	\$ 400,000	
Additional Pumping Capacity @ LAGWRP						\$ 200,000	4,500 gpm
Storage Tank @ Scholl Canyon Landfill			2,800,000	GAL	\$1.00	\$ 2,800,000	
Customer Connections						\$ 400,000	
<b>RAW CONSTRUCTION COST</b>						<b>\$ 43,106,500</b>	
						\$ 18,946,000	

**O&M Costs**

Item	Size	Units	Quantity	Unit	Unit Cost	Total Cost	Notes
LAGWRP Advanced Treatment			977	MG	\$ 1,300	\$ 1,270,000	
Recharge Basin Maintenance			5	AC	\$ 10,000	\$ 50,000	
Groundwater Extraction - Pumping	3,000	AFY	1,638,600	kWh	\$ 0.15	\$ 245,800	400 foot head; 75% efficiency
PWP to GWP for RW System O&M			4810	AFY	\$ 92	\$ 442,520	
PWP to GWP for RW Pumping			4810	AFY	\$ 130	\$ 625,300	
Pipes			\$ 14,241,000	LS	1%	\$ 142,400	
Pipe Crossings			\$ 300,000	LS	1%	\$ 3,000	
Pressure Reducing Stations			\$ 400,000	LS	1%	\$ 4,000	
Storage Tank @ Scholl Canyon Landfill			\$ 2,800,000	LS	1%	\$ 28,000	
Recycled Water Purchase			4810	AFY	\$ 31	\$ 149,110	
<b>O&amp;M COST</b>						<b>\$ 2,960,130</b>	
						\$ 1,690,130	



**Project: CeLAC Regional Water Recycling Project**

**Aspect: GWR - Eaton Wash Spreading Grounds via Huntington**

Estimate Type: Planning Level      Estimated Annual Segment Yield = 4730      AFY

**Capital Costs**

Item	Size	Units	Quantity	Unit	Unit Cost	Total Cost	Notes
LAGWRP Advanced Treatment Upgrade	7	MGD	1	LS	\$ 69,030,000	\$ 24,160,500	Lump sum cost was for 20 MGD from LA RWMP
Recharge Basin Modifications	5	AC	24,200	CY	\$ 5.00	\$ 605,000	Number of acres to be modified used to calculate CY
Alt A Pipe - 4"	4	IN	6,691	LF	\$ 10.00	\$ 268,000	
Alt A Pipe - 8"	24	IN	5,026	LF	\$ 10.00	\$ 1,206,000	
Alt A Pipe - 12"	24	IN	14,932	LF	\$ 10.00	\$ 3,584,000	
Segment 2 Pipe (16" w/o GWR)	24	IN	23,713	LF	\$ 10.00	\$ 5,691,000	
Segment 6 Pipe (16" w/o GWR)	24	IN	22,000	LF	\$ 10.00	\$ 5,280,000	
Segment 6 Pipe - 12"	12	IN	12,000	LF	\$ 10.00	\$ 1,440,000	
Segment 6 Pipe - 8"	8	IN	4,000	LF	\$ 10.00	\$ 320,000	
Pipe Crossings						\$ 300,000	
Pressure Reducing Stations			2	EA	\$ 200,000	\$ 400,000	
Additional Pumping Capacity @ LAGWRP						\$ 200,000	4,500 gpm;
Storage Tank @ Scholl Canyon Landfill			2,800,000	GAL	\$1.00	\$ 2,800,000	
Customer Connections						\$ 400,000	
<b>RAW CONSTRUCTION COST</b>						<b>\$ 46,654,500</b>	
						\$ 22,494,000	

**O&M Costs**

Item	Size	Units	Quantity	Unit	Unit Cost	Total Cost	Notes
LAGWRP Advanced Treatment			977	MG	\$ 1,300	\$ 1,270,000	
Recharge Basin Maintenance			5	AC	\$ 10,000	\$ 50,000	
Groundwater Extraction - Pumping	3,000	AFY	1,638,600	kWh	\$ 0.15	\$ 245,800	400 foot head; 75% efficiency
PWP to GWP for RW System O&M			4730	AFY	\$ 92	\$ 435,160	
PWP to GWP for RW Pumping			4730	AFY	\$ 130	\$ 614,900	
Pipes			\$ 17,789,000	LS	1%	\$ 177,900	
Pipe Crossings			\$ 300,000	LS	1%	\$ 3,000	
Pressure Reducing Stations			\$ 400,000	LS	1%	\$ 4,000	
Storage Tank @ Scholl Canyon Landfill			\$ 2,800,000	LS	1%	\$ 28,000	
Recycled Water Purchase			4730	AFY	\$ 31	\$ 146,630	
<b>O&amp;M COST</b>						<b>\$ 2,975,390</b>	
						\$ 1,705,390	



**Project: CeLAC Regional Water Recycling Project**  
**Aspect: GWR - Arroyo Seco & Eaton Wash Spreaing Grounds**

Estimate Type: Planning Level	<b>Estimated Annual Segment Yield = 6620 AFY</b>
-------------------------------	--

**Capital Costs**

Item	Size	Units	Quantity	Unit	Unit Cost	Total Cost	Notes
Pipe	12	IN	3,000	LF	\$ 10.00	\$ 360,000	
LAGWRP Advanced Treatment Upgrade	12	MGD	1	LS	\$ 69,030,000	\$ 41,418,000	Lump sum cost was for 20 MGD from LA RWMP
Recharge Basin Modifications	11	AC	53,240	CY	\$ 5.00	\$ 2,928,000	Number of acres to be modified used to calculate CY
Alt A Pipe - 4"	4	IN	6,691	LF	\$ 10.00	\$ 268,000	
Alt A Pipe - 8"	16	IN	5,026	LF	\$ 10.00	\$ 804,000	
Alt A Pipe - 12"	24	IN	14,932	LF	\$ 10.00	\$ 3,584,000	
Segment 2 Pipe	16	IN	23,713	LF	\$ 10.00	\$ 3,794,000	
Segment 3 Pipe (8" w/o #5; 16" w/o GWR)	24	IN	8,623	LF	\$ 10.00	\$ 2,069,000	
Segment 4 & 5A Pipe	8	IN	14,000	LF	\$ 10.00	\$ 1,120,000	
Segment 5B Pipe (12" w/o GWR)	24	IN	14,000	LF	\$ 10.00	\$ 3,360,000	
5B to Fair Oaks Drain	24	IN	4,000	LF	\$ 10.00	\$ 960,000	from Altadena G.C. to New York Dr. & N. Allen Ave
Fair Oaks Drain			12,000	LF			
VVC Demand Pipe	8	IN	4,000	LF	\$ 10.00	\$ 320,000	
Pipe Crossings						\$ 300,000	
Pressure Reducing Stations			2	EA	\$ 200,000	\$ 400,000	
Additional Pumping Capacity @ LAGWRP						\$ 200,000	4,500 gpm;
Storage Tank @ Scholl Canyon Landfill			2,800,000	GAL	\$1.00	\$ 2,800,000	
Customer Connnections						\$ 400,000	
<b>RAW CONSTRUCTION COST</b>						<b>\$ 65,085,000</b>	
						\$ 23,667,000	

**O&M Costs**

Item	Size	Units	Quantity	Unit	Unit Cost	Total Cost	Notes
LAGWRP Advanced Treatment			1,629	MG	\$ 1,300	\$ 2,117,000	
Recharge Basin Maintenance			11	AC	\$ 10,000	\$ 110,000	
Groundwater Extraction - Pumping	4,600	AFY	2,512,500	kWh	\$ 0.15	\$ 376,900	400 foot head; 75% efficiency
PWP to GWP for RW System O&M			6620	AFY	\$ 92	\$ 609,040	
PWP to GWP for RW Pumping			6620	AFY	\$ 130	\$ 860,600	
Pipes				LS	1%	\$ 162,800	
Pipe Crossings				LS	1%	\$ 3,000	
Pressure Reducing Stations				LS	1%	\$ 4,000	
Storage Tank @ Scholl Canyon Landfill				LS	1%	\$ 28,000	
Recycled Water Purchase			6620	AFY	\$ 31	\$ 205,220	
<b>O&amp;M COST</b>						<b>\$ 4,476,560</b>	
						\$ 2,359,560	

**Project: CeLAC Regional Water Recycling Project**
**Aspect: GWR - Arroyo Seco & Eaton Wash - with Recycled Water & Stormwater**

Estimate Type: Planning Level	<b>Estimated Annual Segment Yield =</b>	<b>10,270</b>	<b>AFY</b>
-------------------------------	---	---------------	------------

**Capital Costs**

Item	Size	Units	Quantity	Unit	Unit Cost	Total Cost	Notes
Pipe	12	IN	3,000	LF	\$ 10.00	\$ 360,000	
LAGWRP Advanced Treatment Upgrade	12	MGD	1	LS	\$ 69,030,000	\$ 41,418,000	Lump sum cost was for 20 MGD from LA RWMP
Recharge Basin Modifications	11	AC	53,240	CY	\$ 5.00	\$ 2,928,000	Number of acres to be modified used to calculate CY
Devil's Gate Modifications			1	LS	\$ 1,000,000	\$ 1,000,000	Based LACFCD, 1997 + 100%
Alt A Pipe - 4"	4	IN	6,691	LF	\$ 10.00	\$ 268,000	
Alt A Pipe - 8"	16	IN	5,026	LF	\$ 10.00	\$ 804,000	
Alt A Pipe - 12"	24	IN	14,932	LF	\$ 10.00	\$ 3,584,000	
Segment 2 Pipe	16	IN	23,713	LF	\$ 10.00	\$ 3,794,000	
Segment 3 Pipe (8" w/o GWR)	42	IN	8,623	LF	\$ 10.00	\$ 3,622,000	
Segment 4 & 5A Pipe	8	IN	14,000	LF	\$ 10.00	\$ 1,120,000	
Segment 5B Pipe (12" w/o GWR)	42	IN	14,000	LF	\$ 10.00	\$ 5,880,000	
5B to Fair Oaks Drain	42	IN	4,000	LF	\$ 10.00	\$ 1,680,000	from Altadena G.C. to New York Dr. & N. Allen Ave
Fair Oaks Drain			12,000	LF			
VWC Demand Pipe	8	IN	4,000	LF	\$ 10.00	\$ 320,000	
Pipe Crossings						\$ 300,000	
Pressure Reducing Stations			2	EA	\$ 200,000	\$ 400,000	
Additional Pumping Capacity @ LAGWRP						\$ 200,000	4,500 gpm;
Storage Tank @ Scholl Canyon Landfill			2,800,000	GAL	\$1.00	\$ 2,800,000	
Customer Connections						\$ 400,000	
<b>RAW CONSTRUCTION COST</b>						<b>\$ 70,878,000</b>	
						\$ 29,460,000	

**O&M Costs**

Item	Size	Units	Quantity	Unit	Unit Cost	Total Cost	Notes
LAGWRP Advanced Treatment			1,629	MG	\$ 1,300	\$ 2,117,000	
Recharge Basin Maintenance			11	AC	\$ 10,000	\$ 110,000	
Groundwater Extraction - Pumping	8,160	AFY	4,456,900	kWh	\$ 0.15	\$ 668,500	400 foot head; 75% efficiency
PWP to GWP for RW System O&M			10270	AFY	\$ 92	\$ 944,840	
PWP to GWP for RW Pumping			10270	AFY	\$ 130	\$ 1,335,100	
Pipes						\$ 21,072,000	
Pipe Crossings						\$ 300,000	
Pressure Reducing Stations						\$ 400,000	
Storage Tank @ Scholl Canyon Landfill						\$ 2,800,000	
Recycled Water Purchase			10270	AFY	\$ 31	\$ 318,370	
<b>O&amp;M COST</b>						<b>\$ 5,739,510</b>	
						\$ 3,622,510	

## **Appendix B**

-

### **Summary of Recycled Water Studies by CVWD, GWP, LADWP, and PWP**

# Memorandum



---

## Central Los Angeles County Regional Water Recycling Project

**Subject:** Summary of Recent Recycled Water Studies

**Prepared by:** Rob Morrow

**Reviewed by:** Tom Richardson

**Date:** July 2007

---

Glendale Water and Power (GWP), Los Angeles Department of Water and Power (LADWP), Pasadena Water and Power (PWP) and Crescenta Valley Water District (CVWD) recently completing recycled water planning studies to expand the beneficial use of recycled water produced from Los Angeles-Glendale Water Reclamation Plant (LAGWRP). These studies include:

- *CVWD Recycled Water Feasibility Study*. Bookman-Edmonston (BE), April 2004. CVWD Project E-725.
- *Los Angeles (LA) Recycled Water Master Plan (RWMP)*. CH2MHILL and CDM (CH:CDM), December 2006.
- *Glendale Water Supply Evaluation for Downtown Specific Plan*. GWP, August 2006.
- *PWP Recycled Water Feasibility Study (RWFS) – Final Report*. MWH, May 2005.

In addition, LADWP and PWP included an evaluation of groundwater recharge (GWR) opportunities with recycled water in their respective recycled water studies and CVWD completed a GWR study as well (Geomatrix, 2005).

Each study found significant recycled water use opportunities as well as obstacles to maximize the beneficial use of recycled water from LAGWRP. The primary obstacles were the cost of recycle water projects and use of the water during the low demand period of the winter. The studies had the following primary recommendations:

- GWP should continue recycled water system expansion opportunities if outside funding is available to improve cost-effectiveness
- GWP should connect existing dual-plumbing demands and expand dual-plumbing opportunities
- LADWP should expand use of recycled water based on tiered users identified in the RWMP
- LADWP should not conduct GWR with recycled water from LAGWRP but rather from LADWP's larger and better situated Tillman Water Reclamation Plant (WRP)
- PWP has extensive non-potable demands but requires outside funding to create economically viable projects
- PWP has opportunities to significantly expand groundwater recharge in the Raymond Basin at existing facilities and could add recycled water depending upon the results of subsequent investigations
- CVWD has limited non-potable demands and serving these demands with recycled water is not economically feasible at this time even with outside funding
- CVWD has groundwater recharge opportunities in the Verdugo Basin but the governance structure is not in place to receive groundwater production credit

## **Appendix C**

-

### **LA IRWMP Project Database Information for CeLAC RWRP Phase 1**

# 1.) Lead Implementing Agency/Organization Information (Red boxes indicate required fields)

Please provide the following information regarding the project sponsor and proposed project.

**Implementing Agency / Organization / Individual :**

Glendale Water and Pov

**Agency / Organization / Individual Address(250 characters):**

Glendale Water & Power, Los Angeles Department of Water & Power, Pasadena Water & Power

**Possible Partnering Agencies / Land Managers(250 characters):**

**First Name:**

Rosanna

**Last Name:**

Lau

**Title:**

**Telephone:**

818-548-3966

(ex. '999-123-1234')

**Fax:**

818-240-4754

(ex. '999-123-1234')

**E-mail:**

rlau@ci.glendale.ca.us

**Website:**

www.glendalewaterandp

**Project Title:**

PHASE 1 - Central Los A

**Project Sub-region (supply up to three):**



Upper Los Angeles River
Upper San Gabriel River
Rio Hondo

**Either the latitude/longitude or a location description is required. To determine the latitude/longitude, use the closest address or intersection. If the project is linear, use the furthest upstream latitude/longitude.**

**Project Latitude:** [Find Lat/Long](#)

 (ex. '34.047555')

**Project Longitude:**

 (ex. '-118.445033')

**Location Description (250 characters):**

**Project Cooperating Agency(ies)/Organization(s)/Individual(s):**

Los Angeles Water and I
Glendale Water and Pov
Pasadena Water and Po
Foothill Municipal Water

**Project Status:**

New
-----

## 2.) Project Need

**It is important to understand the need(s) or issue(s) that the proposed project will address and the benefits that it will provide . Information provided in this section defines the need(s) or issue(s) that the proposed project will address and will help to catalog existing need(s) or issue(s) in the Greater Los Angeles County Region.**

**Please provide a 1 -2 paragraph description of the need(s) or problem(s) that the project will address. As applicable, discuss the water quality / flood management need, water supply need, or beneficial use (e.g. habitat, open space, and/or recreation) need. Discuss critical impacts that will occur if the proposal is not implemented. (1024 characters maximum)**

The LAGWRP produces over 17,000 afy of tertiary treated water for use by GWP, LADWP and PWP. Currently, less than 4,000 afy is beneficially used to meet non-potable water demands. The project was developed to maximize the beneficial uses of an additional 13,000 afy of recycled water. Key project needs include:

- Regional Coordination - Need to coordinate non-potable and GWR opportunities for greater benefit of project partners
- Water Supply Reliability - Need to replace imported water use with recycled water
- Water Recycling - Need to maximize beneficial use of tertiary water from LAGWRP.
- Wastewater Management - Need to reduce wastewater flow to Hyperion WWTP
- Stormwater Management - Need to support stormwater management initiatives in Arroyo Seco and Eaton Wash.
- LA River Water Quality - Need to improve LA River effluent quality (for metals based on CTR)
- Groundwater Quality - Need to offset recharge of high salinity waters in the Raymond Basin

### 3.) Project Description (Red boxes indicate required fields)

A general description of the proposed project is needed. This section will provide information associated with the project concept, general project information, and readiness to proceed. It is recognized that much of the requested information may not be available for projects that are at a conceptual level of project development. We appreciate and need your ideas.

Please provide a 1 – 2 paragraph description of the project including the general project concept, what will be constructed/implemented, how the constructed project will function, and treatment methods, as appropriate. (1024 characters maximum)

The project has identified uses for approximately 17,000 afy of recycled water from the LAGRWP (compared to existing use of 4,000 afy) over 3 phases. The phases are roughly based around five year planning segments such that Phase 1 includes projects that can be on-line in five years or less (by 2012), Phase 2 by 2017, and Phase 3 by 2022.

In total, the project increases beneficial use of recycled water from less than 25% (4,000 afy) of LAGWRP production capacity to over 80% (17,000 afy). Phase 1 includes 450 afy, 2,120 afy and 730 afy of non-potable demands for GWP, LADWP and PWP, respectively. All recycled water will replace the use of imported water from MWD.

If applicable, supply up to three watershed / surface water bodies or groundwater basins associated with the proposed project.

- 
- 
- 

Please identify up to three available documents which contain information specific to the proposed project. (Project Sources)

- 
- 
-

<b>Please indicate the primary objective and secondary objectives for proposed project. (Check all that apply)</b>			
<b>Water Quality Objectives</b>			
<input type="radio"/> Primary	<input type="radio"/> Secondary	<input checked="" type="radio"/> NA	Storm water or urban runoff water quality improvement
<input type="radio"/> Primary	<input type="radio"/> Secondary	<input checked="" type="radio"/> NA	Wastewater effluent water quality improvement
<input type="radio"/> Primary	<input checked="" type="radio"/> Secondary	<input type="radio"/> NA	Receiving water body quality improvement
<input type="radio"/> Primary	<input type="radio"/> Secondary	<input checked="" type="radio"/> NA	Improved flood management
<input type="radio"/> Primary	<input type="radio"/> Secondary	<input checked="" type="radio"/> NA	Ground water protection or improvement
<input type="radio"/> Primary	<input type="radio"/> Secondary	<input checked="" type="radio"/> NA	Other (Please State): <input type="text"/>
<b>Water Supply Objectives</b>			
<input checked="" type="radio"/> Primary	<input type="radio"/> Secondary	<input type="radio"/> NA	Reduced reliance on imported water
<input checked="" type="radio"/> Primary	<input type="radio"/> Secondary	<input type="radio"/> NA	Increased water supply reliability
<input type="radio"/> Primary	<input checked="" type="radio"/> Secondary	<input type="radio"/> NA	Increased operational flexibility
<input type="radio"/> Primary	<input type="radio"/> Secondary	<input checked="" type="radio"/> NA	Increased water conservation or water use efficiency
<input checked="" type="radio"/> Primary	<input type="radio"/> Secondary	<input type="radio"/> NA	Increased water reclamation or recycling
<input type="radio"/> Primary	<input type="radio"/> Secondary	<input checked="" type="radio"/> NA	Increased groundwater recharge, recovery and management
<input type="radio"/> Primary	<input type="radio"/> Secondary	<input checked="" type="radio"/> NA	Reduced sea water intrusion
<input type="radio"/> Primary	<input type="radio"/> Secondary	<input checked="" type="radio"/> NA	Protect/improve drinking water standards
<input type="radio"/> Primary	<input type="radio"/> Secondary	<input checked="" type="radio"/> NA	Other (Please State): <input type="text"/>
<b>Beneficial Use (e.g. habitat, open space, recreation) Objectives</b>			
<input type="radio"/> Primary	<input type="radio"/> Secondary	<input checked="" type="radio"/> NA	Creation or enhancement of wetlands (non-treatment)
<input type="radio"/> Primary	<input type="radio"/> Secondary	<input checked="" type="radio"/> NA	Restoration and protection of habitat (Upland, Riparian, Aquatic, and Wetland)
<input type="radio"/> Primary	<input type="radio"/> Secondary	<input checked="" type="radio"/> NA	Creation or enhancement of public access, recreation, or open space



Is the proposed project an element or phase of a regional or larger program?	<input checked="" type="checkbox"/> Yes
If yes, please identify the program. (Project Integration)	Central Los Angeles Co

Proposed Construction/Implementation Start Date (mm/dd/yyyy):	Proposed Construction/Implementation Complete Date (mm/dd/yyyy):
1/1/2010	1/1/2012
Ready For Construction Bid:	1-3 Years

Item	Status	Date
Conceptual Plans	Complete	8/1/2007 (mm/dd/yyyy)
Land Acquisition/Easement	Complete	1/1/2007 (mm/dd/yyyy)
Preliminary Plans	In process	7/1/2008 (mm/dd/yyyy)
CEQA/NEPA	In process	7/1/2008 (mm/dd/yyyy)
Permits	Not initiated	(mm/dd/yyyy)
Construction Drawings	Not initiated	(mm/dd/yyyy)
Funding	Not initiated	(mm/dd/yyyy)

For projects that do not include construction, please briefly describe the project readiness-to-proceed. (1024 characters maximum)

#### 4) Project Benefits (Red boxes indicate required fields)

Describe the benefits that the project will accomplish. Please provide input to characterize the benefits of the proposed project. Information provided will be used in the assessment of project benefits.

Please provide a 1 -2 paragraph description of the benefit(s) that the project will address. As applicable, discuss the water quality / flood management benefit, water supply benefit, or beneficial use benefit. (1024 characters maximum)

In total, the project increases beneficial use of recycled water from less than 25% (4,000 afy) of LAGWRP production capacity to over 80% (17,000 afy). Phase 1 includes 450 afy, 2,120 afy and 730 afy of non-potable demands for GWP, LADWP and PWP, respectively.

Other benefits include:

- Provides recycled water to a wide geographic area
- Recycled water is a local, reliable water supply that offsets potable demand.
- Reduces wastewater flow to Hyperion WWTP

Please select the dominant existing land use type for the proposed project location.

Public

Please select the dominant land use type for areas upstream and downstream of the proposed project location.

Public

Does the project address any known environmental justice issues?

Not Sure

Is the project located within or adjacent to a disadvantaged community?

Not Sure

Does the project include disadvantaged community participation?

Not Sure

If yes, please identify the group or organization



Please provide the following project benefit information for all applicable components of the proposed project. Benefit categories include water quality / flood management, water supply, and beneficial use. **PLEASE ATTEMPT TO SUPPLY ALL INFORMATION RELEVANT TO YOUR PROJECT. THIS INFORMATION WILL BE USED TO ANALYSE AND ASSESS PROJECTS FOR FUTURE FUNDING.**

### WATER QUALITY / FLOOD MANAGEMENT BENEFITS

Project information provided will IRWMP to access water quality /flood management benefits to stormwater runoff, wastewater effluent, and receiving waterbody. If surface water detention and groundwater recharge are an additional project benefit, please provide information in the Water Supply Benefit section following.

Water Quality Benefit Information	
Treatment technologies	<input type="text"/>
Design operational treatment capacity (Million gal. / day)	<input type="text"/>
Targeted Contaminants (Check all that apply)	
<input type="checkbox"/> Metal	<input type="checkbox"/> Pathogens
<input type="checkbox"/> Nutrients	<input type="checkbox"/> Organic Pollutants (eg., pesticides)
	<input type="checkbox"/> Trash
	<input type="checkbox"/> Other (describe)
Description (Water Quality Desc)	<input type="text"/>

Flood Management Benefit Information	
Maximum volume of temporary storage of storm runoff (acre-feet)	<input type="text"/>
Maximum increased conveyance capacity (cubic feet / second)	<input type="text"/>
Estimated area benefiting from flood damage reduction (acres)	<input type="text"/>
Estimated level of flood protection resulting from project implementation.	<input type="text" value="Not Available"/>
Other	<input type="text" value="0"/>
Estimated annual value of flood damage reduction provided by project (\$ / Year)	<input type="text"/>
Acres required for project implementation	<input type="text"/>

### WATER SUPPLY BENEFITS

Project information provided will help to quantify water supply benefits from enhanced local water supply or reduced potable water demand.

Enhanced Water Supply or Demand Reduction Benefit Information	
<b>Source of increased supply or demand reduction</b>	
<input type="checkbox"/> Groundwater <input checked="" type="checkbox"/> Recycled water <input type="checkbox"/> Transfer	<input type="checkbox"/> Groundwater treatment <input type="checkbox"/> Conservation/water use efficiency <input type="checkbox"/> Other (Describe) <input type="text"/>
<input type="checkbox"/> Increased surface water storage <input type="checkbox"/> Ocean desalination	
<b>Type of enhanced supply or demand reduction</b>	Non-Potable <input type="text"/>
<b>Description (Water Supply Description)</b> <input type="text"/>	
<b>Annual yield of supply (acre-feet/year)</b>	3300 <input type="text"/>
<b>Availability by water-year type</b>	
Average Year – Between 10 and 25 inches of rainfall (acre-feet / year)	3300 <input type="text"/>
Dry Year – Less than 10 inches rainfall (acre-feet / year)	3300 <input type="text"/>
Wet Year – Greater than 25 inches rainfall (acre-feet / year)	3300 <input type="text"/>
Other Water Year (acre-feet / year)	3300 <input type="text"/>
	<b>Description</b> 3300 <input type="text"/>
<b>Availability by season (check all that apply)</b>	
<input checked="" type="checkbox"/> Summer <input checked="" type="checkbox"/> Fall	<input checked="" type="checkbox"/> Spring <input checked="" type="checkbox"/> Winter
<b>Does the project have the potential to displace demands on the Bay/Delta/Estuary system?</b>	Yes <input type="text"/>

For projects that include detention and groundwater recharge, please complete the following:	
<b>How many acres of land drain into this detention basin approximately? (acres)</b>	<input type="text"/>
<b>Detention basin area (acres)</b>	<input type="text"/>
<b>Detention basin max. operational depth (ft.)</b>	<input type="text"/>
<b>% of basin covered by wetlands</b>	0 <input type="text"/>
<b>Soil type (based on Unified Soil Classification System)</b>	Not Available <input type="text"/>
<b>If other than infiltration, identify method (e.g. injection) and recharge (acre-feet / year)</b>	<input type="text"/>
<b>Estimated basin annual inflow (acre-feet / year)</b>	<input type="text"/>
<b>Estimated basin annual outflow (acre-feet / year)</b>	<input type="text"/>

### BENEFICIAL USE BENEFITS

Project information provided will help to quantify the benefits associated with projects that create or expand beneficial uses.

Beneficial Use Benefit	
Non-treatment wetland area (acres)	0
Treatment wetland area (acres)	0
Riparian habitat area (acres)	0
Non-developed open space area (acres)	0
<b>Multiple use / recreation area (acres) – additionally, select the type of multiple use / recreation and associated acres by type</b> Single Sport Athletics                      0 Multiple Sport Athletics Acres            0 Other Recreation Acres                      0 Pedestrian Trail Acres                        0 Equestrian Trail Acres                        0 Other Passive Activity                        0 Other Acres (describe)                       0 Descpition (Public Access, Open Space, Habitat, Recreation)	
<b>Total Project area (acres)</b>	0

## 5.) Project Cost Estimate

Project cost information is needed to assist in comparing benefits and cost. Additionally, knowledge of the project type and cost will assist in identifying funding sources for potential projects.

Please indicate the estimated total capital cost for project implementation. These costs include land purchase/easement, planning/design/engineering, construction/implementation, environmental compliance, administration, and contingency.

Lower Estimated total capital cost (\$)	40000000
Upper Estimated total capital cost (\$)	45000000
Of the total capital cost, please indicate the estimated cost for land purchase / easement (\$)	100000
Annual Operation and Maintenance Cost (\$)	1000000
Design Life of Project Years (years)	30

## **Appendix D**

-

### **LA IRWMP Project Database Information for Full CeLAC RWRP**

# 1.) Lead Implementing Agency/Organization Information (Red boxes indicate required fields)

Please provide the following information regarding the project sponsor and proposed project.

**Implementing Agency / Organization / Individual :**

Glendale Water and Pov

**Agency / Organization / Individual Address(250 characters):**

141 N. Glendale Ave., 4th Floor  
Glendale, CA 91206

**Possible Partnering Agencies / Land Managers(250 characters):**

Glendale Water & Power; Los Angeles Department of Water & Power; Pasadena Water & Power; Foothill Municipal Water District

**First Name:**

Rosanna

**Last Name:**

Lau

**Title:**

**Telephone:**

818-548-3966 (ex. '999-123-1234')

**Fax:**

818-240-4754 (ex. '999-123-1234')

**E-mail:**

rlau@ci.glendale.ca.us

**Website:**

www.glendalewaterandp

**Project Title:**

Central Los Angeles Cot

**Project Sub-region (supply up to three):**

Upper Los Angeles River
Upper San Gabriel River
Rio Hondo

**Either the latitude/longitude or a location description is required. To determine the latitude/longitude, use the closest address or intersection. If the project is linear, use the furthest upstream latitude/longitude.**

**Project Latitude:** [Find Lat/Long](#)

 (ex. '34.047555')

**Project Longitude:**

 (ex. '-118.445033')

**Location Description (250 characters):**

**Project Cooperating Agency(ies)/Organization(s)/Individual(s):**

Los Angeles Water and I
Glendale Water and Pov
Pasadena Water and Po
Foothill Municipal Water

**Project Status:**

New
-----



## 2.) Project Need

**It is important to understand the need(s) or issue(s) that the proposed project will address and the benefits that it will provide . Information provided in this section defines the need(s) or issue(s) that the proposed project will address and will help to catalog existing need(s) or issue(s) in the Greater Los Angeles County Region.**

**Please provide a 1 -2 paragraph description of the need(s) or problem(s) that the project will address. As applicable, discuss the water quality / flood management need, water supply need, or beneficial use (e.g. habitat, open space, and/or recreation) need. Discuss critical impacts that will occur if the proposal is not implemented. (1024 characters maximum)**

The LAGWRP produces over 17,000 afy of tertiary treated water for use by GWP, LADWP and PWP. Currently, less than 4,000 afy is beneficially used to meet non-potable water demands. The project was developed to maximize the beneficial uses of an additional 13,000 afy of recycled water. Key project needs include:

- Regional Coordination - Need to coordinate non-potable and GWR opportunities for greater benefit of project partners
- Water Supply Reliability - Need to replace imported water use with recycled water
- Water Recycling - Need to maximize beneficial use of tertiary water from LAGWRP.
- Wastewater Management - Need to reduce wastewater flow to Hyperion WWTP
- Stormwater Management - Need to support stormwater management initiatives in Arroyo Seco and Eaton Wash.
- LA River Water Quality - Need to improve LA River effluent quality (for metals based on CTR)
- Groundwater Quality - Need to offset recharge of high salinity waters in the Raymond Basin

### 3.) Project Description (Red boxes indicate required fields)

A general description of the proposed project is needed. This section will provide information associated with the project concept, general project information, and readiness to proceed. It is recognized that much of the requested information may not be available for projects that are at a conceptual level of project development. We appreciate and need your ideas.

Please provide a 1 – 2 paragraph description of the project including the general project concept, what will be constructed/implemented, how the constructed project will function, and treatment methods, as appropriate. (1024 characters maximum)

The project has identified uses for approximately 17,000 afy of recycled water from the LAGRWP (compared to existing use of 4,000 afy) over 3 phases. The phases are roughly based around five year planning segments such that Phase 1 includes projects that can be on-line in five years or less (by 2012), Phase 2 by 2017, and Phase 3 by 2022.

In total, the project increases beneficial use of recycled water from less than 25% (4,000 afy) of LAGRWP production capacity to over 80% (17,000 afy). Phase 1 includes 450 afy, 2,120 afy and 730 afy of non-potable demands for GWP, LADWP and PWP, respectively. Phase 2 includes 2,000 afy of recycled water groundwater recharge (plus 2,000 afy of blend supply) at Arroyo Seco Spreading Grounds. Phase 3 includes 3,000 afy of recycled water groundwater recharge (plus 3,000 afy of blend supply) at Eaton Wash Spreading Grounds.

All recycled water will replace the use of imported water from MWD.

If applicable, supply up to three watershed / surface water bodies or groundwater basins associated with the proposed project.

Los Angeles River watershed

Raymond Basin

Verdugo Basin

Please identify up to three available documents which contain information specific to the proposed project. (Project Sources)

City of Pasadena Water

City of Los Angeles Rec

CeLAC RWRP Project C

<b>Please indicate the primary objective and secondary objectives for proposed project. (Check all that apply)</b>			
<b>Water Quality Objectives</b>			
<input type="radio"/> Primary	<input checked="" type="radio"/> Secondary	<input type="radio"/> NA	Storm water or urban runoff water quality improvement
<input type="radio"/> Primary	<input checked="" type="radio"/> Secondary	<input type="radio"/> NA	Wastewater effluent water quality improvement
<input type="radio"/> Primary	<input checked="" type="radio"/> Secondary	<input type="radio"/> NA	Receiving water body quality improvement
<input type="radio"/> Primary	<input checked="" type="radio"/> Secondary	<input type="radio"/> NA	Improved flood management
<input checked="" type="radio"/> Primary	<input type="radio"/> Secondary	<input type="radio"/> NA	Ground water protection or improvement
<input type="radio"/> Primary	<input type="radio"/> Secondary	<input checked="" type="radio"/> NA	Other (Please State): <input type="text"/>
<b>Water Supply Objectives</b>			
<input checked="" type="radio"/> Primary	<input type="radio"/> Secondary	<input type="radio"/> NA	Reduced reliance on imported water
<input checked="" type="radio"/> Primary	<input type="radio"/> Secondary	<input type="radio"/> NA	Increased water supply reliability
<input checked="" type="radio"/> Primary	<input type="radio"/> Secondary	<input type="radio"/> NA	Increased operational flexibility
<input type="radio"/> Primary	<input type="radio"/> Secondary	<input checked="" type="radio"/> NA	Increased water conservation or water use efficiency
<input checked="" type="radio"/> Primary	<input type="radio"/> Secondary	<input type="radio"/> NA	Increased water reclamation or recycling
<input checked="" type="radio"/> Primary	<input type="radio"/> Secondary	<input type="radio"/> NA	Increased groundwater recharge, recovery and management
<input type="radio"/> Primary	<input type="radio"/> Secondary	<input checked="" type="radio"/> NA	Reduced sea water intrusion
<input type="radio"/> Primary	<input type="radio"/> Secondary	<input checked="" type="radio"/> NA	Protect/improve drinking water standards
<input type="radio"/> Primary	<input type="radio"/> Secondary	<input checked="" type="radio"/> NA	Other (Please State): <input type="text"/>
<b>Beneficial Use (e.g. habitat, open space, recreation) Objectives</b>			
<input type="radio"/> Primary	<input type="radio"/> Secondary	<input checked="" type="radio"/> NA	Creation or enhancement of wetlands (non-treatment)
<input type="radio"/> Primary	<input checked="" type="radio"/> Secondary	<input type="radio"/> NA	Restoration and protection of habitat (Upland, Riparian, Aquatic, and Wetland)
<input type="radio"/> Primary	<input checked="" type="radio"/> Secondary	<input type="radio"/> NA	Creation or enhancement of public access, recreation, or open space



Is the proposed project an element or phase of a regional or larger program?	<input type="checkbox"/> Yes
If yes, please identify the program. (Project Integration)	

Proposed Construction/Implementation Start Date (mm/dd/yyyy):	Proposed Construction/Implementation Complete Date (mm/dd/yyyy):
1/1/2010	1/1/2022
Ready For Construction Bid:	3-5 Years

Item	Status	Date
Conceptual Plans	Complete	8/1/2007 (mm/dd/yyyy)
Land Acquisition/Easement	In process	1/1/2008 (mm/dd/yyyy)
Preliminary Plans	In process	7/1/2008 (mm/dd/yyyy)
CEQA/NEPA	In process	7/1/2008 (mm/dd/yyyy)
Permits	Not initiated	(mm/dd/yyyy)
Construction Drawings	Not initiated	(mm/dd/yyyy)
Funding	In process	1/1/2008 (mm/dd/yyyy)

For projects that do not include construction, please briefly describe the project readiness-to-proceed. (1024 characters maximum)

#### 4) Project Benefits (Red boxes indicate required fields)

Describe the benefits that the project will accomplish. Please provide input to characterize the benefits of the proposed project. Information provided will be used in the assessment of project benefits.

Please provide a 1 -2 paragraph description of the benefit(s) that the project will address. As applicable, discuss the water quality / flood management benefit, water supply benefit, or beneficial use benefit. (1024 characters maximum)

In total, the project increases beneficial use of recycled water from less than 25% (4,000 afy) of LAGWRP production capacity to over 80% (17,000 afy).

Phase 1 includes 450 afy, 2,120 afy and 730 afy of non-potable demands for GWP, LADWP and PWP, respectively.

Phase 2 includes 2,000 afy of GWR-RW at Arroyo Seco Spreading Grounds. It also includes 200 afy, 680 afy and 1,110 afy of non-potable demands for GWP, LADWP and PWP, respectively.

Phase 3 includes 3,000 afy of GWR-RW at Eaton Wash Spreading Grounds. It also includes 100 afy, 2,600 afy and 170 afy of non-potable

Please select the dominant existing land use type for the proposed project location.

Public

Please select the dominant land use type for areas upstream and downstream of the proposed project location.

Public

Does the project address any known environmental justice issues?

Not Sure

Is the project located within or adjacent to a disadvantaged community?

Not Sure

Does the project include disadvantaged community participation?

Not Sure

If yes, please identify the group or organization

Please provide the following project benefit information for all applicable components of the proposed project. Benefit categories include water quality / flood management, water supply, and beneficial use. **PLEASE ATTEMPT TO SUPPLY ALL INFORMATION RELEVANT TO YOUR PROJECT. THIS INFORMATION WILL BE USED TO ANALYSE AND ASSESS PROJECTS FOR FUTURE FUNDING.**

### WATER QUALITY / FLOOD MANAGEMENT BENEFITS

Project information provided will IRWMP to access water quality /flood management benefits to stormwater runoff, wastewater effluent, and receiving waterbody. If surface water detention and groundwater recharge are an additional project benefit, please provide information in the Water Supply Benefit section following.

Water Quality Benefit Information	
Treatment technologies	MF/RO/UV
Design operational treatment capacity (Million gal. / day)	12
Targeted Contaminants (Check all that apply)	
<input checked="" type="checkbox"/> Metal	<input type="checkbox"/> Pathogens
<input checked="" type="checkbox"/> Nutrients	<input type="checkbox"/> Organic Pollutants (eg., pesticides)
	<input type="checkbox"/> Trash
	<input checked="" type="checkbox"/> Other (describe)
Description (Water Quality Desc)	TDS

Flood Management Benefit Information	
Maximum volume of temporary storage of storm runoff (acre-feet)	
Maximum increased conveyance capacity (cubic feet / second)	
Estimated area benefiting from flood damage reduction (acres)	
Estimated level of flood protection resulting from project implementation.	Not Available
Other	0
Estimated annual value of flood damage reduction provided by project (\$ / Year)	
Acres required for project implementation	34

### WATER SUPPLY BENEFITS

Project information provided will help to quantify water supply benefits from enhanced local water supply or reduced potable water demand.

Enhanced Water Supply or Demand Reduction Benefit Information	
<b>Source of increased supply or demand reduction</b>	
<input checked="" type="checkbox"/> Groundwater <input type="checkbox"/> Groundwater treatment <input type="checkbox"/> Increased surface water storage	
<input checked="" type="checkbox"/> Recycled water <input type="checkbox"/> Conservation/water use efficiency <input type="checkbox"/> Ocean desalination	
<input type="checkbox"/> Transfer <input type="checkbox"/> Other (Describe) <input type="text"/>	
<b>Type of enhanced supply or demand reduction</b>	Other (describe) <input type="text"/>
<b>Description (Water Supply Description)</b>	Both Potable & Non-Potable
<b>Annual yield of supply (acre-feet/year)</b>	13000.000
<b>Availability by water-year type</b>	
Average Year – Between 10 and 25 inches of rainfall (acre-feet / year)	13000.000
Dry Year – Less than 10 inches rainfall (acre-feet / year)	13000.000
Wet Year – Greater than 25 inches rainfall (acre-feet / year)	13000.000
Other Water Year (acre-feet / year)	13000
<b>Description</b>	13000
<b>Availability by season (check all that apply)</b>	
<input checked="" type="checkbox"/> Summer <input checked="" type="checkbox"/> Spring	
<input checked="" type="checkbox"/> Fall <input checked="" type="checkbox"/> Winter	
<b>Does the project have the potential to displace demands on the Bay/Delta/Estuary system?</b>	Yes <input type="text"/>

For projects that include detention and groundwater recharge, please complete the following:	
<b>How many acres of land drain into this detention basin approximately? (acres)</b>	<input type="text"/>
<b>Detention basin area (acres)</b>	34
<b>Detention basin max. operational depth (ft.)</b>	6
<b>% of basin covered by wetlands</b>	0
<b>Soil type (based on Unified Soil Classification System)</b>	Not Available
<b>If other than infiltration, identify method (e.g. injection) and recharge (acre-feet / year)</b>	surface spreading of 10,
<b>Estimated basin annual inflow (acre-feet / year)</b>	5000
<b>Estimated basin annual outflow (acre-feet / year)</b>	0



### BENEFICIAL USE BENEFITS

Project information provided will help to quantify the benefits associated with projects that create or expand beneficial uses.

Beneficial Use Benefit	
Non-treatment wetland area (acres)	0
Treatment wetland area (acres)	0
Riparian habitat area (acres)	1
Non-developed open space area (acres)	34
<b>Multiple use / recreation area (acres) – additionally, select the type of multiple use / recreation and associated acres by type</b> Single Sport Athletics                      0 Multiple Sport Athletics Acres            0 Other Recreation Acres                      0 Pedestrian Trail Acres                        0 Equestrian Trail Acres                        0 Other Passive Activity                        0 Other Acres (describe)                       1 Description (Public Access, Open Space, Habitat, Recreation) recharge basin	
<b>Total Project area (acres)</b>	<b>36</b>

## 5.) Project Cost Estimate

Project cost information is needed to assist in comparing benefits and cost. Additionally, knowledge of the project type and cost will assist in identifying funding sources for potential projects.

Please indicate the estimated total capital cost for project implementation. These costs include land purchase/easement, planning/design/engineering, construction/implementation, environmental compliance, administration, and contingency.

Lower Estimated total capital cost (\$)	250000000.00000000
Upper Estimated total capital cost (\$)	300000000.00000000
Of the total capital cost, please indicate the estimated cost for land purchase / easement (\$)	100000.00000000
Annual Operation and Maintenance Cost (\$)	1000000.00000000
Design Life of Project Years (years)	30

## **Appendix E**

-

### **LA IRWMP Benefits Assessment Framework**

# IRWMP Benefits Assessment Framework

Revised Draft

21Jun06

## Table of Contents

1	Introduction.....	3
1.1	Greater Los Angeles County Integrated Regional Water Management Plan .....	3
1.2	Benefit-Cost Analysis in Water Resources Planning.....	4
1.3	Purpose of the Benefits Assessment Framework.....	4
2	Economic Concept of Benefits .....	5
2.1	The Value of Natural Assets.....	5
2.2	Identifying Project Benefits .....	6
2.3	Estimating Project Benefits.....	6
2.4	Benefit Transfer .....	8
3	Water Supply Benefits .....	8
3.1	Water Suppliers in the GLACO Region .....	9
3.1.1	Local Water Supply Agencies .....	9
3.1.2	Regional Water Supply Agencies .....	10
3.2	Meeting Future Demand in the GLACO Region.....	11
3.2.1	Local Water Supply Development.....	12
3.3	Water Supply Benefit Estimation Approach.....	13
3.3.1	Avoided Costs of Increased Water Supply .....	14
3.3.2	Value of Increased Local Reliability .....	14
3.4	Water Supply Benefits Example Application.....	16
4	Water Quality Benefits .....	17
4.1	Total Maximum Daily Load Requirements .....	18
4.2	The Value of Water Quality.....	18
4.2.1	Sources of Water Quality Value .....	19
4.2.2	Components of Water Quality Benefits.....	20
4.3	Water Quality Benefits Assessment Method.....	21
4.3.1	Water Quality Benefits that May be Assessed If Data is Available .....	21
4.3.2	Water Quality Benefits Included in the Assessment Framework.....	22
4.3.3	Water Quality Benefits Example Application .....	24
5	Benefits of Other Beneficial Uses.....	24
5.1	Project Related Land-Uses and Services .....	25
5.2	Benefit Transfer .....	25
5.3	Habitat Services .....	26
5.4	Recreation Services.....	26
5.5	Aesthetic Services.....	28
5.6	Flood Control Services .....	30
5.6.1	Other Beneficial Use Benefits Example Application .....	30
6	Total Project Benefits .....	30
7	Framework Examples from Step 2 Application Projects.....	31
7.1	JWPCP Marshland Enhancement Project.....	31
7.2	Large Landscape Water Conservation, Runoff Reduction, And Educational Project .....	33
7.3	Eighth Street Park – Pacoima Wash Greenway .....	35
8	References.....	36

# 1 Introduction

## 1.1 Greater Los Angeles County Integrated Regional Water Management Plan

In November 2002, California voters approved Proposition 50, titled “Water Quality, Supply and Safe Drinking Water Projects, Coastal Wetlands Purchase and Protection Bonds Initiative Statute.” Prop 50, as it is commonly known, provides \$3.4 billion in bond monies for a variety of water projects. In 2005, during the first round of funding, only one of six entities that applied for funding from the Greater Los Angeles County region was awarded monies by the State. The State agreed to increase funding for the Greater Los Angeles County region if all of the entities joined together to develop one strategic plan for the County. This plan is the Greater Los Angeles County Integrated Regional Water Management Plan (IRWMP).

For the purpose of the IRWMP, definition of the Greater Los Angeles County Region (GLACO) is based on the juxtaposition of watersheds and political jurisdictions. GLACO includes most of Los Angeles County plus small portions of Ventura County and Orange County, which overlap into the major watersheds of Los Angeles County. The IRWMP divides the GLACO region into five hydrologic subregions: South Santa Monica Bay, North Santa Monica Bay, Upper Los Angeles River, Lower San Gabriel and Los Angeles Rivers, and Upper San Gabriel Valley and Rio Hondo Watersheds.



The purpose of developing an Integrated Regional Water Management Plan is to address water supply and water quality needs and objectives through cost-effective, often multi-purpose water management solutions. The IRWMP integrates strategies and projects with a focus on synergy among approaches to improving water supply, water quality and other beneficial uses of water resources. The sought after result is an integrated plan that

leverages the potential for increased benefits through coordination among individual projects. The IRWMP builds on projects already submitted for Prop 50 funding and integrates new projects through a stakeholder-driven process. The nature and extent of benefits derived from the IRWMP will also be used to attract additional funding sources, such as federal funds via the Army Corps of Engineers, US Dept. of the Interior, and US Environmental Protection Agency.

## **1.2 Benefit-Cost Analysis in Water Resources Planning**

Benefit-cost analysis has long been an instrument of water resources planning (ref.). In 1983, President Reagan signed an Executive Order authorizing the “Economic and Environmental Principles and Guidelines for Water and Related Land Resources Implementation Studies” developed by the US Water Resources Council. These principles and guidelines established the conceptual benefit-cost analysis process for all federal water resources projects. Since that time there has been a large effort to extend the quantification of the economic benefits of water resource projects into areas of benefits that had previously not been accounted for in a dollar metric. It is now common, through the application of continually evolving methods, to see benefits assessed for improvements in environmental services and to have those benefits used in the benefit-cost approach to project justification.

Nonetheless, not all benefits resulting from water resources projects lend themselves to monetary evaluation. Some benefits may be too costly to adequately evaluate on a dollar basis. The monetary evaluation of other benefits may be beyond the reach of existing methods, and are not universally accepted as a component of a benefit-cost analysis. Because of these limitations on the scope of water resources project benefit assessment, benefit-cost analysis is recommended as one of many planning tools and is not intended to be the sole determinant of project justification.

## **1.3 Purpose of the Benefits Assessment Framework**

The purpose of the benefits assessment framework is to quantify, in monetary terms, improvements to the “beneficial uses” of water as identified by the California State Water Resources Control Board and any other improvements that may result from projects contained within the IRWMP. The benefits assessment framework provides the consultant team and decision makers with a tool that supports the integration of separate and often single purpose water resources projects into a county-wide water management plan. The benefit assessment framework can be used to compare the estimated benefits of differing multi-purpose projects or project combinations against the benefits of other project groupings or individual stand-alone component projects.

The benefits assessment framework provides input into the formulation of a regional integrated plan through the categorization and quantification of project benefits under a consistent metric. The goal of the benefit assessment framework is to identify opportunities to increase net benefits county-wide, through the integration of individual projects or project purposes into a more cost-effective program. Benefit values used in

this framework are largely based on value estimates established in the Environmental and Natural Resource Economics Literature, avoided costs, or value estimates provided by project sponsors.

## **2 Economic Concept of Benefits**

### **2.1 The Value of Natural Assets**

Economists regard environmental resources, including water resources, as natural assets that generate value in the same manner as all other assets. The value of a water resource asset can be generically defined as the discounted sum of the human well being provided by water resource services during the useful life of the resource. A few components of this definition require explanation. First of all, benefit-cost analysis deals in anthropocentric values. Value is defined in terms of the human well being provided by water resources. Values may be influenced by impacts to non-human entities, but only to the extent that humans perceive and respond to those impacts.

Second, the value of water resources is based on the services provided by the resources and not directly on the environmental functions or processes conducted by the resources. Services are the end products that directly affect human well being, while ecosystem functions and processes are the physical, chemical, and biological interactions that generate the services valued by people (Boyd and Banzhaf, 2005). From this perspective, the value of a patch of wetland, for example, would be based on the flood control services it provides, or the water treatment service it provides, or the fishery/benthic habitat it provides, or any combination of those services and more. But, in a benefit-cost analysis the wetland would not be evaluated for the physical functions that do not provide services to humans, such as transpiration.

The third component of this definition of value that requires some explanation is the discounting that takes into account the difference in value between services received today and services received at some future date. The preference for receiving a good or a benefit today over receiving that same good at some time in the future is a fundamental economic concept. This concept underlies some of the most basic functions of the economy, such as the interest required to induce money lending and bank deposits. The discount rate expresses the preference for current over future benefits. The higher the discount rate the greater the preference for current benefits, and therefore future benefits are discounted more heavily. Determination of the appropriate discount rate for changes to natural assets across generations has been and continues to be a focus of study for environmental and natural resource economists, with the consensus that the appropriate rate is typically lower than other discount (or interest) rates encountered (Freeman, 1993). Benefit cost analyses that will affect the allocation of federal funds are required to use the appropriate discount rate identified by the Office of Management and Budget each fiscal year.



## **2.2 Identifying Project Benefits**

Project benefits can be most simply defined as the total gain in well being (value) provided by the project in question. Some component of this gain may be expressed in monetary terms, as will be described below. Other components of this gain cannot be expressed monetarily, or require extensive data gathering and analysis for their approximation and therefore typically remain outside of the benefit framework. These difficult to evaluate components of project benefits generally fall under the category of non-use values (Freeman, 1993) or intrinsic values (Raucher, et al 2005).

The appropriate measure of benefits resulting from water resources improvements is “willingness-to-pay”, which is the total amount the beneficiary is willing to pay for the improvement. In theory, benefit-cost analysis compares the full cost of improving the resource, which similarly includes components that are readily quantifiable in monetary terms and other components that are not, to the total benefit as described above. In practice, willingness-to-pay for water resource improvements is difficult to observe and costly to quantify (Young, 2005). Water resources projects often rely on observed expenditures or on stated preferences to infer project benefits.

The difficulty related to observing willingness-to-pay for water resource improvements is based on the characteristics of the market or lack of a market for water resources. Water resources are typically not bought and sold in a competitive market setting. Water resources which are traded in a market, such as water supply for residential and commercial use, are seldom traded in a competitive setting due to numerous market distortions resulting from subsidies and other government programs (Raucher et al, 2005). Other water resources, such as creeks and rivers that receive and transport storm water flow, do not have their services traded in a market. The demand and associated willingness-to-pay for these resources exist outside of an observable market. Because of these non-competitive market and non-market conditions for water resources, the willingness-to-pay for these resources cannot be observed directly.

## **2.3 Estimating Project Benefits**

In order to estimate the value of water resources improvements, environmental and natural resource economists have developed a variety of methods that either estimate the willingness-to-pay for the resource improvement or infer value from some observed phenomena, such as price differentials. Each valuation method has its appropriate application and comes with its own set of caveats. This benefits assessment framework relies on the following approaches to evaluate project benefits:

- Avoided costs;
- Revealed preferences;
- Stated preferences; and
- Hedonic pricing.

In addition, the benefit assessment framework uses a flood protection valuation model developed by LA County. Benefit estimates developed by others for projects submitted into the IRWMP are also presented in this benefits assessment framework.

The avoided cost approach to benefits assessment provides an inferred value for the resource improvement by calculating cost savings that may be associated with implementation of the improvement. An example, which will be developed more fully in section 3.3.1, is the avoided cost of imported water due to development of local water supply sources or conservation. The rationale for using avoided costs is twofold. First, the information needed for this approach is typically available and is in dollar terms that are generally understood. Second, cost savings are a component of the total value of the improvement. If avoided costs alone are used to represent the value of the improvement, then it should be understood that total benefits are at least as large as the calculated avoided costs. Other, separable components of total value may be combined with avoided costs to provide a more complete estimate of project benefits.

Revealed preferences and hedonic pricing approaches are based on observed behavior. Resource values are inferred through revealed preferences by observing the price difference between similar goods, which have a major differentiating characteristic, such as similar houses that are located near or far from desirable public parks. In this benefits assessment framework, the value of water supply reliability is inferred from Shortage Stage 7 allocation enforcement rate surcharges.

Project benefits based on revealed preferences should be viewed as a component of total project benefits, which are at least as large as the benefits estimated through the revealed preference. Water supply rates (prices) are not indicative of willingness-to-pay because they provide no information on how much more the consumer would be willing to pay if the price were higher. In addition, there is seldom opportunity to observe sufficient variation in water supply rates in a manner that would allow development of a demand function that displays willingness-to-pay across varying price and quantity.

Benefit estimates based on the hedonic pricing approach are developed under the assumption that the total price for a good is equivalent to the sum of inferred prices for individual characteristics of the good. A common example of hedonic pricing is applied in the housing market, in which the value of a house is equivalent to the sum of the prices of its component characteristics such as lot size, number of rooms, number of bathrooms, etc. In the environmental economics and natural resource literature it is common to find studies that evaluate natural resources or natural resource quality by including the quantity or quality of the resource as a component characteristic of house values. The value of parklands, open space, and wetlands has been estimated in this manner, as will be discussed in section 5.

The stated preference approach is used to estimate an individual's willingness-to-pay for resource improvements. This approach uses survey instruments to depict conditions with and without the improvement. A questionnaire is used to collect the individual's stated willingness-to-pay and additional personal information, which is often used to explain differences in willingness-to-pay among respondents. Stated preference approaches have the potential to estimate the total value of the resource improvement, but there are many impediments to accuracy, which have been the focus of much research over the years. In

addition, high quality stated preference studies are typically expensive to execute due to survey instrument development and data gathering costs.

## **2.4 Benefit Transfer**

This benefit assessment framework presents the methods and values selected to assess and compare the benefits of various projects and project combinations. The level of detail, or resolution, of the benefit estimates used in this framework is appropriate for development of a master plan consisting of component projects. A greater level of detail and perhaps the use of alternative benefit estimation approaches may be required of a benefit-cost analysis aimed at individual project justification.

Many of the benefit estimates used in this benefits assessment framework are based on value estimates developed for other studies. For example, there were no stated preference or hedonic pricing analyses conducted specifically for this benefits assessment, but stated preference and hedonic pricing analyses conducted for similar water resources in other areas are used to infer the value of water resource improvements in the GLACO region. The use of benefit estimates conducted for other purposes in other areas is known in the environmental and natural resource economics literature as benefit transfer.

The cost and time required to conduct original benefit estimation analyses makes benefit transfer an economically feasible approach to project benefit estimation. Benefit transfer is typically employed for projects whose scope and anticipated impact don't justify the cost of an original benefits analysis. For the IRWMP, benefits transfer is a reasonable alternative because the purpose of the IRWMP is the development of an optimal mix of projects and not the justification of individual projects. Extensive research has been and continues to be conducted on benefits transfer (ref.). Based on that growing body of research, various criteria have been developed as guidelines for successful application of benefits transfer (ref.). In general, the greater the similarity between resource characteristics, scope and nature of the improvement, and the characteristics of the impacted population, the higher the confidence in the benefits transfer application. The appropriateness of applying benefits transfer for each category of beneficial use is discussed in each of the following sections that develop benefits estimates.

## **3 Water Supply Benefits**

This benefits assessment framework estimates the benefits of water supply improvements through an avoided costs approach. As discussed above, estimates of willingness-to-pay would be the theoretically correct estimates of water supply improvements but, for reasons that will be described below, an alternative estimation approach is used. In this analysis, water supply benefits are calculated as the sum of

- avoided costs of imported water, and
- avoided shortage stage surcharges.

The costs and surcharges used in the avoided cost approach are based on published rates and surcharges. The avoided shortage stage surcharge costs are representative of the value of increased reliability due to the local water supply project.

The water supply benefits assessment method discussed below is a conservative, yet consistent, estimate of benefits, which can be used to compare and coordinate projects based on the water supply benefits they provide. The estimates provided by this method are considered conservative because true water supply improvement benefits would be at least as large as (though no less than) the benefits resulting from the application of this method.

This section proceeds in the following manner:

- a brief discussion of the institutional structure of the GLACO region water supply system;
- a brief discussion of the various types of water supplied;
- a description of the benefit estimation approaches used for the IRWMP, with examples; and
- discussion of other water supply benefit estimation approaches and estimated values from the relevant literature.

### **3.1 Water Suppliers in the GLACO Region**

#### **3.1.1 Local Water Supply Agencies**

Overall, there are about 100 entities that provide water to end users in the GLACO region. The local sources for these 100 local supply agencies are mostly groundwater with some additional recycled and reclaimed water sources. The water supply required to meet GLACO regional demand, which cannot be met through local sources, is purchased from the Metropolitan Water District of Southern California (MWDSC) and San Gabriel Valley MWD through 22 member agencies 18 of which are Metropolitan's and 4 are San Gabriel Valley MWD's. Some of these 22 agencies act as wholesalers to the 100 entities mentioned above while others provide water to end users.

MWDSC and the San Gabriel Valley MWD do not supply water directly to GLACO municipal and industrial end users. Among the local supply agencies in the GLACO region, the Los Angeles Department of Water and Power is unique in that its "local" supplies include

- surface water from Mono Lake and the Owens River in the eastern Sierra Nevada via the Los Angeles Aqueducts, and
- State Project Water from the San Joaquin-Sacramento River Delta in Northern California via the California Aqueduct (Water Supply Tech Memo p. 16).

The following table presents the sources for the 2005 potable water supply for most of the local supply agencies in the GLACO region. These figures indicate the reliance on "imported" water from the MWDSC. With the exception of the City of Los Angeles, the second most significant water supply source for the GLACO region is local groundwater. Reclaimed and recycled water provides a relatively small supply volume in the GLACO

region. Most local supply agencies have identified plans to increase local supply sources. Some of the component projects of these plans have been, or will be, proposed for potential Prop 50 funding.

2005 MWDSC and Local Water Supply Proportions

Local Agency	Imported Supply	Local Supply and Source
MWDSC Member Agencies		
City of Beverly Hills	90%	10% groundwater
City of Burbank	71%	29% groundwater
Central Basin WMD*	24%	74% groundwater, 2% reclaimed
City of Compton	44%	56% groundwater
Foothill WMD*	60%	40% source info needed
City of Fullerton	Info needed	Info needed
Glendale	69%	27% groundwater, 4% recycled
Las Virgenes MWD	100%	0% source info needed
City of Long Beach	60%	35% groundwater, 5% recycled
City of Los Angeles	85%	15% groundwater, < 1% reclaimed
MWD of Orange County*	50%	50% groundwater, < 1% reclaimed
City of Pasadena	60%	40% mix of surface and groundwater
City of San Fernando	20%	80% groundwater
City of San Marino	Info needed	Info needed groundwater
City of Santa Monica	88%	10% groundwater, 2% recycled
Three Valleys MWD	55%	45% groundwater
City of Torrance	65%	23% recycled, 8% desalted groundwater, 4% groundwater
West Basin WMD*	64%	29% groundwater, 7% reclaimed
San Gabriel Valley WMD Member Agencies		
City of Alhambra	23%	77% groundwater
City of Azusa	0%	100% groundwater
City of Monterey Park	0%	100% groundwater
City of Sierra Madre	0%	100% groundwater
Note: * indicates wholesaler. Source: Water Supply Tech Memo		

### 3.1.2 Regional Water Supply Agencies

Although there are two regional water supply agencies that have member agencies within the GLACO region, the MWDSC is the largest provider of imported water to the region. The MWDSC's total service area is 5,178 square miles, of which 1,200 (23%) is within the GLACO region. [MWDSC's service area does not include most of Angeles National Forest which is in the GLACO region.] The MWDSC draws its water supply from the Colorado River, via the Colorado River Aqueduct and from the Feather River watershed through the San Joaquin-Sacramento River Delta in Northern California via the California Aqueduct. Water supplied through the California Aqueduct is also known as "State Project" water. All of the MWDSC supply is considered imported water.

Total retail demand within the MWDSC service area in 2005 was 4,115,700 acre-feet. The GLACO region accounted for 46% (1,908,476 acre-feet) of that demand (Water Supply Tech Memo p.6). The GLACO region's need for imported water is largely dependent on local groundwater conditions.

### **3.2 Meeting Future Demand in the GLACO Region**

In November 2005, the MWDSC published its newest five year plan titled "The Regional Urban Water Management Plan". The major requirements of this plan, stated in broad terms are to provide:

- Detailed evaluations of water supplies to meet demands over the next twenty years under conditions of single-year and multi-year droughts and average-year conditions;
- Descriptions of action plans that would be implemented during times of drought and during service interruptions; and
- Identification of water supply projects and implementation schedules needed to meet the forecasted demand (MWDSC p.I-1, 2005).

The MWDSC cannot require local member agencies to implement specific water supply projects, however voluntary coordination between MWDSC planning and local agency planning is anticipated (MWDSC p.I-2&3, 2005).

The MWDSC has identified demand from its full service area through 2025 and has identified resource projections that will fully meet that demand. Demand for imported water is largely based on local production. If the resource projections are not developed, existing sources and conservation levels will support only 81% of demand in a dry year (Water Supply Technical Memo, p. 43, 2006). Without the development of resource projections, the MWDSC will need to increase future purchases of imported water to fill the demand-supply gap. The table below presents current supplies, future supply projections that fully meet forecasted demand, and the water supply gap that would exist if supplies remained at current levels (all values in acre-feet). The gaps identified in this table are the resource development goals for each type of supply, which have been identified jointly by MWDSC and member agencies..

Type of Supply	MWD Supplies	MWD IRP Targets				MWD Gap or (Excess)			
	Current	2010	2015	2020	2025	2010	2015	2020	2025
Conservation	730,000	865,200	946,400	1,027,600	1,106,900	135,200	216,400	297,600	376,900
Local Production (groundwater, surface water, LA Aqueduct)	1,295,300	1,808,966	1,860,080	1,911,193	1,922,608	513,666	564,780	615,893	627,308
Local Projects (recycled water, groundwater recovery, desalination)	273,000	410,000	580,000	750,000	750,000	137,000	307,000	477,000	477,000
Groundwater Conjunctive Use	107,000	275,000	287,500	300,000	300,000	168,000	180,500	193,000	193,000
State Water Project Colorado River Aqueduct	460,000	463,000	556,500	650,000	650,000	3,000	96,500	190,000	190,000
CVP/SWP Storage and Transfers	740,000	1,001,000	1,064,500	1,250,000	1,250,000	261,000	324,500	510,000	510,000
MWD Surface Storage	417,000	300,000	425,000	550,000	550,000	(117,000)	8,000	133,000	133,000
	870,000	620,000	620,000	620,000	620,000	(250,000)	(250,000)	(250,000)	(250,000)
<b>Total</b>	<b>4,892,300</b>	<b>5,743,166</b>	<b>6,339,980</b>	<b>7,058,793</b>	<b>7,149,508</b>	<b>850,866</b>	<b>1,447,680</b>	<b>2,166,493</b>	<b>2,257,208</b>

Source: Water Supply Tech Memo

For the purpose of this IRWMP, the current water supplies were reviewed and a gap analysis was conducted for the GLACO regional component of MWDSC's service area (see Water Supply Tech Memo for complete discussion and analysis). The following table presents the results of the water supply gap analysis for the GLACO region.

	Supplies	GLACO IRP Projections				GLACO Gap or (Excess)			
	2005	2010	2015	2020	2025	2010	2015	2020	2025
<b>Totals</b>	<b>2,511,967</b>	<b>2,756,720</b>	<b>3,043,190</b>	<b>3,317,633</b>	<b>3,360,269</b>	<b>244,752</b>	<b>531,223</b>	<b>805,665</b>	<b>848,301</b>

Source: Water Supply Tech Memo

### 3.2.1 Local Water Supply Development

In order to meet the GLACO region's water supply projections identified in the preceding table, local supply agencies and MWDSC are investing in the development of new water supply projects. These projects are being incorporated into the IRWMP as they are currently identified. A large segment of the gap is allocated to local production. Local production is predominantly groundwater production, which includes projects to treat existing and future groundwater sources to remove contaminants and the capture of storm water runoff for recharge into groundwater basins for later extraction.

Storm water runoff is a major contributor to groundwater production along with some artificial recharge with imported water. Some storm water runoff percolates into ground water basins through permeable areas and stream channels that contain natural materials. Other storm water is captured in retention basins that allow the water to percolate into the ground water basin in a controlled manner. Other storm water flows through hardened

stream channels and piping that substantially reduce or eliminate percolation. This water is largely lost to the sea without contributing to groundwater replenishment. The benefits of improving storm water run off quality, apart from benefits generated by increased water supply, are discussed in Section 4 Water Quality Benefits.

Other gap areas include recycled water development, desalination, conservation and conjunctive use. The most important aspect of the local production gap is the cumulative amount. If any one local supply source were to be developed to a volume greater than its gap, then another source may be developed to a degree below its gap.

### **3.3 Water Supply Benefit Estimation Approach**

In this benefit estimation framework, water supply benefits are generated by local projects that either increase local supply or reduce local demand, thereby decreasing the volume of imported water purchased from the MWDSC. The preceding tables presented the local water supply development estimates or projections established by the MWDSC. The MWDSC's Regional Urban Water Management Plan (2005) anticipates that these projections will be met through local project development. The current MWDSC rate schedule includes a premium for purchasing water above a historic baseline. This premium, which is the difference between Tier 1 and Tier 2 rates (MWDSC, p. II-24, 2005), further encourages the development of local resources. However, if the development projections are not achieved, additional imported water in the form of transfers will be purchased and distributed to the local entities. Should transfers not be available, supply shortages will occur.

Projects that generate water supply benefits will increase local water supply volume in at least one of the following ways:

- Increase groundwater recharge;
- Increase groundwater recovery;
- Increase conjunctive use;
- Increase water transfers;
- Increase recycled water;
- Increase surface water capacity;
- Increase surface water capture and treatment; and
- Desalination.

In addition, conservation, which ultimately decreases demand of imported water, provides benefits in a manner similar to local supply increases.

The total value of a project's water supply improvements, which would include one or more of the improvements listed above, would ideally be identified in the willingness-to-pay for those improvements. However, estimating willingness-to-pay for water supply improvements is a difficult and expensive task to undertake and is one which would include a considerable amount of uncertainty (Young, 2005). The following sub-sections describe the water supply benefit estimation method used in this benefits assessment framework and a subsequent sub-section includes a discussion of water supply benefits estimates found in the environmental and natural resource economics literature.



### 3.3.1 Avoided Costs of Increased Water Supply

Any increase in local water supply production will decrease the volume of imported water demanded from the MWDSC. This reduced demand for imported water results in fewer purchases from the MWDSC and a cost savings for the local agencies<sup>1</sup>. The unit price of this cost savings depends on the type of water purchase avoided. Surface water improvements, conservation, desalination, replenishment for salt water barrier and increased recycling are assumed to replace water purchases at the Full Service Treated Tier 1 rate. Local water supply volumes resulting from projects that improve groundwater recharge and groundwater recovery also will generally be assumed to replace water purchases at the Full Service Treated Tier 1 rate. However, some projects may use improved replenishment sources without impacting Full Service Treated Tier 1 purchases because the additional replenishment is not used to satisfy end user demand. If projects of this type are identified, the improved groundwater production will be assumed to replace water purchases at the Untreated Replenishment Water Rate. The table below presents the relevant high and low rate projections for 2006 – 2010.

MWDSC Projected Delivery Rates (\$/ac ft)

Local Supply Type	Rate Type Avoided	2006	2007	2008	2009	2010
Surface Conservation Recycled Desalination	Tier 1 – High Estimate	\$453	\$478	\$537	\$572	\$601
	Tier 1 – Low Estimate	\$453	\$478	\$490	\$527	\$555
Groundwater Recharge Groundwater Recovery	RW Untreated - High	\$238	\$263	\$291	\$307	\$335
	RW Untreated - Low	\$238	\$248	\$254	\$275	\$303

Note: RW = Replenishment Water

Source: MWDSC

### 3.3.2 Value of Increased Local Reliability

The MWDSC Regional Urban Water Management Plan (2005) indicates that MWDSC can provide reliable water supplies under single-driest year and multiple-dry year conditions, if the required sources are developed to fill the gap. In addition, the analysis shows that MWDSC can provide reliable water supplies under historic-dry period conditions through 2030, assuming the required sources are developed. The Water Surplus and Drought Management Plan identified in the RUWMP (MWDSC p.II-15, 2005) calls for water allocation and overage surcharges only during extreme drought conditions (Stage 7). During extreme drought conditions, allocations would be enforced through surcharges and interruptible services may be reduced. The drought management plan does not call for disruption of Full Service supply types. Although reliable delivery by MWDSC has been developed as the focal point of the RUWMP, there is a strong

<sup>1</sup> It is assumed that overall demand for MWDSC water will not decrease to such a level that rates would be increased in order to cover MWDSC's fixed costs.

preference by local agencies for increased independence from reliance on imported sources.

Direct measurement of the willingness-to-pay for increased reliability in the GLACO region is confounded by a number of factors, including the already high level of reliability (both historic and forecasted) for MWDSC deliveries. Stated preference studies have been conducted, which ask respondents for the amount they would be willing to pay to avoid the results of hypothetical restricted water deliveries. Some studies have included descriptions of the results of hypothetical restricted water deliveries, such as brown lawns, ruined landscaping, etc (see CUWA, 1994). Raucher et al., (2005) provide a table of stated preference results from studies that assess the value of water supply reliability, typically based on hypothetical shortages. Annual willingness to pay per household to avoid shortages ranges from \$82 to \$421 (2003 dollars). It should be noted however, that responses to questions referencing hypothetical restricted water delivery do not necessarily represent the willingness-to-pay for improved reliability if the respondent considers the existing level of reliability a right and not an improvement (Freeman, 1993). Water users in the GLACO region may perceive historic and existing levels of reliability as their right and therefore something they need not purchase anew. A willingness-to-pay question under these conditions may be perceived as asking individuals for additional payment for something they are already in possession of, and the true value of reliability may be under-represented.

One perspective on the value of improved reliability is based on revealed preferences indicated in the price differential between interruptible and non-interruptible supplies. Perhaps a minimum value of improved reliability may be calculated as the difference between the MWDSC rate for Full Service Tier 1 supply (non-interruptible) and the rate for Replenishment Water (interruptible). This difference is consistent across the MWDSC rate projections for 2006 through 2010. This reliability premium is calculated as \$93/ac ft for untreated supply and \$118/ac ft for treated supply. The reliability premium is the same for the high rate and low rate forecasts. It is important to note that this reliability premium, as calculated from the MWDSC rate structure, indicates that the value of reliability is at least as much as the value calculated from these rates. Additional value for reliability, which is likely held by GLACO residents, is not expressed in the MWDSC rate structure. For this reason, the reliability premium as calculated above should be considered the lower bound value of improved reliability.

A more inclusive approach to evaluating reliability, which also is based on MWDSC rate differentials, uses avoidance of shortage stage surcharges to infer the value of improved reliability. Avoidance of drought related surcharges have been used to infer the value of improved reliability provided by Orange County's Groundwater Replenishment System, as reported in Raucher et al. (2005).

As indicated in section 3.2, by 2025, the GLACO region will experience a 19% shortfall in water supply during a dry year, if source development does not fill the identified gap. There are assumed to be three dry years in the GLACO region in each decade. The MWDSC's Water Surplus and Drought Management Plan (1999) discusses

“extraordinary conservation measures to cut water demands during droughts”. The RUWMP (2005) identifies a surcharge of \$175/acft for deliveries between 100% and 102% of the member’s allocation and a surcharge of three times the full service rate for deliveries above 102% of a member’s allocation, during periods of Stage 7 Shortage.

Each acre-foot of new local agency supply decreases the gap and avoids shortage stage surcharges three out of each ten years. In 2010, for example, the avoided shortage stage surcharge would be \$175/acft for 100% to 102% of the member’s allocation and \$1,803/acft (high rate estimate, \$1665/ac ft for the low rate estimate) for demand above 102%.

### **3.4 Water Supply Benefits Example Application**

As an example of the way that water supply benefits are calculated in this benefits assessment framework, consider two local water supply projects. The first project is a storm water capture and treatment system that includes a retention basin, some constructed wetlands, and a spreading area for groundwater recharge. This project provides 1,000 acre-feet per year of additional groundwater recharge, which is used to support local supply. The second project is a conservation program that includes refitting of residential plumbing fixtures with low-flow improvements. This program provides 1,400 acre-feet of conserved supply each year.

The table below presents the unit values that would be used to calculate the water supply benefits for these two projects in the year 2010, which is assumed to be a dry year for the purpose of this example. Benefits are calculated for a single year only in order to simplify the presentation. The full assessment would also calculate these benefits for each year of the life of the project (including the probability that any year may be one of the three out of ten that are dry years), discount the benefits for each year at the appropriate discount rate, and sum the discounted values to arrive at a present value, which represents the value of the flow of benefits over the life of the project. In addition, avoided costs would be based on rate projections through 2025, or later if available.

Water Supply Benefit Unit Values 2010 (dry year)			
		Water Supply Benefit Unit Values (\$/acft)	
Project Type	Project Volume (acre-feet)	Avoided Purchase Cost	Avoided Shortage Surcharge
Replenishment	1,000	\$601	\$175 and \$1,803
Conservation	1,400	\$601	\$175 and \$1,803

Notes: Unit values based on high cost rate estimates for treated Tier 1 and untreated replenishment water

The next step in the water supply benefits assessment process is to multiply the unit values by the total volume supplied to get a total water supply benefit. The calculation is straight forward except for the cost savings related to avoided shortage surcharge costs. This component of benefits must be distributed among excess demand from 100% to 102% and greater than 102%. For the purpose of this example, assume that 10% of excess demand falls within the 100% to 102% range and the remaining excess demand is

greater than 102%. Allocations will be determined by the MWSD board at the time of the shortage. The following table presents the avoided water costs and shortage surcharges for the two projects used in this example, which is the total water supply benefit provided by the two example projects in year 2010.

Avoided Cost and Shortage Surcharge Calculations – 2010 (dry year)

Project Type	Up to 102% Allocation	More than 102% Allocation	Total Benefit	Average Benefit
Replenishment	\$77,600	\$1,622,700	\$1,700,300	\$1,700
Conservation	\$108,640	\$2,271,780	\$2,380,420	\$1,700
Totals	\$186,240	\$3,894,480	\$4,080,720	\$1,700
Notes: Unit values based on high cost rate estimates for treated Tier 1 water				

The magnitude of these benefits should be considered with the understanding that the true benefits of increased reliability will be greater than values inferred through avoided costs and surcharges. Water supply reliability and water supply independence are major concerns for local supply agencies. The costs of some recent local supply agency projects indicate that local supply agencies are willing to pay as much as the average benefit per acre-foot calculated below (\$1,700) for increased water supply reliability and independence.

The year-2010 total calculated water supply benefit for the two example projects, which combined provide 2,400 acre-feet, is \$4,080,720. The average benefit per acre-foot is \$1,700. This economic benefit estimate is a conservative estimate of benefits because it is largely based on MWDSC rates and not on the willingness-to-pay for additional supply. The appropriate interpretation of the total benefit value provided in the table above is that the benefits of the two projects are at least as large as \$4,080,720 and the average benefit per acre-foot is at least \$1,700. Although this benefit estimate does not fully represent the true benefit of these two projects, it does provide a consistent metric for the assessment of multiple water supply projects in the GLACO region.

## 4 Water Quality Benefits

Improvements in the quality of storm water runoff, surface flows and groundwater would have a broad impact in the GLACO region. Water quality affects all aspects of water resource management and the benefits of water quality improvement would be realized in many different ways. This section of the benefits assessment framework identifies some of the recent focal areas of water quality improvements in the GLACO region and discusses the types of benefits that would result from the water quality improvements under consideration. This section also presents an approach to assessing project related water quality benefits that can be applied in the formulation of the IRWMP. The final discussion in this section looks at some of the water quality values found in the literature for the purpose of comparisons in magnitude and scope.

#### **4.1 Total Maximum Daily Load Requirements**

The Clean Water Act (CWA), passed in 1972 and amended in 1977 and 1987, initiated technology-based standards (end-of-pipe) for municipal and industrial discharges into the nation's waters. The use-based goal of the water pollution policy that supported the Clean Water Act was to attain fishable and swimmable waters. The technology-based standards initially implemented under the CWA have been more successful in cleaning up the more egregious water quality problems, especially in urban areas, than in cleaning up water quality problems stemming from non-point sources (Freeman, 2002).

As an alternative to technology-based standards, health and water quality-based standards have been developed that better address non-point source pollution. A major application of health and water quality-based standards are Total Maximum Daily Loads (TMDLs), which identify the sum total allowable pollutant load per water body regardless of the number and types of contributing sources. Development of TMDLs is required for any water body that does not meet water quality standards (impaired water bodies)

The Draft Strategy for Developing TMDL's and Attaining Water Quality Standards in the Los Angeles Region (California Regional Water Quality Control Board et al., 2002) states that more than 160 water bodies within the region exceed water quality standards (impaired water bodies). It further states that a consent decree requires an assessment of 92 TMDL analytical units throughout the region. The schedule for developing TMDL's runs from 2003 to 2012 and a number of these have been developed (see Water Quality Tech Memo). The major TMDL constituents in the GLACO region are bacteria, nutrients, metals, toxics, and trash.

In order to meet existing and future TMDL requirements, wastewater treatment plant discharge, all dry weather urban runoff and a significant portion of wet weather runoff will likely require some level of treatment (Water Quality Tech Memo p.19). Plans for meeting TMDL requirements are being included in the IRWMP as they are being developed. Achieving water quality standards in the GLACO region in a cost-effective manner has been the focus of numerous studies (see for example, Gordon et al., 2002; Gardiner et al., 2003; and Devinnery, et al., 2004). The cost of achieving TMDL requirements in the GLACO region has not yet determined, but estimates range from \$2.6 - \$7.4 billion (Devinnery et al, 2004) on the low end, to \$43.7 - \$284 billion (Gordon et al., 2002) on the high end.

#### **4.2 The Value of Water Quality**

Evaluating the benefits of water quality improvements is a difficult task for economists (Young, 2005). The difficulties inherent in this task are due to the:

- non-market nature of water resource services;
- wide variety of benefit types; and
- beneficiaries may or may not be users of the resource.

Although the concept of value for improvements in water quality is similar to improvements in other resources, observing and measuring willingness-to-pay for water quality improvements is often an enormous and elusive task.

#### 4.2.1 Sources of Water Quality Value

The benefits of any water quality improvement project could be based on multiple perceptions and uses of the water resource, which are the sources of water resource value. Because the value of water is based on multiple perceptions and uses, the benefits of water quality improvements are similarly distributed among a variety of benefit types. The primary distinction among benefit types is between use and non-use benefits. Use benefits are based on some use of the water resource such as recreation, habitat improvement, water supply, etc. Non-use benefits are benefits that don't require use by the beneficiary, such as knowledge that a wilderness area you never plan to visit remains pristine or having that area available as pristine wilderness for future generations (Freeman, 1993). Non-use benefits of water quality improvements have been expressed in stated-preference studies that evaluate the willingness-to-pay for water quality improvements.

An example of non-use benefits is evident in a study of the value of water quality improvements for California residents conducted in 2000 (Larsen and Lew, 2000). This study asked a state-wide random sample of 2,000 California households their willingness to pay for the full removal of impairments to all California water bodies. The average response was \$23 per household per month. Given the broad scope of benefits (all California water bodies) it is reasonable to assume that some portion of the stated willingness-to-pay would be for improvements that the respondent doesn't expect to ever use directly. The size of the non-use component of benefits is unknown and was not a focus of the study, but some level of non-use value is included in the \$23/household willingness-to-pay estimate provided by respondents.

The natural resource and environmental economics literature includes numerous studies and discussions concerning the attributes and components of non-use values. For the purpose of the IRWMP, it is important to acknowledge the existence of non-use values as a component of total water quality benefits. Although the use values of water quality improvements will receive more discussion in this benefits assessment framework, the significance of the non-use component of water quality benefits should not be understated. Non-use values, which are difficult to assess through conventional benefits analysis are likely not fully reflected benefit-cost studies. This under-representation of non-use values may partially explain why voters and environmental agencies support environmental initiatives which appear to cost more than the benefits they provide (Freeman, 2002).

Use values related to water quality improvements are based on consumptive and non-consumptive uses of the water resource. Consumptive use includes water supply and groundwater recharge for non-supply purposes, such as reducing salt water intrusion. Non-consumptive uses include uses related to stored water and in-stream flow. Examples of non-consumptive uses of water resources include:

- Recreation (boating, fishing, swimming, etc.);
- Transportation;
- Hydropower;
- Industrial cooling;

- Habitat creation and sustainability; and
- Aesthetics (view, open space, cultural amenity, etc.).

#### **4.2.2 Components of Water Quality Benefits**

A project that improves water quality could, conceivably, impact each of the sources of value listed in the previous section. A full assessment of the economic value of water quality improvements would need to identify each of the physical, chemical, and biological impacts of the water resources project and then determine the effect of each impact on each source of value. The full economic impact would be the net effect on all sources of value.

In practice, such an extensive study would be expensive and difficult to implement, and few such studies have been conducted (Young, 2005). More typically, only the major expected impacts of the project are assessed for economic benefits, although the full set of physical, chemical, and biological impacts are assessed under NEPA and/or CEQA. Many of the use value related benefits resulting from a water quality project are separable elements because they are based on different uses of the resource. These benefits may be assessed as separate components of total benefits and summed to approximate the water quality benefits of a project.

The components of water quality benefits are assessed through the same approaches as other environmental amenities, which include revealed preferences, stated preferences, and avoided cost approaches. The following is a list of use-based benefit types that may be generated by a water quality improvement project:

- Avoided purchase of imported water;
- Avoided water treatment costs;
- Avoided sediment removal costs;
- Avoided damages;
- Avoided health risks;
- Increased recreational use;
- Improved recreational experience;
- Increased aesthetic value of water and related habitat; and
- Increased property values.

Non-use values of water quality improvements can be inferred through stated preference studies however, identifying the non-use value as a separable component of value that can be added to the use value components listed above is a difficult task. Double counting is an important concern in the estimation of water quality benefits, for non-use and use values.

In this benefits assessment framework, some of the components of water quality benefits are assessed under other headings, such as Water Supply and Other Beneficial Uses, which include recreation and property values. The water quality benefits assessment method discussed in the next section focuses on the components of water quality benefits not addressed in other sections of the framework.

### **4.3 Water Quality Benefits Assessment Method**

The components of water quality benefits which are calculated under other headings within this benefits assessment framework (water supply and beneficial uses) are separable elements that can be added to the benefits assessed under this heading in order to estimate total project benefits. Because of the varied nature of water quality benefit types and beneficiaries, there is no consistent standard by which benefits may be assessed. For example, water supply benefits are largely based on avoided costs and an observable price differential from which the value of reliability is inferred. Water quality does not have a related cost structure in place which could be used as a benefits benchmark. Avoided treatment costs cannot be used to infer benefits of water quality improvements in the GLACO region because a reference cost structure does not exist.

In using avoided costs as benefits, the costs avoided must be costs that would be definitely incurred if the water quality project were not to take place. In the case of water quality in the GLACO region, an alternative plan for water treatment with known costs and a high likelihood of implementation needs to be in place so that avoidance of implementing that plan with a cheaper plan results in a cost savings (see discussion in Young, 2004 concerning Alternative Cost Method). At this time, treatment plans with high likelihood of implementation do not yet exist, as many of the treatment plans are currently being developed and all of the required TMDLs have not been developed yet.

#### **4.3.1 Water Quality Benefits that May be Assessed If Data is Available**

Avoided damages is a component of use value-based benefits that cannot be directly included into this benefits assessment frame work because of the limited data available. Avoided damages are sensitive to project characteristics and cannot be generalized across project and types. A good example of potential damages related to water quality is the economic value of beach closures. Beach closures related to storm water occur each year in the GLACO region. A survey of Los Angeles beach users, conducted in 2000, revealed that nearly 50% of respondents cited water quality as the major reason for not going to the beach (Pendleton, et al., 2001). Beach goers who are turned away from a closed beach, or who choose to go to an alternative beach, or who choose not to go to the beach at all because of a closure incur an economic loss for not having taken and enjoyed their beach trip. An individual's value of a beach trip (above an beyond expenses incurred) in southern California has been valued in a range from \$11 to \$40 per trip (1990 dollars) and the estimate used in the Natural Resource Damage Assessment for the *American Trader* oil spill off Huntington Beach was \$15/trip in 1990 dollars (City of Huntington Beach, 2002).

Water quality improvements that would reduce beach closures would generate an avoided damage benefit equivalent to the number of beach trips affected multiplied by the per trip value of beach recreation. If the number of affect beach trips were known, then a benefit transfer value could be applied from other studies of southern California beach use. In addition, if water quality improvements were to increase the quality of a beach trip then



the economic value of that improvement would also be a project benefit. However, without the required data the avoided damages benefit for water quality improvements cannot be calculated as a part of this benefits assessment.

Health-related benefits could also be calculated as a component of water quality benefits if the appropriate data is available. Economic evaluation of air and water quality impacts on health has been a focal point of research and has a growing literature. In keeping with the storm water – beach use example, a study by Martin and Pendleton (2000) cites research conducted for the Santa Monica Bay Restoration Project (Hailer et al., 1996), which found that individuals swimming near flowing storm drains were 50% more likely to develop nausea, fever, gastroenteritis, and sore throat than individuals who swam at least 400 yards away from the outlet. Avoidance of damages associated with health effects (medical costs, lost wages, etc) are a benefit of water quality improvements. Again, these benefits can not be included in this benefits assessment frame work unless the appropriate data were available.

The third component of water quality benefits that could be applied in this benefits framework if the data were available is the avoided costs of sediment removal from navigable waters and natural areas. Maintenance dredging is periodically conducted at all ports and harbors in the GLACO region. In addition, dredging is also conducted for habitat improvement and maintenance in the remaining estuarine areas within the GLACO region. To the extent that storm water treatment reduces sedimentation in navigable waters and habitat areas, any reduction in associated dredging costs is a water quality project benefit. Estimation of this benefit requires calculation of the sediment volume reduction that would impact specific navigation or habitat related dredging projects. The impact to the dredging project may be a reduction in the amount of material dredged per cycle or a lengthening of dredging cycles. If the dredging reduction volumes were known, appropriate costs per cubic yard could be derived from local active dredging projects and the benefit could be calculated.

Finally, any reductions in treatment costs at existing treatment plants, due to the improved quality of input water, would be an avoided cost suitable for inclusion as a water quality benefits. The level of detail required to calculate these cost savings however, including existing treatment plant cost structures, existing and future input water quality levels, and the impact of cleaner input water on treatment plant operation (reduced filter and screen maintenance, etc) are beyond the level of detail expected of plans submitted for inclusion into the IRWMP. Although these avoided costs are expected to be real benefits of improved water quality, they are not included in this analysis due to data limitations.

#### **4.3.2 Water Quality Benefits Included in the Assessment Framework**

Up to this point, water quality benefits have been identified which are assessed in other sections of this benefits assessment framework (water supply and beneficial uses) and which would be assessed by this framework if the appropriate data were available. The components of water quality benefits that have not yet been addressed are based on non-

use values, which would not be captured within the use value based benefits discussed above.

Non-use values are well established in the natural resource and environmental economics literature although their estimation remains controversial (Young, 2005). Non-use values may play an important part in the benefit estimation of a water resources project and ignoring them would potentially result in a misallocation of project funds (Freeman, 1993). Non-use values are typically estimated using the stated preferences approach. One such study has been conducted by Larson and Lew (2000) concerning water quality in California, although not specifically for the GLACO region. Their analysis is based on a random survey of California residents, which asked for their willingness to pay to “fully remove impairment to California sources of water” (Larsen and Lew, 2000).

Respondents provided an average willingness to pay of \$23 per month per household. This value was adjusted to \$15.46 per month per household to reflect the average California household based on characteristics such as income and education. The monthly value is the equivalent of \$185.52 per year. Using an average of 2.5 persons per household and 30 million people as the estimate for California’s population there are approximately 12 million households within the state. The annual statewide willingness to pay for removal of impairments from all California waters is calculated to be \$2.23 billion (12 million \* \$185.52 = \$2.23 billion).

An appropriate adjustment to this value, which would represent the value of removing all impairments in the GLACO region, would be based on the proportion of California’s impaired water bodies that are located in the GLACO region. The State’s section 303(d) list as approved by the USEPA in 2003 identifies 509 impaired water bodies, including XX,XXX acres of lakes and tidal water and X,XXX miles of rivers and stream. Of this total quantity of impaired water bodies, X,XXX acres and XXX miles are located in the GLACO region. Approximately XX% of the impaired water body acreage and XX% of the impaired water body mileage is located in the GLACO region. A reasonable approximation of the overall proportion of the state’s impaired water bodies located in the GLACO region is 22% . The annual statewide willingness-to-pay for removal of impairments to waters in the GLACO region, based on the value estimates provided by Larsen and Lew (2000) is \$490 million (\$2.23 billion \* 22% = \$490 million).

This annual value (\$490 million) can be prorated to reflect a value per acre-foot of water treatment in the GLACO region using annual estimates of POTW effluent and storm water runoff. The Water Quality Tech Memo (2006) estimates 218,025 annual acre-feet of discharge from the GLACO region’s POTWs. The same document also estimates annual urban storm water runoff in the GLACO region to be 650,000 acre-feet. The total potential treatment volume from these two sources is 868,025 acre-feet annually. The resulting annual statewide willingness-to-pay per treatment acre-foot in the GLACO region is \$564 (\$490 million / 868,025 acre-feet = \$564/ ac ft).

### **4.3.3 Water Quality Benefits Example Application**

As an example of the way that water quality benefits are calculated in this benefit assessment framework, consider the storm water capture and treatment project that was used as an example for water supply benefits. This project includes a retention basin, some constructed wetlands, and a spreading area for groundwater recharge. This project provides 1,000 acre-feet per year of additional groundwater recharge, 2,500 acre-feet of storm water treatment, and 12 acres of constructed wetlands.

The water supply related benefits of this project have been calculated in section 3 as \$1,299,800, which will be added to the water quality and beneficial use benefits (section 5) to arrive at a total project benefit. The separable water quality benefit of the project, based on an adjusted estimate from the stated preference study conducted by Larsen and Lew (2000), is \$1.41 million ( $\$564 * 2,500$  acre-feet of treatment = \$1.41 million). This \$1.14 million water quality benefit estimate does not include the potential benefits from areas that require additional information such as sedimentation, beach closures, and health effects. The sum of water supply and water quality benefits of this project is \$2,439,800. The next section discusses the separable benefits of constructed wetlands and other beneficial uses.

## **5 Benefits of Other Beneficial Uses**

Numerous types of benefits, other than those directly related to water supply and water quality, may be generated by a water resources project. These benefit types, often referred to as beneficial uses, may be ancillary to the primary purpose of a water resources project, such as bird habitat related benefits that might result from construction of a treatment wetland. Although ancillary, the benefits from beneficial uses other than primary project purposes may be instrumental in the formulation of a water resources plan that provides the greatest economic benefit, which includes both ancillary and primary purpose benefits.

The benefits of other beneficial uses may be categorized in various ways however, for the purpose of this benefits assessment framework other beneficial use benefits are categorized according to the services provided by the beneficial use. Categorization and calculation of benefits according to services provided is consistent with the valuation of ecological services (Boyd and Banzhalf, 2006) and allows for identification and calculation of separable components of total benefits, which may be added to water supply and water quality benefits calculated elsewhere.

The services provided by other beneficial uses of a water resources project generally result from the land-uses of the project area. A project area that consists of treatment wetlands may provide a different set of services than a project area that consists of a neighborhood park. For all water resources projects, the appropriate benefit measure is the difference between without and with-project conditions. Under this consideration, the benefits generated by a project that constructs 50 acres of new wetlands would be different from a project that preserves or enhances 50 acres of existing wetlands. The

benefits of the new wetland would be based on the full value of the services provided, but the benefits of the preserved or enhanced wetland would be based on the difference between services provided under the pre- and post-preservation (enhancement) conditions.

Land uses may be inclusive and overlapping. For example, parkland, open water, and wetlands may all be considered open space. Economic studies evaluating the benefits of open space often categorize the open space into more a more definitive sub-category for the purpose of evaluation (McConnell and Walls, 2005). In this benefits assessment framework, the benefits related to open space are evaluated based on the specific land use of the project area, such as wetland, parkland, etc., and the services provided by those land uses.

### **5.1 Project Related Land-Uses and Services**

The benefits of other beneficial uses of water resources projects are generated by the services provided by the beneficial uses. The services provided by the beneficial uses are generated by the specific land-use in the project area. The table below presents a simple matrix of common project related land-uses and the services they might provide. In this benefits assessment framework, these services, with the exception of flood control services<sup>2</sup>, will be evaluated based on values established in the environmental and natural resources literature (see discussion on benefit transfer, Section 5.2). For example, an open water retention area may provide habitat, recreation, aesthetic, and flood control services. The extent that any of these services is provided by a specific project must be either assessed through the project description or based on reasonable assumptions.

Land Use	Services Provided			
	Habitat	Recreation	Aesthetic	Flood Control
Wetlands	Yes	Yes	Yes	Maybe
Open Water	Yes	Maybe	Yes	Maybe
Riparian	Yes	Yes	Yes	Maybe
Parkland	No	Yes	Yes	No

The next few sections describe the ways that the services identified in the table above provide benefits and provides examples of benefit estimates found in the environmental and natural resource economics literature. These sections are preceded by a brief discussion of benefit transfer.

### **5.2 Benefit Transfer**

Benefit transfer is a non-market benefit estimation technique, which uses value estimates resulting from a pre-existing valuation study (study area) in the valuation of a resource in a different area (policy area). The purpose of benefit transfer is to obtain reasonable value estimates without having to incur the expense and the time required to conduct an

<sup>2</sup> Flood control benefits require more site specific information than would be found in the literature. Flood control benefits will largely be calculated using the flood control benefits model developed by LA County, based on information contained in the project description and reasonable assumptions.

original study for the policy area. Benefit transfer has been used extensively in the evaluation of water resource projects and has been the subject of much research by environmental and natural resource economists (see discussions and citations in USEPA 2000, Brower and Pearce 2006, and Young 2005 for example). In this benefits assessment framework, benefit transfer using simple point transfer methods will be used to obtain value estimates that will be appropriate for the formulation of a county-wide water resources plan that will be comprised of multiple local and regional projects. Benefit transfer using simple point transfer methods is less suitable for individual project justification.

Other benefit transfer methods, such as value function transfer based on a meta-data set of existing valuation studies, typically provide better value estimates but require more information concerning the policy area than will be available for this analysis. It may be possible to improve the quality of the benefit transfer for any project, if there is sufficient policy area data that would inform the study area selection. The selection of study area value estimates from the existing literature may be improved for the services discussed below, if data concerning policy area characteristics, such as median house values, housing density, and adjacent land uses were available. The following sections concerning the various services provided by the policy area identify the types of data that would support improved point transfer.

### **5.3 Habitat Services**

Habitat services, such as provision of spawning, feeding, and foraging areas would be provided by land uses such as wetlands, riparian areas, and open water areas. The economic values of habitat services are dependent on the species involved and in the availability of substitute habitat. Habitat values are therefore often unique and difficult to transfer from one site to another. In addition, there are few studies that calculate habitat related benefits in a way that isolates that component of benefits from other aspects of the area in question. However, in their review of open space valuation studies McConnell and Walls (2005) found that bird and fish habitat were among the most important services that contribute to wetland value.

In this benefits assessment framework, it is assumed that the value of habitat services is incorporated into the wetland, riparian, and open water values found in the literature and cannot be identified as a separable element. Similarly, the value of habitat services may also be included in value estimates for some recreation activities including fishing and bird watching. Therefore, the potential for double counting benefits would be increased if habitat values, overall wetland (or riparian area) values, and recreation values (fishing and bird watching) were considered separable elements.

### **5.4 Recreation Services**

Land uses associated with water resources projects in the GLACO region including wetlands, riparian areas, and parkland are expected to provide recreational services to the surrounding population. Recreational opportunities associated with open water land use may be limited due to the storage purpose and pool duration. Valuation studies of wetland recreation typically include fishing, bird hunting, and bird watching as the

recreation activities evaluated (see for example Brander et al 2006 and Bell 1996). Similarly, valuation studies of forest area recreation typically focus on the values of hunting and bird watching (see, for example, USFW studies). For the purpose of this benefits assessment framework, the recreational opportunities provide by wetlands and riparian areas are assumed to be the same. This assumption is based on the expectation that riparian areas would be developed adjacent to wetland areas and that the riparian areas would typically be a fringe around a larger open water and/or wetland area. In addition, the most important recreational opportunity, which will be the source of value used in this framework, is assumed to be bird watching, which is conducted in both wetland and riparian areas.

Wildlife watching is an enormously popular activity conducted by more than 66 million people nation wide (USFWS 2003). In 2001, 3.7 million California residents conducted bird watching in their home state on 303 million viewing-days. That same year 358 thousand out-of-state residents conducted bird watching in California on 1.8 million viewing-days. Ninety-three percent of California resident viewing-days were conducted within one mile of the participant's home (DOI et al. 2001). In their analysis of wetland valuation studies, Woodward and Wui (2001) found that wetlands which provide bird watching opportunities were valued more highly than the average wetland in their data set of valuation studies. McConnell and Walls (2005) include Woodward and Wui's analysis in their review of open space valuation studies. McConnell and Walls present a value of \$1,205/acre for the average wetland contained in Woodward and Wui's analysis, and a value of \$1,597/acre for wetlands that provide bird watching opportunities. These values represent an annual willingness-to-pay in 2005 dollars.

In this benefits assessment framework, \$1,597/acre (adjusted to 2006 dollars) will be used as the economic benefit for recreational services provided by wetlands and/or riparian areas constructed as a component of a water resources project. The potential benefits of other services provided by wetlands and riparian areas, such as aesthetic and flood control services, will be discussed in succeeding sections.

The economic benefits associated with parklands are typically evaluated through a hedonic pricing analysis, which uses data on local home sales to infer a value for neighborhood amenities such as parkland, natural areas, and other variations of open space. In a hedonic pricing analysis, the purchase price of a home is assumed to be the sum of the value of the individual characteristics of the house, property, and neighborhood. House characteristics include square footage, number of bed rooms, number of bathrooms etc., property characteristics include lot size, landscaping, etc., and neighborhood characteristics include schools and other neighborhood amenities such as parks. Parkland-related characteristics may include proximity to parkland, type of parkland, and use. The influence of parkland-related characteristics on housing prices is an indication of the home owner's willingness-to-pay for those characteristics.

Crompton (2005) presents a review of urban parkland valuation studies conducted since the 1980's. His analysis indicates that major determinants of parkland influence on housing prices include: proximity to a park, availability of recreational substitutes, and

type of park, such as a neighborhood park (active use) or natural area (passive use). In general, homes within a three to five minute walk of a park, homes in areas with fewer substitutes, and homes near parks with natural areas have higher prices than houses without these neighborhood characteristics. His review of existing studies shows a broad range of values for urban parkland, which are sensitive to variations in the characteristics identified above and other neighborhood characteristics.

Although Crompton (2005) shows that parkland values vary widely, he recommends that a 20% premium on a single family home value is a reasonable assessment of the influence of a passive use park that abuts or fronts a single family home. The influence on housing prices diminishes out to 600 feet for passive use parks, but extends out to 1,500 feet for neighborhood parks (Crompton 2005). The median price of a single family home in LA County is \$540,000 (Data Quick Real Estate News, 08May05). If this home were across the street from a passive use park the influence on the price of the home would be \$108,000 ( $\$540,000 * 20\%$ ).

One approach to assessing the value of parkland would be to use Compton's generalized distances to identify the number of homes whose prices are influenced by the local parkland, assume a linear rate of influence diminishment, and sum the price impact on the individual properties. If land use information indicating lot size and land use designations (residential, commercial, etc.) is available, then approximations of the value of parkland created by a water resources project may be estimated. It is important to note that this method does not capture the full economic benefit of creating new parkland because it does not account for multi-family housing units and benefits that may accrue to commercial properties (Crompton, 2005). Nonetheless, the addition of parkland value to the benefits assessment framework may be useful in the assessment of alternative beneficial uses.

## **5.5 Aesthetic Services**

Aesthetic services define a category of services provided by water resources projects, which do not require direct use of the project area. One aspect of aesthetic services is non-use services. Non-use services may include the knowledge that the resources exist, the option to use the resources in the future, or the assurance that the resources will be available for use by others (in current and/or future times). In addition to non-use services, the aesthetic services category is intended to capture the economic benefits of improvements to the project area that aren't captured in the recreation and flood control service categories.

For the purpose of this benefits assessment framework, the benefits of aesthetic services will be calculated for wetlands and the wetland value will be assumed to also represent the value of riparian area aesthetic services. Aesthetic services values may exist for open water and parkland project areas, but they will not be assessed in this analysis. The economic and natural resources literature includes numerous examples of wetland valuation studies that identify values that are not directly (or specifically) related to recreation or flood control (see Brander 2006 and Woodward and Wui 2001). Numerous

hedonic pricing studies have identified positive values for wetlands as a neighborhood characteristic (see Brander 2006, Woodward and Wui 2001, and McConnell and Walls 2005 for example). Study area characteristics that typically increase the value of wetlands include being in an urban or suburban location (Brander 2006), lack of substitutes (Pate and Loomis 1997), and the type of wetland being emergent or inclusive of open water (Doss and Taft 1996).

An important study of wetland values in California was conducted by Pate and Loomis (1997) concerning wetlands in the San Joaquin valley. In their analysis respondents were asked how much they would be willing to pay to improve wetlands in the San Joaquin valley based on the anticipated outcomes of various restoration projects. The survey was distributed to California residents and residents of Nevada, Oregon, and Washington. San Joaquin valley residents were willing to pay \$216 in annual taxes per household for restoration of valley wetlands. The willingness to pay decreased as distance from the valley increased. Availability of substitute wetlands was also included as an explanation for lower values from Oregon.

California residents outside of the San Joaquin valley exhibited a willingness to pay of \$211 and Nevada residents exhibited \$196. The California value is based on 577 responses but the Nevada sample however, consists of only 21 respondents. The willingness-to-pay expressed by California residents living outside of the San Joaquin valley is based largely on aesthetic services as defined above. Although some respondents are likely to use the area for bird watching or other recreation, it is reasonable to expect that most respondents are not regular users of the area.<sup>3</sup> Also, the respondents living outside of the valley are not the direct beneficiaries of the flood control services provided by the wetlands in question.

In this benefits assessment framework, the \$211 willingness to pay expressed by California residents living outside of the San Joaquin valley is used to represent the value of aesthetic services provided by wetlands constructed for water resources projects in the GLACO region. Pate and Loomis (1997) identify 90,000 acres of wetlands in the San Joaquin valley. The aggregate value of non-valley California residents was calculated by Pate and Loomis as \$2,357 million (11.18 million households \* \$211). The equivalent per acre value is \$26,188 per acre. In order to put this per acre value into perspective consider the analysis conducted by Farber (1996) which estimated the economic value of Louisiana wetlands based on recreational, storm protection, water quality, and water supply perspectives. Farber (1996) estimates the per acre value of Louisiana wetlands (approximately 3 million acres existed during the time of the study) as ranging between \$8,437 and \$15,763. He considered this range a minimum value estimate because aesthetic and other services were not accounted for in his analysis.

---

<sup>3</sup> An important caveat is required here. There may be strong self selection bias in the responses to the survey instrument. In other words, it may be possible that a disproportionate amount of respondents are regular users of the area because they are the ones who took the trouble to respond.



## **5.6 Flood Control Services**

Flood control services may be provided by wetlands, riparian areas, and open water areas constructed as a part of the water resources project. The calculation of benefits resulting from flood control services is a data intensive exercise that consists of establishing an inventory of structures within the floodplain, establishing depth-damage relationships that identify the value of damages for alternative flood depths, and establishing the damage-frequency relationship, which expresses the probability of experiencing alternative flood depths and the associated damages. Damages must be calculated for the without and with-project conditions with the difference being the benefits of the flood control services provided by the project (see Young 2005 and USACE 1998).

This level of information is not expected to be available for most projects to be included in the IRWMP. However, the flood control component of the LA County Watershed Management Techniques Economic Valuation Model (County of Los Angeles 2005) will be used to estimate flood control benefits, if information is available to populate the model. In addition, cumulative flood control services resulting from all projects identified in the IRWMP may provide a level of flood protection that reduces the damage-frequency relationships established for Corps of Engineers projects on the San Gabriel and Los Angeles rivers. The cumulative flood control impact of all IRWMP projects will be reviewed against these regional flood control benefit studies to determine if regional flood control benefits can be calculated.

### **5.6.1 Other Beneficial Use Benefits Example Application**

An example of the estimation of other beneficial use benefits, consider the storm water capture and treatment project that was used as an example for water supply and water quality benefits. This project includes a retention basin, some constructed wetlands, and a spreading area for groundwater recharge. This project provides 1,000 acre-feet per year of additional groundwater recharge, 2,500 acre-feet of storm water treatment, and 12 acres of constructed wetlands.

The other beneficial use benefits of the 12 acres of constructed wetlands are based on the recreational and aesthetic services provided by the wetland. The benefits related to recreational services are \$19,164 (12 acres \* \$1,597/acre). The benefits resulting from aesthetic services provided by the 12 acres of wetland are \$314,256 (12 acres \* \$26,188/acre). The total other beneficial use benefits resulting from this project are \$333,420.

## **6 Total Project Benefits**

The total benefits resulting from each of the IRWMP projects are the sum total of the water supply, water quality, and other beneficial use benefits identified in this benefits assessment framework. Each benefit category was identified and calculated as a separable element of benefits so that the summation of these elements would avoid double counting. The preceding sections have identified and calculated benefits related

to a hypothetical project which provides 1,000 acre-feet per year of additional groundwater recharge, 2,500 acre-feet of storm water treatment, and 12 acres of constructed wetlands.

The water supply benefits of this project are estimated to be \$1,299,800. The water quality benefits are estimated as \$1,410,000 and the other beneficial use benefits are \$333,420. The total economic benefit of this project based on the concept of economic value expressed through willingness-to-pay is \$3,043,220.

## **7 Framework Examples from Step 2 Application Projects**

This section of the benefits assessment framework provides examples of use of the benefits framework in three projects within the Step 2 Applications currently being submitted by LA County. The benefits that would be generated by these three projects are discussed below. These projects include the

- Joint Water Pollution Control Plant (JWPCP) Marshland Enhancement Project (Project #2),
- Large Landscape Water Conservation, Runoff Reduction, And Educational Project (Project #3), and
- Eighth Street Park – Pacoima Wash Greenway Project (Project #8).

This section is organized as follows. Each sub-section presents brief project descriptions followed by a description of the benefits and their calculations. Project costs are presented for comparison to the monetized project benefits. It is important to consider that the total benefits of water resources projects are often greater than the benefits that can be reasonably monetized. Benefits cost ratios represent only monetized benefits and therefore should not be used as the sole determinant of project viability for water resources projects.

### **7.1 JWPCP Marshland Enhancement Project**

The Joint Water Pollution Control Plant (JWPCP) Marshland Enhancement Project will restore and enhance a total of 17 acres of wetlands in an urban area. The marshland will support open water, wetland, riparian, scrub, and upland habitats in addition to providing contaminant removal, flood protection, use of recycled materials, a storm water control swale, and education and recreation opportunities.

The project will reduce pollutant loading into the Wilmington Drain. TMDL constituents for the Wilmington Drain include ammonia, copper, lead, and coliform. Other constituents likely present in the Wilmington Drain that will be reduced include arsenic, cadmium, chromium, nickel, selenium, zinc, BOD, total nitrogen, total phosphorus, suspended solids, and volatile organic compounds.

The approximate flow rate expected through the marshland is 2 mgd (1,700 afy). A removal rate of 20 percent is expected for the constituents listed above based on the results published in the Assessment of BMP Effectiveness (Attachment 8, Reference 2-6). The percent decrease in samples from the marshland inlet and outlet will be calculated for those constituents that are consistently detected above the detection limits to confirm removal rates achieved.

The benefits generated by the project include

- 1,700 acy of storm water treatment at 20% effectiveness,
- 17 acres of created/restored wetland habitat;
- Recreation opportunities (bird watching) at the 17 acres of created/restored habitat;
- Development of community amenities in a disadvantage community; and
- 8.8 ac ft of additional flood control storage.

The economic benefits related to development in a disadvantaged community and additional flood control storage have not been quantified in a dollar metric for this analysis. The dollar values for the remaining three benefit types are presented below. The benefits have been calculated for each of 50 years starting in 2006. The benefits reflect that 2008 is the first year benefits begin to accrue and that full growth (and thereby full benefits) doesn't occur until 2012.

The water quality benefits resulting from 1,700 acre feet of partial treatment are based on the unit value for water quality improvement (\$564/ac ft) as discussed in Section 4.3.2 of the Benefits Assessment Framework. After accounting for the 20% percent treatment effectiveness the per acre foot value is reduced to \$113. The annual value at 1,700 acre feet is \$191,760. The discounted sum of present values for water quality benefits is \$2,367,336 calculated at 6% over 50 years.

The 17 acres of wetlands created and restored under this project provide aesthetic services and recreation opportunities. The value of aesthetic services provided by wetlands (\$26,188/acre) is discussed in Section 5.5 of the Benefits Assessment Framework. The annual value of aesthetic services provided by 17 acres is \$445,196 and the discounted sum of present values is \$5,496,081. One of the most important recreation opportunities provided by wetlands and riparian areas is bird watching. A review of the environmental and natural resource literature resulted in a per acre value of \$1,597 for bird watching opportunities provided by wetlands (Section 5.4). The annual value of bird watching at the 17 acre wetland is \$27,149, with a resulting discounted present value of \$335,163. The following table summarizes the economic benefits calculated for the JWPCP Marshland Enhancement Project.

JWPCP Marshland Enhancement Project Monetized Benefits		
Benefit Type	Annual Benefits	Sum of Discounted Present Values
Water Quality Improvement	\$191,760	\$2,367,336
Wetland Aesthetic Services	\$445,196	\$5,496,081
Wetland Bird Watching	\$27,149	\$335,163
Community Development	unknown	unknown
Flood Protection	unknown	unknown
Totals	\$664,105	\$8,198,580

The total present value of discounted costs for this project is \$4,510,140 calculated at 6% over 50 years. This cost includes \$2,637,065 in capital costs and \$150,000 in annual O&M costs.

## **7.2 Large Landscape Water Conservation, Runoff Reduction, And Educational Project**

The large landscape water conservation, runoff reduction, and educational project will evaluate and implement a large landscape water management program utilizing centralized weather-based irrigation controllers and computer management system that link back to the local water and regional agencies regarding end-use water management. The program is designed to allow the local users (parks, schools, cities, etc.) to work with a water management company, Hydroearth, that utilizes the HydroEarth Water Management System. Participants will be provided with centralized irrigation controllers and management tools to aid in the protection of the local watershed.

The program will also provide an accountability documentation trail that will show water reduction and urban runoff data. The project will include large landscapes and other areas that contribute to high water usage and runoff pollution. The targeted landscape sites will include large landscapes, schools, parks, home owner associations, business parks, facility landscapes, street medians, and residential sites over 1,500 square feet that are the top water users in the area.

The primary objectives of this project are to increase water supply reliability, improve water quality, conduct public educational workshops and develop water efficient demonstration gardens to increase public awareness. By developing this integrated approach, the various stakeholders will work together to meet the objectives of the project.

The project will have several components. The first component of the project is to target large landscape sites of 1 acre and greater. Centralized irrigation controllers will be provided with the goal of conserving 1 afy of water for each acre of land and to reduce urban runoff as a result. Through the installation and management of landscape weather-based irrigation controllers, an estimated 20 to 50 percent of irrigation water will be conserved, thus reducing imported water needs. Also, up to 70 percent of water runoff

will be reduced at the targeted areas by using proven scientific irrigation methods. There is also an Area of Special Biological Significance (ASBS) within this Region that the project will positively impact.

The second component of the Project is to target the top residential water users in the region. A total of 2,700 rebates will be provided to residential customers to help customers purchase and install "smarter" residential controllers. Each irrigation controller can range from \$300 to \$700. Most of the residential weather-based irrigation controllers use built-in or on-site weather data.

The third component of the Project will be to develop and provide the residential landscape workshops for the residents and business owners. WBMWD has formed a partnership with the Surfrider Foundation to develop and offer "Ocean Friendly Garden" workshops. The Surfrider Foundation is an environmental organization dedicated to restoring and protecting coastal and marine ecosystems. The workshops will be multi-faceted and provide information on various subjects including: weather-based irrigation controllers (rebates), native plants, garden designs, irrigation system "tune-ups" and also provide information on the state's water supply and water quality issues. In addition to the workshops, there will be several "Ocean Friendly" demonstration gardens throughout the watershed for those areas along the Santa Monica Bay within WBMWD's service area. Through the workshops, participants will learn about the gardens, which will encourage participants to develop their own "Ocean Friendly Garden." The gardens will provide "real-life" examples of the plants and irrigation systems that will be taught in the workshops. The workshops will provide a unique mechanism necessary to disseminate information regarding the program and to increase public awareness about the water supply and water quality issues. The workshops will help gain public acceptance of the program to help ensure its success.

The last component of the project will be to conduct landscape workshops for those areas located within Central Basin service area. These landscape workshops will be developed and conducted by CBMWD, in coordination with the cities and local stakeholders, to teach people about planting native species and ways to conserve water outdoors.

In addition, CBMWD, in coordination with cities and stakeholders, will develop five demonstration gardens to be located throughout the Region. The gardens will be used in conjunction with the landscape workshops to educate the public about water-efficient gardening and irrigation systems and to encourage the public to develop their own water-efficient gardens.

This project generates water supply and water quality benefits. The water supply benefits are based on conservation of 1,625 acre feet of water supply each year. This level of conservation will be achieved in the fourth year of operation with build-up occurring during the first four years. The water quality benefits are based on the runoff reduction resulting from lawn irrigation conservation. Runoff reduction is assumed to be equivalent to 25% of the conservation total. The project will begin accruing benefits in 2009 and will achieve full annual benefits in 2013.

Water supply benefits are based on the avoided cost of imported supply and the value of reliability as described in section 3.3 of the Benefits Assessment Framework. Avoided costs and shortage surcharges are based on the average rate calculated for the low and high rate projections. The shortage surcharge has been calculated at the greater than 102% allocation rate (three times the average Full Service Tier 1 rate). The shortage surcharge is reduced to reflect the dry year probability (30%), which indicates that the shortage surcharge may be applicable 3 out of every 10 years. Overall, the discounted sum of present value water supply benefits resulting from this lawn irrigation conservation project (1,625 ac ft per year) is \$31,790,472. The following table presents water supply benefits per acre foot for selected years.

Water Supply Benefits for Selected Years (\$/ac ft)				
Year	2010	2015	2020	2025
Benefit	\$1,098	\$1,244	\$1,410	\$1,599

Water quality benefits are calculated using the same benefit per acre foot (\$564) as used in the JWPCP Marshland Enhancement Project. The discounted sum of present value water quality benefits resulting from runoff reduction equivalent to 25% of conservation is \$2,681,628. The total discounted sum of present value benefits for this conservation project is \$34,472,100.

The total discounted present value of project costs is \$11,165,118, which includes \$5,291,360 in capital costs and the remainder consisting of annual O&M and administrative costs.

### **7.3 Eighth Street Park – Pacoima Wash Greenway**

The planned Pacoima Wash Greenway, is a 3-mile long corridor of natural open space that will protect the land and water resources of the watershed. One of the goals of the greenway is to capture all storm water runoff from stream channel-adjacent neighborhoods for treatment and infiltration in BMPs integrated into a series of parks along the Pacoima Wash channel.

The greenway will extend from the Angeles National Forest and the Rim of the Valley Trail Corridor to the communities of the northeast San Fernando Valley. Subject of this proposal is a small project component of the larger plan. The project site is located on the north side of the Pacoima Wash between Foothill Blvd. and 8<sup>th</sup> Street in the City of San Fernando. It is proposed to convert approximately 3 acres of undeveloped land into a natural park that collects, treats and infiltrates residential runoff onsite.

The project will provide an estimated 10 afy of storm water and urban runoff treatment annually, thereby reducing pollutant loading in the groundwater and waterways located downstream of the project including the Los Angeles River and the Pacific Ocean.

Key pollutants that will be reduced include trash, sediments, and a substantial portion of grease, oils, and heavy metals. The project will therefore help address the existing trash

TMDL for the Los Angeles River, as well as the bacteria and metals TMDLs, which are currently under development. The water quality benefits will be realized upon completion of project construction in October 2007; however, quantification of the reduction in concentration or load of constituents cannot be calculated based on the data currently available for the project.

The 8<sup>th</sup> Street Park Project provides a variety of benefits that include:

- Water quality improvement;
- Natural park benefits;
- Aesthetic services from riparian habitat;
- Bird watching opportunities, and
- Development in a disadvantaged community.

Economic benefits have been calculated for each benefit type, with the exception of development in a disadvantaged community.

The water quality benefit is based on 10 acre feet of storm water treatment to be provided annually by the project. For the purpose of this analysis, treatment is assumed to be 100% effective. The natural park benefit is based on analyses found in the environmental and natural resource economics literature that calculate increases in residential property values due to proximity to natural parks (see section 5.1 of the Benefits Assessment Framework). The natural park proximity benefit is a one time benefit that is calculated as a 20% increase in the median home value for the City of San Fernando. This benefit was applied to 12 single family homes within 1,500 feet of the project. The benefits resulting from aesthetic services and bird watching are the same as those calculated for the JWPCP Marshland Enhancement Project. This analysis assumes similarity in value between the aesthetic services and bird watching opportunities of wetlands and those found in riparian habitats. The table below presents the economic benefits calculated for the 8<sup>th</sup> Street Park Project.

Eighth Street Park Project Monetized Benefits		
Benefit Type	Annual Benefits	Sum of Discounted Present Values
Water Quality Improvement	\$5,640	\$78,583
Natural Park Proximity	One time benefit	\$880,336
Riparian Aesthetic Services	\$78,564	\$1,094,642
Riparian Bird Watching	\$4,791	\$66,754
Community Development	Unknown	Unknown
Totals	\$88,995	\$2,120,314

The total discounted present value sum of costs for the Eighth Street Project is \$2,315,782. The capital cost component of total cost is \$1,328,650 and annual O&M is \$80,000.

## 8 References

In progress





City of Los Angeles - MASTER LAND USE PERMIT APPLICATION

For Office Use Only

Envirn. Clear. No. CE 99-0989

Existing Zone. \_\_\_\_\_

District Map No. \_\_\_\_\_

Council District \_\_\_\_\_

Planning Area \_\_\_\_\_

Census Tract No. \_\_\_\_\_

Assessor's Parcel No. \_\_\_\_\_

**ZA 990828**

(ZAI)

Case No. \_\_\_\_\_

Type of Application Submitted (zone change, variance, etc.) \_\_\_\_\_

Zoning Administrator Interpretation of Land Uses \_\_\_\_\_

1. PROJECT LOCATION AND SIZE

Street Address of Project GRIFFITH PARK WATER SYSTEM REPLACEMENT PROJECT

Legal Description: 3601 Vista Del Valle Dr, Los Angeles, CA 90027  
Por. of Ro. Los Feliz, Sec 19, 30, 31, T1N, R13W; Sec 6, T1S, R13W;

Sec 24, 25, 36, T1N, R14W; Sec 1, T1S, R14W, all S.B.M./P.1-164

Lot Dimensions N/A Lot Area (sq. ft.) N/A

Total project size (sq. ft.) N/A

2. PROJECT DESCRIPTION

Describe what is to be done: Construct six Water Tanks and eight Pump Stations  
(See attached Tables 1 and 2)

Present Use: Supply water for Fire and Domestic uses.

Proposed Use: SAME

Plan Check No. (if available) CC9544 Date Filed: 07/01/1999

Please check all the following that apply -----

New Construction  Change of Use  Alterations  Demolition

Commercial  Industrial  Residential

Additions to a building - Rear  Front  Height  Side Yard

3. ACTION(S) REQUESTED (include City Code Section which authorizes actions or Code Section from which you are seeking a variance or exemption)

Code Section: OTHER USES DETERMINED BY THE ADMINISTRATOR

PLANNING AND ZONING CODE SECTION 12.21,A,2

List case numbers of any other pending or recent applications relating to this site

Zip: \_\_\_\_\_ Fax: ( ) \_\_\_\_\_

**6. APPLICANT'S AFFIDAVIT**

Under penalty of perjury the following declarations are made:

- a: The undersigned is the owner or lessee if entire site is leased; or authorized agent of the owner with power of attorney or officers of a corporation (submit proof). (NOTE: for zone changes lessee may not sign).
- b: The information presented is true and correct to the best of my knowledge.

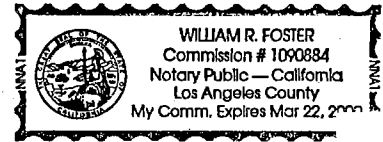

Signed: Stephen E. Klippel  
Record Owner only

Date: 9/29/99

STEPHEN E. KLIPPEL  
Print Name of Owner in Full

William R. Foster  
Notary Public

**7. ADDITIONAL INFORMATION/FINDINGS**

In order for the City to render a determination on your application, additional information may be required. Consult the appropriate "Special Instructions" handout. Provide on an attached sheet(s), this additional information using the hand-out as a guide.

**NOTE:** All applicants are eligible to request a one time, one-year only freeze on fees charged by various City departments in connection with your project. It is available only when this application is deemed complete or upon payment of Building and Safety plan check fees. Please ask staff for details or an application.

**FOR OFFICE USE ONLY**

Reviewed and Accepted by [Signature] Date: 9/30/99 Base Fee \_\_\_\_\_

Receipt No. [Signature] Deemed Complete by: [Signature] Date: 9/30/99

# NOTICE OF EXEMPTION

(Article III, Section 3 — City CEQA Guidelines)

Submission of this form is optional. The form shall be filed with the County Clerk, 111 No. Hill St., Los Angeles, California 90012, pursuant to Public Resources Code Section 21152(b). Pursuant to Public Resources Code Section 21168(d), the filing of this notice starts a 35-day statute of limitations on Court challenges to the approval of the project. Failure to file this notice with the County Clerk results in the statute of limitations being extended to 180 days.

LEAD CITY AGENCY: **Los Angeles City Planning Dept.** COUNCIL DISTRICT: \_\_\_\_\_

PROJECT TITLE: **Griffith Park Water System Replacement** LOG REFERENCE: **CE 99-0889**

PROJECT LOCATION: **Various sites -**

DESCRIPTION OF NATURE, PURPOSE, AND BENEFICIARIES OF PROJECT:  
**Construct six water tanks & 8 pump stations to supply water for five domestic use**

NAME OF PERSON OR AGENCY CARRYING OUT PROJECT, IF OTHER THAN LEAD CITY AGENCY:  
**Department of Rec & Parks**

CONTACT PERSON: **Martin Adams** AREA CODE: **213-** TELEPHONE NUMBER: **367-0864** EXT.: \_\_\_\_\_

EXEMPT STATUS: (Check One)		
	CITY CEQA GUIDELINES	STATE EIR GUIDELINES
<input type="checkbox"/> MINISTERIAL	Art. III, Sec. 2b	Sec. 15073
<input type="checkbox"/> DECLARED EMERGENCY	Art. III, Sec. 2a(1)	Sec. 15071(a)
<input type="checkbox"/> EMERGENCY PROJECT	Art. III, Sec. 2a(2) & (3)	Sec. 15071(b) & (c)
<input type="checkbox"/> GENERAL EXEMPTION	Art. III, Sec. 1	Sec. 15060
<input checked="" type="checkbox"/> CATEGORICAL EXEMPTION	Art. VII, Sec. 1	Sec. 15100
Class <u>1</u> Category <u>22</u> (City CEQA Guidelines)		
<input type="checkbox"/> OTHER (See Public Resources Code Sec. 21080(b) and set forth state and city guideline provision.	_____	

JUSTIFICATION FOR PROJECT EXEMPTION: **Granting or renewal of a variance or conditional use for a nonsignificant change of use in an existing facility.**

IF FILED BY APPLICANT, ATTACH CERTIFIED DOCUMENT OF EXEMPTION FINDING.

SIGNATURE: **[Signature]** TITLE: **So City Planner** DATE: **9/20/99**

FEE: **[Signature]** RECEIPT NO.: \_\_\_\_\_ REC'D BY: **[Signature]** DATE: **at-aloo**

ZA 990828 (BAI)

**TABLE 1 - TANKS**  
**GRIFFITH PARK WATER SYSTEM REPLACEMENT PROJECT**

Tank Name	Address	Figure	Schedule Start	Schedule Finish	Dimension Diameter (feet)	Dimension Height (feet)	Capacity (Gallons)	Construction Materials	Replaces Existing Park Facilities	Purpose
P1-1	3601 Vista Del Valle Dr.	2 & 3	Nov-99	Jun-00	64	34	750,000	Steel	Tanks 114 & 115	Provides regulatory and fire supply for the south end of Griffith Park. Facilities include the Greek Theatre, Roosevelt Golf Course and adjoining tennis courts, the bird sanctuary, nursery and Coolidge Golf Course. It also includes interim fire supply to the Observatory until Phase 4 is completed.
P2-1	5180 Mt. Hollywood Dr.	4 & 5	Jun-00	Dec-01	66	42	1,000,000	Steel	Tanks G, 71, 73, 75, 111 & 112	Provides regulatory and fire supply for north end of Griffith Park. Facilities include Travel Town, the Equestrian Center, the Los Angeles Zoo, and suction supply for Toyon Landfill and the Helispot.
P3-1	5111 North Trail	6 & 7	Jun-00	Oct-02	66	42	1,000,000	Steel	Tanks G, 71, 73, 75, 111 & 112	Provides regulatory and fire supply for the east side of Griffith Park. Facilities include the Los Angeles Zoo, Autry Museum, L.A. Unified magnet school, Wilson and Harding Golf Courses, two Ranger headquarters, major picnic, ball field, and turf areas at Park Center, Crystal Springs Picnic Area, and Ferraro Fields.
P4-1	4651 Vista Del Valle	8 & 9	Apr-03	Jan-05	66	42	1,000,000	Steel	Tank 112 & 113	Provides regulatory and fire supply for the center and west side of Griffith Park. Facilities include Mt. Hollywood helispot, Mineral Wells, long-term supply to the Griffith Observatory, and smaller garden and irrigated areas.
P4-2	4481 Mt. Hollywood Dr.	10 & 11	Jan-03	Jan-04	66	42	1,000,000	Steel	Tanks 151, 152 & 153	Provides regulatory and fire supply for the center and west side of Griffith Park. Facilities include Toyon landfill and helispot, Mt. Hollywood helispot, Mineral Wells, long-term supply to the Griffith Observatory, and smaller garden and irrigated areas.
P4-3	4100 Mt. Hollywood Dr.	12 & 13	Jan-01	Jan-03	15	40	50,000	Steel	Tank 151	Provides fire supply for Mt. Hollywood helispot.

**PLANS APPROVED**  
as required by

Case No. 2009-0828 (BAI)

Robert Janovick  
CHIEF ZONING ADMINISTRATOR  
CITY OF LOS ANGELES

Date 8-20-09

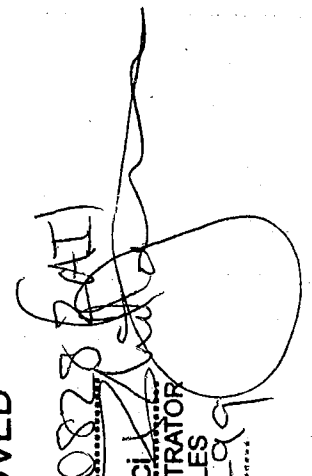

# ZA 990828

**PLANS APPROVED**

as required by

Case No. **ZA 99-0828 (2A)**

**Robert Janovick**  
 CHIEF ZONING ADMINISTRATOR  
 CITY OF LOS ANGELES

Date **9-30-99**

**TABLE 2 - PUMP STATIONS**  
**GRIFFITH PARK WATER SYSTEM REPLACEMENT PROJECT**

Pump Stations	Address	Figure	Schedule Start	Schedule Finish	Dimension Length (feet)	Dimension Width (feet)	Capacity GPM	Construction Material	Replaces Existing Park Facilities	Purpose
Pump Station 1	3900 Vermont Canyon Rd.		Apr-00	Apr-01	50	25	2000	Masonry	Tanks 151, 152 & 153, Pumps 73, 111, 112, 113, & 114	Provides interim fire supply to the Observatory until Phase 4 is completed. Backup regulatory and fire supply for the Observatory when Phase 4 is completed.
Pump Station 2	5350 Zoo Dr.	14 & 15	Jan-01	Oct-01	80	55	9000	Masonry	Pumps G, 73, 74, 75, Crystal Springs, Travel Town & Zoo Pump Stations	Provides regulatory and fire supply for north and east sides of Griffith Park. Facilities include Toyon Landfill and Helispot, Travel Town, the Equestrian Center, the Los Angeles Zoo, Autry Museum, L.a. Unified magnet school, Wilson and Harding Golf Courses, two Ranger headquarters, major picnic, ball field and turf areas at Park Center, Crystal Springs Picnic Area, and Ferraro Fields.
Pump Station 3	4290 Crystal Springs Dr.	16 & 17	Jul-01	Apr-02	80	55	9000	Masonry	Pumps G, 73, 74, 75, Crystal Springs, Travel Town & Zoo Pump Stations	Provides regulatory and fire supply for north and east sides of Griffith Park. Facilities include Travel Town, the Equestrian Center, the Los Angeles Zoo, Autry Museum, L.a. Unified magnet school, Wilson and Harding Golf Courses, two Ranger headquarters, major picnic, ball field and turf areas at Park Center, Crystal Springs Picnic Area, and Ferraro Fields.
Pump Station 4	5111 North Trail	6 & 7	Apr-02	Jan-03	50	25	2000	Masonry	Zoo Pump Station	Provides regulatory and fire supply for the north and east sides of Griffith Park. Boosts the hydraulic grade from the existing Zoo Tank to the existing Toyon Tank. Facilities include the Toyon Landfill and Helispot, the Boys Camp and the Los Angeles Zoo.
Pump Station 5	5111 North Trail	6 & 7	Apr-04	Jan-05	50	25	2000	Masonry	Tanks 151, 152 & 153, Booster Pumps 73, 111, 112, 113, & 114	Provides regulatory and fire supply for the center and west side of Griffith Park. Facilities include Toyon landfill and helispot, Mt. Hollywood helispot, Mineral Wells, long-term supply to the Griffith Observatory, and smaller garden and irrigated areas.
Pump Station 6	5180 Mt. Hollywood Dr.	4 & 5	Jan-03	Jan-04	50	25	2000	Masonry	Tanks 151, 152 & 153, Booster Pumps 73, 111, 112, 113, & 114	Provides regulatory and fire supply for the center and west side of Griffith Park. Facilities include Toyon landfill and helispot, Mt. Hollywood helispot, Mineral Wells, long-term supply to the Griffith Observatory, and smaller garden and irrigated areas.
Pump Station 7	4651 Vista Del Valle	8 & 9	Jan-03	Jan-04	50	25	2000	Masonry	Tanks 151, 152 & 153, Booster Pumps 73, 111, 112, 113, & 114	Provides regulatory and fire supply for the center and west side of Griffith Park. Facilities include Toyon landfill and helispot, Mt. Hollywood helispot, Mineral Wells, long-term supply to the Griffith Observatory, and smaller garden and irrigated areas.
Pump Station 8	4481 Mt. Hollywood Dr.	10 & 11	Jan-03	Jan-04	50	25	2000	Masonry	Tanks 151, 152 & 153, Booster Pumps 73, 111, 112, 113, & 114	Provides fire supply for Mt. Hollywood helispot.

**APPROVED BY THE ADMINISTRATOR**  
**Planning Code Section 12.21, A, 2**

**MOD PLANS**

**GILLIS**

**PERSON: ARTURO A. ANGELES**

**3-367-0809**

- 5, 153B193, 153B197, 154.5A201, 154.5A03
- 56B193, 156B197, 156B201, 157.5A189
- 159B193, 159B197, 159B201, 162B193
- 35B193, 165B197, 165B201, 168B189
- 38B201



**CITY OF LOS ANGELES**  
**DEPARTMENT OF RECREATION & PARKS**

**TOPOGRAPHIC MAP OF**  
**GRIFFITH PARK**

SCALE: 1" = 500'



CONTOUR INTERVAL 5'

PURCHASE ORDER NO. 15982 DATED: MAY-12-1958

COMPILED BY STEREOPHOTOGRAMMETRIC METHODS  
BASED ON CALIFORNIA RECTANGULAR COORDINATE  
SYSTEM ZONE 7 AND ON MEAN SEA LEVEL

DATUM BY  
**SLOAN & ASSOCIATES INC.**  
ARCADIA CALIFORNIA

REVISED BY PAFFORD & ASSOCIATES  
LOS ANGELES, CALIFORNIA  
OCTOBER, 1972

**ZA 990828 (ZAI)**

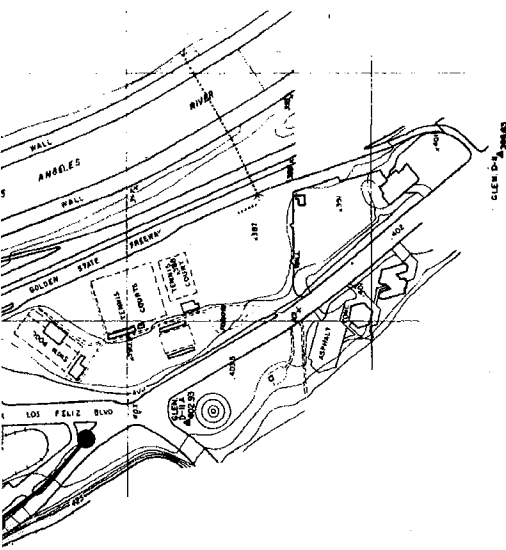

**PLANS APPROVED**

as required by

Case No. **ZA 99-0828 (ZAI)**

**Robert Jarovick**  
**CHIEF ZONING ADMINISTRATOR**  
**CITY OF LOS ANGELES**

Date **9/20/99**

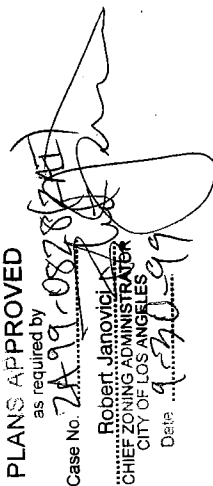



**OTHER USES DETERMINED BY THE ADMINISTRATOR**  
**Planning and Zoning Code Section 12.21, A, 2**

C.D. 4  
C.T. 1882  
P.A. HOLLYWOOD PLANS  
CASE NO. \_\_\_\_\_  
DATE: \_\_\_\_\_  
DRAWN BY: P. GILLIS  
D.M.: SEE LIST  
SCALE: 1"=500'  
USES: FIELD

T.B. PAGE 563, 564  
593, 594  
DWP CONTACT PERSON: ARTURO A. ANGELES  
PHONE NO. 213-367-0809

D.M.: 151.5A193, 151.5A195, 153B193, 153B197, 154.5A201, 154.5A03  
156A189, 156A191, 156B193, 156B197, 156B201, 157.5A189  
157.5A191, 156B189, 159B193, 159B197, 159B201, 162B193  
162B197, 162B201, 165B193, 165B197, 165B201, 168B189  
168B193, 168B197, 168B201

**Water Supply & Reuse**

Reporting Unit:  
**Los Angeles Dept. of Water and Power**

Year:  
**2007**

**Water Supply Source Information**

<b>Supply Source Name</b>	<b>Quantity (AF) Supplied</b>	<b>Supply Type</b>
LA Aqueduct	277942	Imported
MWDSC	295602	Imported
Groundwater	88906	Groundwater
Recycled	5186	Recycled
Transfer	1136	Imported
Storage	242	Imported

**Total AF: 669014**

Reported as of 6/10/10



**Accounts & Water Use**

Reporting Unit Name: **Los Angeles Dept. of Water and Power** Submitted to CUWCC **02/08/2009** Year: **2007**

What is the reporting year? Fiscal Month Ending June

**A. Service Area Population Information:**

1. Total service area population 4044080

**B. Number of Accounts and Water Deliveries (AF)**

Type	Metered		Unmetered	
	No. of Accounts	Water Deliveries (AF)	No. of Accounts	Water Deliveries (AF)
1. Single-Family	481908	261323	0	0
2. Multi-Family	123597	188149	0	0
3. Commercial	72130	114298	0	0
4. Industrial	6867	21838	0	0
5. Institutional	7403	48320	0	0
6. Dedicated Irrigation	745	248	0	0
7. Recycled Water	42	6509	0	0
8. Other	0	0	0	0
9. Unaccounted	NA	32080	NA	0
<b>Total</b>	<b>692692</b>	<b>672765</b>	<b>0</b>	<b>0</b>

Metered Unmetered

Reported as of 6/10/10

**BMP 01: Water Survey Programs for Single-Family and Multi-Family Residential Customers**

Reporting Unit: **Los Angeles Dept. of Water and Power** BMP Form Status: **100% Complete** Year: **2007**

**A. Implementation**

- 1. Based on your signed MOU date, 09/12/1991, your Agency STRATEGY DUE DATE is: 09/11/1993
- 2. Has your agency developed and implemented a targeting/marketing strategy for SINGLE-FAMILY residential water use surveys? **yes**
  - a. If YES, when was it implemented? 06/01/1990
- 3. Has your agency developed and implemented a targeting/marketing strategy for MULTI-FAMILY residential water use surveys? **yes**
  - a. If YES, when was it implemented? 06/01/1990

**B. Water Survey Data**

Single

<b>Survey Counts:</b>	<b>Family Accounts</b>	<b>Multi-Family Units</b>
1. Number of surveys offered:	12500	12500
2. Number of surveys completed:	5444	9913

**Indoor Survey:**

3. Check for leaks, including toilets, faucets and meter checks	yes	yes
4. Check showerhead flow rates, aerator flow rates, and offer to replace or recommend replacement, if necessary	yes	yes
5. Check toilet flow rates and offer to install or recommend installation of displacement device or direct customer to ULFT replacement program, as necessary; replace leaking toilet flapper, as necessary	yes	yes

**Outdoor Survey:**

6. Check irrigation system and timers	no	no
7. Review or develop customer irrigation schedule	no	no
8. Measure landscaped area (Recommended but not required for surveys)	no	no
9. Measure total irrigable area (Recommended but not required for surveys)	no	no
10. Which measurement method is typically used (Recommended but not required for surveys)		None
11. Were customers provided with information packets that included evaluation results and water savings recommendations?	no	no
12. Have the number of surveys offered and completed, survey results, and survey costs been tracked?	yes	no
a. If yes, in what form are surveys tracked?		database
b. Describe how your agency tracks this information.		

Contractor reporting & invoice support documentation

**C. "At Least As Effective As"**

1. Is your AGENCY implementing an "at least as effective as" variant of this BMP?	No
a. If YES, please explain in detail how your implementation of this BMP differs from Exhibit 1 and why you consider it to be "at least as effective as."	

**D. Comments**

Period: FY 06-07. Interior assessments with installation of devices as needed (ULFTs, showerheads, aerators, flappers). Direct and indirect marketing for MF segment

Reported as of 6/10/10

**BMP 02: Residential Plumbing Retrofit**

Reporting Unit:

**Los Angeles Dept. of Water and Power**      **BMP Form Status: 100% Complete**      **Year: 2007**

**A. Implementation**

1. Is there an enforceable ordinance in effect in your service area requiring replacement of high-flow showerheads and other water use fixtures with their low-flow counterparts? yes

a. If YES, list local jurisdictions in your service area and code or ordinance in each:

City of Los Angeles "Water Closet, Urinal and Showerhead Regulations-Retrofit on Resale" Ordinance (No. 172075)

2. Has your agency satisfied the 75% saturation requirement for single-family housing units? yes

3. Estimated percent of single-family households with low-flow showerheads: 99%

4. Has your agency satisfied the 75% saturation requirement for multi-family housing units? yes

5. Estimated percent of multi-family households with low-flow showerheads: 99%

6. If YES to 2 OR 4 above, please describe how saturation was determined, including the dates and results of any survey research.

LA enacted an ordinance requiring all LADWP customers to install low flow showerheads & have installations certified or incur financial penalties for non-compliance. 99+% of LADWP customers have demonstrated compliance

**B. Low-Flow Device Distribution Information**

1. Has your agency developed a targeting/ marketing strategy for distributing low-flow devices? yes

a. If YES, when did your agency begin implementing this strategy? 07/01/1988

b. Describe your targeting/ marketing strategy.

Direct mail to all SF customers; element of all survey pgms; req'd per L.A. ordinance; provided upon request to any residential customer; distributed with program ULFTs.

<b>Low-Flow Devices Distributed/ Installed</b>	<b>SF Accounts</b>	<b>MF Units</b>
--	--------------------	-----------------

2. Number of low-flow showerheads distributed:	7694	24187
--	------	-------

3. Number of toilet-displacement devices distributed:	3	0
---	---	---

4. Number of toilet flappers distributed:	118	1658
---	-----	------

5. Number of faucet aerators distributed:	9395	38148
---	------	-------

6. Does your agency track the distribution and cost of low-flow devices? yes

a. If YES, in what format are low-flow devices tracked? Database

b. If yes, describe your tracking and distribution system :

Tracking: in-house inventory control; contractor invoices & support documentation. Distribution: direct install by CBOs; distribution by CBOs & through Conservation office.

**C. "At Least As Effective As"**

1. Is your AGENCY implementing an "at least as effective as" variant of this BMP? No

---

a. If YES, please explain in detail how your implementation of this BMP differs from Exhibit 1 and why you consider it to be "at least as effective as."

**D. Comments**

Direct install accounts for vast majority of devices and cost.  
Showerheads are 2.0 gpm

Reported as of 6/10/10

**BMP 03: System Water Audits, Leak Detection and Repair**

Reporting Unit: **Los Angeles Dept. of Water and Power**      BMP Form Status: **100% Complete**      Year: **2007**

**A. Implementation**

- 1. Does your agency own or operate a water distribution system? yes
- 2. Has your agency completed a pre-screening system audit for this reporting year? Yes
- 3. If YES, enter the values (AF/Year) used to calculate verifiable use as a percent of total production:
  - a. Determine metered sales (AF) 634178
  - b. Determine other system verifiable uses (AF) 0
  - c. Determine total supply into the system (AF) 666258
  - d. Using the numbers above, if (Metered Sales + Other Verifiable Uses) / Total Supply is < 0.9 then a full-scale system audit is required. 0.95
- 4. Does your agency keep necessary data on file to verify the values entered in question 3? yes
- 5. Did your agency complete a full-scale audit during this report year? no
- 6. Does your agency maintain in-house records of audit results or completed AWWA M36 audit worksheets for the completed audit which could be forwarded to CUWCC? yes
- 7. Does your agency operate a system leak detection program? no
  - a. If yes, describe the leak detection program:

**B. Survey Data**

- 1. Total number of miles of distribution system line. 7228
- 2. Number of miles of distribution system line surveyed. 0

**C. "At Least As Effective As"**

- 1. Is your AGENCY implementing an "at least as effective as" variant of this BMP? No
  - a. If YES, please explain in detail how your implementation of this BMP differs from Exhibit 1 and why you consider it to be "at least as effective as."

**D. Comments**

**Voluntary Questions (Not used to calculate compliance)**

**E. Volumes**

- |   | Estimated | Verified |
|---|-----------|----------|
| 1. Volume of raw water supplied to the system:      |           |          |
| 2. Volume treated water supplied into the system:   |           |          |
| 3. Volume of water exported from the system:        |           |          |
| 4. Volume of billed authorized metered consumption: |           |          |

5. Volume of billed authorized unmetered consumption:
6. Volume of unbilled authorized metered consumption:
7. Volume of unbilled authorized unmetered consumption:

## **F. Infrastructure and Hydraulics**

1. System input (source or master meter) volumes metered at the entry to the:
2. How frequently are they tested and calibrated?
3. Length of mains:
4. What % of distribution mains are rigid pipes (metal, ac, concrete)?
5. Number of service connections:
6. What % of service connections are rigid pipes (metal)?
7. Are residential properties fully metered?
8. Are non-residential properties fully metered?
9. Provide an estimate of customer meter under-registration:
10. Average length of customer service line from the main to the point of the meter:
11. Average system pressure:
12. Range of system pressures:

From to

13. What percentage of the system is fed from gravity feed?
14. What percentage of the system is fed by pumping and re-pumping?

## **G. Maintenance Questions**

1. Who is responsible for providing, testing, repairing and replacing customer meters?
2. Does your agency test, repair and replace your meters on a regular timed schedule?
  - a. If yes, does your agency test by meter size or customer category?:
    - Less than or equal to 1"
    - 1.5" to 2"
    - 3" and Larger
  - b. If yes to meter size, please provide the frequency of testing by meter size:
  - c. If yes to customer category, provide the frequency of testing by customer category:
    - SF residential
    - MF residential
    - Commercial
    - Industrial & Institutional
3. Who is responsible for repairs to the customer lateral or customer service line?
4. Who is responsible for service line repairs downstream of the customer meter?
5. Does your agency proactively search for leaks using leak

survey techniques or does your utility reactively repair leaks which are called in, or both?

6. What is the utility budget breakdown for:

Leak Detection	\$
Leak Repair	\$
Auditing and Water Loss Evaluation	\$
Meter Testing	\$

**H. Comments**

Reported as of 6/10/10

**BMP 04: Metering with Commodity Rates for all New Connections and Retrofit of Existing**

Reporting Unit: **Los Angeles Dept. of Water and Power**      BMP Form Status: **100% Complete**      Year: **2007**

**A. Implementation**

- 1. Does your agency have any unmetered service connections? No
  - a. If YES, has your agency completed a meter retrofit plan?
  - b. If YES, number of previously unmetered accounts fitted with meters during report year:
- 2. Are all new service connections being metered and billed by volume of use? Yes
- 3. Are all new service connections being billed volumetrically with meters? Yes
- 4. Has your agency completed and submitted electronically to the Council a written plan, policy or program to test, repair and replace meters? Yes
- 5. Please fill out the following matrix:

Account Type	Number of Metered Accounts	Number of Metered Accounts Read	Number of Metered Accounts Billed by Volume	Billing Frequency Per Year	Number of Volume Estimates
a. Single Family	483433	483433	483433	6	0
b. Multi-Family	121693	121693	121693	6	0
c. Commercial	60327	60327	60327	12	0
d. Industrial	6552	6552	6552	12	0
e. Institutional	6707	6707	6707	12	0
f. Landscape Irrigation	766	766	766	12	0

**B. Feasibility Study**

- 1. Has your agency conducted a feasibility study to assess the merits of a program to provide incentives to switch mixed-use accounts to dedicated landscape meters? no
  - a. If YES, when was the feasibility study conducted? (mm/dd/yy)

b. Describe the feasibility study:

- 2. Number of CII accounts with mixed-use meters: 60437
- 3. Number of CII accounts with mixed-use meters retrofitted with dedicated irrigation meters during reporting period. 0

**C. "At Least As Effective As"**

- 1. Is your agency implementing an "at least as effective as" variant of this BMP? No
- a. If YES, please explain in detail how your implementation of this BMP differs from Exhibit 1 and why you consider it to be "at least as effective as."

**D. Comments**

Fire services are metered; hydrants are not.

**BMP 05: Large Landscape Conservation Programs and Incentives**

Reporting Unit: **Los Angeles Dept. of Water and Power**      BMP Form Status: **100% Complete**      Year: **2007**

**A. Water Use Budgets**

- 1. Number of Dedicated Irrigation Meter Accounts: 745
- 2. Number of Dedicated Irrigation Meter Accounts with Water Budgets: 258
- 3. Budgeted Use for Irrigation Meter Accounts with Water Budgets (AF): 0
- 4. Actual Use for Irrigation Meter Accounts with Water Budgets (AF): 0
- 5. Does your agency provide water use notices to accounts with budgets each billing cycle? yes

**B. Landscape Surveys**

- 1. Has your agency developed a marketing / targeting strategy for landscape surveys? yes
  - a. If YES, when did your agency begin implementing this strategy? 6/10/1996
  - b. Description of marketing / targeting strategy:

Work with LA Dept Rec & Parks, school district to audit and provide audit training. All accts applying for landscape incentives also audited. Review consumption history for excess use.

- 2. Number of Surveys Offered. 15
- 3. Number of Surveys Completed. 11
- 4. Indicate which of the following Landscape Elements are part of your survey:
  - a. Irrigation System Check yes
  - b. Distribution Uniformity Analysis yes
  - c. Review / Develop Irrigation Schedules yes
  - d. Measure Landscape Area yes
  - e. Measure Total Irrigable Area yes
  - f. Provide Customer Report / Information yes



- 5. Do you track survey offers and results? yes
- 6. Does your agency provide follow-up surveys for previously completed surveys? yes

a. If YES, describe below:

Accounts with poor distribution uniformity re-audited after system improvements completed

**C. Other BMP 5 Actions**

- 1. An agency can provide mixed-use accounts with ETo-based landscape budgets in lieu of a large landscape survey program. no  
Does your agency provide mixed-use accounts with landscape budgets?
- 2. Number of CII mixed-use accounts with landscape budgets. 0
- 3. Do you offer landscape irrigation training? yes
- 4. Does your agency offer financial incentives to improve landscape water use efficiency? yes

Type of Financial Incentive:	Budget (Dollars/Year)	Number Awarded to Customers	Total Amount Awarded
a. Rebates	100000	0	0
b. Loans	0	0	0
c. Grants	80000	0	0

- 5. Do you provide landscape water use efficiency information to new customers and customers changing services? No

a. If YES, describe below:

- 6. Do you have irrigated landscaping at your facilities? yes
  - a. If yes, is it water-efficient? yes
  - b. If yes, does it have dedicated irrigation metering? yes
- 7. Do you provide customer notices at the start of the irrigation season? no
- 8. Do you provide customer notices at the end of the irrigation season? no

**D. "At Least As Effective As"**

- 1. Is your AGENCY implementing an "at least as effective as" variant of this BMP? Yes

a. If YES, please explain in detail how your implementation of this BMP differs from Exhibit 1 and why you consider it to be "at least as effective as."

The Los Angeles Department of Water and Power (LADWP) is taking a multi-pronged approach and implementing several programs to target our large landscapes (e.g. parks and schools) and commercial, industrial, and institutional (CII) customers having irrigated landscapes. LADWP implements the ambitious Technical Assistance Program (TAP), which is a custom financial incentive program offering CII and Multi-Family Residential customers in Los Angeles up to \$250,000 for the installation of pre-approved equipment and products (including the design and installation of efficient irrigation systems) that demonstrate persistent water savings. LADWP staff is currently working with a major customer on significant modifications for a new proprietary process that will conserve a considerable amount of water annually. LADWP has entered into a Memorandum of Understanding (MOU) with the Los Angeles

Department of Recreation and Parks (RAP) for the purpose of funding water use efficiency improvements for large landscapes in City parks. These water conservation improvements that LADWP and RAP are working in partnership to advance include installation of weather-based irrigation controllers, high efficiency sprinkler heads, and repair or replacement of irrigation distribution systems. The MOU strengthens LADWP's commitment to conservation as a means of providing a sustainable source of water to the City of Los Angeles as adopted by the Board in the 2005 Urban Water Management Plan. In August of 2008, LADWP amended its Emergency Water Conservation Plan (a City Ordinance) to address the increasing water shortage. The Plan's requirements are applicable to all LADWP customers, and are focused primarily on landscape irrigation. The Plan permits customers to use water only during specified hours of the day and specified days of the week, depending on the declared severity of water shortage. Water allotment varies by each phase (I-VI), such that phase I has the least amount of restrictions and phase VI having the most stringent restrictions. LADWP is currently developing a proposal for "Shortage Year" Water Rates (Tier 1 and Tier 2) for both commercial and residential customers that will become effective in mid-2009. Customers will be required to conserve 15% below their Tier 1 allotment to avoid a bill increase; however, those who exceed their allotment must pay Tier 2 rates resulting in higher water bills. Shortage Year Water Rates are designed to ensure that costs are recovered without penalizing customers who conserve during the years when projected demand for water exceeds the available supply. As has been demonstrated by LADWP's 100% volumetric rate structure, price signal is a most effective conservation tool. In addition to the Ordinance modifications described above, LADWP has developed and is planning to launch a Turf Buy Back Program in 2009. This new program will pay single family residential and commercial customers \$1.00 per square foot of turf removed and replaced with drought tolerant plants, mulch or permeable hardscape. Any subsequent irrigation requirements will be met with low volume drip or microspray emitters. LADWP is also in the process of expanding our recycled water program and are working with water intensive CII customers such as golf courses, parks, and refineries to promote and use recycled water. LADWP is currently converting all of our golf courses and parks to dedicated irrigation meters for the usage of recycled water. Our recycled water goal is to deliver at least 50,000 acre-feet per year by 2019. This will be done by expanding the "purple pipe" distribution system to new customers who can use recycled water for non-potable uses such as irrigation and industrial processes.

#### E. Comments

Reported as of 6/10/10

### **BMP 06: High-Efficiency Washing Machine Rebate Programs**

Reporting Unit: <b>Los Angeles Dept. of Water and Power</b>	BMP Form Status: <b>100% Complete</b>	Year: <b>2007</b>
--	--	----------------------

#### A. Implementation

1. Do any energy service providers or waste water utilities in your service area offer rebates for high-efficiency washers?
  - a. If YES, describe the offerings and incentives as well as who the

energy/waste water utility provider is.

2. Does your agency offer rebates for high-efficiency washers? yes  
 3. What is the level of the rebate?  
 4. Number of rebates awarded.

### B. Rebate Program Expenditures

This Year Next Year

1. Budgeted Expenditures  
 2. Actual Expenditures

### C. "At Least As Effective As"

1. Is your AGENCY implementing an "at least as effective as" variant of this BMP? no  
 a. If YES, please explain in detail how your implementation of this BMP differs from Exhibit 1 and why you consider it to be "at least as effective as."

### D. Comments

Reported as of 6/10/10

## BMP 07: Public Information Programs

Reporting Unit:

**Los Angeles Dept. of Water and Power**

BMP Form Status:  
**100% Complete**

Year:  
**2007**

### A. Implementation

1. How is your public information program implemented?  
 Wholesaler and retailer both materially participate in program  
 Which wholesaler(s)?  
 Metropolitan Water District of Southern California
2. Describe the program and how it's organized:  
 LADWP's Public Affairs Division works closely with the Water Conservation office. Information is made available on LADWP Web site, conservation publications distributed at public venues and by request (in English and Spanish); customer newsletter; Speakers Bureau and school presentations; fleet vehicle signage; posters and brochures in LADWP Customer Service Centers and City Council field offices; permanent water display located at Olvera Street, a popular Los Angeles landmark and tourist venue; a special flier regarding conservation was produced and inserted for distribution in the Los Angeles Times and Daily News in English and in Impacto in Spanish. Print advertisements were placed twice monthly beginning in November of 2005 and terminating December 2006 in various languages in the community press and major daily newspapers serving Los Angeles to Promote awareness of and participation in LADWP's residential water conservation programs. The LADWP Public Affairs Division prepares an outreach program annually based on the specific program needs of the Water Conservation office. Public Affairs implements the elements of the program which include development and production of collateral materials and exhibits; development and placement of all advertisements and public service announcements; development and posting of Web site announcements. MWDSO independently promotes conservation through various media channels and directly promotes programs via the bewaterwise.com website as well as by its program

implementation contractor.

3. Indicate which and how many of the following activities are included in your public information program:

Public Information Program Activity in Retail Service Area	Yes/No	Number of Events
a. Paid Advertising	yes	81
b. Public Service Announcement	no	
c. Bill Inserts / Newsletters / Brochures	yes	21
d. Bill showing water usage in comparison to previous year's usage	yes	
e. Demonstration Gardens	no	
f. Special Events, Media Events	yes	3
g. Speaker's Bureau	yes	5
h. Program to coordinate with other government agencies, industry and public interest groups and media	yes	

**B. Conservation Information Program Expenditures**

1. Annual Expenditures (Excluding Staffing)

**C. "At Least As Effective As"**

1. Is your AGENCY implementing an "at least as effective as" variant of this BMP? No

a. If YES, please explain in detail how your implementation of this BMP differs from Exhibit 1 and why you consider it to be "at least as effective as."

**D. Comments**

Reported as of 6/10/10

**BMP 08: School Education Programs**

Reporting Unit:

Los Angeles Dept. of Water and Power

BMP Form Status:  
100% Complete

Year:  
2007

**A. Implementation**

1. How is your public information program implemented?

Retailer runs program without wholesaler sponsorship

2. Please provide information on your region-wide school programs (by grade level):

Grade	Are grade-appropriate materials distributed?	No. of class presentations	No. of students reached	No. of teachers' workshops
Grades K-3rd	yes	2	490	13
Grades 4th-6th	yes	2	4325	13
Grades 7th-8th	yes	0	37800	13
High School	yes	0	56800	13

- 4. Did your Agency's materials meet state education framework requirements? yes
- 5. When did your Agency begin implementing this program? 09/15/1975

**B. School Education Program Expenditures**

- 1. Annual Expenditures (Excluding Staffing)

**C. "At Least As Effective As"**

- 1. Is your AGENCY implementing an "at least as effective as" variant of this BMP? No
  - a. If YES, please explain in detail how your implementation of this BMP differs from Exhibit 1 and why you consider it to be "at least as effective as."

**D. Comments**

Teachers' guide and supporting materials funded and/or provided by LADWP. Dedicated LADWP staff coordinate with school district throughout the school year.

Reported as of 6/10/10

**BMP 09: Conservation Programs for CII Accounts**

Reporting Unit: **Los Angeles Dept. of Water and Power**      BMP Form Status: **100% Complete**      Year: **2007**

**A. Implementation**

- 1. Has your agency identified and ranked COMMERCIAL customers according to use? yes
- 2. Has your agency identified and ranked INDUSTRIAL customers according to use? yes
- 3. Has your agency identified and ranked INSTITUTIONAL customers according to use? yes

**Option A: CII Water Use Survey and Customer Incentives Program**

- 4. Is your agency operating a CII water use survey and customer incentives program for the purpose of complying with BMP 9 under this option? If so, please describe activity during reporting period: yes

CII Surveys	Commercial Accounts	Industrial Accounts	Institutional Accounts
a. Number of New Surveys Offered	25	10	4
b. Number of New Surveys Completed	25	10	4
c. Number of Site Follow-ups of Previous Surveys (within 1 yr)	10	6	1
d. Number of Phone Follow-ups of Previous Surveys (within 1 yr)	10	3	1
<b>CII Survey Components</b>	<b>Commercial</b>	<b>Industrial</b>	<b>Institutional</b>

	Accounts	Accounts	Accounts
e. Site Visit	yes	yes	yes
f. Evaluation of all water-using apparatus and processes	yes	yes	yes
g. Customer report identifying recommended efficiency measures, paybacks and agency incentives	yes	yes	yes
Agency CII Customer Incentives	Budget (\$/Year)	# Awarded to Customers	Total \$ Amount Awarded
h. Rebates	150000	6980	737808
i. Loans	0	0	0
j. Grants	350000	0	0
k. Others	0	0	0

**Option B: CII Conservation Program Targets**

5. Does your agency track CII program interventions and water savings for the purpose of complying with BMP 9 under this option? yes

6. Does your agency document and maintain records on how savings were realized and the method of calculation for estimated savings? yes

**7. System Calculated annual savings (AF/yr):**

CII Programs	# Device Installations
a. Ultra Low Flush Toilets	4469
b. Dual Flush Toilets	1
c. High Efficiency Toilets	1404
d. High Efficiency Urinals	0
e. Non-Water Urinals	0
f. Commercial Clothes Washers (coin-op only; not industrial)	1037
g. Cooling Tower Controllers	23
h. Food Steamers	0
i. Ice Machines	0
j. Pre-Rinse Spray Valves	0
k. Steam Sterilizer Retrofits	0
l. X-ray Film Processors	0

**8. Estimated annual savings (AF/yr) from agency programs not including the devices listed in Option B. 7., above:**

CII Programs	Annual Savings (AF/yr)
a. Site-verified actions taken by agency:	0
b. Non-site-verified actions taken by agency:	0

**B. Conservation Program Expenditures for CII Accounts**

**This Year      Next Year**

1. Budgeted Expenditures	2750000	2750000
2. Actual Expenditures	737808	

**C. "At Least As Effective As"**

1. Is your agency implementing an "at least as effective as" variant of this BMP? No

a. If YES, please explain in detail how your implementation of this BMP differs from Exhibit 1 and why you consider it to be "at least as effective as."

**D. Comments**

**BMP 11: Conservation Pricing**

Reporting Unit: **Los Angeles Dept. of Water and Power**      BMP Form Status: **100% Complete**      Year: **2007**

**A. Implementation**

**Water Service Rate Structure Data by Customer Class**

**1. Single Family Residential**

a. Rate Structure	Increasing Block Seasonal
b. Total Revenue from Commodity Charges (Volumetric Rates)	\$ 274,814,458
c. Total Revenue from Customer Meter/Service (Fixed) Charges	\$ .

**2. Multi-Family Residential**

a. Rate Structure	Increasing Block Seasonal
b. Total Revenue from Commodity Charges (Volumetric Rates)	\$ 188,638,894
c. Total Revenue from Customer Meter/Service (Fixed) Charges	\$ 0

**3. Commercial**

a. Rate Structure	Increasing Block Seasonal
b. Total Revenue from Commodity Charges (Volumetric Rates)	\$ 119,179,953
c. Total Revenue from Customer Meter/Service (Fixed) Charges	\$ 0

**4. Industrial**

a. Rate Structure	Increasing Block Seasonal
b. Total Revenue from Commodity Charges (Volumetric Rates)	\$ 23,200,289
c. Total Revenue from Customer Meter/Service (Fixed) Charges	\$ 0

**5. Institutional / Government**

a. Rate Structure	Increasing Block Seasonal
b. Total Revenue from Commodity Charges (Volumetric Rates)	\$ 32,620,283
c. Total Revenue from Customer Meter/Service (Fixed) Charges	\$ 0

<b>6. Dedicated Irrigation (potable)</b>	
a. Rate Structure	Increasing Block Seasonal
b. Total Revenue from Commodity Charges (Volumetric Rates)	\$ 7,587,195
c. Total Revenue from Customer Meter/Service (Fixed) Charges	\$ 0
<b>7. Recycled-Reclaimed</b>	
a. Rate Structure	Uniform
b. Total Revenue from Commodity Charges (Volumetric Rates)	\$ 2,665,729
c. Total Revenue from Customer Meter/Service (Fixed) Charges	\$ 0
<b>8. Raw</b>	
a. Rate Structure	Service Not Provided
b. Total Revenue from Commodity Charges (Volumetric Rates)	\$ 0
c. Total Revenue from Customer Meter/Service (Fixed) Charges	\$ 0
<b>9. Other</b>	
a. Rate Structure	Service Not Provided
b. Total Revenue from Commodity Charges (Volumetric Rates)	\$ 0
c. Total Revenue from Customer Meter/Service (Fixed) Charges	\$ 0

**B. Implementation Options**

**Select Either Option 1 or Option 2:**

**1. Option 1: Use Annual Revenue As Reported**  
 $V/(V+M) \geq 70\%$

V = Total annual revenue from volumetric rates  
 M = Total annual revenue from customer meter/service (fixed) charges

Selected

**2. Option 2: Use Canadian Water & Wastewater Association Rate Design Model**

$V/(V+M) \geq V'/(V'+M')$   
 V = Total annual revenue from volumetric rates  
 M = Total annual revenue from customer meter/service (fixed) charges

V' = The uniform volume rate based on the signatory's long-run incremental cost of service  
 M' = The associated meter charge

a. If you selected Option 2, has your agency submitted to the Council a completed Canadian Water & Wastewater Association rate design model?

b. Value for V' (uniform volume rate based on agency's long-run incremental cost of service) as determined by the Canadian Water & Wastewater Association rate design model:

c. Value for M' (meter charge associated with V' uniform volume rate) as determined by the Canadian Water & Wastewater Association rate design model:

**C. Retail Wastewater (Sewer) Rate Structure Data by Customer Class**



1. Does your agency provide sewer service? (If YES, answer questions 2 - 7 below, else continue to section D.) No

**2. Single Family Residential**

- a. Sewer Rate Structure
- b. Total Annual Revenue \$ 0
- c. Total Revenue from Commodity Charges (Volumetric Rates) \$ 0

**3. Multi-Family Residential**

- a. Sewer Rate Structure
- b. Total Annual Revenue \$ 0
- c. Total Revenue from Commodity Charges (Volumetric Rates) \$ 0

**4. Commercial**

- a. Sewer Rate Structure
- b. Total Annual Revenue \$ 0
- c. Total Revenue from Commodity Charges (Volumetric Rates) \$ 0

**5. Industrial**

- a. Sewer Rate Structure
- b. Total Annual Revenue \$ 0
- c. Total Revenue from Commodity Charges (Volumetric Rates) \$ 0

**6. Institutional / Government**

- a. Sewer Rate Structure
- b. Total Annual Revenue \$ 0
- c. Total Revenue from Commodity Charges (Volumetric Rates) \$ 0

**7. Recycled-reclaimed water**

- a. Sewer Rate Structure
- b. Total Annual Revenue \$ 0
- c. Total Revenue from Commodity Charges (Volumetric Rates) \$ 0

**D. "At Least As Effective As"**

1. Is your agency implementing an "at least as effective as" variant of this BMP? No

a. If YES, please explain in detail how your implementation of this BMP differs from Exhibit 1 and why you consider it to be "at least as effective as."

**E. Comments**

Link to LADWP Water Rate Ordinance:  
<http://www.ladwp.com/ladwp/cms/ladwp001149.pdf>

**BMP 12: Conservation Coordinator**

Reporting Unit:

**Los Angeles Dept. of Water and Power**BMP Form Status:  
**100% Complete**Year:  
**2007****A. Implementation**

1. Does your Agency have a conservation coordinator? yes
2. Is a coordinator position supplied by another agency with which you cooperate in a regional conservation program ? no
  - a. Partner agency's name:
3. If your agency supplies the conservation coordinator:
  - a. What percent is this conservation coordinator's position? 100%
  - b. Coordinator's Name Thomas Gackstetter
  - c. Coordinator's Title Water Conservation Manager
  - d. Coordinator's Experience and Number of Years 20
  - e. Date Coordinator's position was created (mm/dd/yyyy) 12/11/1991
4. Number of conservation staff (FTEs), including Conservation Coordinator. 5

**B. Conservation Staff Program Expenditures**

1. Staffing Expenditures (In-house Only) 597610
2. BMP Program Implementation Expenditures 5989000

**C. "At Least As Effective As"**

1. Is your AGENCY implementing an "at least as effective as" variant of this BMP? no
  - a. If YES, please explain in detail how your implementation of this BMP differs from Exhibit 1 and why you consider it to be "at least as effective as."

**D. Comments****BMP 13: Water Waste Prohibition**

Reporting Unit:

**Los Angeles Dept. of Water and Power**BMP Form Status:  
**100% Complete**Year:  
**2007****A. Requirements for Documenting BMP Implementation**

1. Is a water waste prohibition ordinance in effect in your service area? yes
  - a. If YES, describe the ordinance:  
  
Prohibits use of water on hardscape, gutter flooding, unattended leaks, mid-day watering, serving water in restaurants w/o request, non recirc fountains
2. Is a copy of the most current ordinance(s) on file with CUWCC? yes
  - a. List local jurisdictions in your service area in the first text box and water waste ordinance citations in each jurisdiction in the second text

box:

City of Los Angeles

Ord No. 166080

**B. Implementation**

1. Indicate which of the water uses listed below are prohibited by your agency or service area.

- a. Gutter flooding yes
- b. Single-pass cooling systems for new connections Yes
- c. Non-recirculating systems in all new conveyor or car wash systems Yes
- d. Non-recirculating systems in all new commercial laundry systems Yes
- e. Non-recirculating systems in all new decorative fountains yes
- f. Other, please name yes  
See above

2. Describe measures that prohibit water uses listed above:

Specific ordinance language, monetary penalties, service restrictions/shutoff. Cost of water/wastewater and common practice limits number of single pass systems

**Water Softeners:**

3. Indicate which of the following measures your agency has supported in developing state law:

- a. Allow the sale of more efficient, demand-initiated regenerating DIR models. no
- b. Develop minimum appliance efficiency standards that:
  - i.) Increase the regeneration efficiency standard to at least 3,350 grains of hardness removed per pound of common salt used. no
  - ii.) Implement an identified maximum number of gallons discharged per gallon of soft water produced. no
- c. Allow local agencies, including municipalities and special districts, to set more stringent standards and/or to ban on-site regeneration of water softeners if it is demonstrated and found by the agency governing board that there is an adverse effect on the reclaimed water or groundwater supply. no

4. Does your agency include water softener checks in home water audit programs? no

5. Does your agency include information about DIR and exchange-type water softeners in educational efforts to encourage replacement of less efficient timer models? no

**C. "At Least As Effective As"**

1. Is your AGENCY implementing an "at least as effective as" variant of this BMP? no

- a. If YES, please explain in detail how your implementation of this BMP differs from Exhibit 1 and why you consider it to be "at least as effective as."

**D. Comments**

**BMP 14: Residential ULFT Replacement Programs**

Reporting Unit: **Los Angeles Dept. of Water and Power**      BMP Form Status: **100% Complete**      Year: **2007**

**A. Implementation**

**Number of 1.6 gpf Toilets Replaced by Agency Program During Report Year**

	<b>Single-Family Accounts</b>	<b>Multi-Family Units</b>
1. Does your Agency have program(s) for replacing high-water-using toilets with ultra-low flush toilets?	yes	yes
<b>Replacement Method</b>	<b>SF Accounts</b>	<b>MF Units</b>
2. Rebate	2043	386
3. Direct Install	5448	9912
4. CBO Distribution	126	92
5. Other	0	0
<b>Total</b>	<b>7617</b>	<b>10390</b>

**Number of 1.2 gpf High-Efficiency Toilets (HETs) Replaced by Agency Program During Report Year**

	<b>Single-Family Accounts</b>	<b>Multi-Family Units</b>
6. Does your Agency have program(s) for replacing high-water-using toilets with ultra-low flush toilets?	no	no
<b>Replacement Method</b>	<b>SF Accounts</b>	<b>MF Units</b>
7. Rebate		
8. Direct Install		
9. CBO Distribution		
10. Other		
<b>Total</b>		

**Number of Dual-Flush Toilets Replaced by Agency Program During Report Year**

	<b>Single-Family Accounts</b>	<b>Multi-Family Units</b>
11. Does your Agency have program(s) for replacing high-water-using toilets with ultra-low flush toilets?	no	no
<b>Replacement Method</b>	<b>SF Accounts</b>	<b>MF Units</b>
12. Rebate	0	0
13. Direct Install	0	0
14. CBO Distribution	0	0
15. Other	0	0
<b>Total</b>	<b>0</b>	<b>0</b>

16. Describe your agency's ULFT, HET, and/or Dual-Flush Toilet programs for

single-family residences.

Rebate of \$100 per toilet replaced or free toilet in exchange for old toilet (installed free on request). Rebate paid on ULFT, HET and Dual Flush.

17. Describe your agency's ULFT, HET, and/or Dual-Flush Toilet programs for multi-family residences.

Rebate of \$75 per toilet replaced or free toilet in exchange for old toilet (installed free on request). Rebate paid on ULFT, HET and Dual Flush.

18. Is a toilet retrofit on resale ordinance in effect for your service area? yes

19. List local jurisdictions in your service area in the left box and ordinance citations in each jurisdiction in the right box:

City of Los Angeles

Ord. No. 172075

**B. Residential ULFT Program Expenditures**

1. Estimated cost per ULFT/HET replacement: 242.86

**C. "At Least As Effective As"**

1. Is your AGENCY implementing an "at least as effective as" variant of this BMP? no

a. If YES, please explain in detail how your implementation of this BMP differs from Exhibit 1 and why you consider it to be "at least as effective as."

**D. Comments**

Cost per unit includes all programmatic costs.

**Water Supply & Reuse**

Reporting Unit:

**Los Angeles Dept. of Water and Power**

Year:

**2008****Water Supply Source Information**

<b>Supply Source Name</b>	<b>Quantity (AF) Supplied</b>	<b>Supply Type</b>
LA Aqueduct	152642	Imported
MWDSC	421732	Imported
Groundwater	71023	Groundwater
Recycled	4273	Recycled
Transfer	1241	Imported
Storage	198	Imported

**Total AF: 651109**

Reported as of 6/10/10

**Accounts & Water Use**

Reporting Unit Name: **Los Angeles Dept. of Water and Power** Submitted to CUWCC **02/08/2009** Year: **2008**

What is the reporting year? Fiscal Month Ending June

**A. Service Area Population Information:**

1. Total service area population 4071873

**B. Number of Accounts and Water Deliveries (AF)**

Type	Metered		Unmetered	
	No. of Accounts	Water Deliveries (AF)	No. of Accounts	Water Deliveries (AF)
1. Single-Family	482675	249530	0	0
2. Multi-Family	124403	183064	0	0
3. Commercial	72403	109091	0	0
4. Industrial	6830	24257	0	0
5. Institutional	7583	44803	0	0
6. Dedicated Irrigation	766	264	0	0
7. Recycled Water	45	4130	0	0
8. Other	0	0	0	0
9. Unaccounted	NA	37223	NA	0
<b>Total</b>	<b>694705</b>	<b>652362</b>	<b>0</b>	<b>0</b>

Metered Unmetered

Reported as of 6/10/10

**BMP 01: Water Survey Programs for Single-Family and Multi-Family Residential Customers**

Reporting Unit: **Los Angeles Dept. of Water and Power** BMP Form Status: **100% Complete** Year: **2008**

**A. Implementation**

- 1. Based on your signed MOU date, 09/12/1991, your Agency STRATEGY DUE DATE is: 09/11/1993
- 2. Has your agency developed and implemented a targeting/marketing strategy for SINGLE-FAMILY residential water use surveys? yes
  - a. If YES, when was it implemented? 06/01/1990
- 3. Has your agency developed and implemented a targeting/marketing strategy for MULTI-FAMILY residential water use surveys? yes
  - a. If YES, when was it implemented? 06/01/1990

**B. Water Survey Data**

Single

<b>Survey Counts:</b>	<b>Family Accounts</b>	<b>Multi-Family Units</b>
1. Number of surveys offered:	0	0
2. Number of surveys completed:	0	0

**Indoor Survey:**

3. Check for leaks, including toilets, faucets and meter checks	yes	yes
4. Check showerhead flow rates, aerator flow rates, and offer to replace or recommend replacement, if necessary	yes	yes
5. Check toilet flow rates and offer to install or recommend installation of displacement device or direct customer to ULFT replacement program, as necessary; replace leaking toilet flapper, as necessary	yes	yes

**Outdoor Survey:**

6. Check irrigation system and timers	no	no
7. Review or develop customer irrigation schedule	no	no
8. Measure landscaped area (Recommended but not required for surveys)	no	no
9. Measure total irrigable area (Recommended but not required for surveys)	no	no
10. Which measurement method is typically used (Recommended but not required for surveys)		None
11. Were customers provided with information packets that included evaluation results and water savings recommendations?	no	no
12. Have the number of surveys offered and completed, survey results, and survey costs been tracked?	yes	no
a. If yes, in what form are surveys tracked?		manual activity
b. Describe how your agency tracks this information.		

In-house filing system

**C. "At Least As Effective As"**

1. Is your AGENCY implementing an "at least as effective as" variant of this BMP?	No
a. If YES, please explain in detail how your implementation of this BMP differs from Exhibit 1 and why you consider it to be "at least as effective as."	

**D. Comments**

Period: FY 07-08 ULFT Rebate and D.I. programs end on 12/31/06.  
Marketing stops.

Reported as of 6/10/10

**BMP 02: Residential Plumbing Retrofit**

Reporting Unit:

**Los Angeles Dept. of Water and**      **BMP Form Status:**      **Year:**



**Power** **100% Complete** **2008**

**A. Implementation**

1. Is there an enforceable ordinance in effect in your service area requiring replacement of high-flow showerheads and other water use fixtures with their low-flow counterparts? **yes**

a. If YES, list local jurisdictions in your service area and code or ordinance in each:

City of Los Angeles "Water Closet, Urinal and Showerhead Regulations-Retrofit on Resale" Ordinance (No. 172075)

2. Has your agency satisfied the 75% saturation requirement for single-family housing units? **yes**

3. Estimated percent of single-family households with low-flow showerheads: **99%**

4. Has your agency satisfied the 75% saturation requirement for multi-family housing units? **yes**

5. Estimated percent of multi-family households with low-flow showerheads: **99%**

6. If YES to 2 OR 4 above, please describe how saturation was determined, including the dates and results of any survey research.

LA enacted an ordinance requiring all LADWP customers to install low flow showerheads & have installations certified or incur financial penalties for non-compliance. 99+% of LADWP customers have demonstrated compliance

**B. Low-Flow Device Distribution Information**

1. Has your agency developed a targeting/ marketing strategy for distributing low-flow devices? **yes**

a. If YES, when did your agency begin implementing this strategy? **07/01/1988**

b. Describe your targeting/ marketing strategy.

Direct mail to all SF customers; element of all survey pgms; req'd per L.A. ordinance; provided upon request to any residential customer; distributed with program ULFTs.

Low-Flow Devices Distributed/ Installed	SF Accounts	MF Units
---	-------------	----------

2. Number of low-flow showerheads distributed:	3812	12896
--	------	-------

3. Number of toilet-displacement devices distributed:	2	0
---	---	---

4. Number of toilet flappers distributed:	39	11
---	----	----

5. Number of faucet aerators distributed:	57	2300
---	----	------

6. Does your agency track the distribution and cost of low-flow devices? **yes**

a. If YES, in what format are low-flow devices tracked? **Database**

b. If yes, describe your tracking and distribution system :

Tracking: in-house inventory control; Distribution through Water Conservation office to customers who call in and through LADWP account executives.

**C. "At Least As Effective As"**

1. Is your AGENCY implementing an "at least as effective as" variant of this BMP? **No**

a. If YES, please explain in detail how your implementation of this BMP

differs from Exhibit 1 and why you consider it to be "at least as effective as."

**D. Comments**

Reported as of 6/10/10

**BMP 03: System Water Audits, Leak Detection and Repair**

Reporting Unit: **Los Angeles Dept. of Water and Power**      BMP Form Status: **100% Complete**      Year: **2008**

**A. Implementation**

- 1. Does your agency own or operate a water distribution system? yes
- 2. Has your agency completed a pre-screening system audit for this reporting year? Yes
- 3. If YES, enter the values (AF/Year) used to calculate verifiable use as a percent of total production:
  - a. Determine metered sales (AF) 611008
  - b. Determine other system verifiable uses (AF) 0
  - c. Determine total supply into the system (AF) 648231
  - d. Using the numbers above, if (Metered Sales + Other Verifiable Uses) / Total Supply is < 0.9 then a full-scale system audit is required. 0.94
- 4. Does your agency keep necessary data on file to verify the values entered in question 3? yes
- 5. Did your agency complete a full-scale audit during this report year? no
- 6. Does your agency maintain in-house records of audit results or completed AWWA M36 audit worksheets for the completed audit which could be forwarded to CUWCC? yes
- 7. Does your agency operate a system leak detection program? no
  - a. If yes, describe the leak detection program:

**B. Survey Data**

- 1. Total number of miles of distribution system line. 7228
- 2. Number of miles of distribution system line surveyed. 0

**C. "At Least As Effective As"**

- 1. Is your AGENCY implementing an "at least as effective as" variant of this BMP? No
  - a. If YES, please explain in detail how your implementation of this BMP differs from Exhibit 1 and why you consider it to be "at least as effective as."

**D. Comments**

**Voluntary Questions (Not used to calculate compliance)**

**E. Volumes**

- |   | Estimated | Verified |
|---|-----------|----------|
| 1. Volume of raw water supplied to the system:      |           |          |
| 2. Volume treated water supplied into the system:   |           |          |
| 3. Volume of water exported from the system:        |           |          |
| 4. Volume of billed authorized metered consumption: |           |          |

5. Volume of billed authorized unmetered consumption:
6. Volume of unbilled authorized metered consumption:
7. Volume of unbilled authorized unmetered consumption:

#### **F. Infrastructure and Hydraulics**

1. System input (source or master meter) volumes metered at the entry to the:
2. How frequently are they tested and calibrated?
3. Length of mains:
4. What % of distribution mains are rigid pipes (metal, ac, concrete)?
5. Number of service connections:
6. What % of service connections are rigid pipes (metal)?
7. Are residential properties fully metered?
8. Are non-residential properties fully metered?
9. Provide an estimate of customer meter under-registration:
10. Average length of customer service line from the main to the point of the meter:
11. Average system pressure:
12. Range of system pressures:

From to

13. What percentage of the system is fed from gravity feed?
14. What percentage of the system is fed by pumping and re-pumping?

#### **G. Maintenance Questions**

1. Who is responsible for providing, testing, repairing and replacing customer meters?
2. Does your agency test, repair and replace your meters on a regular timed schedule?
  - a. If yes, does your agency test by meter size or customer category?:
    - Less than or equal to 1"
    - 1.5" to 2"
    - 3" and Larger
  - b. If yes to meter size, please provide the frequency of testing by meter size:
  - c. If yes to customer category, provide the frequency of testing by customer category:
    - SF residential
    - MF residential
    - Commercial
    - Industrial & Institutional
3. Who is responsible for repairs to the customer lateral or customer service line?
4. Who is responsible for service line repairs downstream of the customer meter?
5. Does your agency proactively search for leaks using leak

survey techniques or does your utility reactively repair leaks which are called in, or both?

6. What is the utility budget breakdown for:

Leak Detection	\$
Leak Repair	\$
Auditing and Water Loss Evaluation	\$
Meter Testing	\$

**H. Comments**

Reported as of 6/10/10

**BMP 04: Metering with Commodity Rates for all New Connections and Retrofit of Existing**

Reporting Unit: **Los Angeles Dept. of Water and Power**      BMP Form Status: **100% Complete**      Year: **2008**

**A. Implementation**

- 1. Does your agency have any unmetered service connections? No
  - a. If YES, has your agency completed a meter retrofit plan?
  - b. If YES, number of previously unmetered accounts fitted with meters during report year:
- 2. Are all new service connections being metered and billed by volume of use? Yes
- 3. Are all new service connections being billed volumetrically with meters? Yes
- 4. Has your agency completed and submitted electronically to the Council a written plan, policy or program to test, repair and replace meters? Yes
- 5. Please fill out the following matrix:

Account Type	Number of Metered Accounts	Number of Metered Accounts Read	Number of Metered Accounts Billed by Volume	Billing Frequency Per Year	Number of Volume Estimates
a. Single Family	483433	483433	483433	6	0
b. Multi-Family	121693	121693	121693	6	0
c. Commercial	60327	60327	60327	12	0
d. Industrial	6552	6552	6552	12	0
e. Institutional	6707	6707	6707	12	0
f. Landscape Irrigation	766	766	766	12	0

**B. Feasibility Study**

- 1. Has your agency conducted a feasibility study to assess the merits of a program to provide incentives to switch mixed-use accounts to dedicated landscape meters? no
  - a. If YES, when was the feasibility study conducted? (mm/dd/yy)

## b. Describe the feasibility study:

- |   |       |
|---|-------|
| 2. Number of CII accounts with mixed-use meters:  | 60327 |
| 3. Number of CII accounts with mixed-use meters retrofitted with dedicated irrigation meters during reporting period. | 0     |

**C. "At Least As Effective As"**

- |   |    |
|---|----|
| 1. Is your agency implementing an "at least as effective as" variant of this BMP? | No |
|---|----|

a. If YES, please explain in detail how your implementation of this BMP differs from Exhibit 1 and why you consider it to be "at least as effective as."

**D. Comments**

Fire services are metered; hydrants are not.

**BMP 05: Large Landscape Conservation Programs and Incentives**

Reporting Unit:

Los Angeles Dept. of  
Water and PowerBMP Form Status:  
100% CompleteYear:  
2008**A. Water Use Budgets**

- |  |     |
|--|-----|
| 1. Number of Dedicated Irrigation Meter Accounts:  | 766 |
| 2. Number of Dedicated Irrigation Meter Accounts with Water Budgets:                       | 269 |
| 3. Budgeted Use for Irrigation Meter Accounts with Water Budgets (AF):                     | 0   |
| 4. Actual Use for Irrigation Meter Accounts with Water Budgets (AF):                       | 0   |
| 5. Does your agency provide water use notices to accounts with budgets each billing cycle? | yes |

**B. Landscape Surveys**

- |  |           |
|--|-----------|
| 1. Has your agency developed a marketing / targeting strategy for landscape surveys? | yes       |
| a. If YES, when did your agency begin implementing this strategy?                    | 6/10/1996 |
| b. Description of marketing / targeting strategy:                                    |           |

Work with LA Dept Rec & Parks, school district to audit and provide audit training. All accts applying for landscape incentives also audited. Review consumption history for excess use.

- |  |     |
|--|-----|
| 2. Number of Surveys Offered.  | 6   |
| 3. Number of Surveys Completed.  | 6   |
| 4. Indicate which of the following Landscape Elements are part of your survey: |     |
| a. Irrigation System Check   | yes |
| b. Distribution Uniformity Analysis  | yes |
| c. Review / Develop Irrigation Schedules                                       | yes |
| d. Measure Landscape Area  | yes |
| e. Measure Total Irrigable Area  | yes |
| f. Provide Customer Report / Information                                       | yes |

- 5. Do you track survey offers and results? yes
- 6. Does your agency provide follow-up surveys for previously completed surveys? yes

a. If YES, describe below:

Accounts with poor distribution uniformity re-audited after system improvements completed

**C. Other BMP 5 Actions**

- 1. An agency can provide mixed-use accounts with ETo-based landscape budgets in lieu of a large landscape survey program. no  
Does your agency provide mixed-use accounts with landscape budgets?
- 2. Number of CII mixed-use accounts with landscape budgets. 0
- 3. Do you offer landscape irrigation training? yes
- 4. Does your agency offer financial incentives to improve landscape water use efficiency? yes

Type of Financial Incentive:	Budget (Dollars/Year)	Number Awarded to Customers	Total Amount Awarded
a. Rebates	1000000	1	8538
b. Loans	0	0	0
c. Grants	80000	0	0

- 5. Do you provide landscape water use efficiency information to new customers and customers changing services? No  
a. If YES, describe below:
- 6. Do you have irrigated landscaping at your facilities? yes  
a. If yes, is it water-efficient? yes  
b. If yes, does it have dedicated irrigation metering? yes
- 7. Do you provide customer notices at the start of the irrigation season? no
- 8. Do you provide customer notices at the end of the irrigation season? no

**D. "At Least As Effective As"**

- 1. Is your AGENCY implementing an "at least as effective as" variant of this BMP? Yes  
a. If YES, please explain in detail how your implementation of this BMP differs from Exhibit 1 and why you consider it to be "at least as effective as."

The Los Angeles Department of Water and Power (LADWP) is taking a multi-pronged approach and implementing several programs to target our large landscapes (e.g. parks and schools) and commercial, industrial, and institutional (CII) customers having irrigated landscapes. LADWP implements the ambitious Technical Assistance Program (TAP), which is a custom financial incentive program offering CII and Multi-Family Residential customers in Los Angeles up to \$250,000 for the installation of pre-approved equipment and products (including the design and installation of efficient irrigation systems) that demonstrate persistent water savings. LADWP staff is currently working with a major customer on significant modifications for a new proprietary process that will conserve a considerable amount of water annually. LADWP has entered into a Memorandum of Understanding (MOU) with the Los Angeles

Department of Recreation and Parks (RAP) for the purpose of funding water use efficiency improvements for large landscapes in City parks. These water conservation improvements that LADWP and RAP are working in partnership to advance include installation of weather-based irrigation controllers, high efficiency sprinkler heads, and repair or replacement of irrigation distribution systems. The MOU strengthens LADWP's commitment to conservation as a means of providing a sustainable source of water to the City of Los Angeles as adopted by the Board in the 2005 Urban Water Management Plan. In August of 2008, LADWP amended its Emergency Water Conservation Plan (a City Ordinance) to address the increasing water shortage. The Plan's requirements are applicable to all LADWP customers, and are focused primarily on landscape irrigation. The Plan permits customers to use water only during specified hours of the day and specified days of the week, depending on the declared severity of water shortage. Water allotment varies by each phase (I-VI), such that phase I has the least amount of restrictions and phase VI having the most stringent restrictions. LADWP is currently developing a proposal for "Shortage Year" Water Rates (Tier 1 and Tier 2) for both commercial and residential customers that will become effective in mid-2009. Customers will be required to conserve 15% below their Tier 1 allotment to avoid a bill increase; however, those who exceed their allotment must pay Tier 2 rates resulting in higher water bills. Shortage Year Water Rates are designed to ensure that costs are recovered without penalizing customers who conserve during the years when projected demand for water exceeds the available supply. As has been demonstrated by LADWP's 100% volumetric rate structure, price signal is a most effective conservation tool. In addition to the Ordinance modifications described above, LADWP has developed and is planning to launch a Turf Buy Back Program in 2009. This new program will pay single family residential and commercial customers \$1.00 per square foot of turf removed and replaced with drought tolerant plants, mulch or permeable hardscape. Any subsequent irrigation requirements will be met with low volume drip or microspray emitters. LADWP is also in the process of expanding our recycled water program and are working with water intensive CII customers such as golf courses, parks, and refineries to promote and use recycled water. LADWP is currently converting all of our golf courses and parks to dedicated irrigation meters for the usage of recycled water. Our recycled water goal is to deliver at least 50,000 acre-feet per year by 2019. This will be done by expanding the "purple pipe" distribution system to new customers who can use recycled water for non-potable uses such as irrigation and industrial processes.

#### **E. Comments**

Reported as of 6/10/10

### **BMP 06: High-Efficiency Washing Machine Rebate Programs**

Reporting Unit:	BMP Form Status:	Year:
<b>Los Angeles Dept. of Water and Power</b>	<b>100% Complete</b>	<b>2008</b>

#### **A. Implementation**

1. Do any energy service providers or waste water utilities in your service area offer rebates for high-efficiency washers?
  - a. If YES, describe the offerings and incentives as well as who the



energy/waste water utility provider is.

- 2. Does your agency offer rebates for high-efficiency washers? yes
- 3. What is the level of the rebate?
- 4. Number of rebates awarded.

**B. Rebate Program Expenditures**

**This Year   Next Year**

- 1. Budgeted Expenditures
- 2. Actual Expenditures

**C. "At Least As Effective As"**

- 1. Is your AGENCY implementing an "at least as effective as" variant of this BMP? no
  - a. If YES, please explain in detail how your implementation of this BMP differs from Exhibit 1 and why you consider it to be "at least as effective as."

**D. Comments**

Reported as of 6/10/10

**BMP 07: Public Information Programs**

Reporting Unit: **Los Angeles Dept. of Water and Power**      BMP Form Status: **100% Complete**      Year: **2008**

**A. Implementation**

- 1. How is your public information program implemented?  
Wholesaler and retailer both materially participate in program  
Which wholesaler(s)?  
Metropolitan Water District of Southern California
- 2. Describe the program and how it's organized:  
LADWP's Public Affairs Division works closely with the Water Conservation office. Information is made available on LADWP Web site, conservation publications distributed at public venues and by request (in English and Spanish); customer newsletter; Speakers Bureau and school presentations; fleet vehicle signage; posters and brochures in LADWP Customer Service Centers and City Council field offices; permanent water display located at Olvera Street, a popular Los Angeles landmark and tourist venue; a special flier regarding conservation was produced and inserted for distribution in the Los Angeles Times and Daily News in English and in Impacto in Spanish. Print advertisements were placed twice monthly beginning in November of 2005 and terminating December 2006 in various languages in the community press and major daily newspapers serving Los Angeles to Promote awareness of and participation in LADWP's residential water conservation programs. The LADWP Public Affairs Division prepares an outreach program annually based on the specific program needs of the Water Conservation office. Public Affairs implements the elements of the program which include development and production of collateral materials and exhibits; development and placement of all advertisements and public service announcements; development and posting of Web site announcements. MWDSC independently promotes conservation through various media channels and directly promotes programs via the bewaterwise.com website as well as by its program

implementation contractor

3. Indicate which and how many of the following activities are included in your public information program:

Public Information Program Activity In Retail Service Area	Yes/No	Number of Events
a. Paid Advertising	yes	250
b. Public Service Announcement	no	
c. Bill Inserts / Newsletters / Brochures	yes	22
d. Bill showing water usage in comparison to previous year's usage	yes	
e. Demonstration Gardens	no	
f. Special Events, Media Events	yes	3
g. Speaker's Bureau	yes	10
h. Program to coordinate with other government agencies, industry and public interest groups and media	yes	

**B. Conservation Information Program Expenditures**

1. Annual Expenditures (Excluding Staffing)

**C. "At Least As Effective As"**

1. Is your AGENCY implementing an "at least as effective as" variant of this BMP? No

a. If YES, please explain in detail how your implementation of this BMP differs from Exhibit 1 and why you consider it to be "at least as effective as."

**D. Comments**

Reported as of 6/10/10

**BMP 08: School Education Programs**

Reporting Unit:

**Los Angeles Dept. of Water and Power**

BMP Form Status:  
**100% Complete**

Year:  
**2008**

**A. Implementation**

1. How is your public information program implemented?

Retailer runs program without wholesaler sponsorship

2. Please provide information on your region-wide school programs (by grade level):

Grade	Are grade-appropriate materials distributed?	No. of class presentations	No. of students reached	No. of teachers' workshops
Grades K-3rd	yes	0	0	0
Grades 4th-6th	yes	0	3600	0
Grades 7th-8th	yes	0	18500	0
High School	yes	0	29500	0

- 4. Did your Agency's materials meet state education framework requirements? yes
- 5. When did your Agency begin implementing this program? 09/15/1975

**B. School Education Program Expenditures**

- 1. Annual Expenditures (Excluding Staffing)

**C. "At Least As Effective As"**

- 1. Is your AGENCY implementing an "at least as effective as" variant of this BMP? No
  - a. If YES, please explain in detail how your implementation of this BMP differs from Exhibit 1 and why you consider it to be "at least as effective as."

**D. Comments**

Teachers' guide and supporting materials funded and/or provided by LADWP. Dedicated LADWP staff coordinate with school district throughout the school year.

Reported as of 6/10/10

**BMP 09: Conservation Programs for CII Accounts**

Reporting Unit:	BMP Form Status:	Year:
<b>Los Angeles Dept. of Water and Power</b>	<b>100% Complete</b>	<b>2008</b>

**A. Implementation**

- 1. Has your agency identified and ranked COMMERCIAL customers according to use? yes
- 2. Has your agency identified and ranked INDUSTRIAL customers according to use? yes
- 3. Has your agency identified and ranked INSTITUTIONAL customers according to use? yes

**Option A: CII Water Use Survey and Customer Incentives Program**

- 4. Is your agency operating a CII water use survey and customer incentives program for the purpose of complying with BMP 9 under this option? If so, please describe activity during reporting period: yes

CII Surveys	Commercial Accounts	Industrial Accounts	Institutional Accounts
a. Number of New Surveys Offered	15	7	4
b. Number of New Surveys Completed	15	7	4
c. Number of Site Follow-ups of Previous Surveys (within 1 yr)	6	4	1
d. Number of Phone Follow-ups of Previous Surveys (within 1 yr)	6	2	1
<b>CII Survey Components</b>	<b>Commercial</b>	<b>Industrial</b>	<b>Institutional</b>

	Accounts	Accounts	Accounts
e. Site Visit	yes	yes	yes
f. Evaluation of all water-using apparatus and processes	yes	yes	yes
g. Customer report identifying recommended efficiency measures, paybacks and agency incentives	yes	yes	yes
<b>Agency CII Customer Incentives</b>	<b>Budget (\$/Year)</b>	<b># Awarded to Customers</b>	<b>Total \$ Amount Awarded</b>
h. Rebates	1500000	6605	925931
i. Loans	0	0	0
j. Grants	350000	0	0
k. Others	0	0	0

**Option B: CII Conservation Program Targets**

5. Does your agency track CII program interventions and water savings for the purpose of complying with BMP 9 under this option? yes

6. Does your agency document and maintain records on how savings were realized and the method of calculation for estimated savings? yes

**7. System Calculated annual savings (AF/yr):**

CII Programs	# Device Installations
a. Ultra Low Flush Toilets	1127
b. Dual Flush Toilets	525
c. High Efficiency Toilets	1721
d. High Efficiency Urinals	1327
e. Non-Water Urinals	346
f. Commercial Clothes Washers (coin-op only; not industrial)	835
g. Cooling Tower Controllers	26
h. Food Steamers	13
i. Ice Machines	0
j. Pre-Rinse Spray Valves	2
k. Steam Sterilizer Retrofits	5
l. X-ray Film Processors	0

**8. Estimated annual savings (AF/yr) from agency programs not including the devices listed in Option B. 7., above:**

CII Programs	Annual Savings (AF/yr)
a. Site-verified actions taken by agency:	0
b. Non-site-verified actions taken by agency:	0

**B. Conservation Program Expenditures for CII Accounts**

**This Year      Next Year**

1. Budgeted Expenditures	2750000	2750000
2. Actual Expenditures	925931	

**C. "At Least As Effective As"**

1. Is your agency implementing an "at least as effective as" variant of this BMP? No

a. If YES, please explain in detail how your implementation of this BMP differs from Exhibit 1 and why you consider it to be "at least as effective as."

**D. Comments****BMP 11: Conservation Pricing**

Reporting Unit:

Los Angeles Dept. of Water  
and PowerBMP Form Status:  
100% CompleteYear:  
2008**A. Implementation****Water Service Rate Structure Data by Customer Class****1. Single Family Residential**

a. Rate Structure	Increasing Block Seasonal
b. Total Revenue from Commodity Charges (Volumetric Rates)	\$ 299,536,198
c. Total Revenue from Customer Meter/Service (Fixed) Charges	\$ ,

**2. Multi-Family Residential**

a. Rate Structure	Increasing Block Seasonal
b. Total Revenue from Commodity Charges (Volumetric Rates)	\$ 216,210,111
c. Total Revenue from Customer Meter/Service (Fixed) Charges	\$ 0

**3. Commercial**

a. Rate Structure	Increasing Block Seasonal
b. Total Revenue from Commodity Charges (Volumetric Rates)	\$ 138,218,700
c. Total Revenue from Customer Meter/Service (Fixed) Charges	\$ 0

**4. Industrial**

a. Rate Structure	Increasing Block Seasonal
b. Total Revenue from Commodity Charges (Volumetric Rates)	\$ 30,670,561
c. Total Revenue from Customer Meter/Service (Fixed) Charges	\$ 0

**5. Institutional / Government**

a. Rate Structure	Increasing Block Seasonal
b. Total Revenue from Commodity Charges (Volumetric Rates)	\$ 36,762,959
c. Total Revenue from Customer Meter/Service (Fixed) Charges	\$ 0

<b>6. Dedicated Irrigation (potable)</b>	
a. Rate Structure	Increasing Block Seasonal
b. Total Revenue from Commodity Charges (Volumetric Rates)	\$ 7,965,994
c. Total Revenue from Customer Meter/Service (Fixed) Charges	\$ 0
<b>7. Recycled-Reclaimed</b>	
a. Rate Structure	Uniform
b. Total Revenue from Commodity Charges (Volumetric Rates)	\$ 1,679,516
c. Total Revenue from Customer Meter/Service (Fixed) Charges	\$ 0
<b>8. Raw</b>	
a. Rate Structure	Service Not Provided
b. Total Revenue from Commodity Charges (Volumetric Rates)	\$ 0
c. Total Revenue from Customer Meter/Service (Fixed) Charges	\$ 0
<b>9. Other</b>	
a. Rate Structure	Service Not Provided
b. Total Revenue from Commodity Charges (Volumetric Rates)	\$ 0
c. Total Revenue from Customer Meter/Service (Fixed) Charges	\$ 0

**B. Implementation Options**

**Select Either Option 1 or Option 2:**

**1. Option 1: Use Annual Revenue As Reported**  
 $V/(V+M) \geq 70\%$

V = Total annual revenue from volumetric rates  
M = Total annual revenue from customer meter/service (fixed) charges

Selected

**2. Option 2: Use Canadian Water & Wastewater Association Rate Design Model**

$V/(V+M) \geq V'/(V'+M')$   
V = Total annual revenue from volumetric rates  
M = Total annual revenue from customer meter/service (fixed) charges

V' = The uniform volume rate based on the signatory's long-run incremental cost of service  
M' = The associated meter charge

- a. If you selected Option 2, has your agency submitted to the Council a completed Canadian Water & Wastewater Association rate design model?
- b. Value for V' (uniform volume rate based on agency's long-run incremental cost of service) as determined by the Canadian Water & Wastewater Association rate design model:
- c. Value for M' (meter charge associated with V' uniform volume rate) as determined by the Canadian Water & Wastewater Association rate design model:

**C. Retail Wastewater (Sewer) Rate Structure Data by Customer Class**

1. Does your agency provide sewer service? (If YES, answer questions 2 - 7 below, else continue to section D.)

No

**2. Single Family Residential**

a. Sewer Rate Structure

b. Total Annual Revenue \$ 0

c. Total Revenue from  
Commodity Charges  
(Volumetric Rates) \$ 0

**3. Multi-Family Residential**

a. Sewer Rate Structure

b. Total Annual Revenue \$ 0

c. Total Revenue from  
Commodity Charges  
(Volumetric Rates) \$ 0

**4. Commercial**

a. Sewer Rate Structure

b. Total Annual Revenue \$ 0

c. Total Revenue from  
Commodity Charges  
(Volumetric Rates) \$ 0

**5. Industrial**

a. Sewer Rate Structure

b. Total Annual Revenue \$ 0

c. Total Revenue from  
Commodity Charges  
(Volumetric Rates) \$ 0

**6. Institutional / Government**

a. Sewer Rate Structure

b. Total Annual Revenue \$ 0

c. Total Revenue from  
Commodity Charges  
(Volumetric Rates) \$ 0

**7. Recycled-reclaimed water**

a. Sewer Rate Structure

b. Total Annual Revenue \$ 0

c. Total Revenue from  
Commodity Charges  
(Volumetric Rates) \$ 0

**D. "At Least As Effective As"**

1. Is your agency implementing an "at least as effective as" variant of this BMP?

No

a. If YES, please explain in detail how your implementation of this BMP differs from Exhibit 1 and why you consider it to be "at least as effective as."

**E. Comments**

Link to LADWP Water Rate Ordinance:  
<http://www.ladwp.com/ladwp/cms/ladwp001149.pdf>

**BMP 12: Conservation Coordinator**

Reporting Unit:

**Los Angeles Dept. of Water and Power**

BMP Form Status:

**100% Complete**

Year:

**2008****A. Implementation**

1. Does your Agency have a conservation coordinator? yes
2. Is a coordinator position supplied by another agency with which you cooperate in a regional conservation program ? no
  - a. Partner agency's name:
3. If your agency supplies the conservation coordinator:
  - a. What percent is this conservation coordinator's position? 100%
  - b. Coordinator's Name Thomas Gackstetter
  - c. Coordinator's Title Water Conservation Manager
  - d. Coordinator's Experience and Number of Years 21
  - e. Date Coordinator's position was created (mm/dd/yyyy) 12/11/1991
4. Number of conservation staff (FTEs), including Conservation Coordinator. 5

**B. Conservation Staff Program Expenditures**

1. Staffing Expenditures (In-house Only) 609562
2. BMP Program Implementation Expenditures 6989200

**C. "At Least As Effective As"**

1. Is your AGENCY implementing an "at least as effective as" variant of this BMP? no
  - a. If YES, please explain in detail how your implementation of this BMP differs from Exhibit 1 and why you consider it to be "at least as effective as."

**D. Comments****BMP 13: Water Waste Prohibition**

Reporting Unit:

**Los Angeles Dept. of Water and Power**

BMP Form Status:

**100% Complete**

Year:

**2008****A. Requirements for Documenting BMP Implementation**

1. Is a water waste prohibition ordinance in effect in your service area? yes
  - a. If YES, describe the ordinance:
 

Prohibits use of water on hardscape, gutter flooding, unattended leaks, mid-day watering, serving water in restaurants w/o request, non recirc fountains
2. Is a copy of the most current ordinance(s) on file with CUWCC? yes
  - a. List local jurisdictions in your service area in the first text box and water waste ordinance citations in each jurisdiction in the second text



box:

City of Los Angeles

Ord No. 166080

**B. Implementation**

1. Indicate which of the water uses listed below are prohibited by your agency or service area.

- a. Gutter flooding yes
- b. Single-pass cooling systems for new connections Yes
- c. Non-recirculating systems in all new conveyor or car wash systems Yes
- d. Non-recirculating systems in all new commercial laundry systems Yes
- e. Non-recirculating systems in all new decorative fountains yes
- f. Other, please name yes  
See above

2. Describe measures that prohibit water uses listed above:

Specific ordinance language, monetary penalties, service restrictions/shutoff. Cost of water/wastewater and common practice limits number of single pass systems

**Water Softeners:**

3. Indicate which of the following measures your agency has supported in developing state law:

- a. Allow the sale of more efficient, demand-initiated regenerating DIR models. no
- b. Develop minimum appliance efficiency standards that:
  - i.) Increase the regeneration efficiency standard to at least 3,350 grains of hardness removed per pound of common salt used. no
  - ii.) Implement an identified maximum number of gallons discharged per gallon of soft water produced. no
- c. Allow local agencies, including municipalities and special districts, to set more stringent standards and/or to ban on-site regeneration of water softeners if it is demonstrated and found by the agency governing board that there is an adverse effect on the reclaimed water or groundwater supply. no

4. Does your agency include water softener checks in home water audit programs? no

5. Does your agency include information about DIR and exchange-type water softeners in educational efforts to encourage replacement of less efficient timer models? no

**C. "At Least As Effective As"**

1. Is your AGENCY implementing an "at least as effective as" variant of this BMP? no

a. If YES, please explain in detail how your implementation of this BMP differs from Exhibit 1 and why you consider it to be "at least as effective as."

**D. Comments**

**BMP 14: Residential ULFT Replacement Programs**

Reporting Unit:  
**Los Angeles Dept. of Water and Power**

BMP Form Status: **100% Complete**  
 Year: **2008**

**A. Implementation**

**Number of 1.6 gpf Toilets Replaced by Agency Program During Report Year**

	Single-Family Accounts	Multi-Family Units
1. Does your Agency have program(s) for replacing high-water-using toilets with ultra-low flush toilets?	yes	yes
<b>Replacement Method</b>	<b>SF Accounts</b>	<b>MF Units</b>
2. Rebate	0	42
3. Direct Install	0	0
4. CBO Distribution	0	0
5. Other	0	0
<b>Total</b>	<b>0</b>	<b>42</b>

**Number of 1.2 gpf High-Efficiency Toilets (HETs) Replaced by Agency Program During Report Year**

	Single-Family Accounts	Multi-Family Units
6. Does your Agency have program(s) for replacing high-water-using toilets with ultra-low flush toilets?	no	no
<b>Replacement Method</b>	<b>SF Accounts</b>	<b>MF Units</b>
7. Rebate		
8. Direct Install		
9. CBO Distribution		
10. Other		
<b>Total</b>		

**Number of Dual-Flush Toilets Replaced by Agency Program During Report Year**

	Single-Family Accounts	Multi-Family Units
11. Does your Agency have program(s) for replacing high-water-using toilets with ultra-low flush toilets?	no	no
<b>Replacement Method</b>	<b>SF Accounts</b>	<b>MF Units</b>
12. Rebate	0	0
13. Direct Install	0	0
14. CBO Distribution	0	0
15. Other	0	0
<b>Total</b>	<b>0</b>	<b>0</b>

16. Describe your agency's ULFT, HET, and/or Dual-Flush Toilet programs for

single-family residences.

Residential ULFT rebate and distribution programs ended in 2007.

17. Describe your agency's ULFT, HET, and/or Dual-Flush Toilet programs for multi-family residences.

Residential ULFT rebate and distribution programs ended in 2007.

18. Is a toilet retrofit on resale ordinance in effect for your service area? yes

19. List local jurisdictions in your service area in the left box and ordinance citations in each jurisdiction in the right box:

City of Los Angeles

Ord. No. 172075

### B. Residential ULFT Program Expenditures

1. Estimated cost per ULFT/HET replacement: 242.86

### C. "At Least As Effective As"

1. Is your AGENCY implementing an "at least as effective as" variant of this BMP? no

a. If YES, please explain in detail how your implementation of this BMP differs from Exhibit 1 and why you consider it to be "at least as effective as."

### D. Comments

DEPARTMENT OF WATER AND POWER  
CITY OF LOS ANGELES

COMMISSION OFFICE

May 2, 2005

JAMES B. MCDANIEL  
Chief Operating Officer – Water System  
Room 1455,JFB

Attached herewith is an ORIGINAL AND DUPLICATE ORIGINAL OF AGREEMENT

FOR SIGNATURE. RETURN FULLY EXECUTED ORIGINAL TO THE COMMISSION OFFICE,

ROOM 1555. THE DUPLICATE ORIGINAL SHOULD BE RETAINED BY THE CONTRACTOR.

FILE NO.	DATE	NAME
	06-17-03	Los Angeles Department of Recreation and Parks – Memorandum of Understanding – Authorizes providing for the transfer of ownership of the pre-existing Griffith Park Water System to the DWP. Authorized by Resolution No. 003-288, adopted June 17, 2003. Approved under Council File No. 03-1331, on April 19, 2005.
	5/3/05	Marty Adams for further processing of Original and Duplicate original of MOU and return of fully executed Original to the Water Executive Office. Upon receipt, WEX will forward to the Board Office.
	6/15/05	Orlinda Abraham - Return of fully executed original MOU. c: Marty Adams Anselmo Collins

  
BARBARA E. MOSCHOS  
Title Board Secretary

BOARD OF RECREATION AND  
PARK COMMISSIONERS

MIKE ROOS  
PRESIDENT

CHRISTINA SANCHEZ-CAMINO  
VICE PRESIDENT

CHRISTOPHER W. HAMMOND  
MARY LUÉVANO  
CANDY SPELLING

CITY OF LOS ANGELES

CALIFORNIA



JAMES K. HAHN  
MAYOR

May 16, 2005

DEPARTMENT OF  
RECREATION AND PARKS

1200 W. 7<sup>TH</sup> ST.  
SUITE 762  
LOS ANGELES, CA 90017

(213) 928-9040  
FAX - (213) 928-9048

JON KIRK MUKRI  
GENERAL MANAGER

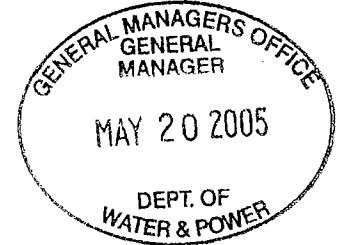
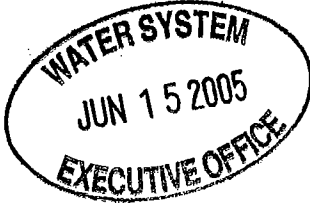

Ronald F. Deaton, General Manager  
Department of Water and Power  
111 North Hope Street  
Los Angeles, CA 90012

Attention: Anselmo G. Collins  
Water Master Planning Manager  
111 North Hope Street, Ste. 1348  
Los Angeles, CA 90012-5701

Dear Mr. Deaton:

Enclosed is the original Memorandum of Understanding (MOU),  
executed on May 5, 2005 between the Departments of Water and  
Power and Recreation and Parks for the transfer of ownership for  
the Griffith Park Water System.

Very truly yours,

BOARD OF RECREATION AND  
PARK COMMISSIONERS

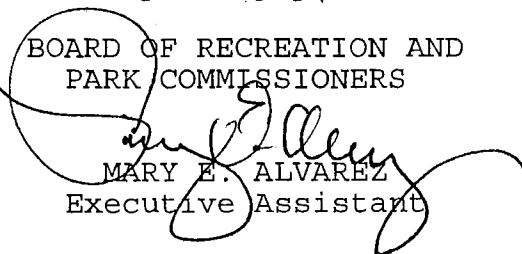
  
MARY E. ALVAREZ  
Executive Assistant

Enclosure

cc: City Attorney  
Grants Accounting  
City Controller (w/attachment)  
Kevin Regan (w/attachment)

ORIGINAL

**MEMORANDUM OF UNDERSTANDING  
BETWEEN THE DEPARTMENT OF WATER AND POWER  
AND  
THE DEPARTMENT OF RECREATION AND PARKS  
OF THE CITY OF LOS ANGELES  
CONCERNING THE TRANSFER OF OWNERSHIP OF THE  
GRIFFITH PARK WATER SYSTEM**

---

THIS MEMORANDUM OF UNDERSTANDING, hereinafter referred to as MOU, is made and entered into by and between the Los Angeles Department of Water and Power (LADWP) and the Department of Recreation and Parks (RAP) of the City of Los Angeles acting by and through the Board of Water and Power Commissioners and the Board of Recreation and Parks Commissioners, respectively.

WHEREAS, by previous MOU adopted by the Board of Water and Power Commissioners Resolution No. 99019 and the Board of Recreation and Parks Commissioners action on Report 282-98, the LADWP has taken over operation and maintenance of the pre-existing Griffith Park Water System (Existing System), management of RAP personnel operating the Existing System, and has provided RAP with ongoing assistance responding to regulatory requests regarding system water quality; and

WHEREAS, the goal of the existing MOU was to ensure reliability and regulatory compliance of the Existing System while the LADWP constructed a replacement Griffith Park Water System (New System) that would be owned and operated by the LADWP and that would relieve RAP from all responsibilities of owning or operating in Griffith Park a Public Water System as defined by the State of California Department of Health Services (DHS); and

WHEREAS, the LADWP has completed the installation of a substantial portion of the New System and placed such system in service and in accordance with the previous MOU and the goal of the Griffith Park Water System Replacement Project all facilities installed or to be installed are owned, operated, and under the sole control and responsibility of the LADWP; and

WHEREAS, the extensive interconnection between completed or soon-to-be completed portions of the New System and the Existing System makes it timely and appropriate to conclude the intended transfer of the full ownership and responsibility for the delivery of water in Griffith Park to the LADWP, which is the appropriate agency in the City that owns and manages Public Water Systems; and

WHEREAS, RAP supports the immediate transfer of ownership of the Existing System to the LADWP and the LADWP is willing to accept such ownership and sole responsibility for the Public Water System in Griffith Park;

NOW, THEREFORE, for and in consideration of the covenants and conditions contained herein and the performance thereof, the parties hereto mutually agree as follows:

1. RAP conveys and the LADWP assumes ownership and complete operational control of and responsibility for all components of the Existing Griffith Park Water System as listed in Attachment A, including: pipelines, pumping stations, water storage tanks, and other appurtenant facilities; system operations, maintenance, repair, and emergency response; and, water quality operations, monitoring, and reporting. Upon execution of this MOU and throughout the remainder of this document, all Existing System facilities conveyed to the LADWP will be regarded as part of the New System constructed to serve Griffith Park. RAP shall have no authority or obligation for the operation and maintenance of New System facilities in Griffith Park.
2. RAP will retain ownership of Existing System facilities as listed in Attachment B. These non-conveyed facilities will continue to be operated and maintained by the LADWP at no cost to RAP until such time that the LADWP notifies RAP in writing that these facilities are no longer required and will be abandoned. After such time, it will be the sole responsibility of RAP to determine and execute the proper disposition of abandoned facilities of the Existing System.
3. RAP will continue to own, operate, and maintain in accordance with all applicable health standards its domestic, irrigation, and fire systems after its metered and/or unmetered connection(s) to the LADWP water mains. RAP shall be responsible for testing and maintaining backflow prevention assemblies in accordance with Water Service Rule 16-D and all applicable state and federal regulations.
4. RAP will continue to have full responsibility for plumbing changes required on the customer side of each metered and/or unmetered service connection to transfer Griffith Park water usage from the Existing System to the New System. In order to eliminate reliance on the Existing System for domestic and fire supply, connections to the New System and associated plumbing changes will be made within 90 calendar days of written notification that a New System replacement water main has been completed and is in service.
5. RAP will no longer be financially responsible for the operation of or facilities within the Existing System in any way, including energy costs at Existing System pump stations, but not including the purchase cost of water used in Griffith Park. At such time that the LADWP informs RAP in writing that specific facilities have been abandoned, RAP will resume responsibility for these facilities in accordance with Article 2 above.

6. Responsibility for meeting DHS water quality standards in the Griffith Park Public Water System will be transferred from RAP to the LADWP. The LADWP will amend its Water Supply Permit with DHS to reflect this.
7. RAP shall continue to be metered and billed through the General Services Department, for all water conveyed to and served in Griffith Park.
8. RAP agrees to transfer and the LADWP agrees to accept, in accordance with the Los Angeles City Charter Section 1014, the RAP personnel listed in Attachment C who currently oversee the operation, maintenance, repair, and monitoring of the Existing System. RAP will no longer be required to retain such personnel positions on their APR. Personnel will be permanently transferred to civil service classes commensurate with their current civil service classes and job duties and experience. RAP personnel currently assigned to operation, maintenance, or repair of the Existing System and not listed for transfer will be re-assigned in their same civil service classifications to vacant positions in RAP.
9. All RAP tools, materials, portable pumps, vehicles and equipment, storage containers, etc. dedicated to the operation, patrol, repair, and maintenance of the Existing System will be conveyed to the LADWP at no cost as listed in Attachment D.
10. All Griffith Park lands will remain RAP property, but the LADWP has permission to use the real property specified on Existing System and New System drawings for water facilities, including tanks, pump stations, regulator stations, water treatment stations, associated structures, and pipeline right-of-ways. The nature and character of the real property comprising the New System as a park or recreational site shall not be affected by this MOU and said real property shall continue to be subject to the provisions of City Charter Section 590.
11. RAP will cooperate fully with the LADWP in its maintenance, repair, and operation of existing New System facilities and in siting and constructing additional facilities. RAP agrees to support and assist the LADWP in its efforts to complete facilities required for the New System and in obtaining necessary approvals from environmental groups, concerned citizens, and other interested parties. RAP shall grant to the LADWP all permissions necessary to ensure the proper restoration, relocation, upgrade, repair, maintenance, and operation of facilities of the New System. Such permissions shall not be revoked without the express, written consent of the LADWP. RAP will consult with the LADWP prior to realignment and/or relocation of roadways or installation of structures above or adjacent to New System facilities.



12. The LADWP shall have unlimited right of entry to all areas of Griffith Park. In addition, RAP shall make every reasonable and timely effort to maintain in a safe and passable condition all dirt roads and trails that contain or provide access to New System facilities and those Existing System facilities still in service.

IN WITNESS WHEREOF, the parties hereto have caused this MOU to be executed by their authorized representatives on the day and year written below.

DEPARTMENT OF WATER AND POWER OF  
THE CITY OF LOS ANGELES BY  
BOARD OF WATER AND POWER COMMISSIONERS OF  
THE CITY OF LOS ANGELES

Date: 4/29/05

By: Ronald F. Deaton  
Ronald F. Deaton, General Manager

And: Rose A. Garcia  
ASSISTANT Secretary

DEPARTMENT OF RECREATION AND PARKS OF  
THE CITY OF LOS ANGELES BY  
BOARD OF RECREATION AND PARKS COMMISSIONERS OF  
THE CITY OF LOS ANGELES

Date: 5/5/05

By: [Signature]

And: [Signature]  
Secretary

Approved as to Form

APPROVED AS TO FORM AND LEGALITY  
ROCKARD J. DELGADILLO, CITY ATTORNEY

5-5, 2005  
ROCKARD J. DELGADILLO, City Attorney

JUN 04 2003  
BY [Signature]  
S. DAVID HOTCHKISS  
Assistant City Attorney

By [Signature]

AUTHORIZED BY RES. 003.288  
JUN 17 2003

## **Attachment A**

### **Existing System Facilities to be Transferred to DWP**

- All existing pipelines, up to and including service shutoff valves and service meters
- Zoo Pump Station
- Travel Town Pump Station
- Crystal Springs Pump Station
- Toyon Pump Station
- Zoo Tank
- Tank 72
- Tank 151
- Reclaimed Water Tank
- Toyon Tank
- Well #7

## Attachment B

### Existing System Facilities Not Transferred to DWP

#### Tanks

"G"

73

74

75

111

112

113

114

115

116

153

#### Pump Stations

"G"

73

75

111

112

113

114

#### Plumbing

- Customer-side facilities after both meters and/or unmetered service connection shutoff valves
- Customer-side back flow prevention devices

**Attachment C**

**RAP Employees to be Transferred to DWP**

Larry Patrich – Mechanical Repair Supervisor

Ed Pushich – Electrical Pump Plant Operator

Phillip Palomo – Gardener/Caretaker

## **Attachment D**

### **List of Tools and Equipment to be Transferred**

All hand tools and electric tools routinely housed at Existing System facilities and/or on vehicles used by RAP personnel permanently assigned to operation, maintenance, and/or repair of the Griffith Park Water System.

Vermeer trencher assigned to the Griffith Park Water System and housed at the Crystal Springs Pump House.

All pumps, pipes, valves, and appurtenant materials located at Existing System facilities and used for the operation, maintenance, and/or repair of the Griffith Park Water System.

# APPENDIX I

## Enhancement Project – Tujunga Spreading Grounds – Los Angeles Department of Water and Power

1                                    ROSCOE DRAIN RELOCATION  
2                                    AND SPREADING AT  
3                                    TUJUNGA SPREADING GROUNDS  
4                                    AGREEMENT NO. 10400

62688

DUPLICATE  
ORIGINAL

5                    THIS AGREEMENT, is made and entered into by and between the COUNTY OF  
6 LOS ANGELES, hereinafter referred to as "County"; the LOS ANGELES COUNTY  
7 FLOOD CONTROL DISTRICT, hereinafter referred to as "District"; and the  
8 DEPARTMENT OF WATER AND POWER of the City of Los Angeles, hereinafter  
9 referred to as "Department".

10                                    RECITALS

11                    A. Department owns, operates and controls certain spreading grounds  
12 and incidental facilities in the City of Los Angeles in the vicinity of the  
13 intersection of the Hollywood Freeway and Roscoe Boulevard known as Tujunga  
14 Spreading Grounds; (hereinafter referred to as "the Spreading Grounds");  
15 and

16                    B. County is administering this Agreement for District pursuant to  
17 Los Angeles County Charter Section 56 3/4 and the Agreement between County  
18 and District dated December 26, 1984; and

19                    C. County operates storm water collection facilities tributary to the  
20 Tujunga Wash upstream of the Spreading Grounds in which are collected storm  
21 water runoff; and

22                    D. County is authorized, under Section 2 of the Los Angeles County  
23 Flood Control Act, as amended, "to provide for the control and conservation  
24 of the flood, storm and other waste waters of said district, and to con-  
25 serve such for beneficial and useful purposes by spreading, storing,  
26 retaining, or causing to percolate into the soil within said district, or  
27 to save or conserve in any manner, all or any such water..."; and

28                    E. There are times when the Spreading Grounds are not fully required

Rec'd

JUL 30 1990

1 to spread Department's water resulting in excess spreading capacity  
2 available to the County; and

3 F. County, at times, has water available which it wishes to spread in  
4 the Spreading Grounds at no cost to the Department; and

5 G. Department, at times, has water available which it wishes to have  
6 County spread in the Spreading Grounds at no cost to the Department; and

7 H. County and Department agree there are mutual benefits associated  
8 with spreading local storm water runoff in the Spreading Grounds and  
9 Department wishes to make excess capacity available to the County for  
10 spreading; and

11 I. Department desires that County relinquish its interest in that  
12 storm water detention basin and spreading facility on or near the Tujunga  
13 Spreading Grounds, more particularly described in Agreement Number 41331,  
14 which agreement provided for County to build and operate said storm water  
15 detention basin on Department-owned property on or near the Tujunga  
16 Spreading Grounds and which granted County certain rights of use in the  
17 property and facilities appurtenant thereto. Said property is now required  
18 by the Department as a new facility site, and County is willing to remove  
19 said facility and replace a portion of its functions with a conduit and  
20 appurtenant facilities, hereinafter referred to as "the CONDUIT", to  
21 Tujunga Wash; and

22 J. County can deliver water from the Tujunga Wash to the Spreading  
23 Grounds, if and when diversion facilities are made operational as described  
24 hereafter. All diversion controls, facilities and improvements are to be  
25 owned by the Department; and

26 K. Operation of diversion facilities requires a new rubber dam to be  
27 constructed in addition to repairs and/or installation of appurtenant faci-  
28 lities; and



1 L. Both County and Department recognize that storm water spreading at  
2 the spreading grounds likely will result in silting of the basins and  
3 attendant decreased infiltration rates; and

4 M. Construction costs as used hereinafter includes the actual cost of  
5 construction plus the cost of acquiring necessary rights of way to carry  
6 out the construction program for the CONDUIT.

7 THEREFORE, the parties agree as follows:

8 CONSTRUCTION

9 1. Agreement Number 41331, attached hereto as Exhibit A, is  
10 herewith terminated by this agreement and is of no further force or  
11 effect. Said termination shall become effective after construction of  
12 the CONDUIT and the rubber dam and appurtenant facilities described in  
13 paragraph 3(c) are complete.

14 2. County will, in accordance with County's best engineering  
15 practices, plan, design, acquire necessary right of way and construct  
16 the CONDUIT, in accordance with the following terms:

17 (a) Abandon to the Department the basin property described in  
18 Agreement Number 41311 on or about May 15, 1990, except for those  
19 facilities referenced in paragraph 3(b).

20 (b) Secure a contract to construct the CONDUIT in accordance  
21 with County's standard bidding practices.

22 (c) Administer the contract, and verify the accuracy of  
23 invoices prior to payment.

24 (d) Periodically, as reasonable, submit a request to the  
25 Department for payment of the Department's share of the construc-  
26 tion costs in compliance with this agreement. County will certify  
27 and the Department will pay those invoices that are in compliance  
28 with this agreement. County will provide Department with copies

1 of all invoices.

2 (e) Inspect the construction for the purposes of assuring  
3 adherence to contract specifications.

4 (f) Perform all planning design, inspection and contract  
5 administration functions at County's sole expense.

6 (g) Pay \$200,000 of the construction cost toward construc-  
7 tion of the CONDUIT.

8 (h) Complete construction by October 15, 1990.

9 3. Department will:

10 (a) Pay full construction costs to construct the CONDUIT  
11 exceeding \$200,000, but Department is not required to pay more  
12 than \$1,500,000 except as provided in paragraph four (4).

13 (b) Department herewith issues to County a license incor-  
14 porating the terms of this agreement for necessary construction,  
15 operation and maintenance of the physical facilities in connection  
16 with CONDUIT at no cost to County. Said license shall be for a  
17 term of five (5) years, shall be personal to the County and shall  
18 be for the nonexclusive use by County of the real property and the  
19 facilities constructed or to be constructed thereon, as shown on  
20 County Drawing No. 536-D3.7 and D3.8 (attached hereto as Exhibit B),  
21 for the purposes above, including ingress and egress.

22 (c) Diligently process and recommend to the Los Angeles City  
23 Council the grant of permanent easement(s) to County to carry out  
24 the activities specified in paragraph 3(b) above. The easement(s)  
25 shall be at no cost to County. County shall survey and prepare  
26 those legal descriptions and easement deed(s) required after  
27 completion of construction as provided herein. Such easement  
28 documents shall be submitted to Department for its review

1 and approval prior to submission to City Council for action.

2 (d) Construct and/or reconstruct the rubber dam and appur-  
3 tenant facilities located in Tujunga Wash and at the Spreading  
4 Grounds so that said dam and facilities will fulfill the purpose  
5 of diverting water from the Tujunga Wash to the Spreading Grounds.  
6 All such facilities shall be operational no later than October 15,  
7 1990 and remain operational throughout term of the agreement.

8 4. In the event the contract construction cost exceeds  
9 \$1,700,000, the County and the Department will share the contract  
10 construction cost above \$1,700,000 equally.

11 5. Invoices to the Department should be addressed as follows:

12 Engineer in Charge

13 Water Operating Division

14 Department of Water & Power

15 P. O. Box 111, Room 1420

16 Los Angeles, California 90051

17 OPERATION

18 6. County will operate the diversion facilities and the  
19 Spreading Grounds in accordance with the following terms:

20 (a) Provide all personnel necessary to carry out the safe  
21 and proper operation of the diversion and Spreading Basin  
22 facilities.

23 (b) Under non-storm conditions notify the Department that  
24 water will be spread at least 48 hours prior to any anticipated  
25 spreading of said water, and give the Department at least 24 hours'  
26 notice of any anticipated change in previously established rates  
27 of spreading. During storm conditions notice will be as is reason-  
28 ably practical under the circumstances.

1 (c) Notify the Department of the time, not less than 24  
2 hours in advance, when it is anticipated that spread water will be  
3 percolated.

4 (d) Keep, maintain and furnish to the Department, records of  
5 estimated quantities of storm water spread by the County at the  
6 Spreading Grounds from all sources. Records to be furnished to  
7 the Department as follows: storm water, monthly; imported and  
8 reclaimed water, daily.

9 To: Department of Water and Power  
10 City of Los Angeles  
11 P. O. Box 111, Room 1420  
12 Los Angeles, California 90051  
13 Telephone: (213) 482-0440

14 (e) Remove or cause to be removed silt which has accumulated  
15 as an incident to spreading of storm water from spreading grounds  
16 upon Department's request.

17 (f) Notify the Department at least 24 hours prior to ini-  
18 tiating maintenance activities.

19 (g) County shall have no claim or right to the water.

20 7. Department will:

21 (a) Maintain all diversion control facilities including the  
22 rubber dam, gates, conduits, and dikes used for the purpose of  
23 controlling the diversion of water to the Spreading Grounds.

24 (b) Notify County 48 hours in advance of the time Department  
25 wishes County to spread Department water.

26 (c) Operate Department's control valves under County direc-  
27 tion when Department has water available for spreading.

28 (d) Maintain and secure all lands, facilities, equipment and

1 improvements at the Spreading Grounds at all times, except County  
2 will be responsible for security during that period commencing  
3 with the initiation of spreading activities and ending when spread  
4 water has percolated. County shall also maintain basin floors as  
5 provided in paragraph 6e.

6 (e) Maintain and repair facilities when necessary in a  
7 prompt and timely manner.

8 8. It is mutually agreed as follows:

9 (a) Preparation of the spreading grounds to conduct the  
10 operations contemplated herein is required. County and Department  
11 shall share the cost equally of all preparations, including  
12 installation of necessary improvements.

13 (b) During periods when the Department has water available  
14 for spreading the Department may require changes or cessation of  
15 storm water delivery rates. Such change or cessation may only be  
16 made upon 48 hours' prior notice to County.

17 (c) The Department reserves the right to direct County to  
18 temporarily cease the spreading of the delivered water at any  
19 time, without prior notice to the County, if, in the opinion of  
20 the Engineer in Charge, Water Operating Division, such action is  
21 required.

22 (d) The Department and the County shall cooperate in the  
23 control of water delivery, transport and spreading so that, to the  
24 extent practical, all water delivered hereunder will be spread  
25 within and upon said Spreading Grounds. That no damages may be  
26 recovered due to a failure to deliver, divert and/or spread water.

27 (e) County shall issue a no fee permit(s) to Department for  
28 requested connections to CONDUIT upon application and subject to

1 the approval of County.

2 9. This Agreement shall be for a term of ten years commencing  
3 upon execution hereof by both parties. In the event that either party,  
4 at the beginning of the ninth year of the term does not give a one-year  
5 notice of termination, this Agreement shall extend for an additional  
6 ten-year term upon the same terms and conditions including renewal  
7 hereof.

8 10. Notwithstanding the provisions of section 9 hereinabove set  
9 forth, either party may terminate this Agreement upon one year's notice  
10 in writing to the other party. In the event the Department terminates  
11 the County's permission to spread water in Tujunga Spreading Grounds  
12 within five years from the date of this agreement, Department shall pay  
13 County any and all costs incurred by the County in fulfillment of this  
14 agreement, including, but not limited to, County's \$200,000 contribu-  
15 tion toward construction costs, any overage the County is obligated to  
16 pay, all costs of preparation of the spreading grounds, any and all  
17 costs of design, engineering and inspection incurred by the County,  
18 including all applicable overhead and/or indirect costs. In the event  
19 the Department terminates the County's permission to spread water in  
20 Tujunga Spreading Grounds within a period of more than five but less  
21 than ten years from the date of this agreement, Department shall pay  
22 County 50% of the costs detailed in the previous sentence.

23 11. The several "notices", if any, that may be required hereunder  
24 shall be given as follows:

25 (a) "Notices" to be given upon 48 hours or less advance time,  
26 shall be given either by actual delivery of written notice or by  
27 telephone message.  
28

1  
2  
3  
4  
5  
6  
7  
8  
9  
10  
11  
12  
13  
14  
15  
16  
17  
18  
19  
20  
21  
22  
23  
24  
25  
26  
27  
28

(i) To: Los Angeles County  
Department of Public Works  
Attention: Operations Chief  
Hydraulic/Water Conservation Division  
Telephone: (818) 458-6309  
Address: 900 South Fremont Avenue, 2nd Floor  
Alhambra, California 91803

(ii) To: Department of Water and Power  
City of Los Angeles  
Attention: Engineer in Charge  
Water Operating Division  
Telephone: (213) 482-0440  
Address: 111 North Hope Street, Room 1420  
Los Angeles, California 90012

(b) Any and all other "Notices", requested hereunder or otherwise given, shall be given by mail as follows:

(i) To: Los Angeles County  
Department of Public Works  
P. O. Box 1460  
Alhambra, CA 91802  
Attention: Division Engineer  
Hydraulic/Water Conservation Division

(ii) To: Department of Water and Power  
City of Los Angeles  
P. O. Box 111, Room 1420  
Los Angeles, California 90051  
Attention: Chief Engineer of Water Works  
and Assistant General Manager

1 INDEMNITY

2 12. County, shall indemnify, defend and hold harmless the  
3 Department, and its officers, employees, agents and representatives,  
4 from and against any and all claims, demands, losses, costs and/or  
5 liabilities which are due to and/or arise from any negligent acts,  
6 errors or omissions of the County, its officers, employees or agents,  
7 occurring in the performance of this Agreement.

8 13. Department shall indemnify, defend, and hold harmless the  
9 County and its officers, employees, agents and representatives from and  
10 against any and all claims, demands, losses, costs and/or liabilities  
11 which are due to or arise from any negligent acts, errors or omissions  
12 of the Department, its officers, employees or agents, occurring in the  
13 performance of this Agreement.

14 ARBITRATION

15 14. Any controversy, claim or dispute arising out of or relating  
16 to this contract, or to a breach or alleged breach thereof which can-  
17 not be informally resolved shall be referred to a board of arbitration,  
18 one member to be appointed by the County and the second member to be  
19 appointed by the Department with the third member to be a disinterested  
20 party appointed by agreement of the other two members. If the two mem-  
21 bers cannot agree on the third member to be appointed, then the third  
22 member shall be appointed by the presiding judge of the Los Angeles  
23 Superior Court. Demand for arbitration may be made by either party or  
24 the other by written notice as provided herein. The notice shall state  
25 the nature of the controversy, claim or dispute. The board of arbitra-  
26 tors shall hold a hearing on the controversy, claim or dispute within a  
27 reasonable time after appointment of all the arbitrators and upon  
28 thirty days' notice to both parties. The board shall consider relevant



1  
2  
3  
4  
5  
6  
7  
8  
9  
10  
11  
12  
13  
14  
15  
16  
17  
18  
19  
20  
21  
22  
23  
24  
25  
26  
27  
28

evidence offered by each party, and may swear witnesses. The decision of the board of arbitrators may be rendered by any two of them. The decision shall be final and conclusive on both parties. Expenses of arbitration, including, without limitation, costs of notices and service thereof, fees of arbitrators and of witnesses (but not of counsel) and the cost of taking and transcribing testimony, shall be shared equally by the parties.

1  
2  
3  
4  
5  
6  
7  
8  
9  
10  
11  
12  
13  
14  
15  
16  
17  
18  
19  
20  
21  
22  
23  
24  
25  
26  
27  
28

IN WITNESS WHEREOF, the parties hereto have caused this Agreement be executed by and through their respective and fully authorized officers on the day and year first above written.



LOS ANGELES COUNTY  
DEPARTMENT OF PUBLIC WORKS

By *Robert E. Schabman*  
Chairman, Board of Supervisors

ATTEST:

LARRY J. MONTEILH  
Executive Officer-Clerk  
of the Board of Supervisors

By *Lurma C. Walton*  
Deputy

DEPARTMENT OF WATER AND POWER OF  
THE CITY OF LOS ANGELES  
BY  
BOARD OF WATER AND POWER COMMISSIONERS OF  
THE CITY OF LOS ANGELES

By *Thomas P. Nichols*  
General Manager and Chief Engineer

and *Judith A. [Signature]*  
Secretary

APPROVED AS TO FORM:

DE WITT W. CLINTON  
County Counsel

By *De Witt W. Clinton*  
Deputy

**ADOPTED**  
BOARD OF SUPERVISORS  
COUNTY OF LOS ANGELES

APPROVED AS TO FORM:

56

MAR 20 1990

JAMES KENNETH HAHN, City Attorney  
EDWARD C. FARRELL, Chief Assistant  
City Attorney for Water and Power

*Larry J. Monteilh*  
LARRY J. MONTEILH  
EXECUTIVE OFFICER

By *Edward C. Farrell*  
Assistant City Attorney

AUTHORIZED BY RES. MAR 08 1990

COOPERATIVE AGREEMENT NO. 47864 BETWEEN  
THE LOS ANGELES COUNTY FLOOD CONTROL DISTRICT AND  
THE LOS ANGELES DEPARTMENT OF WATER AND POWER  
REGARDING ENHANCEMENT DESIGNS FOR THE  
TUJUNGA SPREADING GROUNDS

A G R E E M E N T

This Cooperative Agreement No. 47864 (hereinafter referred to as AGREEMENT) is made and entered into by and between the Los Angeles County Flood Control District (hereinafter referred to as DISTRICT), and the City of Los Angeles Department of Water and Power (hereinafter referred to as LADWP).

W I T N E S S E T H

WHEREAS, the City of Los Angeles (hereinafter referred to as CITY) is home to approximately 4 million residents who depend on reliable sources of water; and

WHEREAS, 85 percent of the water supply of the CITY is imported from sources outside of the region; and

WHEREAS, in addition to imported water, the local water supply is a reliable source of water that depends on groundwater recharged from a variety of sources, including stormwater; and

WHEREAS, local groundwater supply is a key resource that LADWP has historically utilized to support approximately 15 percent of the CITY's total water demand; and

WHEREAS, capturing additional stormwater to augment groundwater recharge is vital to sustain the long-term reliability of the CITY's local groundwater supply; and

WHEREAS, the CITY's water rights in five local groundwater basins are adjudicated, with the San Fernando Groundwater Basin (hereinafter referred to as SAN FERNANDO BASIN) being the largest of the five basins; and

WHEREAS, the CITY possesses the right to the surface waters of the Los Angeles River and the native groundwater of the SAN FERNANDO BASIN in accordance with the California Supreme Court case of *The City of Los Angeles vs. City of San Fernando, et al.*, (1975) 14 Cal.3d 199 and of the Judgment *The City of Los Angeles vs. City of San Fernando, et al.*, Los Angeles Superior Court Case No. 650079, (January 26, 1979); and

WHEREAS, the CITY is a beneficiary of stormwater capture and recharge that may improve the condition of the SAN FERNANDO BASIN and potentially increase the long-term native safe yield to augment the CITY's local water supply; and

WHEREAS, LADWP and the DISTRICT are committed to pursuing opportunities to enhance stormwater capture and groundwater recharge that will increase the long-term native safe yield of groundwater supply in the SAN FERNANDO BASIN; and

WHEREAS, the DISTRICT is a special district organized and operating under the provisions of the Los Angeles County Flood Control Act; and

WHEREAS, pursuant to the Los Angeles County Flood Control Act, the DISTRICT owns and manages flood control and water conservation facilities in the County of Los Angeles (hereinafter referred to as COUNTY), and said efforts result in the capture of stormwater used to replenish groundwater basins in the COUNTY, including the SAN FERNANDO BASIN; and

WHEREAS, the DISTRICT is the regional entity with expertise in design and operation of facilities for stormwater capture and groundwater recharge; and

WHEREAS, the DISTRICT operates five stormwater spreading facilities in the SAN FERNANDO BASIN that recharge local groundwater basins with over 26,000 acre-feet per year for future water supply; and

WHEREAS, LADWP owns and the DISTRICT operates the Tujunga Spreading Grounds to recharge groundwater in the SAN FERNANDO BASIN. The boundaries of the Tujunga Spreading Grounds are defined as shown in Exhibit A, attached; and

WHEREAS, DISTRICT has historically recharged approximately 8,000 acre-feet per year of stormwater at Tujunga Spreading Grounds, which comprises a significant portion of the native safe yield of the SAN FERNANDO BASIN; and

WHEREAS, the DISTRICT and LADWP have recently worked cooperatively to develop conceptual designs for the Tujunga Spreading Grounds Enhancement Project (hereinafter referred to as PROJECT) to upgrade intake facilities and to deepen and reconfigure the recharge basins; and

WHEREAS, when constructed, the PROJECT is conservatively estimated to result in the average annual capture and recharge of an additional 8,000 acre-feet of stormwater into the SAN FERNANDO BASIN that would have otherwise been lost to the ocean; and

WHEREAS, LADWP has requested that the DISTRICT complete a design report, preliminary and final design plans and technical specifications for PROJECT (hereinafter referred to as FINAL DESIGNS) and to provide construction support for the PROJECT, including requests for information, change orders, design changes, and the preparation of final as-built plans (hereinafter referred to as "CONSTRUCTION SUPPORT"); and

WHEREAS, the costs are currently estimated by the DISTRICT as \$1,000,000 total with \$900,000 for the design report and the FINAL DESIGNS and \$100,000 for CONSTRUCTION SUPPORT; and

NOW, THEREFORE, in consideration of the mutual benefits to be derived by the parties, it is hereby agreed as follows:

(1) DISTRICT AGREES:

- a. To complete the design report and the FINAL DESIGNS according to the scope of work presented in "Exhibit B – Tujunga Spreading Grounds Enhancement Project, Final Design Plans and Technical Specifications, Scope of Work" and according to applicable state, federal, and city standards. DISTRICT shall be responsible for quality assurance and quality control for the design report and the FINAL DESIGNS.
- b. To submit invoices to LADWP in the following amounts according to the following schedule;
  1. \$225,000 upon the execution of this AGREEMENT by both parties;
  2. \$225,000 upon submission of the 30 percent design plans, as outlined in Exhibit B;
  3. \$150,000 upon submission of the 60 percent design plans and technical specifications, as outlined in Exhibit B;
  4. \$150,000 upon submission of the 90 percent design plans and technical specifications, as outlined in Exhibit B;
  5. Upon submission of the 100 percent design plans and technical specifications, as outlined in Exhibit B, the DISTRICT shall invoice LADWP for the remainder of the costs accrued in completing the design report and the FINAL DESIGNS, not to exceed a total of \$900,000, along with an accounting of the actual costs.
- c. To complete the design report and the FINAL DESIGNS in accordance with the schedule and conditions specified in Exhibit B.
- d. When LADWP determines to proceed with the construction of PROJECT, and upon written request from LADWP's General Manager or his designee, to provide CONSTRUCTION SUPPORT as described in "Exhibit C – Tujunga Spreading Grounds Enhancement Project, Construction Support and Final As-Built Plans, Scope of Work".
- e. When LADWP makes the written request described in Section 1.d., above, to invoice LADWP for \$50,000 for one-half the estimated costs of CONSTRUCTION SUPPORT (including the completion of the as-built plans). When the expenses incurred by the DISTRICT for work performed in connection with CONSTRUCTION SUPPORT approaches \$50,000,

DISTRICT will notify LADWP, request a second notice to proceed and submit an invoice for the remainder of the costs estimated to be necessary to complete CONSTRUCTION SUPPORT, not to exceed a total of \$100,000. Once construction of the PROJECT is complete, the DISTRICT shall submit to LADWP an accounting of the actual costs of completing CONSTRUCTION SUPPORT along with a reimbursement of any unused funds paid to the DISTRICT pursuant to this paragraph.

- f. To maintain a summary of expenditures for the work for which the DISTRICT is responsible and to make these summaries available to LADWP within 60 days of receiving a written request therefore.
- g. To allow LADWP staff to review the report, designs, and specifications and provide input throughout the development process. LADWP shall have the sole right to make final decisions on all designs in accordance with the Scope of Work in Exhibit B.
- h. If DISTRICT provides CONSTRUCTION SUPPORT, to allow LADWP staff to review responses to requests for information, responses to change order requests, and design changes and to provide input throughout the development process. LADWP shall have the sole right to make final decisions on all requests for information, change orders, design changes, and as-built plan in accordance with the Scope of Work in Exhibit C.
- i. To indemnify, defend, and hold harmless LADWP and the CITY, and their respective officers and employees from and against any claims, demands, liability, damages, costs and expenses, including, without limitation, attorney fees and costs of litigation and claims involving bodily injury, death or personal injury of any person or property damage of any nature whatsoever, arising out of any negligent or reckless act or omission or any willful misconduct of the DISTRICT or its officers, agents, employees, or any of their contractors or subcontractors, in any way relating to the DISTRICT's performance or nonperformance of any obligation of the DISTRICT under this AGREEMENT. This indemnification shall apply except to the extent that the claims, demands, liability or damages arise from the active negligence, recklessness or willful misconduct of LADWP or its officers, employees, agents contractors or subcontractors.

The provisions of this section shall survive expiration or termination of this AGREEMENT.

(2) LADWP AGREES:

- a. To fund 100 percent of the actual costs of the design report and the FINAL DESIGNS and CONSTRUCTION SUPPORT, as outlined above, not to exceed a total contribution of \$1,000,000.

- b. To deposit the amounts specified in the invoices described in paragraphs (1) b. and (1) e., above with DISTRICT within 60 days of receipt of said invoices.
- c. To provide adequate survey and soils data and electronic files in accordance with Exhibit B.
- d. To participate, make decisions, provide technical assistance, and provide directions to DISTRICT in accordance with Exhibit B.
- e. To review and provide comments upon submission of the draft Design Report, Final Design Report, 30 percent plans, 60 percent plans and 90 percent plans and technical specifications in accordance with Exhibit B.

(3) IT IS MUTUALLY UNDERSTOOD AND AGREED THAT:

- a. This AGREEMENT shall be effective on the date it is executed by both LADWP and the DISTRICT and will expire by its own operation six years after execution, or upon the completion of the PROJECT and all tasks associated with this AGREEMENT, unless extended or sooner terminated by mutual written agreement by both LADWP and the DISTRICT. LADWP reserves the right to terminate this AGREEMENT at any time by providing written notice to DISTRICT. If this AGREEMENT is terminated, DISTRICT shall, within 90 days of the termination, provide LADWP with a final accounting of the actual costs incurred in connection with this AGREEMENT prior to the termination and shall return any unused funds previously deposited with the DISTRICT by LADWP. If the DISTRICT's final accounting shows that the actual costs incurred by DISTRICT prior to the termination exceed the amounts previously deposited by LADWP, DISTRICT shall submit a final invoice along with the final accounting and LADWP shall compensate the DISTRICT within 90 days of receipt of final invoice for all costs incurred up to the time of termination, not to exceed a grand total of \$1,000,000. All work described in Exhibits B and C shall be completed by the expiration of this AGREEMENT.
- b. LADWP and the DISTRICT agree to the terms contained in Exhibits B and C.
- c. LADWP and/or the DISTRICT shall have the opportunity to participate and provide input to the work performed by the other party including the development of work plans and the review of draft plans, reports, and studies. However, LADWP shall retain the sole right to make final decisions in a timely manner on all designs for the Tujunga Spreading Grounds in accordance with the scope of work in Exhibit B.

- d. Neither LADWP nor the DISTRICT is obligated to provide additional funds or construct PROJECT.
- e. LADWP has full responsibility for PROJECT, including, but not limited to, preliminary and final design considerations, design of Rubber Dams, general specifications, environmental documentation and permitting, funding, administration, project management, and/or construction.
- f. If it is determined that DISTRICT will not be performing CONSTRUCTION SUPPORT, LADWP may prepare, or cause to be prepared, the final as built plans for the PROJECT.
- g. Both LADWP and the DISTRICT shall be required to make staff reasonably available, if requested, to participate and provide input at scheduled meetings, design workshops, community meetings, construction meetings, construction sites, etc. for the PROJECT in accordance with the scopes of work in Exhibits B and C. Additionally, both LADWP and the DISTRICT shall have the opportunity to participate and provide input at scheduled meetings, design workshops, community meetings, construction meetings, construction sites, etc. for the PROJECT, if desired.
- h. Both LADWP and the DISTRICT shall make all reasonable efforts to keep costs within the budgeted amounts and neither party shall be obligated to provide additional funding toward the completion of work called for by this AGREEMENT, unless otherwise mutually agreed to by the parties.
- i. Both LADWP and the DISTRICT shall make all reasonable efforts to abide by the schedule provided in Exhibit B.
- j. Funds deposited by LADWP shall be utilized toward costs of services rendered for work called for by this AGREEMENT. These services shall include, but are not limited to, direct project administration and all research, planning, design, and engineering associated with the development of plans, designs, and specifications described by this AGREEMENT. Costs of services shall include salary, benefits, indirect/overhead, materials, equipment, services, and any related miscellaneous charges associated with the work called for by this AGREEMENT.
- k. Both LADWP and the DISTRICT shall have no financial obligation to the other party under this AGREEMENT, except as herein expressly provided and in accordance with Exhibits A, B, and C.
- l. This AGREEMENT may be modified only in writing with the signature of both LADWP and the DISTRICT in the manner originally executed.



(4) RIGHT TO AUDIT

The DISTRICT shall maintain all records pertaining to the management of this AGREEMENT in their original form, including but not limited to, reports, documents, deliverables, employee time sheets, accounting procedures and practices, records of financial transactions, and other evidence, regardless of form (e.g., machine readable media such as disk, tape, etc.) or type (e.g., databases, applications software, database management software, utilities, etc.), sufficient to properly reflect all costs claimed to have been incurred and services performed pursuant to this AGREEMENT. All records shall be retained and shall be subject to examination and audit by LADWP personnel or by the LADWP's agents (hereinafter referred to as AUTHORIZED AUDITORS), for a period of not less than three years following final payment made by LADWP hereunder or the expiration date of this AGREEMENT, whichever is later.

The DISTRICT shall make said records or to the extent accepted by the AUTHORIZED AUDITORS, photographs, micro-photographs, etc. or other authentic reproductions thereof, available to the AUTHORIZED AUDITORS at the DISTRICT's offices at all reasonable times and without charge. The AUTHORIZED AUDITORS will have the right to reproduce, photocopy, download, transcribe, and the like any such records. Any information provided by the DISTRICT on machine-readable media shall be provided in a format accessible and readable by the AUTHORIZED AUDITORS. The DISTRICT shall not, however, be required to furnish the AUTHORIZED AUDITORS with commonly available software.

The DISTRICT shall be subject at any time within 60 calendar days, prior written notice to audits or examinations by AUTHORIZED AUDITORS, relating to all billings and to verify compliance with all AGREEMENT requirements relative to practices, methods, procedures, performance, compensation, and documentation.

Examinations and audits will be performed using generally accepted auditing practices and principles and applicable City, State, and Federal government audit standards. For contractors, subcontractors, and suppliers that utilize or are subject to the Federal Acquisition Regulation (FAR), Part 30 and 31, et seq. accounting procedures, or a portion thereof, examinations and audits will utilize such information.

To the extent that the AUTHORIZED AUDITORS' examination or audit reveals inaccurate, incomplete or non-current records, or records are unavailable, the records shall be considered defective.

Consistent with standard auditing procedures, the DISTRICT will be provided 60 calendar days to review the AUTHORIZED AUDITORS' examination results

or audit and respond to LADWP prior to the examination's or audit's finalization and public release.

If the AUTHORIZED AUDITORS' examination or audit indicates the DISTRICT has been overpaid under a previous payment application, the identified overpayment amount shall be paid by the DISTRICT to LADWP within 90 calendar days of notice to the DISTRICT.

If applicable, the DISTRICT shall contractually require all contractors, subcontractors, and suppliers performing services under this AGREEMENT to comply with the provisions of this section by inserting this provision in each contractor contract and by contractually requiring each subcontractor to insert this provision in any of its subcontractor contracts related to services under this AGREEMENT. In addition, the DISTRICT, their contractors, their contractors' subcontractors, and/or suppliers, shall also include the following language in each contract:

"The Los Angeles Department of Water and Power (LADWP) is a third-party beneficiary of the foregoing audit provision. The benefits of the audit provision shall inure solely for the benefit of LADWP. The designation of LADWP as a third-party beneficiary of the audit provision shall not confer any rights or privileges on the DISTRICT, their contractors, and/or their contractors' subcontractors or any other person/entity."

(5) NOTICES

All notices provided under this AGREEMENT must be in writing and, unless otherwise provided herein, shall be deemed validly given on the date either: (1) personally delivered to the address indicated below; or (2) on the third business day following deposit, postage prepaid, using certified mail, return receipt requested, in any U.S. Postal mailbox or at any U.S. Post Office; or (3) on the date of transmission by facsimile to the number provided below. All notices, demands, or requests shall be addressed to the following:

LADWP:                    Director of Water Resources  
                                 Los Angeles Department of Water and Power  
                                 111 North Hope Street, Room 1460  
                                 Los Angeles, CA 90012  
                                 Facsimile: (213) 367-1131

DISTRICT:                Director of Public Works  
                                 County of Los Angeles  
                                 Department of Public Works  
                                 P.O. Box 1460  
                                 Alhambra, CA 91802-1460

(6) COMPLETE AGREEMENT

This AGREEMENT contains the full and complete AGREEMENT between the DISTRICT and LADWP. No verbal agreement or conversation with any officer or employee of either party shall affect or modify any of the terms and conditions of this AGREEMENT.

IN WITNESS WHEREOF, each party hereto has caused this AGREEMENT to be executed by their duly authorized representative.

LOS ANGELES COUNTY  
FLOOD CONTROL DISTRICT,  
a body corporate and political

Date:

7/29/09

By:

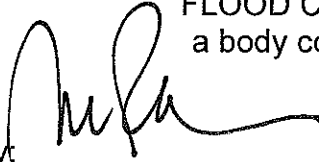

\_\_\_\_\_  
Chief Engineer

APPROVED AS TO FORM:

RAYMOND G. FORTNER, JR.  
County Counsel

By:



\_\_\_\_\_  
Deputy

DEPARTMENT OF WATER AND POWER OF  
THE CITY OF LOS ANGELES BY  
BOARD OF WATER AND POWER COMMISSIONERS  
OF THE CITY OF LOS ANGELES

Date: 7/23/09 By:   
H. DAVID NAHAI  
Chief Executive Officer  
and General Manager

And:   
Secretary

APPROVED AS TO FORM AND LEGALITY  
ROCKARD J. DELGADILLO, CITY ATTORNEY

JUN 11 2009  
BY   
S. DAVID HOTCHKISS  
Assistant City Attorney

AUTHORIZED BY RES. 010-011  
JUL 07 2009

Tujunga Spreading Grounds Design Agreement  
Cooperative Agreement No. 47864  
Exhibit A

Existing Tujunga Spreading Grounds Site Plan

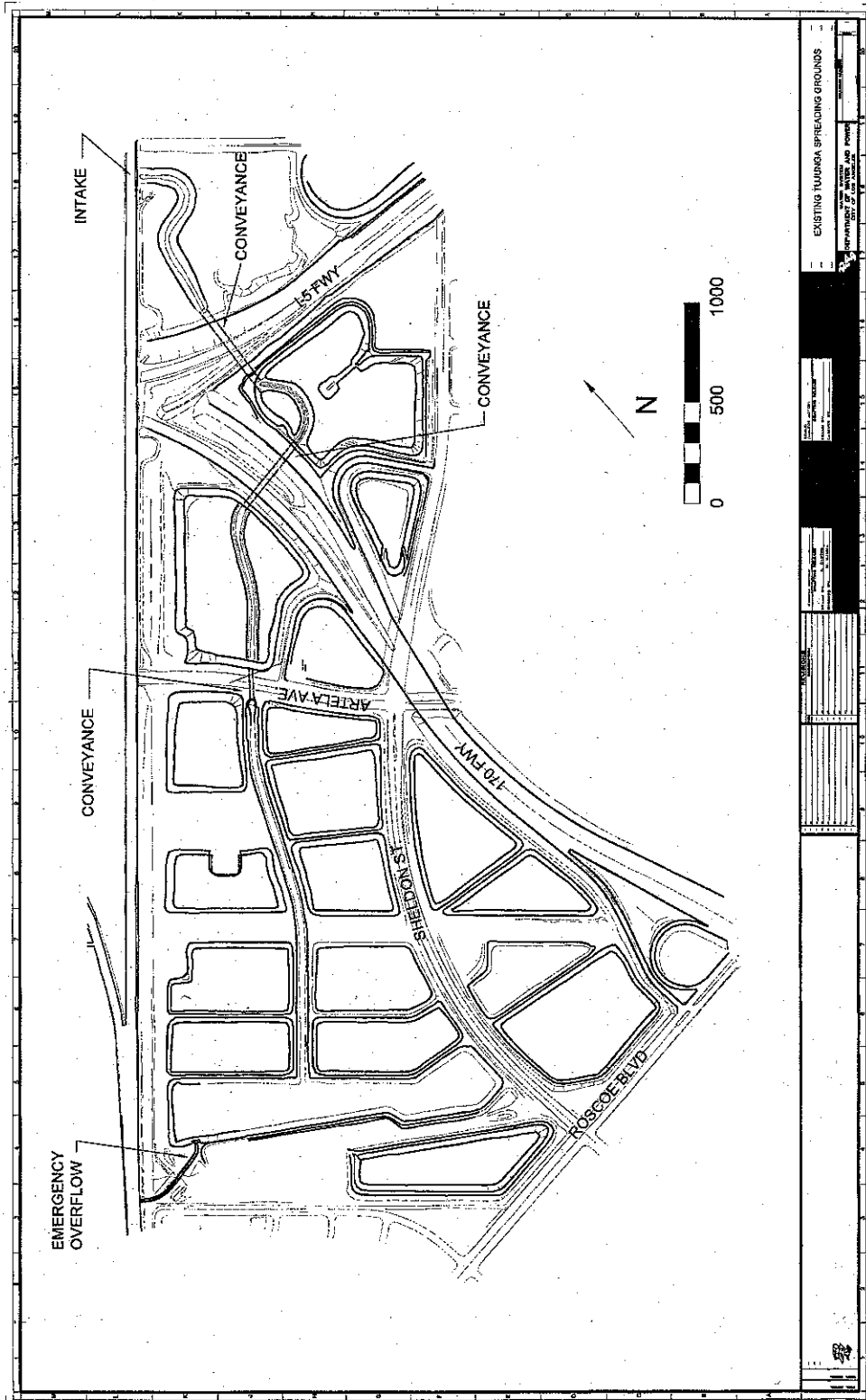

**Tujunga Spreading Grounds Design Agreement  
Cooperative Agreement No. 47864  
Exhibit B**

**Tujunga Spreading Grounds Enhancement Project  
Final Design Plans and Technical Specifications  
Scope of Work**

---

In accordance with Cooperative Agreement No. 47864 (AGREEMENT) between the City of Los Angeles Department of Water and Power (LADWP) and the Los Angeles County Flood Control District (DISTRICT), the DISTRICT will prepare the 100 percent design plans and technical specifications, along with a construction cost estimate (FINAL DESIGNS) for the Tujunga Spreading Grounds Enhancement Project (PROJECT). The FINAL DESIGNS shall be based on the following Project Description, Scope of Work, Deliverables, and Schedule.

Project Description

Currently, Tujunga Spreading Grounds consists of 17 shallow basins, three of which are currently not in use (see Exhibit A - Existing Tujunga Spreading Grounds Site Plan). The maximum intake is 250 cubic feet per second (cfs), the percolation rate is 140 cfs, and the total storage is approximately 100 acre-feet. The water is diverted from Tujunga Wash Channel using a rubber dam and is distributed through the facility using a canal system and flashboard structures.

The PROJECT will consist of the following improvements to the Tujunga Spreading Grounds, as designed, described and shown below:

- Increase the intake capacity by adding an intake downstream of the Interstate 5/Highway 170 interchange
- Increase the storage capacity by combining and deepening basins
- Add an intake facility with the capability to accept flows from both the Pacoima Channel and the Tujunga Wash
- Install new interbasin structures
- Automate the operations
- Retrofit the Tujunga Spreading Grounds' intake lot to treat low flows for recharge in the three basins near the intake
- Reactivate the three basins near the intake
- Prevent the widespread distribution of trash by installing trash booms and/or trash racks.

Tujunga Spreading Grounds Design Agreement  
Cooperative Agreement No. 47864  
Exhibit B

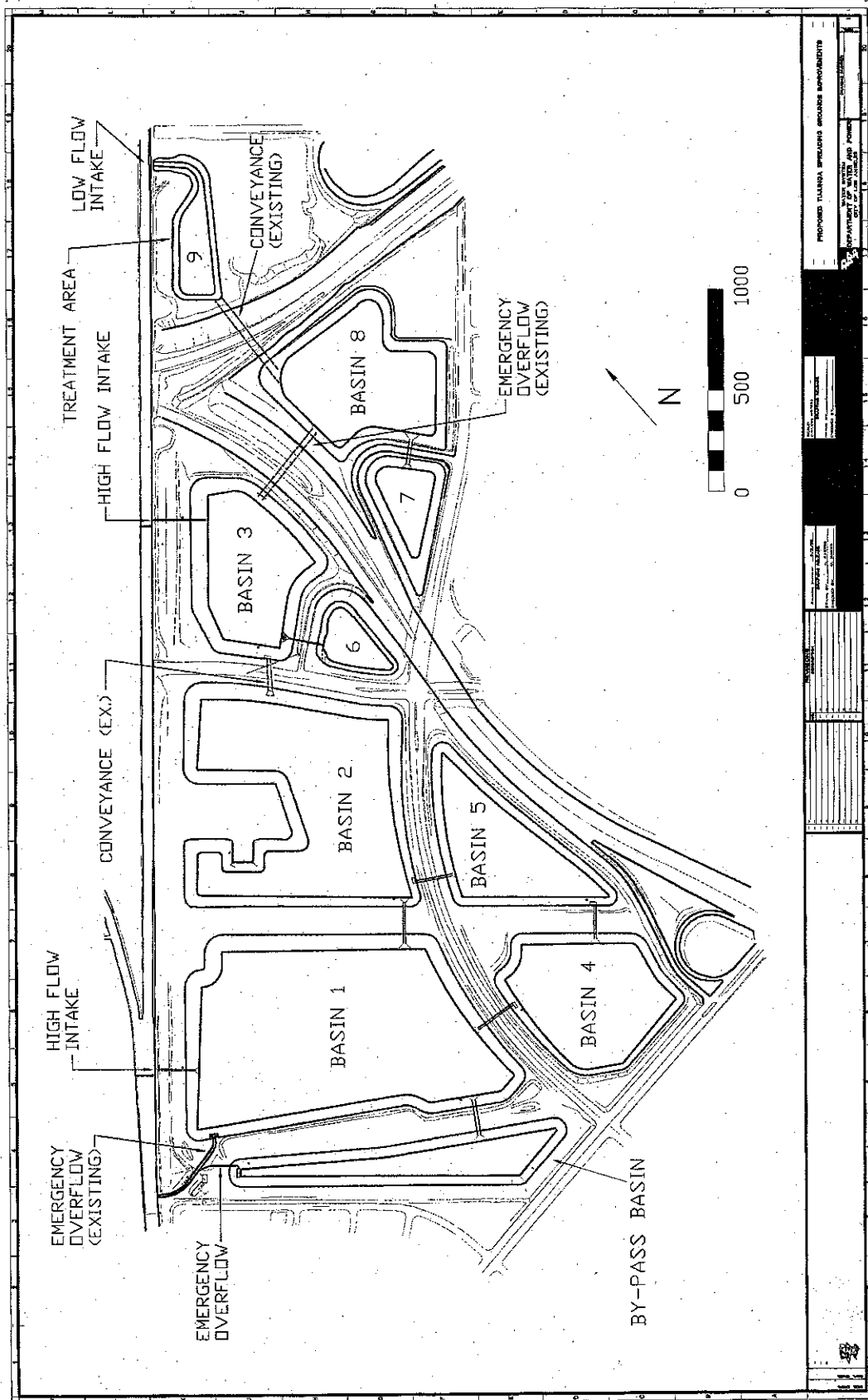



**Tujunga Spreading Grounds Design Agreement  
Cooperative Agreement No. 47864  
Exhibit B**

Scope of Work

1. Topographical soils information and survey data will be provided by LADWP. Survey data shall be in MicroStation XM or V8 format.
  - a. LADWP to provide the DISTRICT with sufficient topographical survey data, soils report and substructure information and maps.
  - b. DISTRICT to verify the data's completeness and accuracy. If data is unacceptable, the DISTRICT shall request assistance from LADWP upon which LADWP will provide necessary information. If LADWP requires more time to provide the additional data, the project schedule shall be extended to include the additional time.
  
2. Design report will be prepared detailing the current and proposed site layout, describing the operations and maintenance for the current and proposed facility, describing the limitations of the current facility, modeling results comparing stormwater capture volumes under current and proposed conditions, estimating cost of the proposed project. Design report shall be submitted to LADWP's Director of Water Resources and shall consist of three hard copies and a CD containing two electronic files, one in Microsoft Word ".doc" format and one in Adobe Acrobat ".pdf" format.
  - a. DISTRICT to submit draft design report to LADWP for review
  - b. LADWP to review and provide comments to DISTRICT
  - c. DISTRICT to revise the draft design report to incorporate LADWP's comments
  - d. DISTRICT to submit final design report to LADWP
  
3. FINAL DESIGNS will be prepared based on the recommendations detailed in the design report. Design plans shall be on LADWP title sheets. Technical specifications shall be according to LADWP standards and shall include construction cost estimates, all bid item quantities, and a detailed submittal log. LADWP will be responsible for general specifications. Design plans and technical specifications shall be submitted to LADWP's Director of Water Resources and shall consist of three hard copies and a CD containing two electronic files, one in Microsoft Word ".doc" or AutoCAD format ".dwg" format and one in Adobe Acrobat ".pdf" format.
  - a. DISTRICT to submit 30 percent design plans to LADWP for review
  - b. LADWP to provide comments on 30 percent design plans
  - c. DISTRICT to incorporate LADWP's comments in design plans
  - d. DISTRICT to submit 60 percent design plans and preliminary technical specifications to LADWP for review and a rubber dam manufacturer to initiate design of Rubber Dam
  - e. LADWP to provide comments on 60 percent design plans and preliminary technical specifications
  - f. LADWP to be the primary contact dealing with a rubber dam manufacturer regarding design of rubber dams

**Tujunga Spreading Grounds Design Agreement**  
**Cooperative Agreement No. 47864**  
**Exhibit B**

- g. DISTRICT to provide assistance to LADWP and rubber dam manufacturer regarding design of rubber dams as needed before submittal of FINAL DESIGNS
- h. DISTRICT to incorporate LADWP's comments in design plans and technical specifications
- i. DISTRICT to submit 90 percent design plans and technical specifications
- j. LADWP to provide comments on 90 percent design plans and technical specifications
- k. DISTRICT to incorporate LADWP's comments in design plans and technical specifications
- l. DISTRICT to submit FINAL DESIGNS to LADWP

**Deliverables**

- 1. Topographical survey data in Microstation XM or V8 format, soils report, and substructures information and maps upon execution of AGREEMENT (to be provided by LADWP)
- 2. Draft design report is due 120 days after receipt of acceptable topographical survey data and soils information
- 3. Comments on draft design report are due 30 days after receipt of draft Design Report
- 4. Final design report is due 30 days after receipt of comments on draft design report
- 5. Thirty percent design plans are due 120 days after receipt of acceptable topographical survey data and soils information
- 6. Comments on 30 percent design plans are due 30 days after receipt of 30 percent design plans
- 7. Sixty percent design plans and preliminary technical specifications are due 120 days after receipt of comments on 30 percent design plans
- 8. Comments on 60 percent design plans and preliminary technical specifications are due 30 days after receipt of 60 percent design plans and preliminary technical specifications
- 9. Ninety percent design plans and technical specifications are due 120 days after receipt of comments on 60 percent design plans and preliminary technical specifications
- 10. Comments on 90 percent design plans and technical specifications are due 30 days after receipt of 90 percent design plans and technical specifications
- 11. FINAL DESIGNS are due 60 days after receipt of comments on 90 percent design plans and technical specifications

Tujungu Spreading Grounds Design Agreement  
 Cooperative Agreement No. 47864  
 Exhibit B

Schedule

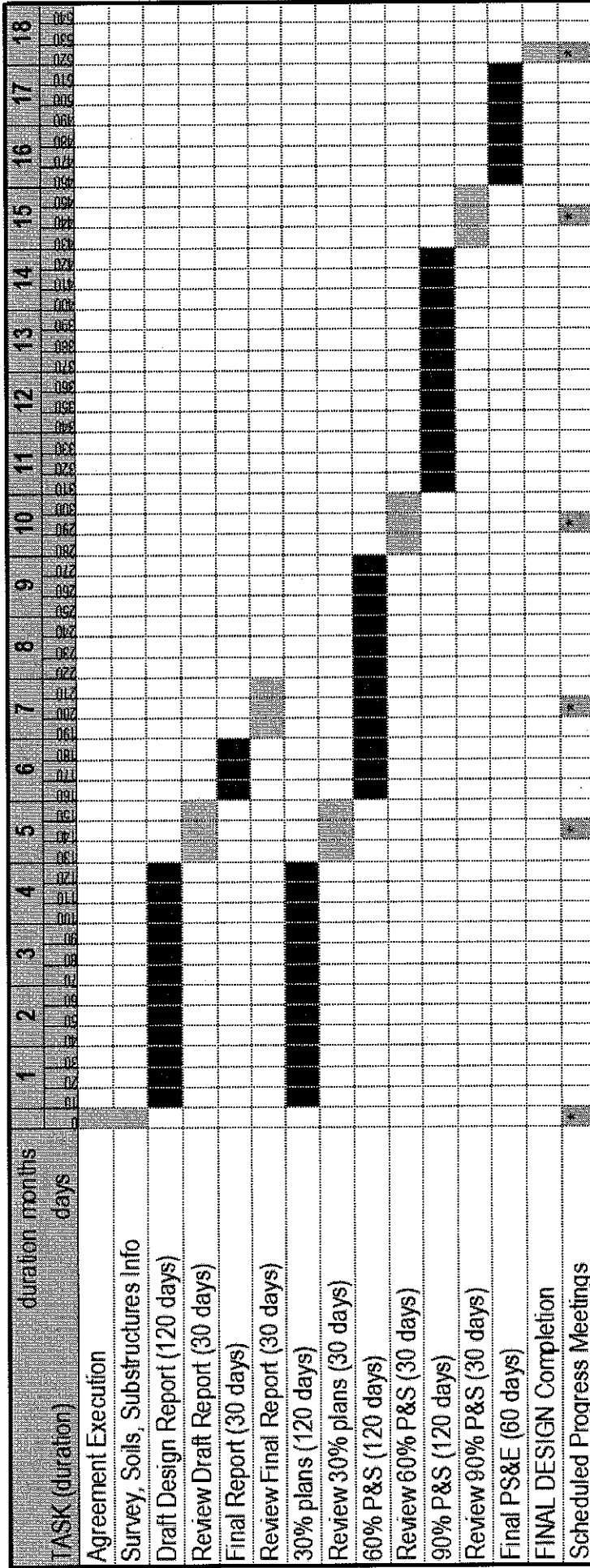

**NOTES:**  
 \* Six scheduled meetings and four upon request. Total not to exceed ten meetings.  
 Working hours are Monday through Thursday from 6:30 a.m. to 5:00 p.m.  
 P&S - Plans and Specifications  
 PS&E - Plans, Specifications and Estimate

**Tujunga Spreading Grounds Design Agreement  
Cooperative Agreement No. 47864  
Exhibit C**

**Tujunga Spreading Grounds Enhancement Project  
Construction Support Including Requests for Information,  
Change Orders, Design Changes, and As-Built Plans  
Scope of Work**

---

In accordance with Cooperative Agreement No. 47864 (AGREEMENT) between the City of Los Angeles Department of Water and Power (LADWP) and the Los Angeles County Flood Control District (DISTRICT), and upon written request from LADWP's General Manager or his designee, during and post-construction, the DISTRICT will respond to requests for information, assist with change orders, provide design and specification changes, and complete as-built plans (CONSTRUCTION SUPPORT) for the Tujunga Spreading Grounds Enhancement Project (PROJECT).

Scope of Work

1. Construction Support
  - a. Requests for Information – The DISTRICT shall respond to requests for information and electronically submit to LADWP's Director of Water Resources
  - b. Change Orders – The DISTRICT shall respond to requests for assistance and electronically submit them to LADWP's Director of Water Resources
  - c. Design and/or Specification Changes – The DISTRICT shall complete design and/or specification changes in an expeditious manner so as not to cause any impact on progress and schedule of PROJECT and submit them to LADWP's Director of Water Resources. Submittals shall consist of three hard copies and a CD containing two electronic files, one in Microsoft Word ".doc" or AutoCAD ".dwg." format and one in Adobe Acrobat ".pdf" format
  - d. As-Built Plans As-Built designs shall be completed and submitted to LADWP's Director of Water Resources. As-Built plans shall adhere to LADWP standards and consist of three hard copies and a CD containing the electronic file in Adobe Acrobat ".pdf" format

Deliverables

1. Responses to requests for Information are due 10 days from the date of the request
2. Responses to change orders are due 10 days from the date of request for assistance
3. Changes to design or specifications are due in an expeditious manner but no more than 30 days from date of request
4. As-Built plans are due 90 days from the date of receipt of notice from LADWP that the PROJECT is complete and complete field notes are submitted to the DISTRICT



ANTONIO R. VILLARAIGOSA  
*Mayor*

Commission  
LEE KANON ALPERT, *President*  
EDITH RAMIREZ, *Vice President*  
FORESCEE HOGAN-ROWLES  
JONATHAN PARFREY  
THOMAS S. SAYLES  
BARBARA E. MOSCHOS, *Secretary*

S. DAVID FREEMAN  
*Interim General Manager*

RAMAN RAJ  
*Chief Operating Officer*

December 28, 2009

Ms. Sarah M. Garber  
MWH Americas, Inc.  
618 Michillinda Avenue  
Arcadia, CA 91007

Dear Ms. Garber:

Subject: Agreement No. 47799  
Authorization to Proceed with Task No. 11  
Tujunga Spreading Grounds Enhancement Project  
Environmental Impact Report (EIR)

Project Description

The Los Angeles Department of Water and Power (LADWP) intends to increase storm water capture by deepening the existing spreading basins, increasing their storage capacity, replacing the existing diversion structure with two diversion structures, and adding remote automation of the operating structures.

The Tujunga Spreading Grounds (TSG) are owned by LADWP and operated by the Los Angeles County Department of Public Works, Flood Control Division. The County diverts stormwater from the Tujunga Wash Channel using a rubber dam and distributes it through the facility. Located at the intersection of the I-5 and 170 freeways, the TSG consist of 17 shallow basins and associated facilities and covers approximately 160 acres.

Scope of Work

MWH Americas, Inc. is hereby authorized, in accordance with Agreement No. 47799, to conduct the following, Task 11, as described in the enclosed MWH Americas, Inc. Proposal, Subject: "Tujunga Spreading Grounds Enhancement Project – Environmental Impact Report" and summarized below.

- Subtask 1 Prepare and Distribute Notice of Preparation (NOP)
- Subtask 2 Conduct Site Investigations and Collect Baseline Data
- Subtask 3 Evaluation of Alternatives
- Subtask 4 Prepare Administrative Draft EIR for Department Review
- Subtask 5 Print and Distribute Draft EIR
- Subtask 6 Response to Comments

**Water and Power Conservation . . . a way of life**

111 North Hope Street, Los Angeles, California 90012-2607 Mailing address: Box 51111, Los Angeles 90051-5700  
Telephone: (213) 367-4211 Cable address: DEWAPOLA

Ms. Sarah M. Garber  
Page 2  
December 28, 2009

Subtask 7      Prepare Final EIR  
Subtask 8      Prepare Mitigation Monitoring and Reporting Program (MMRP)  
Subtask 9      Meetings

Schedule

Start Date:            December 28, 2009  
Completion Date:    March 31, 2011

Budget

The maximum expenditure for this task is \$237,525.

Minority Business Enterprise/Women's Business Enterprise (MBE/WBE) Participation

MWH Americas, Inc. proposes to use BonTerra Consulting and Scientific Resources Associated, two WBE subcontractors, to support the completion of the Task. Their combined fee is \$15,400 which is approximately 7 percent of the total Task budget. MWH Americas, Inc. proposes to use VSA and Associates, a MBE subcontractor, to support the completion of the Task. Their fee is \$14,600 which is approximately 6 percent of the total Task budget. MWH Americas, Inc. proposes to use Fehr and Peers, an OBE subcontractor, to support the completion of the Task. Their fee is \$66,175 which is approximately 28 percent of the total Task budget. The total fee for MBE/WBE labor is \$30,000 which is approximately 13 percent of the total task budget.

Key Task Personnel

Key personnel for this task are:

<u>Name</u>	<u>Organization</u>	<u>Responsibility</u>
Ms. Sarah Garber (626) 568-6910	MWH Americas, Inc.	Consultant Project Manager
Mr. Juan Diaz-Carreras (626) 568-6599	MWH Americas, Inc.	Consultant Task Leader
Mr. Hal Messinger (213) 367-1276	LADWP - Environmental Services (ES)	Task Administrator
Ms. Mary Frances Sandoval (213) 367-4495	LADWP - ES	Contract Administrator

Premises

1. This task shall be performed on a price-and-time basis with a not-to-exceed amount specified in the Budget section of this task.
2. All project-related correspondence associated with this task shall be addressed to:  
  
Mr. Hal Messinger  
Los Angeles Department of Water and Power  
P.O. Box 5111, Room 1050  
Los Angeles, California 90051-5700
3. All invoices and contract administration-related correspondence associated with this task shall be addressed to:  
  
Ms. Mary Frances Sandoval  
Los Angeles Department of Water and Power  
P.O. Box 5111, Room 1050  
Los Angeles, California 90051-5700
4. Invoices for work performed under this task shall be prepared and submitted once a month in accordance with Agreement No. 47799 using Standard Invoice Transmittal Format.
5. The Consultant shall abide by the conditions of Agreement No. 47799 during the performance of this task and shall work according to the Schedule and Budget included herein.
6. The Consultant shall maintain frequent communications with the Task Administrator during the performance of this task. Progress reports shall be prepared and accompany all invoices for Consultant Services.
7. Prior to meeting with or calling governmental agencies or members of the public, the Consultant shall obtain the approval of the Task Administrator. The Consultant shall maintain a log of all conversations and meetings.
8. Requests to amend the scope of work, budget, or schedule for this task should be made in writing to both the contract and task administrators no less than two weeks prior to the task completion date. In addition, all written requests to amend this task shall include a brief justification statement.

Ms. Sarah M. Garber  
Page 4  
December 28, 2009

References

1. Agreement No. 47799 between LADWP and MWH Americas Inc.
2. MWH Americas, Inc. Proposal, Subject: "Tujunga Spreading Grounds Enhancement Project – Environmental Impact Report," dated December 28, 2009.

To facilitate payment of invoices, information identifying the agreement number, task number, task title, task administrator, authorized task budget, invoice total, and remaining task budget, should be included on all invoices. In addition, documentation of all charges, reimbursable expenses, and incidental charges should be included with invoices and clearly delineated or enumerated to readily document expenses.

If you have any questions, please contact Hal Messinger of my staff at (213) 367-1276.

Sincerely,



Mark J. Sedlacek  
Director of Environmental Affairs

Sincerely,



Charles C. Holloway  
Manager of Environmental Planning and  
Assessment

HM:rp  
Enclosure  
c: Mary Frances Sandoval – w/enc.  
Hal Messinger



## **TASK ORDER 011 – TUJUNGA SPREADING GROUNDS ENHANCEMENT PROJECT – ENVIRONMENTAL IMPACT REPORT**

DECEMBER 28, 2009

### **PURPOSE AND OBJECTIVES**

The Tujunga Spreading Grounds (TSG) are owned by the Los Angeles Department of Water and Power (Department, LADWP) and operated by the Los Angeles County Department of Public Works, Flood Control Division. The County diverts stormwater from the Tujunga Wash Channel using a rubber dam and distributes it through the facility. The TSG consist of 17 shallow basins and associated facilities and cover approximately 160 acres. Three of the 17 basins, that cover approximately 8 acres, are presently not in use. The TSG maximum intake is 250 cubic feet per second (cfs) and the percolation rate is 140 cfs. The total storage volume within the TSG basins is approximately 100 acre-ft (32.6 million gallons).

The Tujunga Spreading Grounds Enhancement Project proposes to deepen the existing spreading basins, increase their storage capacity, replace the existing diversion structure with two diversion structures, and add remote automation of the operating structures.

Initial environmental review for this project was conducted under Task Order 1. The purpose of Task Order 11 is to complete California Environmental Quality Act (CEQA) compliance for the project through preparation and processing of an Environmental Impact Report (EIR).

### **PREREQUISITE TASKS**

Completion of TSG Enhancement Project Draft Initial Environmental Study (IES).

### **SCOPE OF WORK TO BE PERFORMED**

The Department will be the lead agency under CEQA for the proposed project. MWH proposes to complete the following tasks to assist LADWP with CEQA compliance for the TSG Enhancement Project.

#### **Task 011.1 Prepare and Distribute Notice of Preparation (NOP)**

MWH will prepare a Notice of Preparation (NOP) of an EIR for the TSG Enhancement Project for distribution to the Office of Planning and Research (OPR), Responsible and Trustee agencies, and known interested parties. The completed IES for the project will be appended to the NOP and up to 50 copies of the document will be printed. Before certified mail distribution by MWH, the Department will review the contents of the NOP and the mailing list for accuracy and completeness. MWH will also prepare a draft Notice of Completion (NOC) to accompany the NOP transmitted to OPR.

## **TASK ORDER 011 – TUJUNGA SPREADING GROUNDS ENHANCEMENT PROJECT – ENVIRONMENTAL IMPACT REPORT**

MWH will summarize comments on the NOP received for review by the Department. As relevant, MWH will assist the Department with contacting (via phone) agencies that comment on the NOP and others that have shown interest in the project to verify their concerns and the scope of work needed to address them.

### **Task 011.2 Conduct Site Investigations and Collect Baseline Data**

As per the results of the Initial Study, the EIR will consist of detailed analysis for air quality, biological resources, traffic, and noise. Reference to the IES will be made for other environmental topics.

After review of existing baseline data and information available from agencies and literature searches, MWH will perform field studies, surveys and analyses as described below.

#### **Biological Resources**

Using the February 2009 report by BonTerra Consulting as a starting point, focused surveys for four special status plant species will be conducted in Basins 6 and 8 to determine the presence or absence of Braunton's milk-vetch (*Astragalus brauntonii*), Nevin's barberry (*Berberis nevinii*), San Fernando Valley spineflower (*Chorizanthe parryi* var. *fernandina*), and slender-horned spineflower (*Dodecahema leptoceras*). These surveys will be conducted during the blooming period for each of the plants, which varies depending on rainfall and temperature. Therefore, reference populations will be monitored to determine the appropriate survey time. Since the blooming periods for these species overlap, one mid-spring survey should cover all four target species. The focused surveys will be conducted using meandering transects throughout the suitable habitat in the two basins. Field notes will be taken during the survey. If any special status plant species are found, the location of each population will be mapped and voucher specimens will be collected and deposited in an appropriate herbarium. A collecting permit is required for the collection of any state-listed endangered species and the team of botanists will have the appropriate permit.

Upon completion of the survey effort, a letter report will be prepared on the survey findings. The letter will include a methods and results section with locations, descriptions of all special status plant species found, and recommended mitigation measures, as relevant. Any special status species observed will be reported to the California Natural Diversity Database.

Additionally, in order to determine permit requirements for the project, informal consultation with the U.S. Army Corps of Engineers, California Department of Fish and Game (CDFG) and the Regional Water Quality Control Board will be conducted to determine if the basins and channels on the sites are considered jurisdictional. Formal wetland delineations are not included in this scope of work.

## **TASK ORDER 011 – TUJUNGA SPREADING GROUNDS ENHANCEMENT PROJECT – ENVIRONMENTAL IMPACT REPORT**

### **Air Quality**

MWH will evaluate construction impacts associated with the diversion structures and recharge basins construction and truck traffic related to soil transport. Construction impacts will be evaluated based on information provided by the Department regarding phasing, construction equipment requirements, truck trips, and workforce requirements. Approaches developed in the SCAQMD CEQA Air Quality Handbook will be used to estimate emissions associated with construction, including heavy equipment emissions and fugitive dust. A screening health risk analysis will be conducted to assess potential risks associated with truck emissions.

MWH will then evaluate emissions based on significance thresholds for the South Coast Air Basin. Where appropriate, MWH will recommend mitigation measures to reduce impacts from construction.

MWH assumes that operational impacts will be minimal, and will be confined to periodic maintenance required for the spreading grounds. Operational impacts will be addressed in a qualitative manner to disclose potential emissions. MWH assumes these emissions will be less than significant.

MWH will include a brief evaluation of impacts to global climate change due to emissions of greenhouse gases from construction and operations. The analysis will be conducted in accordance with the recommendations set forth by OPR, the SCAQMD, and guidance from the California Air Pollution Control Officers' Association (CAPCOA) on inclusion of greenhouse gas evaluations in CEQA documents.

### **Traffic Study**

MWH will prepare an inventory of the existing street system serving the area around Tujunga Spreading Grounds as well as potential construction haul routes to document number of lanes, street widths, traffic control devices, and operational characteristics. Additional pertinent data will also be collected (previously conducted traffic studies and information regarding planned street improvements in the study area).

Traffic conditions at 20 intersections and eight freeway segments in the study area will be evaluated. This includes 12 intersections and four freeway segments near the Tujunga Spreading Grounds and eight intersections and four freeway segments in the area to which the excavated soil will be transported. These study locations will be identified on the basis of anticipated approach/departure routes to/from the sites where project-related trips will be focused. Potential locations include roadways and intersections providing immediate access between the project site and the nearby freeway interchanges, including I-5 and SR-170. For the purpose of this proposal, it is assumed that new traffic count data will be collected at each location. Existing traffic volumes and levels of service at each study location will be quantified based on applicable LADOT standards.

**TASK ORDER 011 – TUJUNGA SPREADING GROUNDS ENHANCEMENT PROJECT –  
ENVIRONMENTAL IMPACT REPORT**

Future traffic volumes (cumulative conditions) will be projected both without and with project related construction traffic. The planned schedule of construction activities within each phase will be reviewed and the peak activity phase will be analyzed for potential temporary traffic impacts.

Estimates of construction-period project employee and truck trip generation will be based on project data provided by the Department and on our experience in analyzing similar projects. To address cumulative impacts, these projections will comprise background traffic growth, cumulative development projects (or related projects) in the study area, and estimates of temporary employee and truck traffic generated by the project. The list of cumulative development projects to be included in this analysis will be identified in conjunction with LADOT and the Los Angeles Community Redevelopment Agency (CRA).

A review of planned access points to the project site will be made and discussions with the project team will be held to confirm the assumptions for the traffic analysis. Potential haul routes will be identified between the Tujunga Spreading Grounds and nearby regional transportation facilities, such as I-5 and SR-170. The haul routes that are the most direct, or otherwise preferable, will be identified and recommendations made. If a potential site for the disposal/storage of soil exported from the site is identified, haul route recommendations will also be made in that area.

An assessment will be made of projected operating conditions, and potential temporary traffic impacts of the proposed project will be identified. Potential adverse project traffic impacts will be assessed in accordance with the LADOT's guidelines. It should be noted that LADOT does not, as a matter of policy, consider temporary construction-related traffic impacts to be significant. Early in the study process, discussions will be held to confirm whether this policy will apply for the assessment of temporary impacts associated with the proposed project.

Appropriate mitigation measures will be developed to alleviate adverse or significant traffic impacts identified. Potential mitigation may be restrictions on the hours and/or routes of construction-period traffic. In the event that physical measures are proposed, they will be examined to determine their physical feasibility and effectiveness, and a recommended plan will be developed. This scope of work includes the identification of recommended haul routes and potential mitigation measures to address temporary impacts that may be identified. It does not, however, include the preparation of detailed geometric design drawings, worksite traffic control plans or other documents or analyses that may be necessary to implement the identified mitigation measures. Any unavoidable adverse or significant construction-period impacts will be identified.

## **TASK ORDER 011 – TUJUNGA SPREADING GROUNDS ENHANCEMENT PROJECT – ENVIRONMENTAL IMPACT REPORT**

The traffic study will entail a quantitative analysis of the construction impacts of the proposed project and one project alternative (in addition to the No Project alternative, which is the scenario against which potential project impacts will be assessed).

### **Noise**

In order to address noise generated by the proposed project, existing information including the local general plan and/or noise ordinance, or applicable standards of other agencies as they relate to noise and vibration will be reviewed. Noise/vibration levels at the project site will be measured to define existing conditions at three locations. At one of the three locations, the noise measurements will be over a 24-hour period (minimum) and at the other two locations the noise measurements will be over a 20-minute period on two separate days. Anticipated noise levels during construction will be calculated based on assumed phasing of construction equipment and vehicles. If predicted impacts exceed established standards for adjacent land uses, mitigation measures will be identified.

In addition, MWH will determine if there is any increase in the noise from traffic associated with the project through prediction of noise levels from traffic associated with the project activities based on assumptions provided by the Department. If predicted impacts exceed established standards for adjacent land uses, mitigation measures will be identified.

### **Task 011.3 Evaluation of Alternatives**

MWH will present the impacts of up to two action alternatives defined by the Department, plus No Project, as required by CEQA. As noted above, it is assumed that only one of the action alternatives will trigger detailed traffic evaluation. Reasons for selection of the preferred project will be presented and an environmentally superior alternative will be identified.

### **Task 011.4 Prepare Administrative Draft EIR for Department Review**

MWH will prepare an Administrative Draft EIR for the Department's review and revise the document based on comments received; two review iterations are anticipated. The Administrative Draft will provide the Department an opportunity to comment on the impact analysis, the significance criteria, description of alternatives to the proposed project and reasons for their rejection, the description of the intended uses of the EIR, all tables and graphics to be presented and to ensure that the document has been prepared in compliance with applicable regulations and guidelines.

### **Task 011.5 Print and Distribute DEIR**

Up to 50 copies of the DEIR will be printed (or CDs will be made) for distribution by MWH. The report will have a 45-day public review, as required by CEQA. The MWH team envisions

## **TASK ORDER 011 – TUJUNGA SPREADING GROUNDS ENHANCEMENT PROJECT – ENVIRONMENTAL IMPACT REPORT**

using the mailing list developed for the NOP, but will amend the mailing list as directed by the Department.

MWH will also assist the Department in the filing of a Notice of Completion (NOC), by preparing a draft notice for Department signature. MWH will also prepare a draft public Notice of Availability (NOA) of the DEIR for mailing to agencies, organizations, and individuals concerned. It is suggested that the NOA also contain the invitation to the public meeting. It is assumed that the Department will place notices in the appropriate local newspapers.

### **Task 011.6 Response to Comments**

After the review period is complete and all comments received, MWH will catalogue the written comments by topic for review with the Department. MWH will then develop final responses for Department approval. Two review iterations are assumed.

Response to up to 10 comment letters is included in this scope of work.

### **Task 011.7 Prepare Final EIR**

Review comments will be incorporated into the Final EIR, with comments on the Draft EIR and responses in a single section in the Appendix. Up to 50 copies (or CDs) of the Final EIR will then be printed for distribution to all commenters on the Draft EIR, to local libraries and Department offices and to OPR. MWH will assist the Department in the preparation of a Notice of Determination by providing a draft NOD for the Department's filing.

### **Task 011.8 Prepare MMRP**

The MWH team will prepare a Mitigation Monitoring and Reporting Program (MMRP) for Department review and adoption at the time the Final EIR is certified.

### **Task 011.9 Meetings**

MWH staff will attend up to five coordination meetings at Department offices and/or the project site.

**TASK ORDER 011 – TUJUNGA SPREADING GROUNDS ENHANCEMENT PROJECT –  
ENVIRONMENTAL IMPACT REPORT**

**PREMISES**

The following assumptions, conditions, and/or restrictions apply to Task Order 011:

1. LADWP will arrange for site access for the project team.
2. LADWP will provide existing information in its files on the construction and operation of Tujunga Spreading Grounds.
3. LADWP will provide a list of known relevant projects for analysis of cumulative impacts.
4. MWH will contact regulatory and responsible agencies only with the prior permission of LADWP.
5. Wetland and vegetation delineations, if determined to be required for project permitting, are not included in this scope of work.
6. LADWP will publish required CEQA notices.
7. No public meetings are planned for the project.
8. LADWP will prepare Findings of Fact for the project.
9. Legal review of the EIR, if any, will be conducted by LADWP.
10. It is assumed there will be no increase in traffic upon completion of the project and no qualitative analysis of the operational traffic impact of the project is included in this scope of work.

**REFERENCES**

England & Nelson. 1976. Significant Ecological Areas. SEA 46 Tujunga Spreading Grounds. Prepared for the County of Los Angeles Department of Regional Planning.

LADWP. 2005. Memorandum of Agreement Between the City of Los Angeles Department of Water and Power and the City of Los Angeles Department of Public Works for the Installation of Gas Collection System at the Sheldon/Arleta Landfill.

-----, 2008. Tujunga Spreading Grounds Project Summary.

-----, 2008. Securing L.A.'s Water Supply. City of Los Angeles Water Supply Action Plan.

Los Angeles County Department of Public Works. 2008. Final Initial Study/Mitigated Negative Declaration, Hansen Spreading Grounds Basin Improvements Project.

**TASK ORDER 011 – TUJUNGA SPREADING GROUNDS ENHANCEMENT PROJECT – ENVIRONMENTAL IMPACT REPORT**

**KEY TASK PERSONNEL**

The following key personnel are assigned to work on Task Order No. 011:

<b>Position</b>	<b>Name</b>	<b>Company</b>
Project Manager	Sarah Garber	MWH
Task Leader	Juan Diaz-Carreras	MWH
Technical Reviewer	Janet Fahey	MWH
Air Quality	Valorie Thompson	Scientific Resources Associated
Biologist	Marc Blain	BonTerra Consulting
Noise	Elyse Friedman Caiello	VSN n Associates
Transportation	Brian Welch	Fehr & Peers
Professional (GIS)	Jackie Silber	MWH
Subconsultant Administrator	Rene Lucero	MWH

**SCHEDULE**

Project start date: December 28, 2009

Project end date: December 31, 2010

**METHOD OF COMPENSATION**

Compensation for Task Order No. 011 shall be on a time and materials basis. Invoices shall be submitted monthly.

**EXPECTED MAN-HOUR EXPENDITURES**

Estimated man-hour expenditures for Task Order 011 are presented in Attachment 1.

**NOT-TO-EXCEED EXPENDITURE LIMIT**

The estimated budget for this task order is \$237,525.00. Funds for this task are budgeted in Agreement No. 47799.







ANTONIO R. VILLARAIGOSA  
*Mayor*

Commission  
LEE KANON ALPERT, *President*  
THOMAS S. SAYLES, *Vice-President*  
ERIC HOLOMAN  
JONATHAN PARFREY  
BARBARA E. MOSCHOS, *Secretary*

AUSTIN BEUTNER  
*General Manager*  
RAMAN RAJ  
*Chief Operating Officer*

August 30, 2010

Ms. Sarah M. Garber  
MWH Americas, Inc.  
618 Michillinda Avenue, Suite 200  
Arcadia, CA 91007

Subject: Task 11, Agreement No. 47799, Amendment 1  
Tujunga Spreading Grounds Enhancement Project  
Environmental Impact Report (EIR)

Dear Ms. Garber:

Task 11 under Agreement No. 47799 was issued on December 28, 2009 to authorize MWH Americas, Inc. (MWH) to prepare an EIR for the Tujunga Spreading Grounds Enhancement Project. To proceed with preparation of the EIR, a determination is needed for the disposal location of excess soil to be generated by project construction. As indicated in your attached letter dated August 30, 2010, MWH would like to request an amendment to Task 11 to conduct research related to locating a soil disposal location. The cost for these additional services is \$25,710 as itemized in your amended Attachment 1.

Your written request, dated August 30, 2010 (enclosed) has been approved. As per your request, the budget has been increased from \$237,525 to \$263,235. All other terms and conditions of this task remain unchanged.

If you have any questions, please contact Mr. Hal Messinger of my staff at (213) 367-1276.

Sincerely,

Mark J. Sedlacek  
Director of Environmental Affairs

Sincerely,

Charles C. Holloway  
Manager of Environmental Planning and  
Assessment Group

HM:aq  
Enclosure  
c/enc: Mr. Hal Messinger

Water and Power Conservation ... a way of life

111 North Hope Street, Los Angeles, California 90012-2607 Mailing address: Box 51111, Los Angeles 90051-5700  
Telephone: (213) 367-4211 Cable address: DEWAPOLA





**MWH**

*BUILDING A BETTER WORLD*

August 30, 2010

Mr. Hal Messinger  
Environmental Services  
Los Angeles Department of Water and Power  
111 North Hope Street, Room 1044  
Los Angeles, CA 90012

Reference: Amendment to MWH Task Order 011 – CEQA Documentation for the Tujunga Spreading Grounds Enhancement Project

Dear Mr. Messinger:

Under Agreement 47799, MWH Americas, Inc. has been assisting LADWP with preparation of a CEQA Initial Environmental Study for the Tujunga Spreading Grounds Enhancement Project. Recently, it was determined that the Department would like assistance in determining a location for disposal of the excess soil to be generated by project construction. MWH would like to request an amendment to Task Order 011 of Agreement 47799, to conduct research related to locating a soil disposal location. Additional work will include:

- Supporting the Department at up to two meetings (one kick-off meeting and one meeting with the owner of a disposal location should a feasible location be identified); up to 25 man-hours (across various disciplines) are assumed.
- Conducting up to 100 man-hours (across various disciplines) of research into potential soil disposal locations.
- Documenting the results of the research in a memo to the Department; up to 25 man-hours (across various disciplines) are assumed.

The cost for these additional services is \$25,710 as itemized in amended Attachment 1. The total not-to-exceed for Task Order 011 would then be \$263,235.

If you have any questions or require any additional information, please do not hesitate to contact Sarah Garber at (626) 568-6910.

Sincerely,

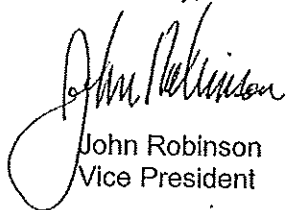
  
John Robinson  
Vice President

  
Sarah Garber  
Principal Environmental Scientist

Enclosure: Attachment 1, Fee Estimate

616 Michilinda Ave.  
Suite 200  
Arcadia, CA 91007

TEL 626 796 9141  
FAX 626 568 6101  
www.mwhglobal.com

**Los Angeles Department of Water and Power**  
**Environmental Assessment and Air Quality Services**  
**Agreement 47799**  
**Task Order 11 - Tujunga Spreading Grounds EIR**  
**Man Hours and Fee Estimate**  
**Amendment 1 - Attachment - 1**

ACTIVITY DESCRIPTION	Contract Hourly Rate										TOTAL HOURS	MWH LABOR FEE	Other Direct Costs (ODCs)	Subconsultants Certification				TOTAL FEE for SUBCONSULTANTS	TOTAL TASK PROPOSAL FEE			
	Principal Professional II	Principal Professional I	Supervising Professional	Senior Professional	Project Professional	Associate Professional	Assistant Professional	Sr. Contracts Administrator	Administrative Assistant	Subconsultants												
										WBE				OBE	MBE	MBE						
	\$205	\$195	\$180	\$160	\$130	\$120	\$100	\$110	\$85				Scientific Resources Associated	Peer and Peers	VSA and Associates							
<b>011</b> Tujunga Spreading Grounds EIR																						
011.1 Prepare and distribute NOP		4	12	16							12	44	\$6,520	\$1,500								
011.2 Site Investigations		8	40	40							16	104	\$16,920									
011.3 Evaluate Alternatives		12	24	80								116	\$19,460									
011.4 Prepare A/EIR		16	24	80	100	20						240	\$40,960									
011.5 Print and Distribute EIR			2	16	24						8	74	\$10,030	\$2,500								
011.6 Respond to Comments			4	24	40	20					8	112	\$16,340	\$2,500								
011.7 Prepare Final EIR			4	8	16							28	\$4,780									
011.8 Prepare MWRP			12	32	20						4	64	\$11,300	\$200								
011.9 Meetings			36	20	90						4	150	\$25,480									
011.10 Soil Disposal																						
<b>TOTALS</b>	<b>16</b>	<b>118</b>	<b>268</b>	<b>450</b>	<b>40</b>	<b>0</b>	<b>0</b>	<b>0</b>	<b>36</b>	<b>52</b>	<b>980</b>	<b>\$160,110</b>	<b>\$6,950</b>	<b>\$8,680</b>	<b>\$6,720</b>	<b>\$66,175</b>	<b>\$14,600</b>	<b>\$96,175</b>	<b>\$263,235</b>			

Total WBE Participation = 5.9%  
 Total MBE Participation = 5.5%  
 Total OBE Participation = 25.1%  
 Total MWH Participation = 63.5%  
 Total Task Order Fee = \$263,235

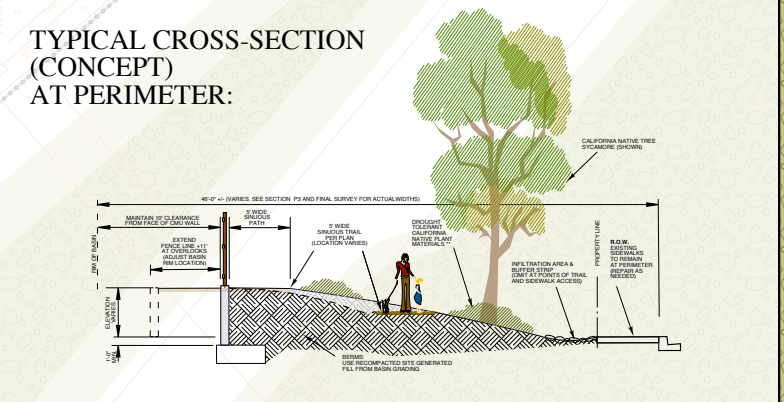

### PHASE I: PHASE I PROJECT OBJECTIVES:

TO MODIFY EXISTING BASIN TOPOGRAPHY TO IMPROVE HYDRAULICS FOR HIGH FLOW (RAINY SEASON) DIVERSIONS FROM TUJUNGA WASH.

TO PROVIDE BASIN ECOLOGICAL AND RECREATIONAL ENHANCEMENTS THAT WILL ALSO ASSIST IN BALANCING SOIL CUT VOLUMES.

TO AVOID AND/OR MITIGATE VECTOR ISSUES

TO PROVIDE SITE AMENITIES THAT WILL AVOID FUTURE USE CONFLICTS WITH UTILITIES AND RESTRICT UNAUTHORIZED PUBLIC ACCESS FROM ESSENTIAL OPERATION AREAS.

### LEGEND:

SYMBOL	DESCRIPTION:
-----	6 -FOOT CHAIN LINK FENCE (W/GATES)
-----	6 -FOOT TUBE STEEL FENCE (W/GATES)
[Green Shaded Area]	LADWP SPREADING BASIN
[Yellow Shaded Area]	LANDSCAPED AREA
[White Shaded Area]	5' PEDESTRIAN PATH/ 17 FT MULTI-USE PATH
[Tree Symbols]	(TREES DEPICTED FOR CONCEPT ONLY-- LOCATIONS & QUANTITIES MAY VARY)

- ### SAMPLE PLANT MATERIALS:
- Manzanita spp.*  
MANZANITA
  - Ceanothus spp.*  
CEANOTHUS
  - Abutilon Palmeri*  
INDIAN MALLOW
  - Heteromeles arbutifolia*  
TOYON
  - Rhus integrifolia*  
LEMONADEBERRY
  - Rhus ovata*  
SUGARBUSH
  - Sambucus mexicana*  
MEXICAN ELDERBERRY
  - Quercus agrifolia*  
COAST LIVE OAK
  - Quercus berberidifolia/dumosa*  
SCRUB OAK
  - Quercus engelmannii*  
MESA OAK

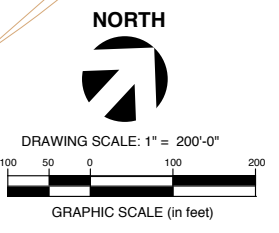

# TUJUNGA SPREADING GROUNDS: PHASE I

LOS ANGELES CITY AND COUNTY OF LOS ANGELES INTEGRATED PARTNERSHIP



DEBORAH DEETS (DRAFT) 9.11.10



**PHASE II:**

**PHASE II PROJECT OBJECTIVES:**

- TO PROVIDE ENHANCED RECHARGE BASINS FOR LOW FLOW (DRY SEASON) DIVERSIONS FROM TUJUNGA WASH.
- TO MODIFY EXISTING BASIN TOPOGRAPHY TO IMPROVE HYDRAULICS AND TO ASSIST IN BALANCING EXPORT FILL.
- TO AVOID AND/OR MITIGATE VECTOR ISSUES
- TO PROVIDE NECESSARY SITE AMENITIES THAT WILL:
- DIRECT PEDESTRIAN AND VEHICULAR CIRCULATION AND MINIMIZE FUTURE USE CONFLICTS WITH MAINTENANCE
- PROVIDE PERIMETER ECOLOGICAL ENHANCEMENTS PROMOTING HEALTHY SOILS BIOLOGY AND VEGETATION.
- TO PROVIDE SIGNAGE OR OTHER MATERIALS THAT EDUCATE THE PUBLIC ON CRITICAL RECHARGE, STORMWATER AND COMMUNITY ISSUES (KIOSK).
- PROVIDE NEW PUBLIC RECREATIONAL SPACE AND USE OPPORTUNITIES.

**LEGEND:**

SYMBOL	DESCRIPTION:
[Line symbol]	6-FOOT CHAIN LINK FENCE (W/GATES)
[Line symbol]	6-FOOT TUBE STEEL FENCE (W/GATES)
[Green fill symbol]	LADWP SPREADING BASIN
[Light green fill symbol]	<b>LOWER TERRACE:</b> SPARSE PLANTINGS OF CA NATIVE DROUGHT AND/OR INUNDATION TOLERANT SPP.
[Yellow-green fill symbol]	<b>WATER-WISE TURF/PICNIC AREA:</b> -UNIFORM SOD w/ SMART IRRIGATION -CALIFORNIA NATIVE DECIDUOUS AND EVERGREEN SHADE TREES
[Light tan fill symbol]	<b>UPPER TERRACE:</b> SCREENING TREES AND SHRUBS VINES ON FENCES AND WALLS GRAVEL
[Blue line symbol]	INFLOWS: -BASIN/ PRIMARY FLOW
[Hatched area symbol]	-INFILTRATION AREAS (HATCHED)
[Orange line symbol]	5' WIDE PEDESTRIAN PATH
[Black line symbol]	17 FT. WIDE MULTI-USE PATH
[Tree symbols]	(TREES & SHRUBS DEPICTED FOR CONCEPT ONLY)
[Landscape symbols]	-LANDSCAPE CONCEPT-- SEE HYDRAULICS AND GRADING PLAN FOR RETAINING WALLS, CONTOURS & ELEVATIONS

**WORKING CONCEPT LAYOUT**  
**10.02.10**

**DESIGNERS GUIDELINES:**

**SUSMP:**  
INFILTRATION BMPs ARE NOT RECOMMENDED FOR AREAS OF INDUSTRIAL ACTIVITY OR AREAS SUBJECT TO HIGH VEHICULAR TRAFFIC (25,000 OR GREATER AVERAGE DAILY TRIPS (ADT) ON ANY INTERSECTING ROADWAY) UNLESS APPROPRIATE PRE-TREATMENT IS PROVIDED TO ENSURE GROUNDWATER IS PROTECTED AND THE BMP IS NOT RENDERED INEFFECTIVE BY OVERLOAD.

SEE: SUSMP GUIDELINES APPENDIX B.12

**Logos:** City of Los Angeles, County of Los Angeles, Los Angeles Department of Water & Power, Sanitation Department of Public Works, Watershed Protection City of Los Angeles.

**Scale:** SCALE: 1" = 0'-0"  
GRAPHIC SCALE (in feet)

**North Arrow:** NORTH

# TUJUNGA SPREADING GROUNDS: PHASE II

LOS ANGELES CITY AND COUNTY OF LOS ANGELES INTEGRATED PARTNERSHIP

**PARKING:**  
66 Standard and + 4 ADA-van accessible stalls  
<45°, one-way, double-loaded  
9'-2" to 9'-4" stalls = 48'-6"

DEBORAH DEETS (DRAFT) 9.11.10

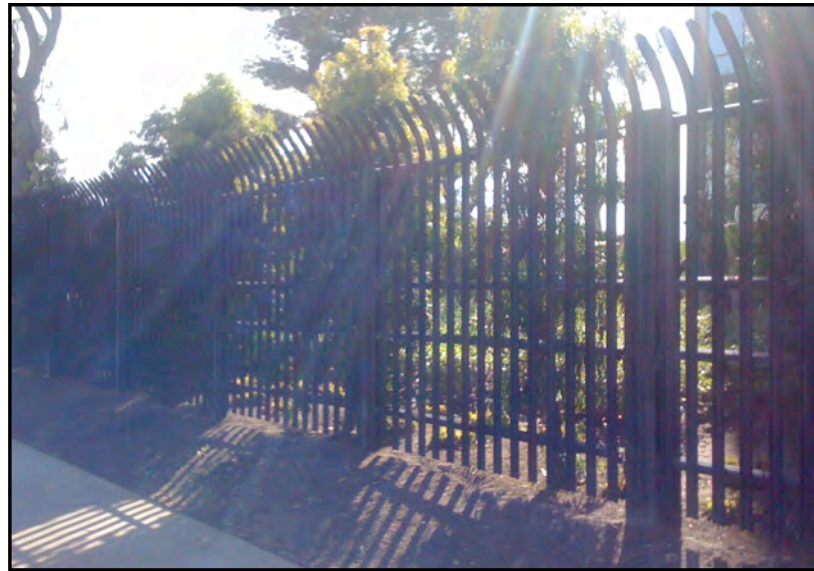

TYPE A



TYPE B (LEFT) / TYPE C (RIGHT)

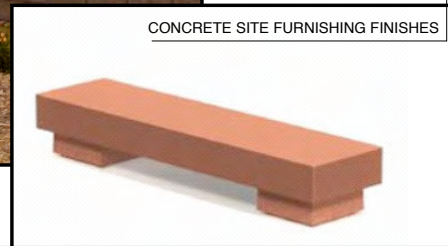
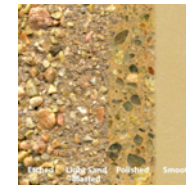

CONCRETE SITE FURNISHING FINISHES



KIOSK

FENCING

CONCRETE SITE FURNISHINGS



OUTDOOR CLASSROOM

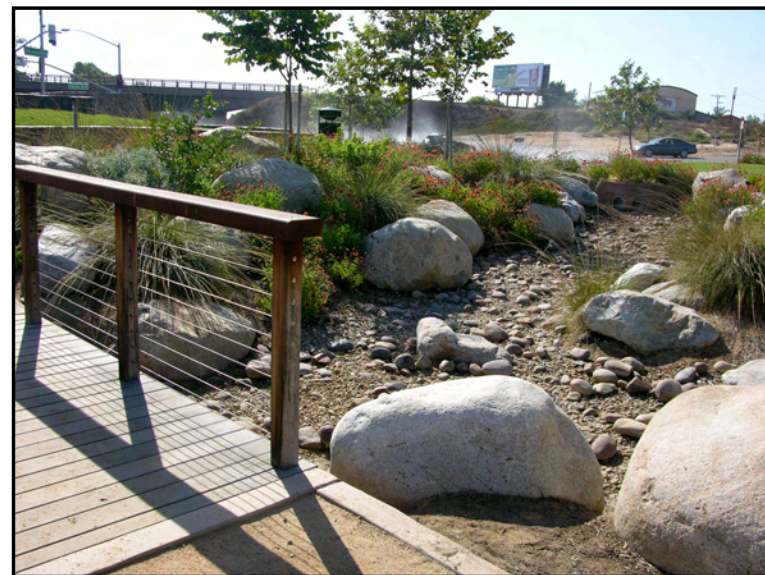

SWALE CROSSING



SWALE AT PAVING



PROPOSED DETAILS--  
FOR DISCUSSION ONLY  
9.11.10.C

TUJUNGA SPREADING GROUNDS: SITE DETAILS

LOS ANGELES CITY AND COUNTY OF LOS ANGELES INTEGRATED PARTNERSHIP

# APPENDIX J

## San Antonio Spreading Grounds Improvements – Three Valleys Municipal Water District



**MEMORANDUM OF AGREEMENT BETWEEN  
THE POMONA VALLEY PROTECTIVE ASSOCIATION  
AND THREE VALLEYS MUNICIPAL WATER DISTRICT  
REGARDING SAN ANTONIO SPREADING GROUNDS  
CONJUNCTIVE USE PROJECT**

THIS AGREEMENT is made, entered into, and executed this \_\_\_\_\_ day of October, 2006, by and between POMONA VALLEY PROTECTIVE ASSOCIATION (PVPA) and THREE VALLEYS MUNICIPAL WATER DISTRICT (TVMWD), collectively or individually respectively hereinafter sometimes referred to as the Parties or Party.

**RECITALS**

- A. PVPA is a California corporation, formed in 1910 by various entities with water interests in the Pomona Valley area generally located in the eastern portion of the County of Los Angeles and the western portion of the County of San Bernardino, engaging in water conservation activities for the benefit of its shareholders, which include the City of Pomona, West End Consolidated Water Company, Golden State Water Company, City of Upland, San Antonio Water Company, and Pomona College.
- B. TVMWD is a Municipal Water District organized and operating pursuant to the Municipal Water District Law of 1911 (*California Water Code* Section 71000 et seq.) and is duly authorized to acquire, control, distribute, store, and spread water for beneficial purposes within its jurisdictional boundaries generally located in the eastern portion of the County of Los Angeles, State of California.
- C. PVPA and TVMWD are parties to a Judgment entered in an action entitled *Southern California Water Company v. City of La Verne et al.*, Los Angeles County Superior Court Case No. KC029152 (the Judgment), which adjudicated the rights to the groundwater in the Canyon Basin, the Upper Claremont Heights Basin, the Lower Claremont Heights Basin, the Live Oak Basin, the Ganesha Basin, and the Pomona Basin (collectively, the Six Basins) and established the Six Basins Watermaster (Watermaster) to administer the Judgment. Among other things, the Judgment prescribes priorities for water Spreading, including as between Replenishment Water and Imported Water, and loss of stored and Carryover Water.
- D. PVPA owns certain real property overlying the Six Basins, including an area of unimproved land known as the San Antonio Spreading Grounds, which is more particularly described as portions of Sections 26 and 35, Township 1 North, Range 8 West, of the Mt. Baldy Quadrangle, and is further depicted in Exhibit "A" attached hereto and incorporated herein by this reference (the Spreading Grounds).

- E. As provided in the Judgment, PVPA and Watermaster have negotiated and executed a “*Memorandum Of Agreement Between The Pomona Valley Protective Association And The Watermaster Of The Six Basins Relating To Groundwater Storage And Related Activities*”, dated January 27, 1999 (the Supplemental MOA) that includes the use of Models for purposes including generating an index water level to monitor groundwater levels, which Models serve as the basis for PVPA’s Spreading Grounds operations.
- F. As authorized by the Judgment, On May 23, 2001, TVMWD and Watermaster executed a Water Storage And Recovery Agreement Between Three Valleys Municipal Water District And Six Basins Watermaster, and Six Basins Watermaster subsequently approved the “*First Amendment To Water Storage And Recovery Agreement Between Three Valleys Municipal Water District And Six Basins Watermaster*”, which authorize spreading up to 1,000 acre-feet per year (collectively, the Storage and Recovery Agreement).
- G. In accordance with the purpose of the Storage and Recovery Agreement, TVMWD wishes to construct and operate a conjunctive use groundwater management project within the Six Basins area as described in the *Final Environmental Impact Report for the San Antonio Spreading Grounds Conjunctive Use Project* dated July 15, 2005, and approved by TVMWD’s Board of Directors on July 27, 2005, with the amount of spreading determined by the Storage and Recovery Agreement (the Project). As proposed, the Project would increase the reliability and reduce the cost of water supply within the Six Basins area by enabling TVMWD to spread surplus Imported Water at the Spreading Grounds for subsequent extraction, including pumping from a groundwater production well to be located on TVMWD’s Miramar Water Treatment Plant property, in a manner consistent with the terms of the Judgment and Watermaster Rules and Regulations.
- H. The purpose of this Agreement is to set forth the terms and conditions under which PVPA will agree to permit TVMWD to use the Spreading Grounds for the construction and operation of the Project.

## COVENANTS

**NOW, THEREFORE**, in consideration of mutual promises, agreements, and covenants herein contained the Parties hereto agree as follows:

### 1. USE OF SPREADING GROUNDS

A. Easement. PVPA hereby grants an easement to TVMWD to use and occupy the portion of the Spreading Grounds identified in the Easement Grant attached hereto as Exhibit “B”, and incorporated herein by this reference, for all purposes necessary to spread

water thereon, to implement the Project, and to use, construct, operate, maintain, repair, and replace the Project facilities and related improvements.

B. Water Spreading and Loss Priority. The priority as between (1) Spreading and Replenishment by PVPA of Replenishment Water, (2) Spreading by TVMWD of Imported Water for the Project, and (3) loss of stored and Carryover Water shall be in accordance with the provisions of the Judgment.

C. Spreading Operations. Subject to the priority established in the Judgment as referenced in Section 1.B. above, Spreading of Imported Water by TVMWD shall be conducted in accordance with the Models referenced in the Supplemental MOA, which Models have been prepared by the engineering firm of Camp Dresser & McKee (the CDM Models). The CDM Models will serve the purpose of coordinating PVPA's and TVMWD's Spreading activities, including but not limited to avoiding high groundwater levels.

D. Coordination. Construction and operation of the Project shall be coordinated with PVPA and any current or future lessee of the Spreading Grounds to accommodate current or potential gravel mining operations or such other projects as PVPA may deem appropriate that are not in conflict with the Project and the rights granted to TVMWD under this Agreement.

E. PVPA Reservation.

- (1) PVPA reserves the right to use the Spreading Grounds for activities

consistent with its spreading activities authorized under the Judgment and Supplemental MOA. PVPA may sell, lease, or otherwise dispose of or encumber the Spreading Grounds in its own discretion to the extent not inconsistent with this Agreement.

- (2) After a period of no less than five (5) years from the Effective Date, PVPA may, in its sole discretion, make available for the Project other areas of the Spreading Grounds (the Project Relocation) in lieu of the area of the Spreading Grounds described or depicted in Exhibit "B" attached hereto, in which event TVMWD shall quitclaim to PVPA the easement provided for herein upon PVPA granting to TVMWD a new easement for the Project Relocation that is in recordable form and that contains terms and conditions that are consistent with the provisions of this Agreement. In order to exercise such option, PVPA shall provide a minimum of two (2) years advance written notice to TVMWD, and PVPA shall be responsible for fifty percent (50%) of all costs associated with the Project Relocation, including but not limited to costs associated with the environmental review, engineering, design, permitting, and construction thereof, but excluding operating and maintenance costs. Additionally, upon delivery of such written notice, the Parties shall meet and confer in good faith with respect to the timing of the Project Relocation (the physical completion of which shall not occur any later than three (3) years from the notice unless otherwise extended by mutual written agreement), the location of the new Project site, cost allocation, and other matters related to the Project Relocation. However, in no event shall the Project Relocation preclude continued operation of the Project or be exercised by PVPA

in such a manner as to require that TVMWD accept any of the following: (a) more than one (1) Project Relocation; or (b) rights relating to the new Project site that are more restrictive in nature, scope, or conditions than the terms of this Agreement or the Easement Grant attached hereto as Exhibit "B"; or (c) obligations relating to the new Project site that are more onerous in nature, scope, or conditions than the terms of this Agreement or the Easement Grant attached hereto as Exhibit "B"; or (d) relocation to a site that would cause an increase in hydraulic gradient for the operation of the Project.

2. ENVIRONMENTAL REVIEW

A. TVMWD Obligations. TVMWD shall be responsible for satisfying all applicable requirements of the California Environmental Quality Act (*Public Resources Code* Section 21000 et seq.), and the Guidelines promulgated thereunder (*California Code of Regulations* Section 15000 et seq.), in approving and implementing the Project.

B. PVPA Obligations. PVPA shall not object, oppose, or challenge, or assist in any objection, opposition, or challenge to, the Project and/or TVMWD's environmental review thereof that may occur from and after the execution of this Agreement.

3. LIABILITY AND INDEMNIFICATION

A. Indemnification.

(1) TVMWD, to the extent which is allowed by law, shall indemnify and hold harmless PVPA, its officers, directors, employees, agents, consultants, and representatives against any and all claims, demands, costs, and/or liabilities due to, or arising from, any act or omission by TVMWD, its officers, directors, employees, or agents in connection with the Project; provided, however, such indemnification obligation shall not extend to any and all claims, demands, costs, and/or liabilities due to, or arising from, matters beyond TVMWD's reasonable control, including, but not limited to, riots, wars, sabotage, civil disturbances, insurrection, explosion, accidents, acts of God, and natural disasters such as floods, drought, earthquakes, landslides, fires, and other catastrophic events.

(2) PVPA, to the extent which is allowed by law, shall indemnify and hold harmless TVMWD, its officers, directors, employees, agents, consultants, and representatives against any and all claims, demands, costs, and/or liabilities due to, or arising from, any act or omission by PVPA and/or its officers, directors, employees, or agents; provided, however, such indemnification obligation shall not extend to any and all claims, demands, costs, and/or liabilities due to, or arising from, matters beyond PVPA's reasonable control, including, but not limited to, riots, wars, sabotage, civil disturbances, insurrection, explosion, accidents, acts of God, and natural disasters such as floods, drought, earthquakes, landslides, fires, and other catastrophic events.

B. General Liability Insurance. TVMWD shall maintain general liability insurance for bodily injury, property damage, personal injury, errors and omissions, and if

practicable, flooding and rising water occurrences. The insurance shall be provided on an as-occurrence basis with PVPA named as an Additional Insured. The initial policy limit shall be at least One Million Dollars (\$1,000,000) and may be increased periodically in accordance with Watermaster directives.

C. High Groundwater Claims or Damages. The Parties agree that any costs associated with defending third-party claims, and/or any resulting damages that may be paid, asserted to be caused directly or indirectly by high groundwater levels in connection with Spreading activities by the Parties, shall not be borne by PVPA so long as PVPA is conducting Spreading in accordance with Watermaster directives as provided in the Judgment.

#### 4. MISCELLANEOUS PROVISIONS

A. Effective Date. This Agreement shall become effective and binding immediately upon its execution by both Parties hereto.

B. Priority of Interpretation. Unless otherwise defined herein, capitalized terms used in this Agreement shall have the same meaning as defined or used in the Judgment or referenced document. In the event of any inconsistency as between this Agreement and the Supplemental MOA, this Agreement shall control, however, PVPA's liability (if any) under this Agreement, including as may arise under Sections 3.A(2) and 3.C., herein, shall be determined and governed by the provisions of the Supplemental MOA and Judgment. In the event of any inconsistency between this Agreement and the Judgment, the Judgment shall control.

C. Written Amendments. This Agreement may only be modified, amended, or supplemented by a subsequent writing executed by each Party hereto.

D. Choice of Law. This Agreement shall be interpreted under the laws of the State of California.

E. Delivery of Notices. All notices permitted or required under this Agreement shall be addressed to the representative of the Parties at the following address, or such other address as the representative of the Parties may provide in writing for this purpose:

PVPA:            President  
                    Pomona Valley Protective Association  
                    414 Yale Avenue, Suite H  
                    Claremont, California 91711

TVMWD:        General Manager  
                    Three Valleys Municipal Water District  
                    1021 Miramar Avenue  
                    Claremont, California 91711

10/12/06

Such notices shall be deemed made when personally delivered or, when mailed, forty-eight (48) hours after deposit in the U.S. Mail, first class postage prepaid and addressed to the Party at its applicable address.

F. Successors and Assigns. This Agreement is binding on and shall inure to the benefit of the Parties and their respective successors in interest and assigns.

G. Assignment. No Party shall have the right to assign its rights or delegate any of its obligations hereunder without the express written consent of the other Party.

H. Construction. Each Party hereto and/or its respective counsel has taken part in the negotiation, drafting, and preparation of this Agreement, and, therefore, any ambiguity or uncertainty in this Agreement shall not be construed against any Party. To ensure that this Agreement is not construed against any Party, the Parties hereto expressly agree that any common law or statutory provision providing that an ambiguous or uncertain term will be construed against the drafter of an agreement is waived and shall not apply to the construction of this Agreement.

I. Integration. This Agreement embodies the entire and final understanding of the Parties hereto pertaining to the subject matter of this Agreement, and supersedes all prior understandings, negotiations, representations, and discussions pertaining to the subject matter hereof, whether verbal or written, of said Parties. The Parties hereto acknowledge that there are no representations, promises, warranties, conditions, or obligations of any Party, or counsel, pertaining to that subject matter other than those contained in this Agreement, and that no Party has executed this Agreement in reliance on any representation, promise, warranty, condition, or obligation, other than those contained in this Agreement.

J. Execution. The Parties to this Agreement acknowledge that they have executed this Agreement voluntarily and without any duress or undue influence. The Parties hereto further acknowledge that they (1) have been represented by counsel of their own choice in connection with the negotiation and execution of this Agreement, or have been advised to seek independent counsel of their own choice prior to executing this Agreement; (2) have read this Agreement in its entirety; and (3) have entered into this Agreement of their own volition and not as a result of any representations or advice by other Party or counsel for any other Party.

K. Counterparts. This Agreement may be executed in one or more counterparts, each of which shall be deemed an original, all of which together shall constitute one and the same instrument.

L. Termination. This Agreement shall be terminated in the event the Project is disapproved or otherwise suspended by TVMWD or by mutual written consent of the Parties.

10/12/06

**DATED:** \_\_\_\_\_

**Pomona Valley Protective Association**

**By:** \_\_\_\_\_

**William M. McDonald  
President**

**DATED:** \_\_\_\_\_

**Three Valleys Municipal Water District**

**By:** \_\_\_\_\_

**Bob G. Kuhn  
President**

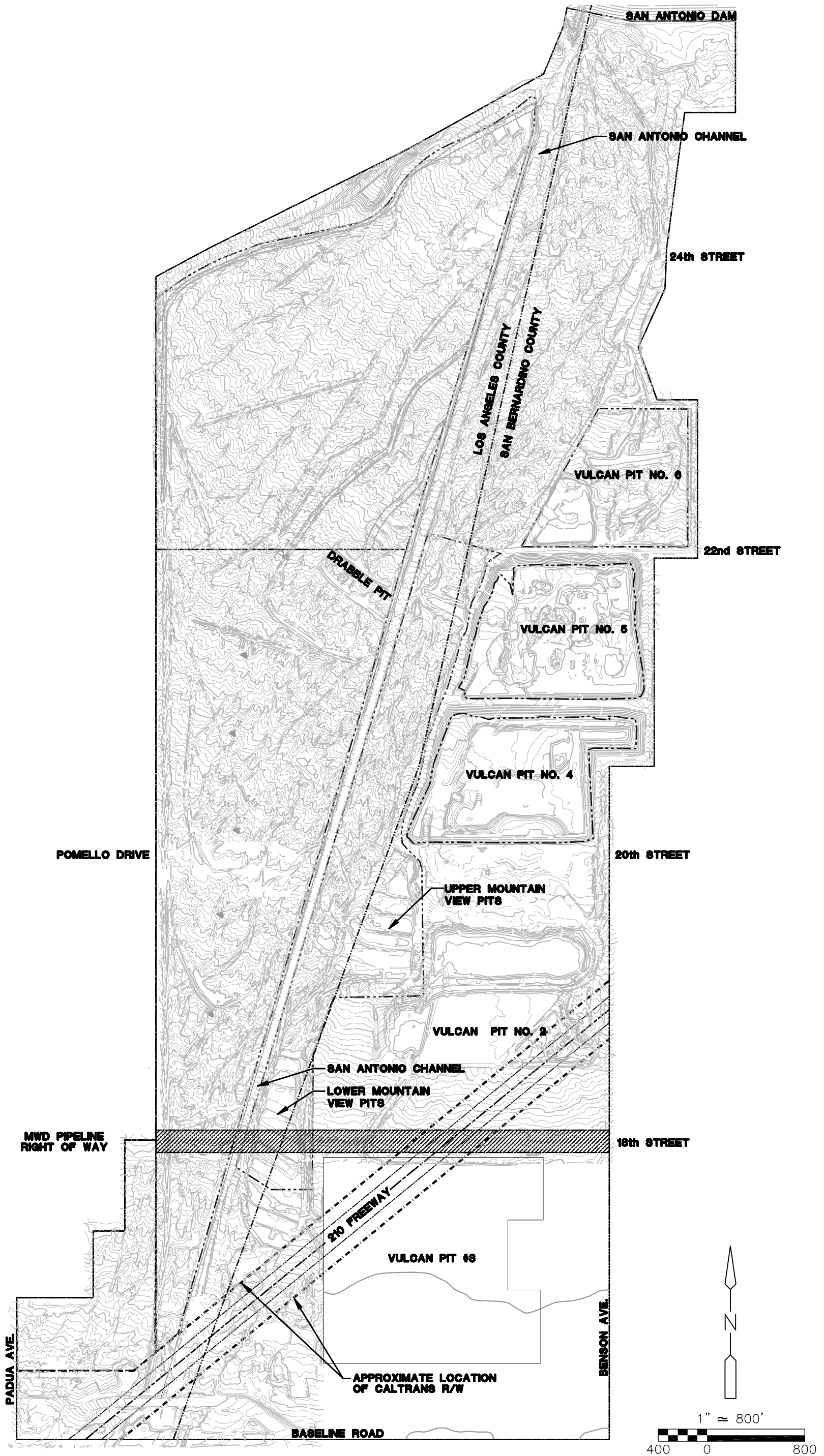



RECORDED AT THE REQUEST OF: )  
Three Valleys Municipal Water )  
District )  
 )  
WHEN RECORDED, MAIL TO: )  
Three Valleys Municipal Water )  
District )  
1021 E. Miramar Avenue )  
Claremont, CA 91711 )  
Attn: Mike Sovich )  
 )

---

Document Transfer Tax \$ None  
(Exempt - Chapter 1108 Statute 1969)

**THREE VALLEYS MUNICIPAL WATER DISTRICT  
EASEMENT GRANT**

BY THIS INDENTURE, made by POMONA VALLEY PROTECTIVE ASSOCIATION, a California corporation (hereinafter referred to as the "Grantor"), for good and valuable consideration, the receipt and sufficiency of which is hereby acknowledged, Grantor does hereby grant, bargain, sell, and convey unto the THREE VALLEYS MUNICIPAL WATER DISTRICT, a public agency (hereinafter referred to as the "Grantee"), its successors and assigns, a perpetual easement hereinafter described, to construct, reconstruct, remove, replace, repair, maintain, operate, and use two pipelines and up to seven turnout water distribution structures, together with braces, connections, fastenings, cables, and other appliances, equipment, fixtures, and improvements in connection therewith or appurtenant thereto, for the transmission, distribution, and spreading of water on, under, along, and across that certain real property located in the County of San Bernardino, State of California, as described in Exhibit "1" and shown on Exhibit "2" attached hereto and by this reference incorporated herein.

This grant shall carry with it the right to inspect, make vehicular patrols, and alter the said pipelines, structures, fixtures, improvements, and other appurtenances, the right to mark the location of said easement by suitable markers set and maintained in the ground at locations which shall not interfere with such reasonable use as the Grantor shall make of the land within the limits of said easement, from the said easement across the lands of the Grantor, for all purposes useful or convenient in connection with or incidental to the exercise and enjoyment of the rights herein granted.

Any and all such pipelines, structures, and other appurtenances shall at all times remain the property of Grantee notwithstanding the same may be annexed or affixed to the freehold, and shall at any time and from time to time be removable, in whole

or in part, by Grantee, its successors and assigns.

Grantor reserves the right to full use and enjoyment of said premises, except for the purposes herein granted, provided that such use and enjoyment shall not hinder, conflict, or interfere with the exercise of Grantee's rights hereunder, and that no excavation, building, structure, or obstructions shall be constructed on the said easement without Grantee's written consent, which consent shall not be unreasonably withheld. Grantor shall be solely responsible for the payment of any and all costs associated with the replacement or restoration of any excavation, building, pipeline, structure, appurtenance, or obstruction that is damaged or destroyed as a result of Grantee's reasonable exercise of the rights granted herein.

Grantor represents, covenants, and warrants that the undersigned which is/are shown on record in said County as owners in fee simple of the lands hereinabove described are indeed the owners of such fee simple title, subject only to outstanding encumbrances, if any, now on record in said County.

The provisions hereof shall inure to the benefit of, and be binding upon, the parties hereto and their respective heirs, representative, executors, administrators, successors, and assigns.

IN WITNESS WHEREOF, these presents are hereby signed this day of \_\_\_\_\_, 2006.

GRANTOR:

---

GRANTOR:

---

(Attach Notary Certificate)

## **EXHIBIT 1**

Three Valleys Municipal Water District is planning to construct pipelines and spread imported water on a portion of the San Antonio Spreading Grounds (SASG) owned by the Pomona Valley Protective Association (PVPA) shown as the red-line boundary on Exhibit 2 below. This approximately 144 acre portion of the SASG is located within the City of Claremont in Los Angeles County and the City of Upland in San Bernardino County, Sections 26 and 35 of Township 1 North, Range 8 West, of the USGS Mt. Baldy Quadrangle. The boundaries are described generally as parallel to and 200 feet north and 100 feet east of the Lower Mountain View pits in San Bernardino County; along the west side of the San Antonio Creek channel in Los Angeles County; approximately 700 feet north and parallel to the westward extension of Pomello Drive in Claremont; south to State Highway 210 along PVPA's western boundary in Los Angeles County; and northeast to the Lower Mountain View Pits coincident with the northern edge of easement for State Highway 210.

EXHIBIT 2

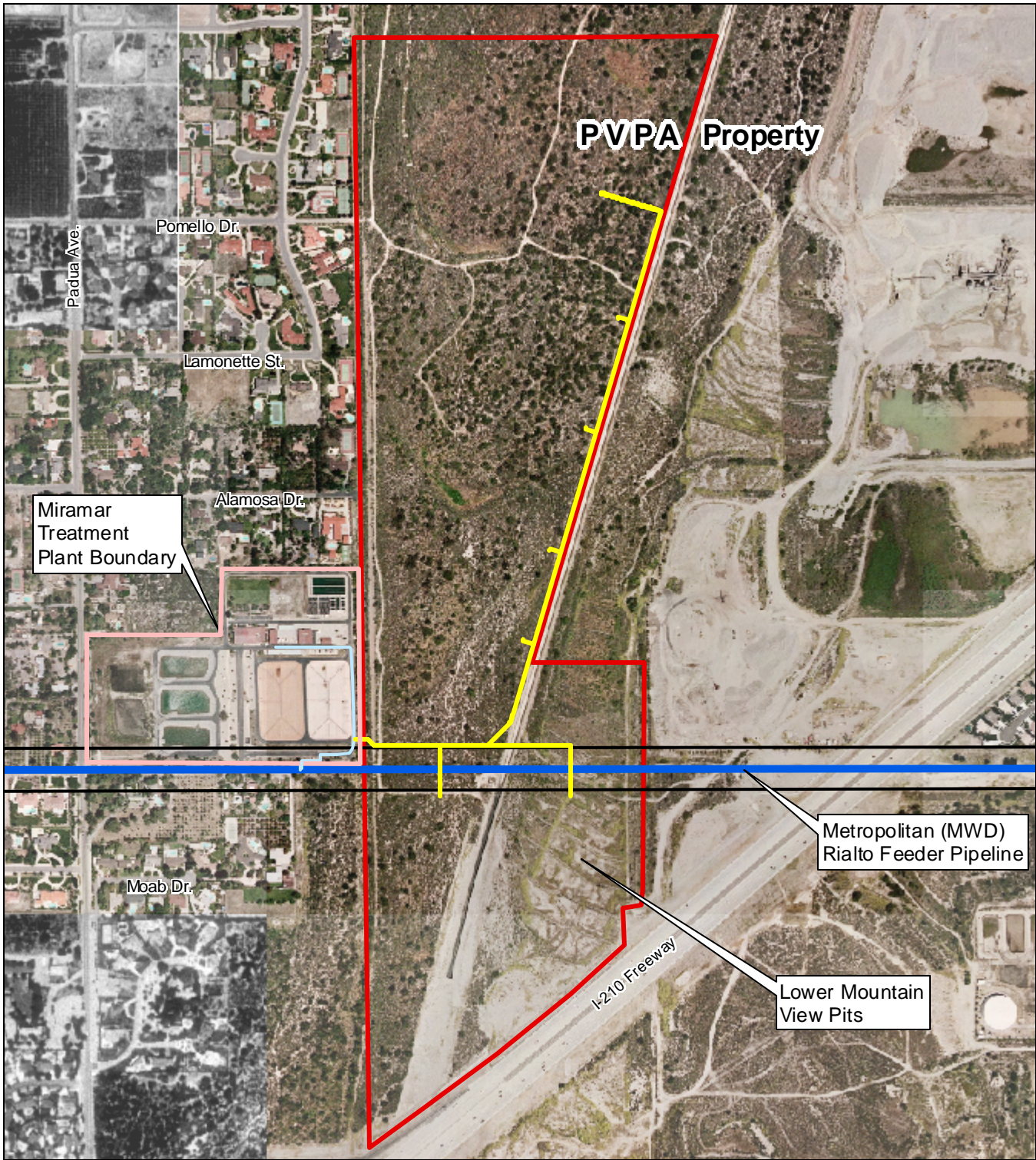

P:\11001.000.0\gis\esri\proposed\_pipeline4.mxd

**Explanation**

- Easement Boundary per Exhibit 1
- Existing Pipeline (MWD)
- Proposed Pipeline
- Miramar Treatment Plant Influent Pipeline
- MWD Pipeline Right of Way (200 Feet Wide)



700 350 0 700

APPROXIMATE SCALE IN FEET

Basemap modified from color aerials (2004) USGS DOQQs, Mt Baldy SW (1996) and Ontario NW (1998)

**TVMWD EASEMENT EXHIBIT 2**  
 Three Valleys Municipal Water District  
 San Antonio Spreading Grounds  
 Conjunctive Use Project  
 Los Angeles and San Bernardino Counties, California

By: mww Date: 9/28/2006 Project No. 11001



Figure **2**

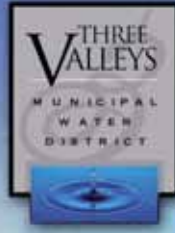

# Feasibility Study for the Multi-Agency Regional Groundwater Recovery Project



In cooperation with the Azusa Light and Water, the City of Glendora, Rowland Water District, Three Valleys Municipal Water District, and the Walnut Valley Water District

February 2010





# **FEASIBILITY STUDY FOR THE MULTI-AGENCY REGIONAL GROUNDWATER RECOVERY PROJECT**

100% Draft - February 2010

IN COOPERATION WITH THE

**MULTI-AGENCY PARTNERSHIP**

**AZUSA LIGHT AND WATER**

**CITY OF GLENDORA**

**ROWLAND WATER DISTRICT**

**THREE VALLEYS MUNICIPAL WATER DISTRICT**

**WALNUT VALLEY WATER DISTRICT**

*Prepared by:*



**General Civil, Municipal, Water and Wastewater Engineering,  
Planning, Construction Management and Surveying**

Monrovia Prescott Phoenix



# **FEASIBILITY STUDY FOR THE MULTI-AGENCY REGIONAL GROUNDWATER RECOVERY PROJECT**

100% Draft - February 2010

Under the Supervision of:

\_\_\_\_\_  
W. David Byrum, P.E.

43296

R.C.E.



**FEASIBILITY STUDY FOR THE MULTI-AGENCY REGIONAL GROUNDWATER RECOVERY  
PROJECT-100% DRAFT**

**Executive Summary**

Water is a valuable resource that is locally produced for the benefit of drinking water, irrigation, and industrial processes. Maintaining autonomy through the use of local sources and facilities improves reliability, relieves stress upon import sources and collectively meets the objectives of an integrated effort to support demands within the San Gabriel Valley and Southern California as a whole. To facilitate the production of such sources, multi-agency partnerships of local municipalities and water districts have joined forces. This partnership is comprised of Azusa Light and Water, the City of Glendora, Rowland Water District, Three Valleys Water District and Walnut Valley Water District. Each participant provides a unique contribution to the integrated effort in formulating a plan that will further utilize and promote the use of local ground water sources.

Water quality within the main San Gabriel Basin has for years been impacted by the influence of contaminants on this precious local source and has caused or limited the production of ground water from 7 wells in the basin. For this reason the partnership plans to combine their collective resources to treat water produced from these wells for the beneficial use of their respective service areas.

Ground water has been successfully treated for many years within the basin for such beneficial uses. As a result the partnership is looking for ways to preserve and extend existing groundwater sources to their customers and control increasing costs and have prepared this Feasibility Study.

Participant customers average daily demand is projected to be over 82 million gallons of water per day (MGD), 92,093 acre-feet annually under build-out conditions. For perspective, an acre-foot of water is about 326,000 gallons, which could serve the needs of two typical families for one year. Water use by participant customers is projected to increase gradually over this period. Azusa Light and Water and the City of Glendora rely greatly on local groundwater and surface water production sources to meet customer demand and seek to limit reliance on Metropolitan Water District (MWD) water as much as practical. Rowland Water District and Walnut Valley Water District are heavily dependent on MWD and seek to reduce large portion of this reliance by utilizing local ground water sources. Over time, as the demand for potable water increases regionally, more costly water sources will be require, and imported water rates paid by project participants will certainly increase. The use of the available potable water supplies may also be limited during drought.

Project participants can reduce their reliance on imported water purchases by decreasing the total potable water demand through conservation and use of local ground water resources. The resulting benefits of using local groundwater supplies include:





**FEASIBILITY STUDY FOR THE MULTI-AGENCY REGIONAL GROUNDWATER RECOVERY  
PROJECT-100% DRAFT**

- Reducing the total cost of imported water purchases
- Cleaning up local ground water sources
- Improving the imported water supply reliability for the region

In addition to the use of local ground water, public education and water conservation measures, can help project participants meet their customer water demands in a cost-effective way.

A number of market ready treatment alternatives were reviewed for applicability of use as solutions for producing the contaminated ground water. Each technology was evaluated based on the treatment effectiveness, capital cost, operations and maintenance cost, regulatory acceptance, waste generation and treatment foot print. Each of the wells are generally impacted by VOCs (in particular TCE and DCE), perchlorate, and nitrates. A blend of treatment solutions suitable for each constituent was selected to provide the final product. VOC treatment will be performed through liquid phase granular activated carbon. Perchlorate removal will be addressed through treatment in a Fixed-Bed Single pass ion exchange system utilizing perchlorate selective resin. Finally nitrate treatment will utilize regenerable ion exchange resin with nitrate selectivity. The capacity of the treatment system has been sized to accommodate 15,000 gpm which equates to 24,200 acre-ft per year or 26 percent of project participant’s projected average day demand.

Estimated capital costs for the recommended system are around 66 million dollars. Operations and maintenance costs for the project are estimated at 8 million dollars per year. Amortizing the capital costs over the useful life (30 years) of the treatment components, and adding the annual O&M costs, the resulting unit cost of producing 24,200 acre feet of water is nearly \$490 per acre-ft. Cost comparisons with other facilities treating water in the basin are relatively similar. Securing grant and other low-cost funding sources will further offset the cost impact and reduce the initial and continuing cost of operating the treatment system.

A preliminary financial analysis for the system has been created to identify available funding sources that should be pursued to support project objectives. Ultimately, considering the cost of replenishment water will be integral in establishing project viability in comparison with continued use of MWD water. Currently replenishment water is available for use at a cost of \$526 per acre-ft. Adding this to the cost of producing the water is \$1,016 per acre-foot. Tier 1 MWD water is \$701 per acre-ft, but is anticipated to increase to over \$1,000 per acre-ft in the near future.

Due to the overall negative impact of doing nothing and continue the strain on import water supplies while MWD costs progressively increase it is recommended to pursue project implementation through preliminary design and evaluation.





**FEASIBILITY STUDY FOR THE MULTI-AGENCY REGIONAL GROUNDWATER RECOVERY  
PROJECT-100% DRAFT**

Chapter 1 - Introduction ..... 1-1

    1.1 General Description..... 1-1

    1.2 Study Area ..... 1-3

    1.3 Scope of Report ..... 1-5

    1.4 Abbreviations ..... 1-7

    1.5 Acknowledgments..... 1-8

Chapter 2 – Water Quality..... 2-1

    2.1 Overview ..... 2-1

    2.2 Description of Wells ..... 2-4

    2.3 Occurrence of Contaminants ..... 2-6

    2.4 Contaminant Regulation ..... 2-9

    2.5 Discussion of Regulatory Environment ..... 2-10

    2.6 Water Quality Goals..... 2-15

Chapter 3 – Properties, Sources and Health Risks of Contaminants..... 3-1

    3.1 Chemical Properties ..... 3-1

    3.2 Probable Sources..... 3-2

    3.3 Health Risks..... 3-3

Chapter 4 – Treatment Processes ..... 4-1

    4.1 Treatment Overview ..... 4-1

    4.2 Particulate Removal ..... 4-2

    4.3 VOC Removal ..... 4-4

    4.4 Perchlorate Removal ..... 4-6

    4.5 Nitrate Removal..... 4-8

    4.6 Removal of Multiple Contaminants..... 4-8

    4.7 Comparisons between Treatment Systems ..... 4-10

    4.8 Waste Discharge Requirements..... 4-15

    4.9 Site Considerations..... 4-16

        4.9.1: Site 1 ..... 4-18

        4.9.2: Site 2 ..... 4-19

        4.9.3: Site 3 ..... 4-20

        4.9.4: Site 4 ..... 4-22





**FEASIBILITY STUDY FOR THE MULTI-AGENCY REGIONAL GROUNDWATER RECOVERY  
PROJECT-100% DRAFT**

4.9.5: Site 5 ..... 4-23

4.9.6: Site 6 ..... 4-25

4.9.7: Site 7 ..... 4-26

4.9.8: Site 8 ..... 4-27

4.9.9: Site 9 ..... 4-28

4.9.10: Site 10 ..... 4-30

Chapter 5 – Treatment Systems Case Studies ..... 5-1

5.1 General Description..... 5-1

5.2 Case Studies..... 5-1

5.3 Treatment Equipment Installed at Local Utilities ..... 5-4

Chapter 6 – Blending Analysis..... 6-1

6.1 General Overview ..... 6-1

6.2 Blending Description..... 6-1

6.3 Blending Analysis Assumptions ..... 6-2

Chapter 7 – Hydraulic Analysis ..... 7-1

7.1 General ..... 7-1

7.2 Demand..... 7-1

7.2.1: ALW Demand..... 7-1

7.2.2: Glendora Demand..... 7-4

7.2.3: WVWD Demand ..... 7-6

7.2.4: RWD Demand ..... 7-7

7.2.5: Demand Summary ..... 7-8

7.3 Sources ..... 7-11

7.3.1: Aspan..... 7-12

7.3.2: Vosburg (Glendora Well 7)..... 7-12

7.3.3: Azusa 9 ..... 7-12

7.3.4: Azusa 10 ..... 7-12

7.3.5: Contract ..... 7-13

7.3.6: Glendora 3..... 7-13

7.3.7: Glendora 4..... 7-13

7.4: Methods of Rehabilitation..... 7-13





**FEASIBILITY STUDY FOR THE MULTI-AGENCY REGIONAL GROUNDWATER RECOVERY  
PROJECT-100% DRAFT**

7.5: Existing Infrastructure..... 7-13

7.6: Design Criteria and Hydraulic Assumptions ..... 7-14

7.7 Collection System ..... 7-16

    7.7.1: Pipelines ..... 7-16

    7.7.2: Well Pumps..... 7-16

    7.7.3: Treatment Facility ..... 7-19

    7.7.4: Equalization Tank..... 7-19

7.8 Distribution System..... 7-20

    7.8.1: Connection Points ..... 7-20

    7.8.2: Pipelines ..... 7-22

    7.8.3: Booster Station..... 7-29

7.9 Summary..... 7-31

Chapter 8 – Preliminary Site Layouts and Cost Estimates ..... 8-1

    8.1 General Overview..... 8-1

    8.2 Appurtenant Equipment Requirements..... 8-1

    8.3 Preliminary Site Layouts ..... 8-7

    8.4 Treatment Equipment Cost Estimates ..... 8-11

    8.5 Analysis of Cost per Agency..... 8-14

Chapter 9 – Project Implementation Schedule And Permitting..... 9-1

    9.1 General Overview..... 9-1

    9.2 Preliminary Project Schedule..... 9-3

    9.3 Preliminary Permits ..... 9-4

Chapter 10 – Recommendations And Next Steps ..... 10-1

    10.1 Recommendations ..... 10-1

    10.2 Coordinating the Missions of the Interested Parties ..... 10-1

    10.3 Financing..... 10-4

        10.3.1: Pay-As-You-Go..... 10-4

        10.3.2: Pay-As-You-Use ..... 10-4

        10.3.3: State Revolving Fund (DWSRF)..... 10-5

        10.3.4: DWR Water Bond 2000 – Proposition 13 ..... 10-5

        10.3.5: Metropolitan Water District ..... 10-5





TABLE OF CONTENTS

FEASIBILITY STUDY FOR THE MULTI-AGENCY REGIONAL GROUNDWATER RECOVERY PROJECT-100% DRAFT

10.3.6: Revenue Bonds (1911 and 1915 Acts)..... 10-6

10.3.7: State Grants - Proposition 84 and Proposition 1E ..... 10-7

10.3.8: Certificates of Participation ..... 10-8

10.3.9: Water Quality Authority ..... 10-9

10.3.10 Funding Recommendation ..... 10-15



**FEASIBILITY STUDY FOR THE MULTI-AGENCY REGIONAL GROUNDWATER RECOVERY  
PROJECT-100% DRAFT**

# Figures

Figure 1-1: Study Area (Excerpts from the 2009 USGS Baldwin Park and San Dimas  
Quadrangles) ..... 1-4

Figure 2-1: Well Locations within Baldwin Park Operable Unit (Excerpt from WQA §406  
Plan) ..... 2-2

Figure 2-2: Well Locations in Relation To San Gabriel Basin Contamination Plume  
(Excerpt From WQA §406 Plan)..... 2-7

Figure 4-1: Cartridge Filter ..... 4-2

Figure 4-2: Multi-Cartridge Filter Vessel ..... 4-2

Figure 4-3: Bag Filters ..... 4-3

Figure 4-4: Bag Filter Vessel..... 4-3

Figure 4-5: Example of Activated Carbon..... 4-4

Figure 4-6: Example of GAC Vessels ..... 4-5

Figure 4-7: Air Stripping Packs..... 4-5

Figure 4-8: Air Stripping Towers..... 4-5

Figure 4-9: Example of Ion Exchange Resin..... 4-7

Figure 4-10: Vessels Utilized in the Perchlorate Ion Exchange Treatment Process..... 4-7

Figure 4-11: Site Considerations ..... 4-17

Figure 4-12: Aerial Photo of Site 1 ..... 4-18

Figure 4-13: Aerial Photo of Site 2 ..... 4-19

Figure 4-14: Aerial Photo of Site 3 ..... 4-21

Figure 4-15: Aerial Photo of Site 4 ..... 4-22

Figure 4-16: Aerial Photo of Site 5 ..... 4-24

Figure 4-17: Aerial Photo of Site 6 ..... 4-25

Figure 4-18: Aerial Photo of Site 7 ..... 4-26

Figure 4-19: Aerial Photo of Site 8 ..... 4-27

Figure 4-20: Aerial Photo of Site 9 ..... 4-29

Figure 4-21: Aerial Photo of Site 10 ..... 4-30

Figure 4-22: Site 10 Little Dalton Wash ..... 4-32

Figure 6-1: Blending Diagram for Perchlorate ..... 6-3

Figure 6-2: Blending Diagram for Nitrate ..... 6-4





TABLE OF CONTENTS

**FEASIBILITY STUDY FOR THE MULTI-AGENCY REGIONAL GROUNDWATER RECOVERY  
PROJECT-100% DRAFT**

Figure 7-1: ALW’s Local Production Redundancy ..... 7-4

Figure 7-2: Glendora’s Local Production Redundancy ..... 7-6

Figure 7-3: Distribution of Water from Treatment Plant ..... 7-9

Figure 7-4: Location of Well Field Within the Main San Gabriel Basin ..... 7-11

Figure 7-5: Hydraulic Model..... 7-15

Figure 7-6: Generic Pump Performance Curve ..... 7-17

Figure 7-7: Groundwater Contour of Well Field..... 7-18

Figure 7-8: Distribution System Pipeline Alignment Evaluation ..... 7-23

Figure 7-9: Preferred System Configuration ..... 7-28

Figure 7-10: VFD Curves for Recommended Booster Pumps ..... 7-30

Figure 8-1: Typical On-Site Chlorine Generation System..... 8-5

Figure 8-2: Preliminary Site Layout ..... 8-8

Figure 8-3: Concept Process Flow Diagram..... 8-10



**FEASIBILITY STUDY FOR THE MULTI-AGENCY REGIONAL GROUNDWATER RECOVERY  
PROJECT-100% DRAFT**

# Tables

Table 2-1: Contaminant Concentration Summary ..... 2-8

Table 4-1: Impact Evaluation for Determining Feasibility of Cartridge Filter Systems . 4-3

Table 4-2: Impact Evaluation for Determining Feasibility of Bag Filter Systems..... 4-4

Table 4-3: Impact Evaluation for Determining Feasibility VOC Removal System ..... 4-6

Table 4-4: Impact Evaluation and Point Value for Determining Feasibility of Perchlorate Ion Exchange Treatment ..... 4-7

Table 4-5: Impact Evaluation and Point Value for Determining Feasibility of Nitrate Ion Exchange Treatment ..... 4-8

Table 4-6: Impact Evaluation and Point Value for Determining Feasibility of Multiple Contaminant Treatment..... 4-10

Table 4-7: Evaluation of Particulate Treatment Process..... 4-11

Table 4-8: Evaluation of VOC Treatment Processes ..... 4-12

Table 4-9: Evaluation of Perchlorate Treatment Processes..... 4-13

Table 4-10: Evaluation of Nitrate Treatment Processes..... 4-14

Table 4-11: Sites Considered As Potential Locations For The Proposed Treatment Plant And Pump Station. .... 4-18

Table 5-1: Summary of Equipment Used in Local Installations..... 5-5

Table 7-1: Current Capacity of ALW’s Groundwater Production..... 7-3

Table 7-2: Current Capacity of Glendora’s Groundwater Production..... 7-5

Table 7-3: Overview of WVWD Supply and Demand ..... 7-7

Table 7-4: Overview of RWD Demand..... 7-7

Table 7-5: Summary of Distribution of Water from Treatment Plant ..... 7-9

Table 7-6: Availability of Basin Water for ALW..... 7-10

Table 7-7: Availability of Basin Water for Glendora..... 7-10

Table 7-8: Raw Water Collection Pipeline Details..... 7-16

Table 7-9: Well Pump Design Details ..... 7-19

Table 7-10: Pavement Type Alignment Parameter ..... 7-24

Table 7-11: Commercial Impact Alignment Parameter..... 7-24

Table 7-12: Street Classification Alignment Parameter ..... 7-25

Table 7-13: Capacity Alignment Parameter ..... 7-25

Table 7-14: Trench Repair Alignment Parameter..... 7-25







TABLE OF CONTENTS

**FEASIBILITY STUDY FOR THE MULTI-AGENCY REGIONAL GROUNDWATER RECOVERY  
PROJECT-100% DRAFT**

Table 7-15: School Impact Alignment Parameter..... 7-26

Table 7-16: Evaluation of East-West Alignment..... 7-26

Table 7-17: Evaluation of North-South Alignment..... 7-27

Table 7-18: Total Length of Pipe Broken Down by Benefitting Stakeholder..... 7-29

Table 7-19: Collection and Distribution System Improvements ..... 7-31

Table 8-1: Summary of Treatment Plant Equipment Requirements ..... 8-6

Table 8-2: Capital Cost Estimate for Construction of Treatment Facility ..... 8-12

Table 8-3: Operations and Maintenance Costs for Treatment Facility ..... 8-13

Table 8-4: Benefits Breakdown for Treatment, Production and Collection..... 8-14

Table 8-5: Benefits Breakdown for Distribution All Participants ..... 8-15

Table 8-6: Benefits Breakdown for Distribution for Glendora, WVWD, and RWD..... 8-15

Table 8-7: Benefits Breakdown for Distribution..... 8-15

Table 9-1: Project Implementation Schedule..... 9-4



**FEASIBILITY STUDY FOR THE MULTI-AGENCY REGIONAL GROUNDWATER RECOVERY  
PROJECT-100% DRAFT**

# Appendices

Appendix A ..... A-1  
Appendix B .....B-1  
Appendix C .....C-1



**FEASIBILITY STUDY FOR THE MULTI-AGENCY REGIONAL GROUNDWATER RECOVERY  
PROJECT-100% DRAFT**

**Chapter 1 - Introduction**

**1.1 General Description**

This study has been prepared to determine the feasibility of developing and improving the availability of local groundwater resources for the benefit of a multi-agency partnership. Due to the scarcity of ground water in the region and the impacts of high cost import water sources, the need for a collective and combined effort has become integral in establishing goals and developing a plan. As a result the formation of this multi-agency partnership; consisting of local cities and water districts, has been created to study the feasibility of constructing a regional groundwater treatment facility that will serve the needs of the Main San Gabriel Groundwater Basin and will deliver these local groundwater supplies to agencies that are greatly impacted by the high cost of import water. The agencies involved include Azusa Light and Water (ALW), the City of Glendora (Glendora), Rowland Water District (RWD) and the Walnut Valley Water District (WVWD). The proposed treatment facility will treat 10,000 to 15,000 gallons per minute (gpm) of poor quality groundwater and deliver it to each of the respective systems. The goals of the project are as follows:

- ◆ Improve availability of ground water to ALW and Glendora during peak demand periods to limit use of import water sources.
- ◆ Improve reliability of ground water for all agencies during all demand scenarios and deliver a good portion of the water to RWD and WVWD.
- ◆ Improve Water Quality within the Main San Gabriel Basin Groundwater Basin (Basin).

ALW's water supply consists of groundwater, local surface water and imported water. ALW currently operates 11 groundwater wells of which two are off-line due to elevated level of contamination. ALW imports water from the Metropolitan Water District of Southern California (MWD) primarily for emergency purposes which accounts for less than one percent of its production. The two wells that are off-line and third well whose production is limited are being considered as sources for this treatment facility. By resuming production from these three wells, ALW will improve capacity, reliability and redundancy of its water supply sources while remaining essentially independent of more costly imported water from MWD.

Glendora's water supply consists of groundwater and imported water. Glendora currently operates 11 groundwater wells of which three are off-line due to high volatile organic compounds (VOC) and nitrate levels. 13.8% of Glendora's water supply is imported water from MWD and 1.6% is delivered from the Covina Irrigating Company as a local surface water source. The three inactive wells are being considered as potential sources for this treatment facility. Restoration of these groundwater sources has the potential to replace all of Glendora's imported water supply.



**FEASIBILITY STUDY FOR THE MULTI-AGENCY REGIONAL GROUNDWATER RECOVERY  
PROJECT-100% DRAFT**

Rowland Water District (RWD) currently receives 100% of its potable water supply from MWD. RWD desires to address its supply reliability by acquiring or developing other sources. In addition, unit costs for imported water from MWD are high (currently \$745 per acre-foot), and these costs will continue to increase due to issues surrounding the availability of surface water to MWD, specifically recent judicial decisions at the federal level and prolonged drought conditions. This project will allow RWD to gain additional sources, thereby reducing its dependence on MWD as a single source and deflecting the costs associated with importing water from MWD.

Walnut Valley Water District (WVWD) is almost entirely dependent on imported potable water purchased from MWD through its member agency, Three Valleys Municipal Water District (TVMWD). Potable quality groundwater is not available within WVWD's service area as the local shallow aquifers (Puente and Spadra Basins) contain high concentrations of total dissolved solids and nitrates. However, the local groundwater is of sufficient quality for non-potable demands and is typically used to augment the recycled water distribution system during the peak summer demand period. Additional makeup water for the recycled water distribution system is supplied from WVWD's potable water system as necessary. This project will provide access to a non-MWD source with the potential of deflect the rising costs of imported surface water and improve water reliability.

The treatment plant will utilize existing well facilities currently owned and operated by ALW and Glendora. Furthermore, although not an agency involved with this study, the Covina Irrigating Company has agreed to allow the use of one of its wells. Production from these seven wells will supply the raw water to the treatment plant:

- ALW
  - Azusa Well Number 9 (Azusa 9)
  - Azusa Well Number 10 (Azusa 10)
  - Aspan Well
- City of Glendora
  - Glendora Well Number 3 (Glendora 3)
  - Glendora Well Number 4 (Glendora 4)
  - Vosberg Well
- Covina Irrigating Company
  - The Contract Well



**FEASIBILITY STUDY FOR THE MULTI-AGENCY REGIONAL GROUNDWATER RECOVERY  
PROJECT-100% DRAFT**

**1.2 Study Area**



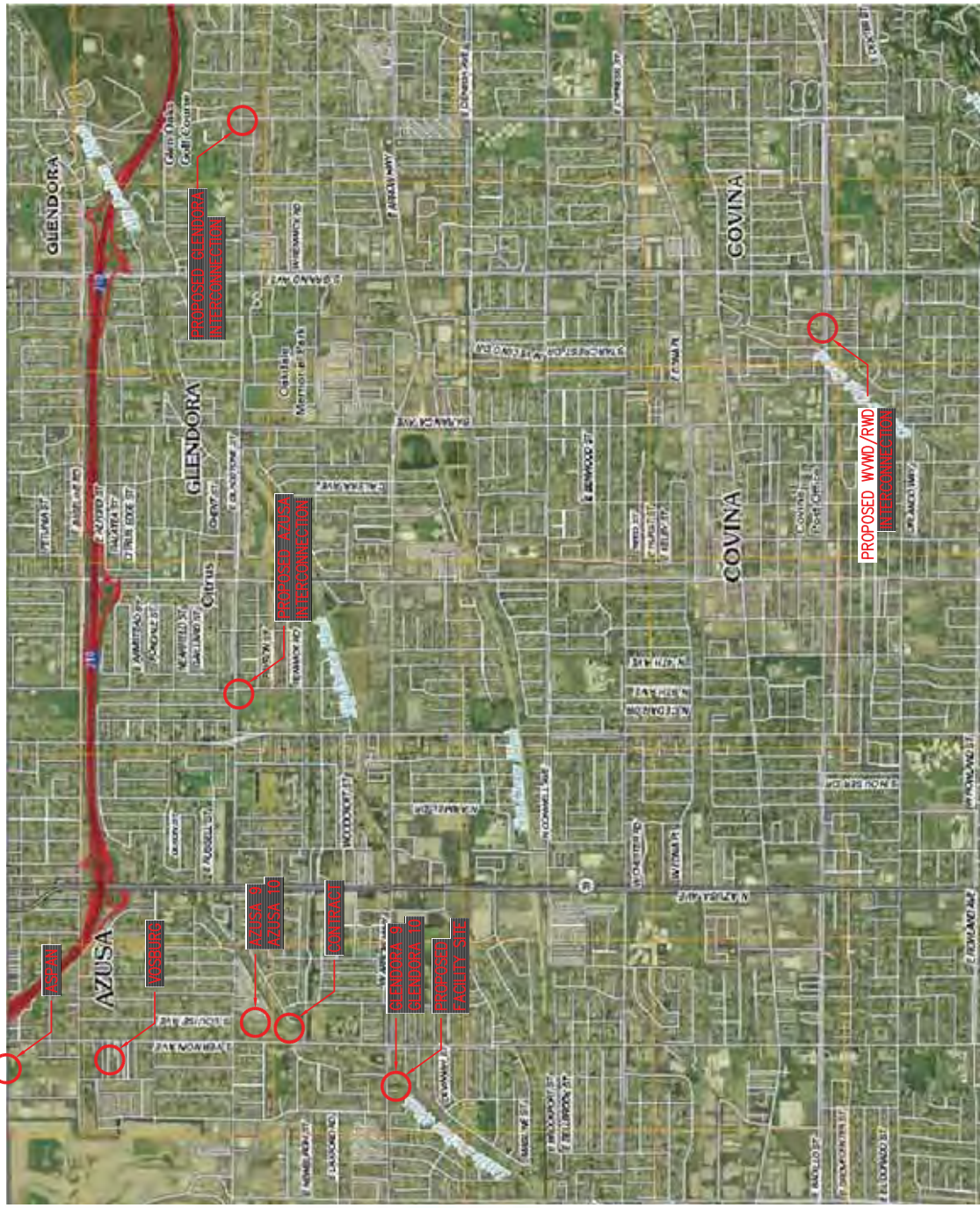

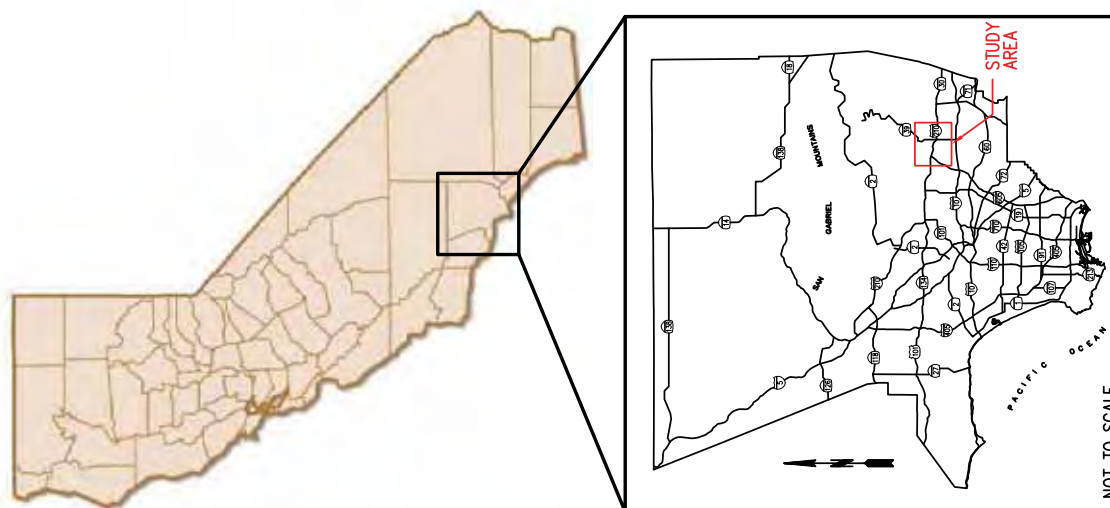

The study area includes portions of the Cities of Azusa, Covina and Glendora as shown in Figure 1. Included within the study area are the well sites, the proposed treatment plant site, the proposed interconnections with ALW, Glendora and WVWD, and the proposed alignments for the raw water collection system, ancillary treatment plant waste discharge system and the treated water distribution system. The project will influence water systems and respective service areas of ALW, Glendora, WVWD and RWD although the construction of proposed infrastructure will be limited to the area shown in Figure 1.



NOT TO SCALE



NOT TO SCALE

    	<p>PREPARED BY:</p>  <p>Civiltec engineering inc.</p> <p>General Civil, Municipal, Water and Wastewater Engineering, Management and Surveying 118 West Lima Avenue Morroville, CA 91016 Phone: (650) 357-0588 Fax: (650) 357-7957</p>	<p>FIGURE</p>	<p>1-1</p>
	<p>MULTI-AGENCY REGIONAL GROUND WATER RECOVERY PROJECT</p>	<p>STUDY AREA</p>	



**FEASIBILITY STUDY FOR THE MULTI-AGENCY REGIONAL GROUNDWATER RECOVERY PROJECT-100% DRAFT**

**1.3 Scope of Report**

The Scope of Work has been developed to establish the basic needs of the study so that the technical feasibility of the project is documented. The scope consisted of performing research through coordination with the respective agencies involved and review of documentation. The review focused on impacts of contamination of the basin, ground water rights, environmental considerations for constructing the facility, and existing conditions to establish a basis for the study. Analysis was performed to establish a framework for executing the study and ultimately developing the report. The following paragraphs identify the detailed steps taken to formalize the study.

A workshop was arranged and conducted with project participant’s Management and Staff to formalize study criteria and to discuss the operation of the groundwater recovery system. A field review was subsequently performed of the potential pipeline alignments and potential facility sites.

Focused research was performed of the existing water systems, of the proposed new treatment plant site, the wells and facilities. Record drawings and other relevant data such as water master plans; water quality data were also reviewed to develop a firm system understanding. The objective of this exercise was to obtain enough record information to identify potential issues that would need to be considered for the future construction the facility. Review of geologic reports/maps, basin management reports, regional water supply reports, assessor maps among other data was performed to determine rights-of-way for screened pipeline alternatives, potential site locations and overall system needs.

The team researched issues relating to conformity with economic and environmental principles and guidelines for water and related land resources implementation studies including the San Gabriel Basin Water Quality Authority (WQA), Department of Public Health (DPH), National Pollutant Discharge Elimination System (NPDES), Los Angeles County Sanitation District (LACSD), California Environmental Quality Act (CEQA) and other applicable local, state and federal laws and regulations for permitting requirements.

Base maps were created for the study and served as a foundation for developing exhibits that identify infrastructure alternatives for the project. Base maps were generated to incorporate those areas necessary for determining the pipeline alignment for connection to RWD and WWWD facilities. This effort identified general right of way lines along these alignments and for a potential outfall for brine waste discharge.

Data was analyzed through the research phase to develop the treatment and supply concept for consideration in the project. The concept was developed to consider the treatment processes and alternatives for collection and diversion of flow from the existing seven (7) wells that will be pumped to and from the treatment system; Water quality parameters (average, design range, and Maximum Contaminant Levels); Treatment



**FEASIBILITY STUDY FOR THE MULTI-AGENCY REGIONAL GROUNDWATER RECOVERY  
PROJECT-100% DRAFT**

requirements for water contaminants including high concentrations of perchlorate ( $\text{ClO}_4$ ), volatile organic compounds (VOC's), and nitrate ( $\text{NO}_3$ ); Description of water treatment processes comprising bacteriological, Ion Exchange, Liquid-Phase Granular Activated Carbon Adsorption (LGAC) recognized by the USEPA as Best Available Technologies (BAT); Chlorine disinfection for treated water and clear wells to ensure adequate contact time before discharge to the distribution systems as well as an adequate storage volume for distribution pumping.

Evaluation of various site plans was performed to accommodate unit processes at the appropriate locations meeting the needs and objectives of the project. A description of structures, features including treatment plant buildings was developed for the selected treatment method. The team reviewed issues relating to site security, necessary pump equipment withdrawing water from existing wells into the treatment plant and to the distribution system. Systems were selected based on the operating head and flow to maximize pump efficiency and coordinated with all aspects of the operation of the water supply system including the water treatment processes and piping systems.

The team utilized the hydraulic models of the ALW, Glendora and WVWD systems to ensure that production to and from the treatment plant is efficient and well planned for long-term operation and viability. Each participants needs are different and this effort segmented the respective needs to develop piping configurations that best meet these needs. This effort was limited to running the model under two different scenarios for each participants system.

Cost estimates, study topics, tasks, deliverables, exhibits and milestones were developed for the screened alternatives. The cost estimates are broken into shared agency benefits and portions of the project that only benefits each agency alone.

An analysis of arrangements and agreements as next steps among the project participants was performed to identify respective participant needs for involvement through the process and ultimate description of each agencies level of participation in the project.

The study identified the strengths and weaknesses of each portion of the project concept. The report summarizes the findings of the analysis performed and input from each of the project participants.





**FEASIBILITY STUDY FOR THE MULTI-AGENCY REGIONAL GROUNDWATER RECOVERY PROJECT-100% DRAFT**

**1.4 Abbreviations**

LACSD	Los Angeles County Sanitation District
ALW	Azusa Light and Water
Basin	Main San Gabriel Valley Water Basin
CDPH	California Department of Public Health
CERCLA	Comprehensive Environmental Response, Compensation and Liability Act of 1980
CICo	Covina Irrigating Company
<i>Civiltec</i>	<i>CIVILTEC Engineering Inc.</i>
CSDWA	California Safe Drinking Water Act
CWC	California Water Code
DCE	Dichloroethylene
DLR	Detection Limits for Purposes of Reporting
EPA	Environmental Protection Agency
GAC	Granular Activated Carbon
Glendora	City of Glendora
JPA	Joint Powers Agreement
MCL	Maximum Contaminant Level
MWD	Metropolitan Water District of Southern California
O&M	Operations and Maintenance
PCE	Tetrachloroethylene
ppb	parts per billion
ppm	parts per million
psi	pounds per square inch
RWD	Rowland Water District
SCAQDM	South Coast Air Quality Management District
SDWA	Safe Drinking Water Act of 1974
TCE	Trichloroethylene
TVMWD	Three Valleys Municipal Water District
USGS	United States Geologic Survey
UV	ultraviolet
VOC	Volatile Organic Compounds
WQA	San Gabriel Basin Water Quality Authority
WVWD	Walnut Valley Water District



**FEASIBILITY STUDY FOR THE MULTI-AGENCY REGIONAL GROUNDWATER RECOVERY  
PROJECT-100% DRAFT**

**1.5 Acknowledgments**

We, at *CIVILTEC engineering inc.* would like to express our appreciation for the cooperation and assistance of all the agencies and people involved with this study. In particular, the efforts provided by the following people proved to be invaluable:

- ◆ Chet Anderson - Azusa Light and Water
- ◆ Steve Seffer – Azusa Light and Water
- ◆ Steve Patton – City of Glendora
- ◆ David Davies, Director of Public Works. – City of Glendora
- ◆ Rick Hansen, General Manager – Three Valleys Municipal Water District
- ◆ Ken Deck – Rowland Water District
- ◆ Ted Carrera – Rowland Water District
- ◆ Mike Holmes - Walnut Valley Water District
- ◆ Erik Hitchman – Walnut Valley Water District
- ◆ David De Jesus, President – Covina Irrigating Company
- ◆ Grace Kast, Executive Director – San Gabriel Basin Water Quality Authority
- ◆ Carol Williams – Main San Gabriel Basin Watermaster
- ◆ Tony Zampielo - Main San Gabriel Basin Watermaster



**FEASIBILITY STUDY FOR THE MULTI-AGENCY REGIONAL GROUNDWATER RECOVERY  
PROJECT-100% DRAFT**

**Chapter 2 – Water Quality**

**2.1 Overview**

The San Gabriel Basin Water Quality Authority (WQA) adopted the San Gabriel Basin Groundwater Quality Management and Remediation Plan (§406 Plan) in February 2009 which outlines goals for cleanup of the Main San Gabriel Groundwater Basin (Basin). The four goals of the §406 Plan are:

- ◆ Accelerate Removal of Contaminant Mass in the Basin
- ◆ Prevent Migration of Contamination into Critical Groundwater Supplies
- ◆ Integrate Cleanup with Water Supply
- ◆ Minimize Economic Impact to the Public

Currently, the WQA is actively pursuing contamination cleanup projects in the Basin in coordination with the United States Environmental Protection Agency (EPA). The EPA has utilized the Comprehensive Environmental Response, Compensation and Liability Act of 1980 (CERCLA – also known as the Superfund program) as a vehicle to address funding and cleanup of the largest concentrations of well contamination. Cleanup efforts in the vicinity of the study area fall within the Baldwin Park Operable Unit (BPOU) shown in Figure 2-1.



NOT TO SCALE

- Well
  - Pipeline
  - Remedial Extraction Well
  - Treatment Plant
- Washes
- 2003 VOC Contamination
- Above defect to < MCL
  - MCL to < 10X MCL
  - 10X MCL to < 20X MCL
  - 20X MCL to < 100X MCL
  - 100X MCL to < 1000X MCL
  - Exceeding 1000X MCL

Source:  
 CH2M-Hill San Gabriel Database GIS  
 Prepared for EPA, 2007

**San Gabriel Basin  
 Water Quality Authority**

Updated: December 22, 2008

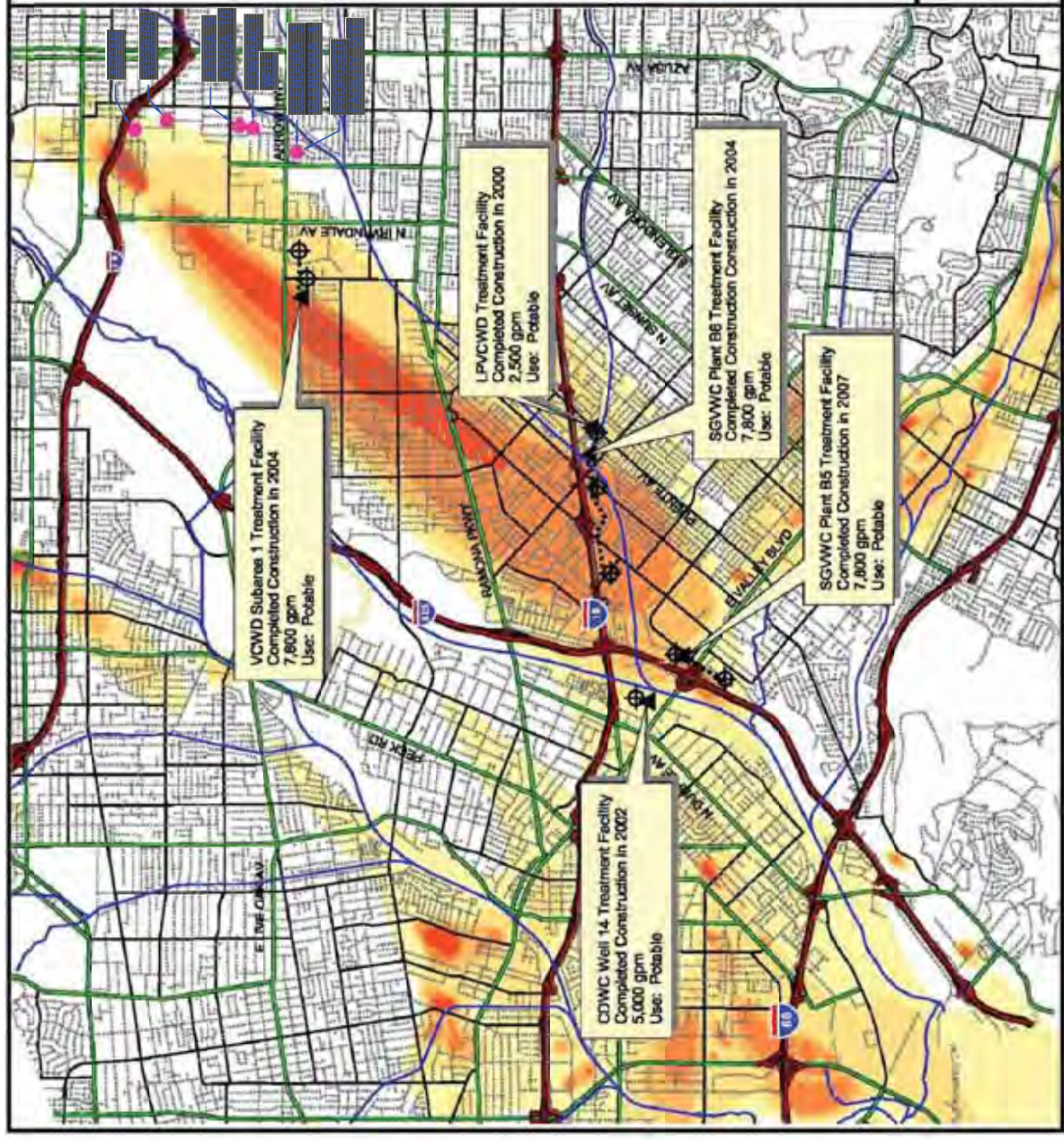

General Civil, Municipal, Water  
 and Wastewater Engineering,  
 Management and Surveying

118 West Lima Avenue  
 Moreno, CA 91016  
 Phone: (626) 337-6588  
 Fax: (626) 337-7957



FIGURE  
 MULTI-AGENCY REGIONAL GROUND WATER  
 RECOVERY PROJECT

WELL LOCATION WITHIN BALDWIN PARK OPERABLE  
 UNIT (EXCEPT FROM WQA § 406 PLAN)



**FEASIBILITY STUDY FOR THE MULTI-AGENCY REGIONAL GROUNDWATER RECOVERY  
PROJECT-100% DRAFT**

Of the contaminated areas in the Basin, the BPOU is considered the most significant because of its geographic size and degree of contamination. For this reason, the EPA prioritized this area for investigation back in the late 1980's. By 1994, there was a general consensus on the technical approach including a financial arrangement whereby sales from the water produced by the treatment plant would be used to offset the costs of the project. However, just as designs were being prepared, the discovery of new contaminants prompted a complete reevaluation of cleanup plans. In 1997, perchlorate, a contaminant derived from rocket fuel and other sources, was discovered in many of the active production wells within the BPOU. This discovery had widespread impacts, primarily because traditional treatment methods were ineffective in removing perchlorate from the groundwater. The new discovery not only disrupted the design of the CERCLA remedy, but also shut down many of the existing treatment plants that had been operating for water supply purposes. In one case, the entire water supply of the La Puente Valley County Water District (LPVCWD) was shut down due to excessive concentrations of perchlorate that could not be removed by treatment facilities then in place. This forced the LPVCWD to buy alternative groundwater supply from neighboring water purveyors and supplemental imported water at five times the cost of groundwater before the discovery of perchlorate. Based on the discovery of perchlorate, the EPA chose to update its Record of Decision (ROD) and issue a plan update. This update was similar to the original ROD except that the containment requirement in the southern portion of the BPOU was shifted further down gradient to address the new contaminants and the larger VOC plume resulting from several years of movement since the original ROD was issued. The EPA's plan required that about 22,000 gpm of contaminated groundwater be extracted and treated. The update did not, however, specify how the water was to be used.

In 1998, although the EPA had recently accepted a "good faith offer" from a portion of the BPOU Potential Responsible Parties (PRP) to conduct the required cleanup, the specifics of the offer suggested that the PRPs intended to construct cleanup facilities without addressing the local water supply needs. The promise of the good faith offer was to extract water from the specified locations, treat the water at centralized facilities using emerging but unapproved treatment technology and then discharge the water into nearby surface water channels. This approach was met with strong resistance that could have resulted in further delays and continuance of the existing water supply crisis. In addition, the EPA's approach focused on overall containment of the plume and did not include projects that were outside of the EPA's primary objectives that would have beneficial effects on both cleanup and water supply. In response to this situation, WQA prescribes a cleanup plan developed by the Main San Gabriel Groundwater Basin Watermaster (Watermaster) that integrates cleanup and water supply objectives. The first phase of this plan focused on the southern portion of the plume where the priority is highest to contain the plume, protect critical water supplies and restore critical water supplies. In 1999, due to the critical need for immediate action, WQA, the Watermaster and the Upper San Gabriel Valley Municipal Water District (USGVMWD) joined resources and began



**FEASIBILITY STUDY FOR THE MULTI-AGENCY REGIONAL GROUNDWATER RECOVERY  
PROJECT-100% DRAFT**

implementation of the plan by constructing the first facility to treat both perchlorate and N-Nitrosodimethylamine (NDMA) for drinking water at the LPVCWD well site. Following the success of the LPVCWD project, WQA prescribed additional early actions that build on the LPVCWD project development model. In 2002, eight of the 20 BPOU PRPs entered into a comprehensive project agreement with WQA, the Watermaster and local purveyors to fund a series of prescribed remedies.

Although contaminated, the wells identified in this report do not fall directly under the CERCLA cleanup initiative because more critically contaminated areas that meet all of the four goals set forth in the §406 Plan must take precedence. However, WQA’s determination that cleanup of these wells will help to improve the water quality within the Basin provides a framework for the importance of this project from a water quality point of view. The cleanup of these wells will satisfy the third goal established in the §406 Plan by integrating basin cleanup with supply and has the potential to satisfy the fourth goal of minimizing economic impact to the public by providing a reliable low-cost local water supply.

## **2.2 Description of Wells**

### **Azusa 9**

Azusa Well Number 9 is owned and operated by ALW and is located in the vicinity of 710 W. Gladstone Street. The well has concentrations of perchlorates and nitrates above the MCL and was removed from service prior to 1993 according to the City of Azusa 2005 Water Master Plan (ALW WMP). When in operation, Azusa 9 had a capacity of 4,700 gpm. Due to the time Azusa 9 has been out of service, reevaluation of capacity is warranted prior to implementation.

### **Azusa 10**

Azusa Well Number 10 is owned and operated by ALW and is located at the same site as Azusa 9 in the vicinity of 710 W. Gladstone Street. The well has concentrations of perchlorates and nitrates above the MCL and is currently active, producing approximately 2,200 gpm. With the implementation of the treatment facility this well should be reevaluated and inspected prior to treatment.

### **Aspan**

The Aspan Well is owned and operated by ALW and is located in the vicinity of 244 N. Aspan Avenue. The VOC concentrations of this well are above the MCL. In addition, there are trace amounts of radioactivity noted at this location. The Aspan well was removed from production in 1984. At that time, the Aspan Well was producing approximately 3,100 gpm. At the same site there is a 2 million gallon reservoir; however, this reservoir has been inactive since 1984. Although the Aspan Well has been out of



**FEASIBILITY STUDY FOR THE MULTI-AGENCY REGIONAL GROUNDWATER RECOVERY  
PROJECT-100% DRAFT**

service test pumping and a water quality analysis was performed in 2008. At that time the well casing and screen was video inspected and determined to be in serviceable condition.

**Glendora 3**

Glendora Well Number 3 is owned and operated by the City of Glendora and is located in the vicinity of 16734 W. Arrow Highway. Glendora 3 has concentrations of VOCs, perchlorates and nitrates above the MCL and was removed from service in the early 1980's. When in operation, Glendora 3 had a capacity of approximately 2,000 gpm. Due to the duration of time that Glendora 3 has been out of service, reevaluation of capacity is warranted prior to implementation.

This site is the ideal location for the proposed treatment plant as further discussed in this study. In addition to Glendora 3, the site includes Glendora Well Number 4 and a temporary 0.15 million-gallon storage tank for well discharge. The tank has also been inactive since the early 1980's and will need to be replaced prior to its possible use as a component of the treatment plant.

**Glendora 4**

Glendora Well Number 4 is owned and operated by the City of Glendora and is located at the same site as Glendora 3 in the vicinity of 16734 W. Arrow Highway. Glendora 4 has concentrations of VOCs, perchlorates and nitrates above the MCL and was removed from service in the early 1980's. When in operation, Glendora 4 had a capacity of approximately 2,000 gpm. Due to the time Glendora 4 has been out of service, reevaluation of capacity is warranted prior to implementation.

**Vosburg**

The Vosburg Well is owned and operated by the City of Glendora and is located in the vicinity of 182 S. Virginia Avenue. It was removed from service in the early 1980's due to high concentrations of VOCs. A recent water quality analysis indicated that the VOCs are still present and that perchlorate and nitrate concentrations are above the MCL as well. When in operation, the Vosburg Well had a capacity of approximately 2,300 gpm. Due to the duration of time that the Vosburg Well has been out of service, reevaluation of capacity is warranted prior to implementation.



**FEASIBILITY STUDY FOR THE MULTI-AGENCY REGIONAL GROUNDWATER RECOVERY  
PROJECT-100% DRAFT**

**Contract Well**

The Contract Well is owned and operated by the Covina Irrigating Company and is located in the vicinity of 5500 N. Lark Ellen Avenue. The CICO has an agreement with the agencies involved for use of this well in the treatment facility’s system. However, no provisions to deliver treated water to CICO are included in this study. The Contract Well has concentrations of perchlorates, nitrates and VOCs above the MCL and was removed from operation. Prior to being removed from service the well had a capacity of approximately 2,400 gpm. Although the Contract Well has been out of service only a short time, reevaluation of capacity may be warranted prior to implementation. The Contract Well site includes a holding tank.

**2.3 Occurrence of Contaminants**

According to the §406 Plan, the Basin is one of the most contaminated in the nation. This contamination dates back to the disposal of solvents and other industrial wastes during and after World War II. While these contaminants are spread throughout the basin, the highest concentrations have been reported to be located in a centralized plume bounded by the I-210 Freeway to the north, the I-10 Freeway to the south, the I-605 Freeway to the west and Irwindale Avenue to the east. The plume is flowing in a southwesterly direction following the San Gabriel River; however, the contaminants are also spreading out in all directions. The wells identified in this report are currently located easterly of the plume and will not be directly affected by the flow. However, since the plume is also expanding in all directions, these wells could be affected in the future as the contaminants are drawn into each well’s cone of influence. Figure 2-2, obtained from the §406 Plan, depicts the locations of the wells in relation to the contamination plume and Appendix B includes water quality reports and histories of the respective wells.



# San Gabriel Basin Contamination

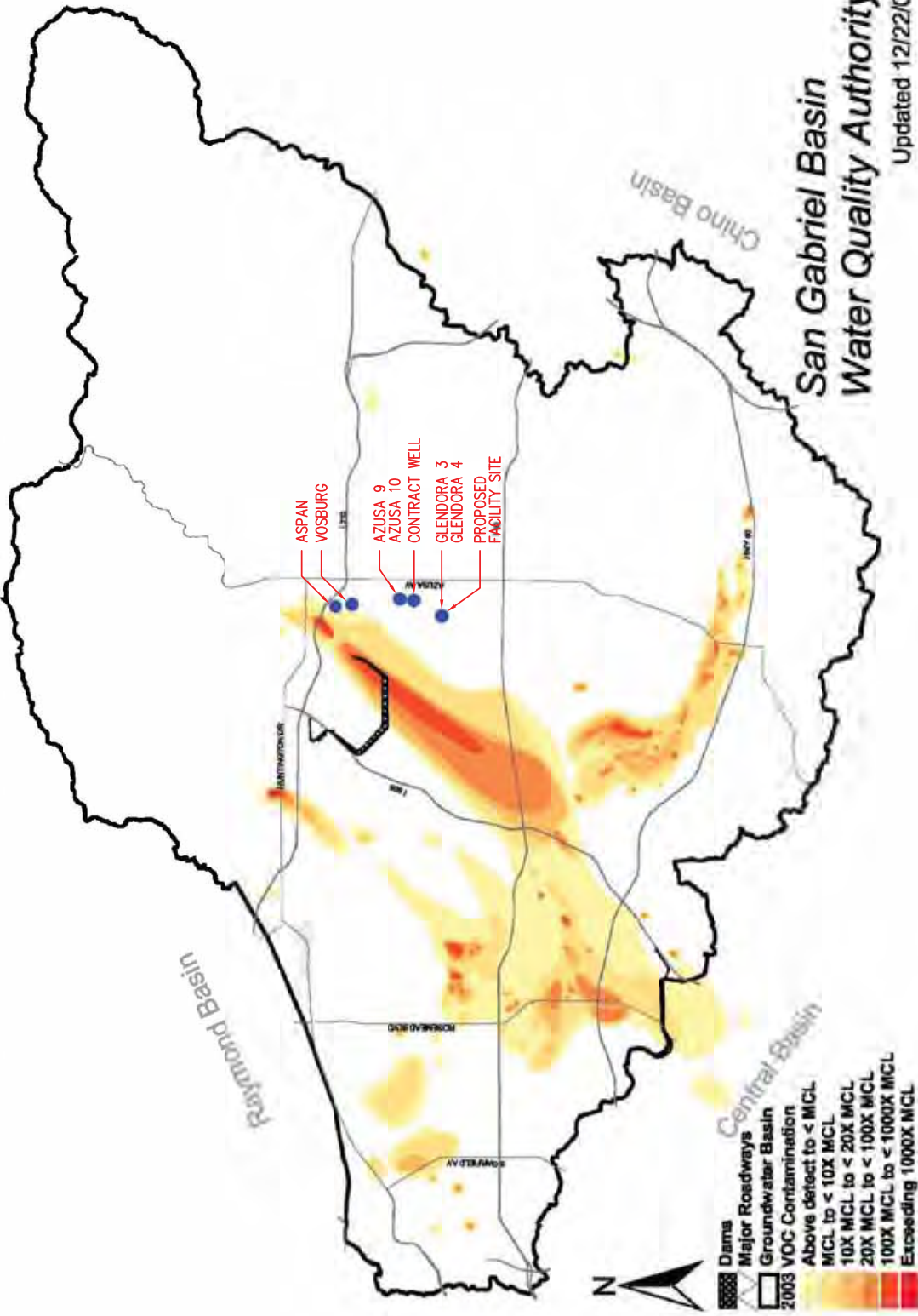

NOT TO SCALE



PREPARED BY:  
**CIVILTEC**  
engineering, inc.

General Civil, Municipal, Water  
and Wastewater Engineering,  
Management and Surveying  
118 West Lima Avenue  
Morroville, CA 91016  
Phone: (650) 337-6588  
Fax: (650) 302-7957

MULTI-AGENCY REGIONAL GROUND WATER  
RECOVERY PROJECT

WELL LOCATION IN RELATION TO  
SAN GABRIEL BASIN CONTAMINATION PLUME  
(EXCERPT FROM WQA § 406 PLAN)

FIGURE

2-2



**FEASIBILITY STUDY FOR THE MULTI-AGENCY REGIONAL GROUNDWATER RECOVERY PROJECT-100% DRAFT**

The contaminants within the plume are mainly VOCs; however, due to the historical production and use of agricultural fertilizer, rocket fuels and other solvents, perchlorate and nitrate contamination is also present. Information on well contamination was obtained from water quality analyses conducted in 1999 and 2008 (Appendix C). Table 2-1 contains a summary of the contaminant concentrations of each well. Concentrations in violation of the Maximum Contaminant Level (MCL) are shown in red print.

**Table 2-1: Contaminant Concentration Summary**

Source	Flow (gpm)	Nitrate as NO <sub>3</sub> (mg/L)	Perchlorate (ug/L)	VOC-PCE (ug/L)	VOC-TCE (ug/L)	VOC-DCE (ug/L)	Uranium (pCi/L)	Gross Alpha (pCi/L)
MCL <sup>1</sup>	n/a	45	6	5	5	6	20	15
DLR <sup>2</sup>	n/a	2	4	0.5	0.5	0.5	1	3
Azusa 9	4,782	85	14	0	0	0	0	0
Azusa 10	2,216	61	10	0.82	0	0	0	0
Aspan	3,135	15.9	0	1	3.7	18	3.3	4.1
Glendora 3	2,050	133	13	0	0	0	0	0
Glendora 4	2,000	86	14	0	0	0	0	0
Vosburg	2,300	106	5.23	2.3	0	0	0	0
Contract	2,400	111	14	2.2	0	0	0	0
Blended Concentrations <sup>3</sup>	18,883	82.94	11.72	0.54	0.61	2.99	0.55	0.68

1 – Maximum Contaminant Level  
 2 – Detection Limits for Purposes of Reporting  
 3 – Assumes all maximum well discharges are combined

The concentrations of perchlorates found in the individual wells range from about 5 to 14 µg/L, and the blended concentration is approximately 12 µg/L. Virtually all of these concentrations are above the MCL of 6 µg/L; therefore, a treatment process for perchlorate removal will be required.

The concentration of VOC-DCE in the Aspan Well is in excess of the MCL. However, blending the production from this well with various combinations of the other wells will reduce the concentration of VOC-DCE to below the MCL. As calculated in the bottom row of Table 1, with all wells at maximum production capacity the concentration of VOC-DCE is approximately 3 µg/L which is below the MCL of 5 µg/L. To maintain a target concentration of 80% of the MCL (i.e. 4 µg/L) with the Aspan Well at maximum capacity, a minimum combined flow rate of approximately 14,100 gpm is required:

$$Q_{required} = Q_{Aspan} \frac{C_{Aspan}}{C_{target}} = (3,135 \text{ gpm}) \left( \frac{18}{4} \right) \cong 14,100 \text{ gpm}$$



**FEASIBILITY STUDY FOR THE MULTI-AGENCY REGIONAL GROUNDWATER RECOVERY  
PROJECT-100% DRAFT**

With the exception of the Aspan Well, the individual well concentrations of VOC-PCE and VOC-TCE are below the MCL. No specific treatment for these two contaminants in the 6 other wells is necessary prior to distribution as potable water as presented in current water quality reports. However the occurrence of VOC contamination is likely to increase within these wells as production resumes.

The concentrations of nitrates found in the individual wells vary from 60 to 135 mg/L, and the blended concentration is approximately 83 mg/L. All of these concentrations are above the MCL of 45 mg/L; therefore, a treatment process for nitrate removal will be required.

Another consideration involving the blending of VOC-DCE includes the continued monitoring of concentrations throughout the well field and restricting the production at the Aspan Well to accommodate various blending scenarios as needed. Monitoring for VOC contamination is prudent given the proximity of the well field to the VOC plume as indicated in the Figure 2-1. It is recommended to simulate the impact of reactivating the wells considered in this study on the plume using a hydrogeologic model of the Basin.

The radionuclides uranium and gross alpha were detected in the Aspan Well; however, their concentrations are below the MCL. It should be noted that these ions may accumulate in the medium of an ion exchange treatment process rendering the medium a hazardous material. This material may then require a special disposal process during routine maintenance and recharging of the treatment vessels. Resins loaded to a concentration of 500 mg/kg (ppm) of these radionuclides are considered source nuclear material.

## **2.4 Contaminant Regulation**

The Safe Drinking Water Act (SDWA) was passed by Congress in 1974, with subsequent amendments in 1986 and 1996, to ensure and protect the quality of American’s drinking water. Under SDWA, the United States Environmental Protection Agency (EPA) is given authority to set the standards for drinking water quality and oversee states, localities, and water suppliers who implement those standards.

Through the SDWA, all public water systems in the United States need to follow the standards and regulations set by the EPA. The EPA has set maximum contaminant levels (MCLs) and/or treatment technique requirements for over 90 different contaminants in public drinking water.

In concurrence with the SDWA, the State of California enacted its own safe drinking act (Health & Safety Code 116275 et seq.) to be overseen by the California Department of Public Health (CDPH). The California Safe Drinking Water Act (CSDWA) authorizes the CDPH to set permit conditions for water delivered by public systems. The intent of this authority is to ensure that the water delivered by public water systems of this state



**FEASIBILITY STUDY FOR THE MULTI-AGENCY REGIONAL GROUNDWATER RECOVERY  
PROJECT-100% DRAFT**

shall at all times be pure, wholesome, and potable. In addition, this legislation provides the CDPH with the authority to establish a drinking water regulatory program that includes drinking water standards (MCLs) and public health goals. The standards set forth by the CDPH are more stringent than those of the SDWA and are enforceable. The public health goals are more stringent than the water standard MCLs but are currently not an enforceable standard for public supply systems.

**2.5 Discussion of Regulatory Environment**

The California Environmental Quality Act (CEQA) was adopted by the state in 1970. One of the main purposes of CEQA is to inform the governmental decision makers and the public about the potential environmental impacts associated with proposed projects. The CEQA study is an analysis of 17 different environmental factors that are potentially affected. The factors are evaluated based on the significance of potential impacts from “no impact” to “potentially significant impact”. Although all 17 factors will need to be reviewed, the main factors *Civiltec* anticipates will be impacted for this treatment plant and require documentation will be as follows:

- ◆ **Aesthetics** – This factor will review the visual impacts of new structures, their heights and the impacts they will have on the surrounding views in the vicinity of the treatment plant. It will also consider light and glare issues that could be created by the structures.
- ◆ **Biological Resources** – The biological resources factor will require a survey of the project site and immediately surrounding area for the presence of special status plants and animals.
- ◆ **Air Quality** – The main purpose of this factor is to bring the project into compliance with the requirements of federal and state air quality standards. This will include an analysis of construction activity emissions as well as an estimate of the emissions created during long term operation of the treatment plant. The results of this analysis will determine the type of impact and possible mitigation measures required to not exceed the South Coast Air Quality Management District (SCAQMD) and CEQA air quality significance thresholds.
- ◆ **Hazardous Materials** – The hazardous materials factor addresses the impact the project will have on the public and environment through transportation, usage, storage and disposal of hazardous materials. This also takes into account the potential safety hazards imposed by the project to schools, public airports, emergency response/evacuation plans and wild land fires.
- ◆ **Cultural Resources** – The cultural resources factor requires the study of cultural and paleontological resource records to determine if there are any historical structures, land marks or fossils that may be impacted. Based upon the findings in the research, a possible survey of the site and surrounding area could be required.



**FEASIBILITY STUDY FOR THE MULTI-AGENCY REGIONAL GROUNDWATER RECOVERY  
PROJECT-100% DRAFT**

- ◆ **Hydrology and Water Quality** – The hydrology and water quality factor analyzes the impact the project will have to the existing drainage patterns and the overall water quality within the immediate area. This includes any additional flows imposed on the local sewer/drainage systems and their capacity to accept the additional flow.
- ◆ **Noise** – This factor studies the possibility of exposing persons to the generation of noise levels in excess of the local noise ordinances. This includes ground-borne vibrations or noise, and increases to permanent and temporary ambient noise levels surrounding the project site.
- ◆ **Geology and Soils** – The geology factor will require a study of the site and surrounding area for possible seismic activity including the earthquake zone established by Los Angeles County. The soils factor will require a study for possible liquefaction, settlement, expansion and landslides.
- ◆ **Land Use and Planning** – This factor will require an analysis of the local land use plans and zoning ordinances of the jurisdiction in which the project is located.
- ◆ **Transportation and Traffic** – This factor determines if the project will impose a substantial impact to the existing traffic load surrounding the site. This includes, but is not limited to, land closures, detours, adverse geometric alignment adjustments, parking capacities and emergency access.
- ◆ **Mandatory Findings of Significance** – This factor studies the potential of the project to degrade the quality of the environment. This includes the direct and indirect impacts to human beings, fish and wildlife populations, plant species or important examples of major periods of California history/prehistory.

The intensity of the study required will be determined based upon the significance of these potential impacts. Less significant impacts can be addressed in negative declaration (ND) or mitigated negative declaration (MND) studies; larger more significant impacts will require an environmental impact report (EIR).

***City Permitting***

Currently the best site location for the treatment facility is located within the City of Azusa. Therefore, permitting with the City of Azusa for construction of the treatment facility will be required. It is possible the site utilized could be zoned differently than what is required for groundwater treatment; in such a case, a Conditional use Permit (CUP) may be required as well as a building permit.

- ◆ **CUP:** The purpose of a CUP is to obtain approval from City of Azusa to construct the facility at a location under a different zoning ordinance. To obtain a CUP, an application process is required. As a condition to the application, identifying the CEQA impacts that will affect the site is required; as well as, the MND or EIR that will be utilized on the determined impacts.
- ◆ **Building Permit:** If a structure is to be constructed, a building permit will be required to ensure all applicable building codes are satisfied. The building permit



**FEASIBILITY STUDY FOR THE MULTI-AGENCY REGIONAL GROUNDWATER RECOVERY PROJECT-100% DRAFT**

will also include the approval for a number of elements associated with the project, for example: traffic control, construction staging, grading and storm water approvals.

***Los Angeles County Sanitation District***

Some treatment processes require regeneration through the use of a brine solution. Once the regeneration process is complete, the waste brine will need to be disposed of. Such waste is usually discharged to an industrial waste sanitary sewage system. Currently, the closest industrial waste sewer line to the wells, are the *Irwindale Trunk Sewer Section No. 3* of the Los Angeles County Sanitation District (LACSD). To connect into this sewer pipeline, a permit will be required from the LACSD. To obtain the permit, an analysis of the wastewater for chemical oxygen demand (COD), solids and the amount of flow to be discharged must be documented with LACSD. Once the connection is approved, a fee will be imposed upon the project based upon the results of the analysis. The current rate is \$3,099 per capacity (a capacity is defined by COD, solids and flow rate) and is expected to increase 20 percent starting July 1, 2010. According to the Section Head of the Industrial Waste Section for LACSD, the following simplified equation can be utilized to determine capacity for brine lines:

$$\frac{\text{Average Daily Flow (gpm)}}{260} \times 0.7 = \text{Capacity}$$

***California Department of Public Health***

The CDPH regulates all public drinking water systems. The groundwater within the study area may be considered by the CDPH to be an extremely impaired drinking water source. CDPH characterizes an extremely impaired source as one that meets one or more of the following criteria:

- ◆ Exceeds 10 times an MCL or action level (AL) based on chronic health effects,
- ◆ Exceeds 3 times an MCL or AL based on acute health effects
- ◆ Is a surface water that requires more than 4 log *Giardia*/5 log virus reduction,
- ◆ Is extremely threatened with contamination due to proximity to known contaminating activities
- ◆ Contains a mixture of contaminants of health concern
- ◆ Is designed to intercept known contaminants of health concern

Due to the close proximity of the study area to the BPOU a mix of contaminants of health concern are present in the underlying aquifer. Therefore, an evaluation of Policy Memo 97-005 should be performed considering existing documentation of the BPOU 97-005 to determine the need for developing guidance under these requirements. Upon approval of this evaluation, CDPH will notify the project participants of the need to prepare a 97-005.



**FEASIBILITY STUDY FOR THE MULTI-AGENCY REGIONAL GROUNDWATER RECOVERY  
PROJECT-100% DRAFT**

An operating permit will ultimately include all necessary treatment, compliance monitoring, operational, testing, sampling and reporting requirements for the facility.

During initial startup of the treatment facility, startup following system maintenance activities and startup after extended periods of downtime, it will be necessary to discharge treated water from the system. It is anticipated that startup and testing of the production wells and treatment system will last for several days and produce large volumes of water that will not be able to be discharged to the distribution system until final approval has been obtained from the CDPH. Similarly, large volumes of purge water will be produced during annual well startup and testing. During these periods, the treated water will be discharged to the Little Dalton Wash.

***Regional Water Quality Control Board***

General Waste Discharge Requirements (WDR) associated with discharge of treated groundwater to surface water during remedial activities is provided by the Los Angeles Regional Water Quality Control Board (RWQCB) in Order Nos. R4-2007-0022, *Waste Discharge Requirements for Discharges of Treated Groundwater from Investigation and/or Cleanup of Volatile Organic Compound Contaminated Sites to Surface Waters in Coastal Watersheds of Los Angeles and Ventura Counties* (RWQCB, 2007), and No. R4-2003-0108 *Waste Discharge Requirements for Discharges of Groundwater from Potable Water Supply Well to Surface Waters in Coastal Watersheds of Los Angeles and Ventura Counties* (RWQCB, 2003). These general WDRs are applicable to the discharges of utility water during startup and operation of the treatment facility. The requirements contained in Order Nos. R4-2007-002 and R4-2003-0108 are consistent with all water quality control policies, plans, and regulations in the California Water Code (CWC) and the revised *Water Quality Control Plan for the Los Angeles Region* (RWQCB, 1994). Therefore, this treatment facility will comply with the substantive requirements contained in Order Nos. R4-2007-0022 and R4-2003-0108 when discharging utility water to the Little Dalton Wash.



**FEASIBILITY STUDY FOR THE MULTI-AGENCY REGIONAL GROUNDWATER RECOVERY  
PROJECT-100% DRAFT**

***Waste Management***

The primary wastes generated from construction and operation of the facility will include the following:

- ◆ Sediment from production well repairs,
- ◆ Water from purging the production wells,
- ◆ Excavated soil from construction of the concrete treatment pad,
- ◆ Spent ion exchange resin and GAC media, and
- ◆ Treated waste water from startup, operation and maintenance of the treatment system.

The amount of waste generated will vary based on actual field operations. Waste water will be sampled and discharged in accordance with all permit requirements. Solid wastes will be characterized and classified as hazardous or non-hazardous waste based on the laboratory results in accordance with the Code of Federal Regulations (40 CFR 261.31 to 261.33 and 261.21 to 261.24) and the California Code of Regulations (22 CCR). An appropriate U.S. EPA-certified waste disposal facility and licensed transporter will be selected for off-site waste transportation and disposal. All waste transported off-site will be accompanied by the appropriate hazardous or non-hazardous waste manifests. The disposal of waste will be in accordance with Federal, state, and local laws, regulations, and instructions.

***Storm Water Pollution Prevention Plan***

Construction of the proposed project has the potential to contribute minor amounts of additional sediment into existing site runoff during grading and construction activities. The State Water Resources Control Board (SWRCB), Division of Water Quality, issues the NPDES storm water permit for general construction activities. The Los Angeles Regional Water Quality Control Board (LARWQCB) enforces the NPDES program for the State of California within its jurisdiction. Dischargers whose projects disturb one or more acres of soil are required to obtain coverage under the General Permit for Discharges of Storm Water Associated with Construction Activity (Construction General Permit, 99-08-DWQ). Because the proposed area of disturbance may be more than one acre, coverage under this permit would be required.

Coverage under the Construction General Permit is accomplished by completing and filing a Notice of Intent with the SWRCB and by preparing and implementing a Storm Water Pollution Prevention Plan (SWPPP) prior to grading. The primary objective of the SWPPP is to identify, construct, implement, and maintain Best Management Practices (BMPs) to reduce or eliminate pollutants in storm water discharges from the construction site. Construction BMPs may include, but not be limited to:





**FEASIBILITY STUDY FOR THE MULTI-AGENCY REGIONAL GROUNDWATER RECOVERY  
PROJECT-100% DRAFT**

- ◆ Sediments generated on the project site shall be retained using adequate Treatment Control or Structural BMPs;
- ◆ Construction-related materials, wastes, spills or residues shall be retained at the project site to avoid discharge to streets, drainage facilities, receiving waters, or adjacent properties by wind or runoff;
- ◆ Non-storm water runoff from equipment and vehicle washing and any other activity shall be contained at the project site; and
- ◆ Erosion from slopes and channels shall be controlled by implementing an effective combination of BMPs (as approved in Regional Board Resolution No. 99-03), such as the limiting of grading scheduled during the wet season; inspecting graded areas during rain events; planting and maintenance of vegetation on slopes; and covering erosion susceptible slopes.

Implementation of the BMPs would reduce construction-related impacts to the maximum extent feasible. The potential for additional sediment in runoff, and the required permitting and BMPs, would be essentially the same for both alternatives.

***Standard Urban Storm water Mitigation Plan***

On December 31, 2001, the Los Angeles Regional Water Quality Control Board (Los Angeles RWQCB) adopted Order No. 01-182, the NPDES Permit (NPDES No. CAS004001) for municipal storm water and urban runoff discharges within the County of Los Angeles. The development planning program requirements, including the Standard Urban Storm water Mitigation Plan (SUSMP) requirements, were approved by the Los Angeles RWQCB pursuant to the requirements of the Municipal Separate Storm Sewer Systems (MS4) NPDES permit to address storm water pollution. The SUSMP contains a list of minimum BMPs that must be employed to infiltrate or treat storm water runoff, control peak flow discharge, and reduce the post-project discharge of pollutants from storm water conveyance systems for new construction and redevelopment in the County. The County of Los Angeles' *Manual for the Standard Urban Storm water Mitigation Plan* details the requirements for new development and significant redevelopment BMPs (LACDPW 2002).

The proposed project would comply with all SUSMP requirements, as implemented by City of Azusa Ordinance.

**2.6 Water Quality Goals**

The water quality goal of the project is to recover poor quality groundwater for domestic use by reducing contaminant concentrations to levels consistent with maximum contaminant levels (MCLs) set by the EPA and the CDPH. The target concentrations are 80% of the MCLs of 6 µg/L for perchlorate (ClO<sub>4</sub>), 5 µg/L for volatile organic compounds (VOCs), and 45 mg/L for nitrate (NO<sub>3</sub><sup>-</sup>). Maintaining contaminant levels below the MCLs will reduce known or expected health risks to acceptable levels





### FEASIBILITY STUDY FOR THE MULTI-AGENCY REGIONAL GROUNDWATER RECOVERY PROJECT-100% DRAFT

according to the EPA and CDPH. The water quality goal of this project is supported by numerous State and local agencies.

The California Water Code (CWC) Section 106 states that “the use of water for domestic purposes is the highest use of water and that the next highest use is for irrigation”. This project is consistent with the CWC’s highest use of water.

The WQA goals of integrating cleanup with water supply and minimizing economic impact to the public as laid out in the §406 Plan are consistent with the intent of this project. Furthermore, pending confirmation by simulation of the hydrogeologic model of the Basin, the other two goals of the §406 Plan (accelerate removal of the contaminant mass in the Basin and prevent migration of contaminant mass into critical groundwater supplies) may be accomplished in full or in part.

The water quality goals of the CDPH, as summarized by the Drinking Water Source Assessment and Protection Program (DWSAP), that are in common with this project include the following:

- ◆ Improve protection and benefit of public water systems of the State
- ◆ Improve drinking water quality and support effective management of water resources
- ◆ Inform communities and drinking water systems of contaminants and possible contaminating activities that may affect drinking water quality or the ability to permit new drinking water sources
- ◆ Encourage a proactive approach to protecting drinking water sources and enable protection activities by communities and drinking water systems
- ◆ Refine and target the monitoring requirements for drinking water sources
- ◆ Focus cleanup and pollution prevention efforts on serious threats to surface and ground water sources of drinking water
- ◆ Meet federal requirements for establishing wellhead protection and drinking water source assessment programs

Benefits beyond improving water quality include improvements to system reliability and redundancy as well as fostering integrated resource management in the region.



FEASIBILITY STUDY FOR THE MULTI-AGENCY REGIONAL GROUNDWATER RECOVERY  
PROJECT-100% DRAFT

**Chapter 3 – Properties, Sources and Health Risks of Contaminants**

**3.1 Chemical Properties**

**Volatile Organic Compounds (VOCs)**

Volatile organic compounds are compounds that have a high vapor pressure and low water solubility. Many VOCs are human-made chemicals that are used and produced in the manufacture of paints, pharmaceuticals, and refrigerants. VOCs typically are industrial solvents, such as trichloroethylene; fuel oxygenates, such as methyl tertiary-butyl ether (MTBE); or by-products produced by chlorination in water treatment, such as chloroform. VOCs are often components of petroleum fuels, hydraulic fluids, paint thinners, and dry cleaning agents. VOCs are common ground-water contaminants.

**Perchlorate ( $\text{ClO}_4^-$ )**

Perchlorate ( $\text{ClO}_4^-$ ) is both a naturally occurring and man-made chemical from the solid salts of ammonium, potassium, or sodium perchlorate. Ammonium perchlorate has been used as a fuel propellant for rockets, missiles, and fireworks. Wastes from the manufacture and improper disposal of perchlorate-containing chemicals are increasingly being discovered in soil and water. Perchlorate is very mobile in aqueous systems and it can persist under typical groundwater and surface water conditions for decades. Perchlorate interferes with the ability of the thyroid gland to utilize iodine to produce thyroid hormones.

**Nitrate**

Nitrate is the most highly oxidized form of nitrogen. Other forms of nitrogen in water may include compounds such as urea, amino acids, ammonia, ammonium ion, nitrogen gas and nitrite. Nitrogen is a major nutrient for vegetation and is an essential nutrient for all living organisms. Certain species of bacteria in soil, blue-green algae, and other aquatic microbes can capture atmospheric nitrogen and convert it to nitrate. Potential sources of nitrate in drinking water include runoff from fertilizer use, leaching from septic tanks, sewage, and erosion of natural deposits.



**FEASIBILITY STUDY FOR THE MULTI-AGENCY REGIONAL GROUNDWATER RECOVERY  
PROJECT-100% DRAFT**

**Radionuclides**

Uranium, radium, and radon are naturally occurring radionuclides found in the environment. These and other certain minerals are radioactive and are present in varying amounts in nearly all rocks, soils, and water. Natural and man-made radionuclides are unstable and undergo radioactive decay; they may emit forms of radiation known as alpha particles, beta particles, and photons (gamma rays). EPA has not classified uranium, radon or radium for carcinogenicity, but cancer is the major effect of concern from the radionuclides.

**3.2 Probable Sources**

Given the amount of contamination present in these wells and throughout the Basin, the main source of contamination is from several sources and various activities that have occurred in the area over the past 70 years. It is fairly certain the main source of the contamination in the plume is not from present day activities or waste disposal. According to the §406 Plan, the contamination dates as far back as World War II with the development of solid rocket fuels and storage of solvents. The area surrounding the contamination plume, as well as some of the wells, was also a major industrial complex. Since industrial sites tend to utilize solvents, explosive chemicals and many other highly reactive compounds there is a high probability this activity could also have contributed to the contamination.

In addition, there are also natural occurring contaminants. Perchlorates are a contaminant that occur naturally, although more commonly in arid locations and dried river beds. These natural perchlorates are typically formed through a reaction with sodium chloride from the sea and ozone gas or by exposing soils with high salt concentration to UV light; thereby, converting the chloride into perchlorate. The concentrations of natural perchlorates typically range between 1 and 10 mg/L.

VOCs can be found indoors and outdoors. The most common VOC is methane, a greenhouse gas sometimes excluded from analysis of other VOCs and using the term non-methane VOCs or NMVOCs. Major worldwide sources of atmospheric methane include wetlands, ruminants such as cows, energy use, rice agriculture, landfills, and burning biomass such as wood. Methane is the primary component of natural gas.

Common artificial VOCs include paint thinners, dry cleaning solvents, semiconductor cleaner, and some constituents of petroleum fuels (e.g. gasoline and natural gas). Trees are also an important biological source of VOC. It is known that trees emit large amounts of VOCs, especially isoprene and terpenes.



**FEASIBILITY STUDY FOR THE MULTI-AGENCY REGIONAL GROUNDWATER RECOVERY  
PROJECT-100% DRAFT**

Also, many VOCs are found in abandoned or underused industrial and commercial facilities whose expansion or redevelopment may be complicated by real or perceived environmental contaminations.

Another contaminant that occurs naturally is nitrates. Nitrates are a major source of nutrients for plants. Plants require nitrogen as a nutrient however cannot absorb it directly; therefore, bacteria convert the nitrogen gas into nitrate that will be absorbed by the plant. Since nitrate salts are water soluble, water flowing across the plant leaf or soil, from irrigation or precipitation, will drain the nitrates away prior to absorption.

Uranium contamination may occur due to proximity to a storage site for radioactive waste or from naturally occurring uranium. Typically, the concentration of uranium in the earth's crust and soils produces a concentration between 2 and 4 pCi/L. The Aspan Well has a concentration of 3.3 pCi/L which is consistent with naturally occurring uranium. The MCL for uranium concentrations in domestic water is 20 pCi/L.

### **3.3 Health Risks**

Perchlorates are oxidizers utilized in explosive applications such as automobile air bag deployment, solid rocket fuel and fireworks. Perchlorates can also occur naturally and are most prevalent in arid areas such as deserts. According to the National Academy of Science, perchlorate exposure in humans affects the thyroid and these affects can be reversed once exposure ceases.

PCE is a solvent most utilized in the dry cleaning industry. It also has some uses for degreasing metal parts in the metalworking and automotive industries. PCE is classified by the International Agency for Research on Cancer as a probable carcinogen to humans, meaning high concentrations can cause cancers in human beings, most notably leukemia and lymphoma.

TCE is a solvent utilized to extract vegetable oils from plant materials and as an anesthetic; however, its use as an anesthetic was discontinued due to slow patient recovery rates. National Cancer Institute research has shown that exposure to high concentrations of TCE is carcinogenic in animals, leading to liver and kidney cancers. Evidence of TCE exposure in drinking water has been linked to cases of leukemia and lymphoma in humans.

DCE is an organic liquid utilized in the manufacturing of adhesives, refrigerants, food packaging and synthetic fibers. DCE vapor is utilized in combination with other compounds as an anesthetic. According to the EPA, short term exposure to DCE at concentrations above the MCL can cause liver damage. Kidney damage, cancer and complications with pregnancy have been reported in cases with longer periods of exposure.



## CHAPTER THREE – PROPERTIES, SOURCES AND HEALTH RISKS OF CONTAMINANTS

### FEASIBILITY STUDY FOR THE MULTI-AGENCY REGIONAL GROUNDWATER RECOVERY PROJECT-100% DRAFT

Nitrates affect humans by combining with bacteria in the stomach forming Nitrite. According to the CDPH, nitrite oxidizes the iron in the blood rendering it incapable of carrying oxygen, producing a condition known as methemoglobinemia. This lack of oxygen can lead to death. Infants are extremely vulnerable to these affects as their bodies do not have the strong acids required to prevent the nitrate-reducing bacteria from forming.



FEASIBILITY STUDY FOR THE MULTI-AGENCY REGIONAL GROUNDWATER RECOVERY  
PROJECT-100% DRAFT

Chapter 4 – Treatment Processes

4.1 Treatment Overview

The treatment of the groundwater considered in this study provides a unique challenge because the effluent must be treated for multiple constituents. Although some treatment processes may appear similar, each is typically designed to target a specific contaminant. As a result, the treatment plant will most likely consist of a series of treatment processes, one for each contaminant to be removed. The following sections provide insight into the various available treatment processes for the contaminants of interest in this study: VOCs, perchlorate and nitrate. Certain processes are effective at removing more than one contaminant. To determine a feasible treatment process for each of the contaminants, the following impact parameters were evaluated for each treatment process:

- ◆ **Treatment Effectiveness** measures the effectiveness of the treatment process at removing the contaminants. A point value was assigned based upon a high, medium or low impact. A highly effective treatment process is one that removes 97-100% of the contaminant.
- ◆ **Capital Costs** measures the initial costs associated with implementation of a particular treatment process within the treatment facility. A point value was assigned based upon a high, medium or low initial capital cost.
- ◆ **Operations and Maintenance Costs** measures the costs associated with year to year operations of the treatment processes. A point value was assigned based upon a high, medium or low cost. The O&M costs were based upon a dollar per acre-foot value.
- ◆ **Regulatory Acceptance** attempts to measure the acceptance of the treatment process by the CDPH based upon existing statutes. A point value was assigned based upon “yes” accepted, “no” not accepted or no statutes exist yet.
- ◆ **Volume of Liquid Waste Generated** measures the amount of liquid waste generated by the treatment process. This is typically associated with water that is lost during treatment. A point value was assigned based upon a high, medium or low volume generated. A low volume generated is a process that loses no more than 1-2% of the water as it is treated.
- ◆ **Volume of Solid Waste Generated** measures the amount of solid waste generated by the treatment process. This is typically associated with the disposal of the various media or filters required. A point value was assigned based upon a high, medium or low volume generated.
- ◆ **Treatment Footprint** measures the amount of open space required for the vessels of each process. A point value assigned based upon a large, medium or small footprint requirement.

**FEASIBILITY STUDY FOR THE MULTI-AGENCY REGIONAL GROUNDWATER RECOVERY PROJECT-100% DRAFT**

**4.2 Particulate Removal**

Particulates in well water discharge are mainly naturally occurring solids located within the well casing. These solids are typically fine sands, clays and silts with a particle size of less than 75 µm (microns); other particulates include rust flakes or mortar coatings from the water pipes, organic matter and other small particles associated with water production. These particulates affect the performance of the treatment processes and will require removal prior to entering the facility. The particulate removal systems examined here are the cartridge filter system and the bag filter system.

*Cartridge Filter System*

**Figure 4-1: Cartridge Filter**



Filtration of well water can be done using either cartridge or bag filter system. Both can sufficiently filter water to a level appropriate for treatment prior to entering the treatment facility. The cartridge filtration system consists of a vessel constructed of carbon steel with a National Sanitation Foundation (NSF) certified two part epoxy internal coating. The filter vessels are each equipped with a davit assisted cover lift for access to the cartridges. Each vessel is comprised of a polypropylene pleated filter cartridge rated at 10 micron. Cartridge filters are designed to be one-time use only systems and require disposal of the filter. In addition, the ridged design of the filters typically requires an access platform to be constructed to allow for removal of the filters. Figure 4-1 is an example of the cartridges filters, Figure 4-2 is an example of the vessels required and Table 4-1 is the evaluation of the treatment process based upon the designated impact parameters.

**Figure 4-2: Multi-Cartridge Filter Vessel**





**FEASIBILITY STUDY FOR THE MULTI-AGENCY REGIONAL GROUNDWATER RECOVERY PROJECT-100% DRAFT**

**Table 4-1: Impact Evaluation for Determining Feasibility of Cartridge Filter Systems**

Impact	Evaluation	Point Value
Treatment Effectiveness	High	3
Capital Costs	High	3
O&M Costs	Medium	2
Regulatory Acceptance	Yes	3
Volume of Liquid Waste Generated	Low	3
Volume of Solid Waste Generated	Medium	2
Treatment Footprint	Medium	2

**Bag Filter System**

**Figure 4-3: Bag Filters**



A bag filtration system consists of a vessel constructed of carbon steel with epoxy internal coating or stainless steel. Each of the vessels contains a polypropylene felt bag rated at 10 micron. Bag filters can be removed, cleaned and reused, and bag filter systems do not require an access platform for filter removal. Lastly, bag filters trap all the particulates within the bag itself, thereby reducing the possibility of contamination during removal. Figure 4-3 is an example of the bag filters, Figure 4-4 is an example of the vessels required and Table 4-2 is the evaluation of the treatment process based upon the designated impact parameters.

A bag filtration system consists of a vessel constructed of carbon steel with epoxy internal coating or stainless steel. Each of the vessels contains a polypropylene felt bag rated at 10 micron. Bag filters can be removed, cleaned and reused, and bag filter systems do not require an access platform for filter removal. Lastly, bag filters trap all the particulates within the bag itself, thereby reducing the possibility of contamination during removal.

**Figure 4-4: Bag Filter Vessel**



**FEASIBILITY STUDY FOR THE MULTI-AGENCY REGIONAL GROUNDWATER RECOVERY PROJECT-100% DRAFT**

**Table 4-2: Impact Evaluation for Determining Feasibility of Bag Filter Systems**

Impact	Evaluation	Point Value
Treatment Effectiveness	High	3
Capital Costs	High	3
O&M Costs	Medium	2
Regulatory Acceptance	Yes	3
Volume of Liquid Waste Generated	Low	3
Volume of Solid Waste Generated	High	1
Treatment Footprint	Medium	2

**4.3 VOC Removal**

The systems examined for VOC removal include granular activated carbon treatment (GAC), air stripping, ultraviolet oxidation and biological treatment. Of these processes, ultraviolet oxidation and biological treatment are capable of removing multiple contaminants. Removal of multiple contaminants is dealt with in Section 4.6. Following are descriptions and evaluations of GAC and air stripping which specifically target VOCs.

***Granular Activated Carbon Treatment***

**Figure 4-5: Example of Activated Carbon**



Granular activated carbon treatment (GAC) is a physical adsorption process. Physical adsorption occurs when molecules exert attractive forces on each other, similar to a magnet, especially molecules on the surfaces of solids. The molecules of the VOCs have stronger attractive forces with the porous surface of the GAC filters than they do to the forces that keep them dissolved in water. For a GAC filter to adsorb the VOCs effectively the surface area of the carbon molecules within the filter needs to be increased; this is achieved through a process called activation. Activation is achieved by

heating the filter carbon in a controlled atmosphere. This heating process decomposes the carbon creating a large network of pores where the contaminants are attracted and collected thereby removing them from the water. Once activation is complete, the surface area of the carbon is increased substantially, to the point where one pound is equivalent to approximately 30,000 square yards. Once the GAC filters have reached their capacity for adsorbing the contaminants, they are removed from the vessels and replaced or recharged. Recharging occurs in high temperature furnaces, similar to the ones utilized for the process of activating the carbon, whereby the VOCs are vaporized

**FEASIBILITY STUDY FOR THE MULTI-AGENCY REGIONAL GROUNDWATER RECOVERY PROJECT-100% DRAFT**

while the pore structures are restored to new or nearly new quality. Figure 4-5 shows the GAC medium. Figure 4-6 shows a series of GAC vessels. Typically, GAC vessels are deployed in a lead-lag fashion in order to provide treatment assurance in the case of contaminant breakthrough of the lead vessel.

**Figure 4-6: Example of GAC Vessels**



***Air Stripping VOC Treatment***

By their nature, VOCs volatilize readily in air. Air stripping is a process by which VOCs are removed through a physical transfer from the contaminated water to the air. Air stripping usually occurs in a tower-like structure that is packed with a series of spherical plastic beads.

**Figure 4-7: Air Stripping Packs**



The contaminated water enters the tower near the top and is distributed over the beads evenly; as the water flows down air is forced up through the tower via a blower unit. The air passes over the submerged beads transferring the VOCs from the water to the air. The air containing the VOCs is then discharged through an exhaust pipe near the top of the tower. Since this air is now contaminated with hazardous air pollutants, a form of emissions control will be required; this is achieved by passing the air through a series of carbon filters. These air stripping towers vary in height and diameter based upon the flow rate. The bead packing within the tower

is typically done in stages with passive water redistributors between the bead sections. The most common problem with air stripping towers is the fouling of the packing. Specifically, the beads can adsorb some of the hardness properties of the water, causing calcification, rendering them incapable of distributing the water. Eventually, spent beads will need to be removed and replaced with a fresh set. The removal process typically destroys the existing beads which become attached to each other through calcification; therefore, rehabilitation of the beads for future use is not feasible. Figure 4-

**Figure 4-8: Air Stripping Towers**





**FEASIBILITY STUDY FOR THE MULTI-AGENCY REGIONAL GROUNDWATER RECOVERY PROJECT-100% DRAFT**

7 shows examples of spherical plastic beads of various diameters. Figure 4-8 shows a set of air stripping towers at a treatment plant. An evaluation of the impact parameters for the treatment technologies evaluated for VOC removal is presented in Table 4-3.

**Table 4-3: Impact Evaluation for Determining Feasibility VOC Removal System**

<b>Treatment Effectiveness Parameter</b>		
Process	Impact Value	Rating
GAC	High	3
Air Stripping	High	3
<b>Capital Costs Parameter</b>		
GAC	Medium	2
Air Stripping	Medium	2
<b>O&amp;M Costs Parameter</b>		
GAC	High	1
Air Stripping	High	1
<b>Regulatory Acceptance Parameter</b>		
GAC	Yes	3
Air Stripping	Yes	3
<b>Volume of Liquid Waste Parameter</b>		
GAC	Low	3
Air Stripping	Low	3
<b>Volume of Solid Waste Parameter</b>		
GAC	Medium	2
Air Stripping	High	1
<b>Treatment Footprint Parameter</b>		
GAC	High	1
Air Stripping	High	1

**4.4 Perchlorate Removal**

The systems examined for perchlorate removal include perchlorate ion exchange treatment, reverse osmosis and biological treatment. Of these processes, reverse osmosis and biological treatment are capable of removing multiple contaminants. Removal of multiple contaminants is dealt with in Section 4.6. Following is a description and evaluation of perchlorate ion exchange treatment which specifically targets perchlorate.

**FEASIBILITY STUDY FOR THE MULTI-AGENCY REGIONAL GROUNDWATER RECOVERY PROJECT-100% DRAFT**

***Perchlorate Ion Exchange Treatment***

**Figure 4-9: Example of Ion Exchange Resin**



Perchlorate ion exchange is a chemical process through which the harmful perchlorate ion ( $\text{ClO}_4^-$ ) is exchanged with another ion, typically chloride. Ion exchange is a process where the contaminated water passes through a bed of positively charged synthetic bead-like polymers; these beads typically contain the chloride ion. As the water passes through the beds, the positively charged selective beads attract the perchlorate ion to their surface to exchange with the chloride ion. Since the perchlorate ion is weakly hydrated in water, it

tends to have a high affinity to the beads. This high affinity allows the perchlorate to bond with greater efficiency thereby resulting in nearly complete removal of perchlorate from the contaminated water. Once the media has reached its capacity for adsorption of perchlorate, the vessel is removed from service and the media is replaced. The spent media can be recharged and placed back in service; however, at a diminished capacity. In most cases, the spent media is simply disposed of through incineration. Figure 4-9 shows an example of the ion exchange media. Figure 4-10 shows a pair of vessels utilized in the perchlorate ion exchange treatment process. An evaluation of the impact parameters for the perchlorate ion exchange treatment process is presented in Table 4-4.

**Figure 4-10: Vessels Utilized in the Perchlorate Ion Exchange Treatment Process**



**Table 4-4: Impact Evaluation and Point Value for Determining Feasibility of Perchlorate Ion Exchange Treatment**

Impact	Evaluation	Point Value
Treatment Effectiveness	High	3
Capital Costs	Medium	2
O&M Costs	Medium	2
Regulatory Acceptance	Yes	3
Volume of Liquid Waste Generated	Medium	2
Volume of Solid Waste Generated	High	1
Treatment Footprint	Medium	2



**FEASIBILITY STUDY FOR THE MULTI-AGENCY REGIONAL GROUNDWATER RECOVERY PROJECT-100% DRAFT**

**4.5 Nitrate Removal**

The systems examined for nitrate removal include nitrate ion exchange treatment, reverse osmosis and biological treatment. Of these processes, reverse osmosis and biological treatment are capable of removing multiple contaminants. Removal of multiple contaminants is dealt with in Section 4.6. Following is a description and evaluation of nitrate ion exchange treatment.

***Nitrate Ion Exchange Treatment***

Nitrate ion exchange is a chemical process through which the harmful nitrate ion (NO<sub>3</sub><sup>-</sup>) is exchanged with a chloride ion. The primary reaction that occurs in the ion exchange process can be described with the following equation:



The resins within these vessels are nitrate selective, meaning the nitrate ion will have a greater affinity to the beads. The media within the nitrate removal vessels can be regenerated on site with a brine solution. The brine solution, usually sodium chloride (NaCl), is backed washed into the media bed; the nitrate ion will exchange with the chloride ion on forming sodium nitrate. After the regeneration process, this sodium nitrate solution will need to be properly disposed of in an industrial waste sewer system. An evaluation of the impact parameters for the nitrate ion exchange treatment process is presented in Table 4-5.

**Table 4-5: Impact Evaluation and Point Value for Determining Feasibility of Nitrate Ion Exchange Treatment**

Impact	Evaluation	Point Value
Treatment Effectiveness	High	3
Capital Costs	Medium	2
O&M Costs	Medium	2
Regulatory Acceptance	Yes	3
Volume of Liquid Waste Generated	Medium	2
Volume of Solid Waste Generated	Low	3
Treatment Footprint	Medium	2

**4.6 Removal of Multiple Contaminants**

Reverse osmosis and biological treatment are capable of removing multiple contaminants. Following are descriptions and evaluations of these processes focusing on their capacity to remove each targeted contaminant.



**FEASIBILITY STUDY FOR THE MULTI-AGENCY REGIONAL GROUNDWATER RECOVERY  
PROJECT-100% DRAFT**

***Reverse Osmosis***

Reverse osmosis (RO), in combination with a carbon filter, is a treatment method where a semi-permeable membrane provides a barrier for contaminants. Osmosis is the process in which a liquid solvent passes from a dilute solution across a semi-permeable membrane to a more concentrated solution. In reverse osmosis, an external pressure greater than the osmotic pressure forces the solution across the membrane in the opposite direction. As the liquid passes the membrane it becomes more dilute as the contaminants are filtered out by the membrane. The RO method is mainly utilized to reduce concentrations of nitrates but can also reduce concentrations of perchlorates, uranium, and gross alpha. RO units have a limited capacity to reduce VOC concentrations, as well; however, this capacity is typically insufficient to reduce the VOC concentrations to below the MCL. RO is typically not considered a feasible treatment solution for nitrate and perchlorate removal as only 65 to 70 percent of the water is treated to drinking water standards. The remaining water is too highly concentrated with contaminants and is ultimately wasted.

***Biological Treatment***

In the biological treatment process, biological agents (bacteria) are introduced to break down certain contaminants into less harmful compounds. Once rendered harmless, the compounds are removed as a sludge-like mass which poses no public health concern. The biological treatment process is more widely utilized in wastewater treatment due to the high concentrations of organic compounds associated with wastewater; however, it is also a viable process in groundwater treatment. Biological treatment has been found to reduce VOC, perchlorate and nitrate concentrations in groundwater. Recently, experimentation conducted at the University of California, Riverside (Herman and Franken Berger, 1998, 1999) has determined a specific strain of bacteria can be utilized to breakdown, and in most cases completely remove, perchlorate. During these experiments it was observed perchlorate had been transformed into chloride at a rate of 97-100% of the volume added as perchlorate. This rate of transformation indicates that perchlorate can be completely destroyed unlike concentrating them in a resin which is common in ion exchange processes. In addition, the bacterium utilized in perchlorate reduction requires nitrates for growth thereby reducing nitrate to nitrogen gas as a byproduct of colony growth.



**FEASIBILITY STUDY FOR THE MULTI-AGENCY REGIONAL GROUNDWATER RECOVERY PROJECT-100% DRAFT**

An evaluation of the impact parameters for the removal of multiple contaminants is presented in Table 4-6.

**Table 4-6: Impact Evaluation and Point Value for Determining Feasibility of Multiple Contaminant Treatment**

<b>Treatment Effectiveness Parameter</b>			
<b>Contaminant</b>	<b>Process</b>	<b>Impact Value</b>	<b>Rating</b>
VOCs	RO	Low	1
	Biological	Medium	2
Perchlorate	RO	Medium	2
	Biological	Medium	2
Nitrate	RO	High	3
	Biological	Medium	2
<b>Capital Costs</b>			
GAC		High	1
Air Stripping		Medium	2
<b>Operations and Maintenance Costs</b>			
GAC		Medium	2
Air Stripping		Medium	2
<b>Regulatory Acceptance</b>			
GAC		Yes	3
Air Stripping		No Statutes Exist	2
<b>Volume of Liquid Waste Generated</b>			
GAC		High	1
Air Stripping		Low	3
<b>Volume of Solid Waste Generated</b>			
GAC		Medium	2
Air Stripping		Medium	2
<b>Treatment Footprint</b>			
GAC		High	1
Air Stripping		High	1

**4.7 Comparisons between Treatment Systems**

To determine the most feasible form treatment for each of the contaminants, the ratings associated with each of the impacts (chapter 4.1) are organized into a decision table. The table will utilize the following values to quantitatively determine the most feasible treatment process:

**Weight Value** – Each parameter considered carries a different degree of importance in the evaluation process. The Weight Value is a multiplier that quantifies the relative





**FEASIBILITY STUDY FOR THE MULTI-AGENCY REGIONAL GROUNDWATER RECOVERY PROJECT-100% DRAFT**

importance of each parameter considered in the evaluation. The more important a parameter is in evaluating a treatment process, the higher its weighted value.

**Rating or Impact** – For each treatment process, every parameter is assigned a rating or impact value between one and three. This value quantifies the relative impact a particular alignment poses on a given parameter. The higher the number the greater the impact it has (more attractive).

**Totals** – The summation of the products of the *weight value* and *rating or impact* for each treatment process. The higher the number the more attractive the process is for treatment of the contaminants.

Tables 4-7 to 4-10 shows the evaluations of each individual treatment process.

**Table 4-7: Evaluation of Particulate Treatment Process**

Type of Impact	Weight Value	Cartridge		Bag	
		Impact Value	Total	Impact Value	Total
Treatment Effectiveness	3	3	9	3	9
Capital Costs	3	3	9	3	9
O&M Costs	3	2	6	2	6
Regulatory acceptance	2	3	6	3	6
Volume of Liquid Waste Generated	2	3	6	3	6
Volume of Solid Waste Generated	2	2	4	1	2
Treatment Footprint	1	2	2	2	2
<b>TOTALS</b>			<b><u>42</u></b>		<b><u>40</u></b>
<b>LEGEND:</b> Weight Value 1 - Minimal Importance 2 - Important 3 - Very Important		<b>LEGEND:</b> Rating or Impact 1 - Low 2 - Medium 3 - High			





CHAPTER FOUR – TREATMENT PROCESSES

FEASIBILITY STUDY FOR THE MULTI-AGENCY REGIONAL GROUNDWATER RECOVERY PROJECT-100% DRAFT

Table 4-8: Evaluation of VOC Treatment Processes

Type of Impact	Weight Value	GAC		Air Strippers		RO/Carbon Filter		Biological	
		Impact Value	Total	Impact Value	Total	Impact Value	Total	Impact Value	Total
Treatment Effectiveness	3	3	9	3	9	1	3	2	6
Capital Costs	3	2	6	2	6	1	3	2	6
O&M Costs	3	1	3	1	3	2	6	2	6
Regulatory Acceptance	2	3	6	3	6	3	6	2	4
Volume of Liquid Waste Generated	2	3	6	3	6	1	2	3	6
Volume of Solid Waste Generated	2	2	4	1	2	2	4	2	4
Treatment Footprint	1	1	1	1	1	1	1	1	1
<b>TOTALS</b>			<b>35</b>		<b>33</b>		<b>25</b>		<b>33</b>

**LEGEND:**  
 Weight Value  
 1 - Minimal Importance  
 2 - Important  
 3 - Very Important

**LEGEND:**  
 Rating or Impact  
 1 - Low  
 2 - Medium  
 3 - High



CHAPTER FOUR – TREATMENT PROCESSES

FEASIBILITY STUDY FOR THE MULTI-AGENCY REGIONAL GROUNDWATER RECOVERY PROJECT-100% DRAFT

Table 4-9: Evaluation of Perchlorate Treatment Processes

Type of Impact	Weight Value	Ion Exchange		Biological		RO	
		Impact Value	Total	Impact Value	Total	Impact Value	Total
Treatment Effectiveness	3	3	9	2	6	2	6
Capital Costs	3	2	6	2	6	1	3
O&M Costs	3	2	6	2	6	2	6
Regulatory acceptance	2	3	6	2	4	3	6
Volume of Liquid Waste Generated	2	2	4	3	6	1	2
Volume of Solid Waste Generated	2	1	2	2	4	2	4
Treatment Footprint	1	2	2	1	1	1	1
<b>TOTALS</b>			<b>35</b>		<b>33</b>		<b>28</b>
<b>LEGEND:</b> Weight Value 1 - Minimal Importance 2 - Important 3 - Very Important		<b>LEGEND:</b> Rating or Impact 1 - Low 2 - Medium 3 - High					



FEASIBILITY STUDY FOR THE MULTI-AGENCY REGIONAL GROUNDWATER RECOVERY PROJECT-100% DRAFT

Table 4-10: Evaluation of Nitrate Treatment Processes

Type of Impact	Weight Value	Ion Exchange		Biological		RO	
		Impact Value	Total	Impact Value	Total	Impact Value	Total
Treatment Effectiveness	3	3	9	2	6	3	9
Capital Costs	3	2	6	2	6	1	3
O&M Costs	3	2	6	2	6	2	6
Regulatory acceptance	2	3	6	2	4	3	6
Volume of Liquid Waste Generated	2	2	4	3	6	1	2
Volume of Solid Waste Generated	2	3	6	2	4	2	4
Treatment Footprint	1	2	2	1	1	1	1
<b>TOTALS</b>			<b>39</b>		<b>33</b>		<b>31</b>
<b>LEGEND:</b> Weight Value 1 - Minimal Importance 2 - Important 3 - Very Important		<b>LEGEND:</b> Rating or Impact 1 - Low 2 - Medium 3 - High					

**Conclusions of Treatment Processes Evaluation**

The Cartridge Filter is the preferred particulate removal system. The Cartridge Filter and the Bag Filter were comparable for every evaluation parameter except in *Volume of Solid Waste Generated* where the Cartridge Filter provides a slight advantage.

GAC Treatment is the preferred VOC removal process. The evaluation concluded that GAC Treatment and Air Stripping were equal. To determine the preferred VOC removal process, additional parameters were examined. Air stripping towers are tall and noisy. This may complicate the *Aesthetics* and *Noise* factors of a CEQA application.





**FEASIBILITY STUDY FOR THE MULTI-AGENCY REGIONAL GROUNDWATER RECOVERY  
PROJECT-100% DRAFT**

Furthermore, the Air Stripping process occurs at atmospheric pressure which means any water pressure above atmospheric entering the treatment plant from the collection system would be lost. Since other treatment processes (notably perchlorate and nitrate removal) will follow VOC removal, a supplemental pumping system would have to be added within the treatment plant to power those processes. The supplemental pumping system represents an ancillary cost to the Air Stripping option. Due to the potential CEQA issues and inherent hydraulic issues, Air Stripping is a less attractive alternative to GAC Treatment.

Perchlorate Ion Exchange Treatment is the preferred perchlorate removal process. Ion exchange provides numerous advantages over Biological Treatment and Reverse Osmosis as shown in the evaluation.

Nitrate Ion Exchange Treatment is the preferred nitrate removal process. Similar to perchlorate removal, ion exchange provides numerous advantages over Biological Treatment and Reverse Osmosis for the removal of nitrate.

***Order of Preferred Treatment Processes***

Particulate removal is the first process and serves to protect sensitive equipment and media from damage associated with silt, sand and clay produced from the wells. The order of the remaining processes is dependent on chemistry. Experience with similar plants indicates the order of the remaining processes will be perchlorate removal, followed by VOC removal, followed by nitrate removal pending confirmation by the equipment and media vendors. Consideration of the use of filtration between each unit process may be required to ensure fines from media do not transfer from one process to the other.

**4.8 Waste Discharge Requirements**

Certain water treatment processes produce highly concentrated liquid waste as the contaminants are removed. The disposal of the waste products only pertains to the ion exchange treatment or GAC adsorption processes, as the Biological and UV Oxidation treatments completely destroy the contaminants on site. This waste must be disposed of properly. Some of the process media can be recharged and reused on site, while others must be removed and either recharged by licensed professionals or disposed of properly off site.

Both the GAC filters and Perchlorate Ion Exchange Treatment processes require the media to be removed from the facility. The carbon in the GAC filters can be reactivated by repeating the heating process, described in Section 4.3; and, the Perchlorate Ion Exchange resin can be recharged at a certified facility. These facilities are typically operated by the filters or resin manufacture.



**FEASIBILITY STUDY FOR THE MULTI-AGENCY REGIONAL GROUNDWATER RECOVERY  
PROJECT-100% DRAFT**

The nitrate treatment vessels can be recharged on site with a brine solution. This solution may be discharged to an industrial waste sewer. For this treatment plant, the nearest sewer that is capable of handling the waste brine solution is in Irwindale Avenue; therefore, a brine pipeline will be required in Gladstone Street between the plant and the sewer connection point in Irwindale Avenue.

**4.9 Site Considerations**

A site will be required to house equipment associated with the treatment processes and distribution booster pumping station. Issues of concern in the site selection process include providing sufficient area to accommodate the various treatment processes and booster pumping equipment, adequate access to treatment vessels for the disposal and replacement of resins and other media and proximity to the affected wells. In addition to these logistical and pragmatic constraints, the viability of a site must include accommodation of CEQA requirements and any local requirements, restrictions or constraints. As discussed in Section 2.5, CEQA may require a study to determine the impact on the following environmental factors: aesthetics, biological resources, air quality, hazardous materials, cultural resources, hydrology and water quality, noise, geology and soils, land use and planning, transportation and traffic, and mandatory findings of significance.

Based on *Civiltec*'s experience designing similar facilities and assuming that three separate processes are required to remove the three contaminants of interest (VOC's, nitrate and perchlorate), the minimum viable area required to accommodate the treatment plant is estimated at 1.5 acres.

Ten sites were considered as potential locations for the proposed treatment plant and pump station. One or more of these sites may be required to meet the needs of this project. The sites are located throughout Azusa with the majority of them located in close proximity to the wells. Table 4-11 lists the sites; Figure 4-11 provides an overview of the site locations.

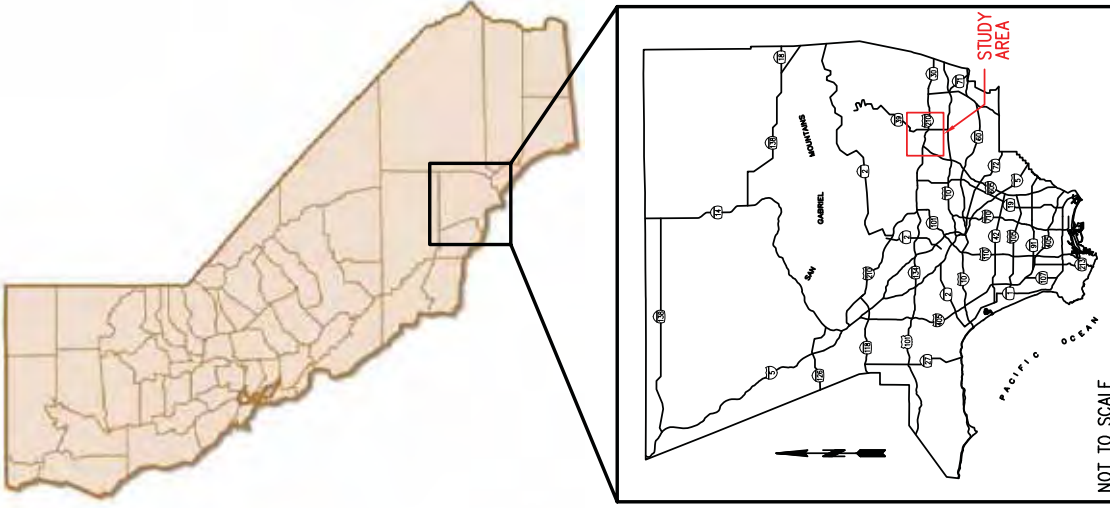

NOT TO SCALE



NOT TO SCALE

					<p>PREPARED BY:</p>  <p><i>CIVILTEC</i> engineering inc.</p> <p>General Civil, Municipal, Water and Wastewater Engineering, Management and Surveying 118 West Lima Avenue Monrovia, CA 91016 Phone: (626) 337-6588 Fax: (626) 337-2957</p>	<p>FIGURE</p>
						<p>MULTI-AGENCY REGIONAL GROUND WATER RECOVERY PROJECT</p>

**FEASIBILITY STUDY FOR THE MULTI-AGENCY REGIONAL GROUNDWATER RECOVERY PROJECT-100% DRAFT**

**Table 4-11: Sites Considered As Potential Locations For The Proposed Treatment Plant And Pump Station.**

Site #	Area (acres)	Location
1	3.16	17511 E Arrow Highway
2	4.04	701 S. Azusa Avenue
3	2.76	17018 E. Gladstone Street
4	0.61	5500 N. Lark Ellen Avenue
5	26.75	822 S Cerritos Avenue
6	0.70	220 N. Aspan Avenue
7	8.45	201 N. Vernon Avenue
8	2.29	120 N Aspan Avenue
9	1.53	901 W 1 <sup>st</sup> Street
10	1.83	16734 E Arrow Highway

**4.9.1: Site 1**

Site 1 is located in the vicinity of 17511 E. Arrow Highway. It is a 3.16 acre open lot currently owned by Azusa Redevelopment, a division of Azusa Economic and Development Department.

**Figure 4-12: Aerial Photo of Site 1**





**FEASIBILITY STUDY FOR THE MULTI-AGENCY REGIONAL GROUNDWATER RECOVERY PROJECT-100% DRAFT**

**Advantages**

- ◆ Large open lot with no existing structures to demolish
- ◆ Access available from two main streets: Azusa Avenue and Arrow Highway
- ◆ Bounded by the Big Dalton wash on the southeasterly corner of the lot providing easy access for ‘pump to waste’ during plant testing and start up operations

**Disadvantages**

- ◆ Currently owned by Azusa Redevelopment; fee title or a lease agreement will be required before development of the treatment plant can commence
- ◆ Approximately ½ mile from the nearest wells; additional piping and underground infrastructure is required for raw water collection system

**4.9.2: Site 2**

Site 2 is located in the vicinity of 701 S. Azusa Avenue. It is a 4.04 acre open lot currently owned by a private development company. The site is currently zoned as single-family residential.

**Figure 4-13: Aerial Photo of Site 2**





**FEASIBILITY STUDY FOR THE MULTI-AGENCY REGIONAL GROUNDWATER RECOVERY  
PROJECT-100% DRAFT**

**Advantages**

- Large open lot with no existing structures to demolish

**Disadvantages**

- Currently owned by a private development company; fee title will be required before development of the treatment plant can commence
- Currently zoned for residential use, request for industrial use rezoning required
- Approximately  $\frac{3}{4}$  mile from nearest well; additional piping and underground infrastructure is required for raw water collection system
- Limited access to site: currently only available from south bound Azusa Avenue

**4.9.3: Site 3**

Site 3 is located in the vicinity of 17018 E. Gladstone Street. It has an area of 2.76 acres and is owned by the Azusa Valley Water Company. Azusa Wells 9 and 10 are located at this site.

FEASIBILITY STUDY FOR THE MULTI-AGENCY REGIONAL GROUNDWATER RECOVERY PROJECT-100% DRAFT

Figure 4-14: Aerial Photo of Site 3



**FEASIBILITY STUDY FOR THE MULTI-AGENCY REGIONAL GROUNDWATER RECOVERY PROJECT-100% DRAFT**

**Advantages**

- ◆ Azusa Wells 9 and 10 are located on site
- ◆ Central location to majority of the wells
- ◆ Currently owned by Azusa Valley Water Company; therefore a transfer of fee title to the group is feasible. Lease of the site may also be considered viable.
- ◆ Bounded by the Big Dalton wash on the southerly portion of the lot providing easy access for ‘pump to waste’ operations during plant testing and start up operations

**Disadvantages**

- ◆ Limited access to site, currently only available from Gladstone Street

**4.9.4: Site 4**

Site 4 is in the vicinity of 5500 N. Lark Ellen Avenue. It has an area of 0.61 acres and is owned by the Covina Irrigating Company. The Contract Well is located at this site.

**Figure 4-15: Aerial Photo of Site 4**





**FEASIBILITY STUDY FOR THE MULTI-AGENCY REGIONAL GROUNDWATER RECOVERY  
PROJECT-100% DRAFT**

**Advantages**

- ◆ CICO Contract well is located on site
- ◆ Central location to majority of the wells
- ◆ Currently owned by CICO: transferring fee title to the group is feasible or a lease may be considered.
- ◆ Bounded by the Big Dalton wash on the northerly portion of the lot providing easy access for ‘pump to waste’ during plant testing and start operations

**Disadvantages**

- ◆ Site area is too small for development of the entire treatment plant: site would most likely be used in conjunction with Site 3
- ◆ Limited access to site, currently only available from Lark Ellen Avenue

**4.9.5: Site 5**

Site 5 is located in the vicinity of 822 S Cerritos Avenue. It has an area of 26.75 acres and is owned by the Los Angeles County Flood Control District who uses it as a spreading field.

FEASIBILITY STUDY FOR THE MULTI-AGENCY REGIONAL GROUNDWATER RECOVERY  
PROJECT-100% DRAFT

Figure 4-16: Aerial Photo of Site 5



**Advantages**

- ◆ Large open lot with no existing structures to demolish
- ◆ Access to the site is from a service road parallel to the Big Dalton Wash; this service road can be accessed from two separate main streets, Citrus Avenue and Cerritos Avenue
- ◆ Bounded by the Big Dalton wash on the northerly portion of the lot providing easy access for ‘pump to waste’ during plant testing and start up operations

**FEASIBILITY STUDY FOR THE MULTI-AGENCY REGIONAL GROUNDWATER RECOVERY PROJECT-100% DRAFT**

**Disadvantages**

- ◆ Currently owned by the Los Angeles County Flood Control District as a detention basin; therefore it is unavailable for development.
- ◆ Currently used as a depressed spreading ground: extensive fill required to bring to grade with surround service road
- ◆ Approximately 1.5 miles from nearest well: additional piping and underground infrastructure is required for raw water collection system

**4.9.6: Site 6**

Site 6 is located in the vicinity of 220 N. Aspan Avenue. It has an area of 0.70 acres and is owned by ALW. The Aspan Well is located at this site.

**Figure 4-17: Aerial Photo of Site 6**



**Advantages**

- ◆ Lot currently owned by ALW: transfer of fee title to the group feasible
- ◆ Existing reservoir on site suitable for storage/equalization
- ◆ Aspan Well is located on site

**Disadvantages**

- ◆ Site area is too small for development of the entire treatment plant: site would most likely be used in conjunction with Site 7

**FEASIBILITY STUDY FOR THE MULTI-AGENCY REGIONAL GROUNDWATER RECOVERY PROJECT-100% DRAFT**

- ◆ This site is not a central location to the connections required for waste brine, WVWD/RWD distribution and the wells; therefore, additional piping and underground infrastructure is required for raw water collection system and discharge of potable water

**4.9.7: Site 7**

Site 7 is located in the vicinity of 201 N. Vernon Avenue. It has an area of 8.45 acres and is currently part of the Azusa Unified School District. Only a portion of this site is considered for development of the treatment plant.

**Figure 4-18: Aerial Photo of Site 7**



**Advantages**

- ◆ Large open lot with some structures: if sub-divided the structures would not become an issue for development
- ◆ Located near the Aspan Well



**FEASIBILITY STUDY FOR THE MULTI-AGENCY REGIONAL GROUNDWATER RECOVERY PROJECT-100% DRAFT**

- ◆ Access to the site can be achieved from either Virginia Avenue or through the Aspan Well site (Site 6)

**Disadvantages**

- ◆ Currently owned by the Azusa Unified School District and is utilized for an Elementary School; therefore, unavailable for development
- ◆ This site is not a central location to the connections required for waste brine, WVWD/RWD distribution and the wells; therefore, additional piping and underground infrastructure is required for raw water collection system and discharge of potable water

**4.9.8: Site 8**

Site 8 is located in the vicinity of 120 N. Aspan Avenue. It has an area of 2.29 acres and is owned by a private party.

**Figure 4-19: Aerial Photo of Site 8**





**FEASIBILITY STUDY FOR THE MULTI-AGENCY REGIONAL GROUNDWATER RECOVERY  
PROJECT-100% DRAFT**

**Advantages**

- Large open lot with some structures
- Located near the Aspan Well

**Disadvantages**

- This site is currently owned by a private party investor: fee title required prior to development of the treatment facility
- This site is not a central location to the connections required for waste brine, WVWD/RWD distribution and the wells; therefore, additional piping and underground infrastructure is required for raw water collection system and discharge of potable water
- Access limited to a driveway at the intersection of Duell Street and Barbara Avenue. This driveway location appears to be a previously demolished residence: access to this site would be situated between two existing residences

**4.9.9: Site 9**

Site 9 is located in the vicinity of 901 W. 1<sup>st</sup> Street. It has an area of 1.53 acres and is a vacant lot currently owned by a private party.

**FEASIBILITY STUDY FOR THE MULTI-AGENCY REGIONAL GROUNDWATER RECOVERY PROJECT-100% DRAFT**

**Figure 4-20: Aerial Photo of Site 9**



**Advantages**

- ◆ Open lot with no existing structures to demolish
- ◆ Located near the Aspan and Vosburg Wells

**Disadvantages**

- ◆ This site is currently owned by a private party investor: fee title required prior to development of the treatment facility
- ◆ This site is not a central location to the connections required for waste brine, WVWD/RWD distribution and the wells; therefore, additional piping and underground infrastructure is required for raw water collection system and discharge of potable water

**FEASIBILITY STUDY FOR THE MULTI-AGENCY REGIONAL GROUNDWATER RECOVERY PROJECT-100% DRAFT**

**4.9.10: Site 10**

Site 10 is located in the vicinity of 16734 W. Arrow Highway. It has an area of 1.83 acres and is owned by Glendora. Glendora Wells 3 and 4 are located at this site.

**Figure 4-21: Aerial Photo of Site 10**



**Advantages**

- ◆ Centralized location
- ◆ Glendora Wells 3 and 4 located on site
- ◆ Owned by Glendora: transfer of fee title to the group is feasible



**FEASIBILITY STUDY FOR THE MULTI-AGENCY REGIONAL GROUNDWATER RECOVERY  
PROJECT-100% DRAFT**

- Bounded by the Big Dalton wash on the easterly portion of the lot providing easy access for ‘pump to waste’ during plant testing and start up operations

**Disadvantages**

- Contains some structures and landscaping: demolition required before the site is available for development

***Site Evaluation Summary***

Through a process of elimination based upon the advantages and disadvantages for each of the sites considered the following conclusions were determined:

***Lot Area***

As previously stated earlier in this section the minimum lot area required for the treatment facility is 1.5 acres; therefore Site 4 and Site 6 are eliminated as feasible sites due to insufficient size.

***Beneficial Use***

Site 5 is currently owned by the Los Angeles County Flood Control District and used as a spreading ground for groundwater recharge. The use of Site 5 is more valuable as a spreading ground than a treatment facility since other sites are available. For this reason Site 5 is eliminated as a possibility.

Site 7 is currently owned by the Azusa Unified School district and utilized as a recreational field for an Elementary School. The use of Site 7 is more valuable to meet the open space requirement for public schools than as a treatment facility since other sites are available. For this reason Site 7 is eliminated as a possibility.

***Proximity***

There is a benefit inherent to the proximity of the site to the well field and the local industrial sewer. Being close to the well field minimizes the collection system infrastructure. Being close and of an adequate elevation differential to the industrial sewer will minimize the waste brine disposal infrastructure. Therefore Site 1, Site 2, Site 8 and Site 9 are eliminated as possibilities due to their distances from the respective existing groundwater production infrastructure and existing industrial sewer.

From these results it was determined Site 3 and Site 10 are possibilities for development of the treatment plant. Site 3 and Site 10 are both of sufficient size to accommodate the treatment facility. Site 10 is considered to have a slight advantage over Site 3 as it is

**FEASIBILITY STUDY FOR THE MULTI-AGENCY REGIONAL GROUNDWATER RECOVERY PROJECT-100% DRAFT**

more centralized to the well field, potential distribution connection points and the connection point for the waste brine discharge line. In addition, the current developments on Site 10, other than the existing wells and tank, are all temporary. Site 3 has some permanent structures that are currently being utilized as a restaurant; therefore, the beneficial use of Site 10 is greater as the temporary developments can be more easily removed. For the purposes of this report Site 10 is determined to be the best alternative; however, Site 3 is also a good alternate for future consideration.

**Figure 4-22: Site 10 Little Dalton Wash**



Site 10 is also bounded by the Little Dalton (See Figure 4-22 Site 10 Little Dalton Wash). Proximity to the wash at such a close distance will limit the need to construct drainage facilities to discharge start-up and general utilities waters from the operation of the treatment plant. This among the other reasons cited determine that Site 10 is considered to be a superior location

for the construction of the treatment facility. Site 10 is currently generally occupied by a small reservoir which may or may not be deemed to be usable during formal evaluations of the site. The small reservoir may be utilized to store utility water as appropriate for the final plan configuration. Also situated on the site are the well buildings and enclosures for Glendora Well Nos. 3 and 4. These facilities are generally in disrepair and could be demolished or abandoned if this site were developed. Site 10 is also currently occupied with a cellular tower in its farther north and each corner. In addition a portion of the site is being leased for housing a plant nursery. Nursery operations would need to be removed to develop the site.



**FEASIBILITY STUDY FOR THE MULTI-AGENCY REGIONAL GROUNDWATER RECOVERY  
PROJECT-100% DRAFT**

**Chapter 5 – Treatment Systems Case Studies**

**5.1 General Description**

This chapter provides an overview of the preferred treatment processes through a presentation of case studies and a description of equipment installed at local utilities.

**5.2 Case Studies**

**Ion Exchange for Perchlorate Removal**

La Puente Valley County Water District  
La Puente, California  
Calgon Carbon Corporation ISEP® Continuous Contactor

The Main San Gabriel Basin Watermaster (Watermaster) manages the drinking water supplies within the Main San Gabriel Basin, a 167 square mile basin area drained by the San Gabriel River. The basin is located east of Los Angeles, in Los Angeles County, California, and meets 80-90% of the valley's water demand, for over one million people. The Main San Gabriel Basin is designated as a Superfund site due to VOC contamination from use of industrial solvents and chemicals; four areas within the Basin are named as Superfund Sites. Perchlorate was discovered in groundwater in the Basin in May 1997, leading to the shutdown of eight public drinking water wells. Four of the wells were shutdown, groundwater from another two wells was "blended", and two wells were inactivated due to other contaminants.

A four-pronged approach was taken to fast-track development of a perchlorate treatment technology for the Main San Gabriel Basin. In October, 1997, the San Gabriel Perchlorate Coordinating Team was formed, and in June 1998 a screening study by California Polytechnical Institute, Pomona was sponsored. An ion exchange study by Montgomery Watson was sponsored in February 1999, and a joint study was undertaken with Calgon Carbon Corporation in October 1998. The San Gabriel Perchlorate Coordinating Team consists of local and regional water agencies, regional, state, and federal regulatory agencies, potentially responsible parties (PRPs), and highly-specialized technical consultants, and was formed to share information, pool research resources, and to fast-track the peer and regulatory review process. The screening study by California Polytechnical Institute investigated various biological, chemical, and physical treatment methods.



**FEASIBILITY STUDY FOR THE MULTI-AGENCY REGIONAL GROUNDWATER RECOVERY  
PROJECT-100% DRAFT**

The California Polytechnical Institute study made the following main conclusions for physical treatment:

- ◆ Ion exchange was the most promising treatment alternative
- ◆ The Calgon Carbon Corporation ISEP® (ion separation) treatment system resulted in low waste brine (<1%)
- ◆ Ion exchange technology is currently used in public drinking water systems
- ◆ Waste brine disposal may become a problem in the future

Montgomery Watson undertook bench-scale and pilot-scale tests of anion exchange technology, testing commercially available strong-base resins. Perchlorate concentrations in the bench-scale influent were 200 ug/L, and in the pilot-scale influent were 90 ug/L. Treated effluent perchlorate concentrations at both bench-scale and pilot-scale were not detectable. It was found that polyacrylic resins treated 725 bed volumes before breakthrough, and were then fully regenerated.

The Watermaster solicited engineers, contractors, suppliers, and manufacturers to participate in a joint venture, where the Watermaster would provide the site and source water, and the joint venture partner would provide a "black box" treatment plant. The only proposal for this joint venture that was accepted was that for the Calgon Carbon Corporation ISEP treatment process. The pilot testing was performed on the Big Dalton Well, Baldwin Park, California. The flow rate to the pilot ISEP system was 4.28 gpm; brine produced was 0.75% of the inflow. The influent perchlorate concentration of 18-76 ppb, was treated to an effluent concentration of <4 ppb. Based on these results, Calgon Carbon Corporation was retained to construct a full-scale ISEP treatment plant for the La Puente Valley County Water District. Construction was completed in March 2000, and the plant was tested from February 10 to March 12, 2000. Reliability and ease of operation were proven in subsequent, intermittent operations, and the waste brine produced is 0.85% of the inflow.

Calgon Carbon Corporation conducted the first laboratory tests of the ISEP system in January 1998. Calgon Carbon Corporation announced on December 7, 1998, that it had successfully completed field trials for the removal of perchlorate from groundwater in California's San Gabriel Valley utilizing an ISEP continuous ion exchange system which was designed and manufactured by Advanced Separation Technologies, a subsidiary of Calgon Carbon. The month-long trial, which was supported by the Main San Gabriel Basin Watermaster and conducted at the Big Dalton well site, demonstrated ISEP's capability to exceed requirements by reducing perchlorate concentration in the groundwater on a continuous, ongoing basis to below California's Provisional Action Level of 18 parts per billion (ppb).





**FEASIBILITY STUDY FOR THE MULTI-AGENCY REGIONAL GROUNDWATER RECOVERY  
PROJECT-100% DRAFT**

A summary of the results was presented to the Watermaster. The data show that the ISEP system exceeded requirements, consistently reducing perchlorate concentration in the groundwater from influent levels of 18-76 ppb to below the detection level limit of 4 ppb at a 4.28 gpm flow rate. The results also demonstrate that the ISEP reduced the concentration of nitrate in the groundwater by about 60%.

These results confirm the capability of the ISEP to reliably, consistently, and economically remove small amounts of perchlorate in contaminated water and to concurrently reduce the concentrations of other ionic contaminants such as nitrate and sulfate to insignificant levels. Calgon Carbon Corporation produces, supplies and designs products, services, and technologies for the purification, separation, and concentration of liquids and gases. Advanced Separation Technologies Incorporated, based in Lakeland, Florida, is a worldwide supplier of the patented ISEP Continuous Contactor for ion exchange, chromatography, and adsorption.

**Granular Activated Carbon for VOC Removal**

Green Valley Water Treatment Plant  
Suisun, California  
Orica Watercare MIEX® Treatment System

The Green Valley Water Treatment Plant (WTP) draws its water from two sources to supply Suisun, California and surrounding communities. The WTP's distribution system is very long resulting in lengthy detention times where free chlorine used for disinfection reacts with total organic carbon (TOC) to form high levels of Total Trihalomethanes (TTHMs). The Green Valley WTP was unable to adequately reduce the source water TOC levels to achieve compliance with the Environmental Protection Agency (EPA) TTHM regulations. An Orica Watercare MIEX® Treatment System was installed in January 2006 to reduce the treated water TOC level prior to disinfection. This resulted in over a 65% decrease in distribution system TTHM levels, allowing the Green Valley WTP to easily meet the EPA TTHM standard.

The Green Valley WTP, operated by the City of Vallejo, receives raw water from Lakes Frey and Madigan, and the Solano Irrigation District supplied from Lake Berryessa. The WTP's long distribution system includes a 9-mile long, 24-inch main that serves only 62 connections. As a result, distribution detention times range from two weeks to as long as four weeks, thus providing more time for the chlorine to react with TOC and form TTHMs. The plant's previous coagulation treatment using alum and a cationic polymer had little impact on treated water TOC levels for either water source. The WTP was therefore unable to reduce TTHMs to below the EPA standard.

The City of Vallejo considered several technologies to address the TTHM problem at the Green Valley WTP, including the MIEX® Process, Granular Activated Carbon (GAC)



**FEASIBILITY STUDY FOR THE MULTI-AGENCY REGIONAL GROUNDWATER RECOVERY  
PROJECT-100% DRAFT**

and enhanced coagulation. Based on capital and operating costs the net present worth of GAC was significantly higher than the alternatives. Enhanced coagulation was not effective in providing enough TOC removal to reduce TTHMs below the EPA standard. In May 2004, a MIEX® Pilot was conducted which indicated that TOC levels could be significantly reduced, providing a large comfort margin for the WTP to meet current and future EPA TTHM standards. As a result the City of Vallejo decided to install a 1 million gallon day (MGD) MIEX® treatment system as a pretreatment step to the existing treatment plant.

**Project Outcomes**

- ◆ Full-scale treatment results mirrored pilot trial results for TOC removal and Simulated Distribution System TTHM reductions.
- ◆ Treated water TOC levels have been reduced by 60 to 70%.
- ◆ System wide average TTHM levels have been reduced from 119 µg/L to 38 µg/L after MIEX® System start-up.
- ◆ Coagulants (alum and polymer) have been replaced by an ACH/polymer blend at less than 10% of the previous dose rate.
- ◆ Chlorine dose for disinfection has been reduced by 40%.
- ◆ Algae growth has been significantly reduced in downstream treatment processes.
- ◆ Chlorine residuals can now be achieved at the furthest points of the distribution system.

**5.3 Treatment Equipment Installed at Local Utilities**

Selective Ion Exchange and Granulated Activated Carbon are proven technologies for potable water treatment. These treatment processes are widely used in Southern California for removal of the same contaminants that affect the groundwater production of the wells cited in this study.

Table 5-1 provides a general summary of local treatment facilities and the equipment installed there. The information contained in Table 5-5 includes all treatment facilities in Southern California actively using ion exchange and GAC treatment processes in 2005, per DWR. As such, it does not necessarily represent a comprehensive list of current facilities.



CHAPTER FIVE – TREATMENT SYSTEM  
CASE STUDIES

FEASIBILITY STUDY FOR THE MULTI-AGENCY REGIONAL GROUNDWATER RECOVERY  
PROJECT-100% DRAFT

Table 5-1: Summary of Equipment Used in Local Installations

Equipment	Manufacturer	Product	System	Facility
Selective Ion Exchange Resin	Purolite	A-400E	Hi-Desert WD	Wells 12E and 17E
	Amberlite	PWA555	SCWC - San Dimas	Columbia Plant
	Purolite	A-400E	East Valley WD	Plant 132
	Calgon Carbon	CalRes 2000	La Puente CVWD	La Puente Treatment Plant
	Amberlite	PWA555	Southern California Water Company	South San Gabriel Trmt Plnt
	Calgon Carbon	CalRes 2101	California Domestic Water Company	Perchlorate Removal Facility
	Resin Tech	SIR-100-HP	City of Redlands	Rees Well IX
	Dow Chemical US Filter	DOWEX 1 USF A-284-NSF	City of Colton	Wells 15, 17 & 24 IX
	Purolite	A-850FL	City of Rialto	Chino Well 1
	US Filter	USF A-284-NSF	City of Rialto	Chino Well 2
	Amberlite	PWA2	West Valley WD	Well 18A
	Calgon Carbon	CalRes 2100	West Valley WD	Well 42
	Sybron	ASB2	Pomona, City of	
	Dow Chemical	DOWEX 1	Rialto, City of	
	Calgon Carbon	Calres 2103	Riverside, City of	Tippecanoe Regional Plant
	Calgon Carbon	Calres 2101	Riverside, City of	Sunnyside Regional Plant
	Calgon Carbon	Calres 2103	Riverside, City of	Gage 46-1 Plant
Calgon Carbon	CalRes 2000	San Gabriel WQA	Big Dalton Well	
Granulated Activated Carbon		GAC	City of Santa Monica	Production Aquifer Remediation System
		GAC	Glendale	Glendale OU
		GAC	Burbank	Burbank Operable Unit



**FEASIBILITY STUDY FOR THE MULTI-AGENCY REGIONAL GROUNDWATER RECOVERY  
PROJECT-100% DRAFT**

**Chapter 6 – Blending Analysis**

**6.1 General Overview**

Blending is a technique utilized to lower concentrations of contaminants below the MCL by combining waters of varying concentrations. In general, a source with a high contaminant concentration is combined with a source with no or very low contamination resulting in a mixture a low contaminant concentration that satisfies CDPH water quality requirements. Utilizing blending techniques lowers the operating costs of the facility and extends the life-cycle of the resins and treatment equipment by reducing the loading they experience. In addition, blending may lower the initial construction costs as fewer vessels for each treatment process are required.

Blending will occur at three locations. The first location is in the collection pipeline bringing raw water to the treatment plant. The second location is in parallel with the perchlorate treatment process. The third is in parallel with the nitrate treatment process.

**6.2 Blending Description**

The collection pipeline that brings raw water to the treatment plant receives well discharges at various locations along its length. The unique characteristics of each well’s discharge are lost as turbulent flow in the collection pipeline forces the concentration of contaminants to be uniformly dispersed. This uniformity of contaminant concentrations improves the effectiveness of the various treatment processes by reducing the possibility of momentarily exceeding the contaminant removal capacity with a surge of highly contaminated flow.

Raw water enters the plant and passes through the cartridge filter. Following the cartridge filter is the perchlorate treatment process. At this point, the water has a high concentration of perchlorate. Assuming the entire flow is treated, the resulting effluent would only have trace perchlorate remaining. However, instead of treating the entire flow, a portion of the flow will bypass the perchlorate treatment process. The bypassed flow, which has a high concentration of perchlorate, will be blended with the effluent from the perchlorate treatment process, which has trace perchlorate remaining. Once the bypass to treatment ratio has been refined, the resulting mixture will have a low concentration of perchlorate that satisfies CDPH water quality requirements. The ratio refinement process involves a mass balance calculation based on sampling from both the influent and effluent sides of the treatment process and an understanding of treatment process efficiency.

Following perchlorate blending, the flow passes through the GAC vessels for VOC removal. Typical blending will result in a VOC concentration below the MCL; permitting may allow the entire flow to bypass the GAC vessels under such circumstances. However, there are numerous well discharge combinations with a





**FEASIBILITY STUDY FOR THE MULTI-AGENCY REGIONAL GROUNDWATER RECOVERY PROJECT-100% DRAFT**

blended VOC concentration above the MCL which the treatment plant must be able to accommodate. The precise nature of VOC blending at this facility is under the discretion of the State.

Following VOC removal is the nitrate treatment process. As described above for perchlorate, a portion of the flow will be treated for nitrate and the remaining flow will bypass the nitrate treatment process. These portions will be based on a ratio determined by mass balance and sampling for nitrate. Finally, the bypassed flow and the flow treated for nitrate will be blended, and the resulting mixture will satisfy all water quality requirements for perchlorate, VOCs and nitrate.

Blending is a cost effective technique for maintaining precise compliance with CDPH MCL requirements. This cost-effectiveness is based on prolonging the potency and efficiency of the ion exchange media by limiting the amount of contaminants to be removed. The treatment plant will utilize blending procedures on both the perchlorate and nitrate treatment processes to maximize this cost savings.

**6.3 Blending Analysis Assumptions**

Perchlorate and nitrate are assumed to be blended, and VOC removal is assumed to be treated based on the worst case scenario.

To estimate the amount of water that will be bypassed around the perchlorate and nitrate treatment process, a mass-balance equation was solved based upon the total discharge from all the wells (15,000 gpm) and the following blended concentrations from Table 2-1:

- ◆ Perchlorate Concentration – 11.72 µg/L
- ◆ Nitrate Concentrations – 82.94 mg/L

To comply with CDPH, the blended concentration will need to be lowered to approximately 80% of the MCL; the MCL for perchlorate is 6 µg/L and the MCL for nitrate is 45 mg/L. To determine the amount of water that may be bypassed it will be assumed the treatment process will lower the concentrations of the contaminants to non-detect levels.



**FEASIBILITY STUDY FOR THE MULTI-AGENCY REGIONAL GROUNDWATER RECOVERY PROJECT-100% DRAFT**

The following equation determines the bypass for the perchlorate vessels:

$$C_{Required} = 0.8(MCL) = \frac{C_{Bypass} Q_{Bypass} + C_{Treat} Q_{Treat}}{Q_{Total}}$$

$$\Rightarrow Q_{Bypass} = \frac{0.8(MCL)Q_{Total} - C_{Treat} Q_{Treat}}{C_{Bypass}} = \frac{0.8(6 \mu\text{g} / \text{L})(15,000 \text{ gpm}) - 0}{11.72 \mu\text{g} / \text{L}} \cong 6,100 \text{ gpm}$$

Where *C* is concentration and *Q* is flow

It was determined that the amount of water that will bypass the perchlorate treatment process is approximately 6,100 gpm.

For the nitrate treatment process bypass, the same equation was used substituting a bypass concentration of 82.94 mg/L and an MCL of 45 mg/L. However, due to the high concentrations of nitrates in this system, ion leakage is expected to occur at an effluent concentration of between 3 and 10 mg/L. Therefore, the treated concentration will be adjusted to accommodate for ion leakage. Assuming a worst case scenario of 10 mg/L, the bypass flow rate is approximately 5,345 gpm:

$$C_{Required} = 0.8MCL = \frac{C_{Bypass} Q_{Bypass} + C_{Treat} (Q_{Total} - Q_{Bypass})}{Q_{Total}}$$

$$\Rightarrow Q_{Bypass} = \frac{Q_{Total} (0.8MCL - C_{Treat})}{C_{Bypass} - C_{Treat}} = \frac{15,000 \text{ gpm} (0.8 \times 45 \text{ mg} / \text{L} - 10 \text{ mg} / \text{L})}{82.94 \text{ mg} / \text{L} - 10 \text{ mg} / \text{L}} \cong 5,345 \text{ gpm}$$

Where *C* is concentration and *Q* is flow

Figure 6-1 shows the flow scenario for the perchlorate blending analysis and Figure 6-2 shows the flow scenario for the nitrate blending analysis.

**Figure 6-1: Blending Diagram for Perchlorate**

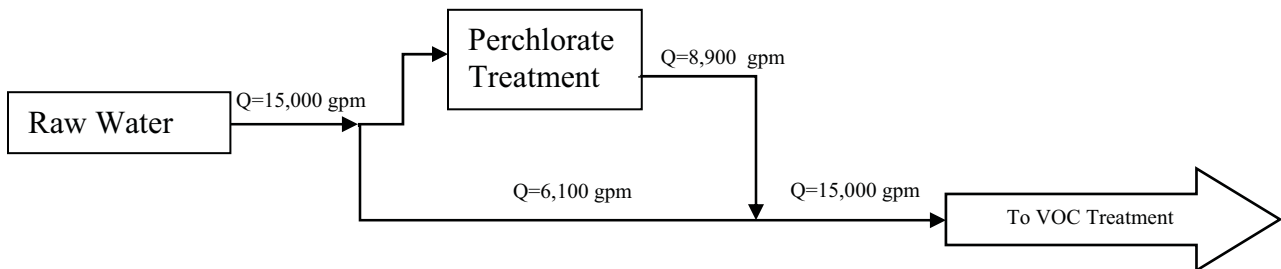

**FEASIBILITY STUDY FOR THE MULTI-AGENCY REGIONAL GROUNDWATER RECOVERY PROJECT-100% DRAFT**

**Figure 6-2: Blending Diagram for Nitrate**

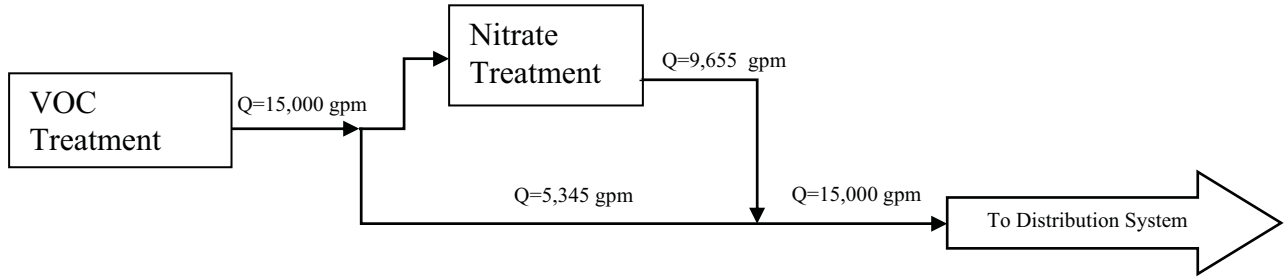

The worst case scenario of VOC concentration was found to be any combination of wells that includes the Aspan Well and results in a flow rate less than 9,500 gpm. Permitting may allow for blending; however, based on previous experience with similar projects, equipment must be installed to accommodate the worst case scenario regardless of the likelihood of such an eventuality.

The precise concentration of contaminants at any given point within the Main San Gabriel Basin is in flux. Due to the proximity of the contamination plume affecting the Baldwin Park Operable Unit to the well field examined in this study, concentrations of contaminants of interest are likely to fluctuate in response to unforeseen hydrological conditions. As a result, sufficient flexibility should be planned for the treatment plant site to allow for expansion of one or more of the treatment processes (i.e. space for additional Ion Exchange or GAC vessels) if contamination concentrations increase, or to allow for sufficient bypass of one or more of the treatment processes if contamination concentrations decrease.



**FEASIBILITY STUDY FOR THE MULTI-AGENCY REGIONAL GROUNDWATER RECOVERY  
PROJECT-100% DRAFT**

**Chapter 7 – Hydraulic Analysis**

**7.1 General**

This chapter provides a general overview of the relationship between supply and demand, the reliability and condition of groundwater sources, and the hydraulic components of the raw water collection system and the treated water distribution system. The methods and systems presented here represent a preliminary estimation of the basic requirements necessary to meet the project objectives and expectations.

**7.2 Demand**

Generally, the treatment facility is anticipated to be in continuous operation which means that production will not fluctuate to meet demands. Rather, peak demand for ALW and Glendora will be met first and the remaining production will be available for export to WVWD and RWD.

ALW and Glendora would benefit from the additional groundwater supply provided by the treatment facility by deflecting peak demand that would otherwise have to be met by increasing imported water deliveries. Imported water is more expensive and potentially less reliable than local groundwater. In addition, increasing local groundwater production will improve supply redundancy.

The remaining production will be exported to WVWD and RWD. The volume to be shared annually among ALW, Glendora, WVWD and RWD is approximately 24,200 AF. Following is an analysis of local demand conditions, a distribution calendar based on the findings of that analysis, and a brief summary of groundwater availability with respect to the participants.

**7.2.1: ALW Demand**

According to the City of Azusa 2005 Water Master Plan Update (ALW WMP), the projected average day demand (ADD) is 16,250 gpm, and the projected maximum day demand (MDD) is 24,375 gpm. The MDD represents the peak seasonal demand when ALW may be forced to rely on more expensive imported water if insufficient local groundwater and local surface water are available.

Currently, ALW relies on local groundwater, local surface water and imported water to meet its supply needs. Historical records show that approximately 80% of its production comes from local groundwater, 20% from local surface water, and less than 1% from its interconnection with the Metropolitan Water District (MWD). The MWD interconnection, designated as Turnout USG-8, provides treated surface water from the Weymouth Water Treatment Plant at a rate of 7.4 cubic feet per second (cfs) (3,300 gpm) and a head of 590 feet.







**FEASIBILITY STUDY FOR THE MULTI-AGENCY REGIONAL GROUNDWATER RECOVERY  
PROJECT-100% DRAFT**

To assure a reliable source of supply, ALW has recently expanded its local surface water production capacity by completing improvements to the Canyon Water Treatment Plant (Canyon WTP). As a result, the projected 2010 breakdown of supply is anticipated to be 12,762 acre-feet per year (AFY) (7,912 gpm) from local groundwater, 13,400 AFY (8,308 gpm) from local surface water and no imported water. Surface water production assumes a Canyon WTP capacity of 16 mgd (75% of rated plant capacity).

Under peak conditions (i.e. Maximum Day Demand), 16,067 gpm will have to be produced from groundwater sources to avoid reliance on imported water production:

$$\text{MDD} - \text{Canyon WTP} = 24,375 \text{ gpm} - 8,308 \text{ gpm} = 16,067 \text{ gpm}$$

Besides Well 9, Well 10 and the Aspan Well, all of ALW's remaining wells draw groundwater from the San Gabriel Canyon Basin, which is a sub-basin to the Main San Gabriel Groundwater Basin. This sub-basin is isolated by a fault system which impedes subsurface flow. As such, management of the sub-basin was assumed to include more recovery time to account for the sub-basin's limited capacity. For this reason, ALW's pumping capacity was set at 50% of the collective design flow for all wells extracting water from the sub-basin, which means 12 hours on and 12 hours off over a 24-hour period.

The current capacity of ALW's groundwater production, assuming the largest single groundwater source is out of service and each well is operated 50% of the time to allow for aquifer recovery, is approximately 9,300 gpm as shown in Table 7-1:



**FEASIBILITY STUDY FOR THE MULTI-AGENCY REGIONAL GROUNDWATER RECOVERY  
PROJECT-100% DRAFT**

**Table 7-1: Current Capacity of ALW’s Groundwater Production**

Source	Design Flow (gpm)	50% of Design Flow (gpm)
Well 1	2,500	1,250
Well 2	2,900	1,450
Well 3	3,500	1,750
Well 4	2,100	1,050
Well 5	1,100	550
Well 6	2,500	1,250
Well 7	1,200	600
Well 8	2,400	1,200
Well 9 <sup>1</sup>	0	0
Well 10 <sup>2</sup>	0	0
Well 11	2,300	1,150
Well 12	1,600	800
Aspan Well <sup>1</sup>	0	0
Capacity <sup>3</sup>	18,600	9,300

1 – Well 9 and Aspan Well are currently out of service due to contamination.

2 – Well 10, currently in limited use, was not considered in this analysis due to potential for contamination.

3 – Capacity is the sum of the Design Flows assuming that the largest single groundwater source is out of service as a safety precaution.

ALW has a deficit of approximately 6,800 gpm under peak conditions:

$$\text{Required GW} - \text{Available GW} = 16,067 - 9,300 = 6,767 \approx 6,800 \text{ gpm}$$

Figure 7-1 represents existing and build-out monthly demand fluctuation superimposed with ALW’s combined current redundant groundwater and surface water production capacity of 17,608 gpm.

FEASIBILITY STUDY FOR THE MULTI-AGENCY REGIONAL GROUNDWATER RECOVERY PROJECT-100% DRAFT

Figure 7-1: ALW’s Local Production Redundancy

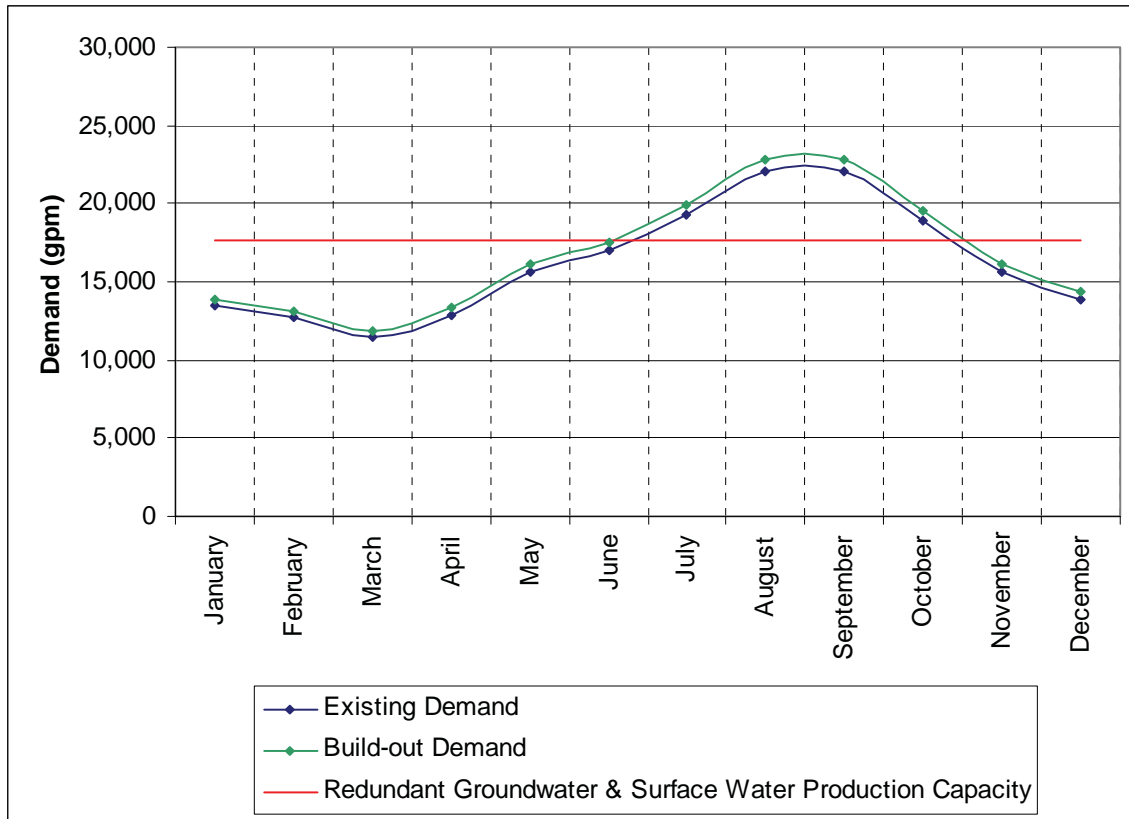

ALW demand appears to exceed its local production capacity from late June through October. Based on this analysis, ALW would benefit from an additional local groundwater source to avoid any reliance on imported water. It is recommended that ALW receive the equivalent of 1,700 gpm during July, 4,500 gpm during August, 4,500 gpm during September and 1,300 gpm during October each year (1,613 acre-feet).

**7.2.2: Glendora Demand**

According to the City of Glendora Water Master Plan (Glendora WMP), the projected ADD is 8,679 gpm, and the projected MDD is 16,056 gpm. The MDD represents the peak seasonal demand when Glendora may be forced to rely on more expensive imported water if insufficient local groundwater is available.

Currently, Glendora relies on local groundwater and imported water to meet its supply needs. Historical records show that approximately 84.6% of its production comes from local groundwater, 13.8% from water imported from MWD, and 1.6% from water imported from the Covina Irrigating Company. Glendora maintains three MWD interconnections, designated as Turnouts PM-18, PM-6 and PM-23, which provide